



- (51) International Patent Classification:  
E21B 34/12 (2006.01) E21B 34/00 (2006.01)
- (21) International Application Number:  
PCT/US2019/046445
- (22) International Filing Date:  
14 August 2019 (14.08.2019)
- (25) Filing Language: English
- (26) Publication Language: English
- (30) Priority Data:  
62/722,161 23 August 2018 (23.08.2018) US
- (71) Applicant: HALLIBURTON ENERGY SERVICES, INC. [US/US]; 3000 N. Sam Houston Parkway E., Houston, Texas 77032-3219 (US).
- (72) Inventors: VICK, JR., James Dan; 13545 Purple Sage Road, Dallas, Texas 75240 (US). SCOTT, Bruce Edward; 7220 Oakbury Lane, McKinney, Texas 75071 (US).

(74) Agent: PARKER JUSTISS, P.C. et al.; 14241 Dallas Parkway, Suite 620, Dallas, Texas 75254 (US).

(81) Designated States (unless otherwise indicated, for every kind of national protection available): AE, AG, AL, AM, AO, AT, AU, AZ, BA, BB, BG, BH, BN, BR, BW, BY, BZ, CA, CH, CL, CN, CO, CR, CU, CZ, DE, DJ, DK, DM, DO, DZ, EC, EE, EG, ES, FI, GB, GD, GE, GH, GM, GT, HN, HR, HU, ID, IL, IN, IR, IS, JO, JP, KE, KG, KH, KN, KP, KR, KW, KZ, LA, LC, LK, LR, LS, LU, LY, MA, MD, ME, MG, MK, MN, MW, MX, MY, MZ, NA, NG, NI, NO, NZ, OM, PA, PE, PG, PH, PL, PT, QA, RO, RS, RU, RW, SA, SC, SD, SE, SG, SK, SL, SM, ST, SV, SY, TH, TJ, TM, TN, TR, TT, TZ, UA, UG, US, UZ, VC, VN, ZA, ZM, ZW.

(84) Designated States (unless otherwise indicated, for every kind of regional protection available): ARIPO (BW, GH, GM, KE, LR, LS, MW, MZ, NA, RW, SD, SL, ST, SZ, TZ, UG, ZM, ZW), Eurasian (AM, AZ, BY, KG, KZ, RU, TJ, TM), European (AL, AT, BE, BG, CH, CY, CZ, DE, DK, EE, ES, FI, FR, GB, GR, HR, HU, IE, IS, IT, LT, LU, LV, MC, MK, MT, NL, NO, PL, PT, RO, RS, SE, SI, SK, SM,

(54) Title: INSERT SAFETY VALVE

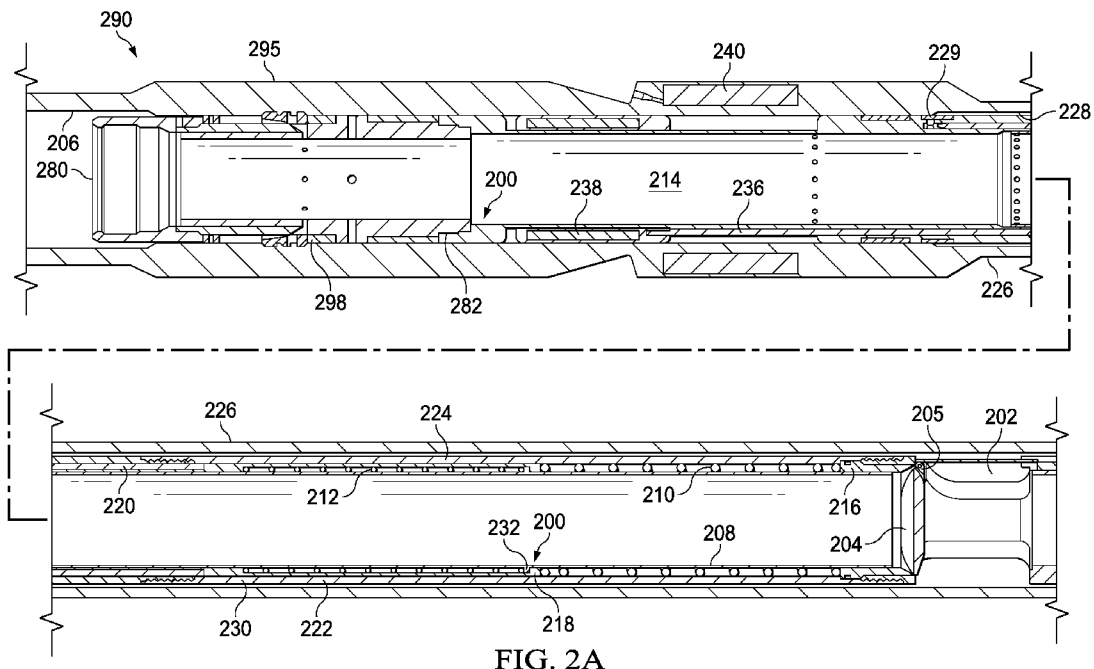

FIG. 2A

(57) Abstract: Provided is a safety valve. The safety valve, in one aspect, includes a valve body defining a central bore extending axially through the valve body, a sliding sleeve disposed in the central bore, and a flow tube disposed relative to the sliding sleeve. The safety valve, in this aspect, further includes a piston operable to transmit force to one or the other of the sliding sleeve or flow tube, a valve closure mechanism disposed on a distal end of the valve body, and an activation channel coupling the piston and a pressure downhole of the valve closure mechanism for providing the force to the one or the other of the sliding sleeve or flow tube.



WO 2020/041056 A1

TR), OAPI (BF, BJ, CF, CG, CI, CM, GA, GN, GQ, GW,  
KM, ML, MR, NE, SN, TD, TG).

**Published:**

— *with international search report (Art. 21(3))*

## INSERT SAFETY VALVE

### CROSS-REFERENCE TO RELATED APPLICATION

[0001] This application claims the benefit of U.S. Provisional Application Serial No. 62/722,161, filed on August 23, 2018, entitled “ELECTRIC INSERT SAFETY VALVE,” commonly assigned with this application and incorporated herein by reference in its entirety.

### BACKGROUND

[0002] Operations performed and equipment utilized in conjunction with a subterranean production well usually require a safety valve be set relatively deep in the production well to circumvent potential production mishaps that can occur with the producing well. For example, a safety valve may be set at a depth of 1,000 feet or more.

[0003] Most offshore hydrocarbon producing wells are required by law to include a surface-controlled subsurface safety valve (SCSSV) located downhole in the production string to shut off the flow of hydrocarbons in an emergency. These SCSSVs are usually set below the mudline in offshore wells. Often it is desired to have an insert safety valve (e.g., wireline retrievable safety valve) used in conjunction with the SCSSVs. What is needed in the art is an improved safety valve, and in one embodiment an improved insert safety valve, that does not encounter the problems of existing insert safety valves, as well as their use with existing SCSSVs.

### BRIEF DESCRIPTION

[0004] Reference is now made to the following descriptions taken in conjunction with the accompanying drawings, in which:

[0005] FIG. 1 illustrates a well system including an exemplary operating environment that the apparatuses, systems and methods disclosed herein may be employed;

[0006] FIGs. 2A-2C illustrate one embodiment of an safety valve manufactured according to the disclosure at a plurality of different operational positions;

[0007] FIGs. 3A-3B illustrate an alternative embodiment of a safety valve manufactured according to the disclosure at a plurality of different operational positions; and

[0008] FIGs. 4A-4B illustrate an alternative embodiment of a safety valve manufactured according to the disclosure at a plurality of different operational positions.

#### **DETAILED DESCRIPTION**

[0009] In the drawings and descriptions that follow, like parts are typically marked throughout the specification and drawings with the same reference numerals, respectively. The drawn figures are not necessarily, but may be, to scale. Certain features of the disclosure may be shown exaggerated in scale or in somewhat schematic form and some details of certain elements may not be shown in the interest of clarity and conciseness.

[0010] The present disclosure may be implemented in embodiments of different forms. Specific embodiments are described in detail and are shown in the drawings, with the understanding that the present disclosure is to be considered an exemplification of the principles of the disclosure, and is not intended to limit the disclosure to that illustrated and described herein. It is to be fully recognized that the different teachings of the embodiments discussed herein may be employed separately or in any suitable combination to produce desired results. Moreover, all statements herein reciting principles and aspects of the disclosure, as well as specific examples thereof, are intended to encompass equivalents thereof. Additionally, the term, "or," as used herein, refers to a non-exclusive or, unless otherwise indicated.

[0011] Unless otherwise specified, use of the terms “connect,” “engage,” “couple,” “attach,” or any other like term describing an interaction between elements is not meant to limit the interaction to direct interaction between the elements and may also include indirect interaction between the elements described.

[0012] Unless otherwise specified, use of the terms “up,” “upper,” “upward,” “uphole,” “upstream,” or other like terms shall be construed as generally toward the surface of the well; likewise, use of the terms “down,” “lower,” “downward,” “downhole,” or other like terms shall be construed as generally toward the bottom, terminal end of a well, regardless of the wellbore orientation. Use of any one or more of the foregoing terms shall not be construed as denoting positions along a perfectly vertical or horizontal axis. Unless otherwise specified, use of the term “subterranean formation” shall be construed as encompassing both areas below exposed earth and areas below earth covered by water, such as ocean or fresh water.

[0013] Referring to FIG. 1, depicted is a perspective view of a well system 100 including an exemplary operating environment that the apparatuses, systems and methods disclosed herein may be employed. The well system 100 includes an offshore platform 110 connected to a safety valve 120 (e.g., safety valve, insert safety valve, wireline retrievable safety valve, or a combination of such) via electrical connection 130. An annulus 140 may be defined between the wellbore 150 and a conduit 160 (e.g., production tubing). Wellhead 170 may provide a means to hand off and seal conduit 160 against wellbore 150 and provide a profile to latch a subsea blowout preventer to. Conduit 160 may be coupled to wellhead 170. Conduit 160 may be any conduit such as a casing, liner, production tubing, or other tubulars disposed in a wellbore.

[0014] Although well system 100 is depicted in FIG. 1 as an offshore well, one of ordinary skill should be able to adopt the teachings herein to any type of well system including

onshore or offshore. Electrical connection 130 may extend into the wellbore 150 and may be connected to the safety valve 120. Electrical connection 130 may provide power to an electromagnet disposed within the safety valve 120. As will be described in further detail below, power provided to the electromagnet may energize the electromagnet to hold components of the safety valve 120 in place.

**[0015]** Referring to FIG. 2A, an example of a safety valve 200 is illustrated in a first closed position. In the particular embodiment of FIG. 2A, the safety valve 200 is coupled to a lock mandrel 280, and is positioned within a production string 290. For example, threads 282 may couple the safety valve to the lock mandrel 280. The production string 290, in one embodiment, may form a portion of a SCSSV, among other possible downhole features (e.g., electric or otherwise). In the embodiment of FIG. 2A, the production string 290 includes a landing sub 295 (e.g., landing nipple). In the first closed position, the sliding sleeve 222 and flow tube 208 of the safety valve 200 are positioned such that sliding sleeve shoulder 218 and flow tube shoulder 232 are in contact, and power spring 210 and nose spring 212 are fully extended. In the first closed position, sliding sleeve 222 may be referred to as being in a first position and flow tube 208 may be referred to as being in a first position.

**[0016]** Components of safety valve 200 may be disposed within valve body 224. Safety valve 200 may be disposed in a wellbore as part of a wellbore completion string. The wellbore may penetrate an oil and gas bearing subterranean formation such that oil and gas within the subterranean formation may be produced. Lower section 202 may be directly exposed to formation fluids and pressure by being in fluid communication with fluids present in the wellbore. In accordance with one embodiment, the actuated safety valve 200 might be run down

after the fact within a tubular of the SCSSV, much the same way a service tool might be run (e.g., wireline deployed).

**[0017]** A valve closure mechanism 204 may isolate the lower section 202 from flow tube 208, which may prevent formation fluids and pressure from flowing into flow tube 208 when valve closure mechanism 204 is in a closed position. Valve closure mechanism 204 may be any type of valve such as a flapper type valve or a ball type valve. FIG. 2A illustrates the valve closure mechanism 204 as being a flapper type valve. As will be illustrated in further detail below, valve closure mechanism 204 may be actuated into an open position to allow formation fluids to flow from lower section 202 through a flow path 214, defined by lower section 202, an interior of a flow tube 208 and an interior of conduit 206 (e.g., in this embodiment formed as part of the production string 290).

**[0018]** When the safety valve 200 is in the first closed position, no amount of differential pressure across valve closure mechanism 204 will allow wellbore fluids to flow from lower section 202 into flow path 214. In the instance that pressure is increased in conduit 206 above the pressure in lower section 202, the valve closure mechanism 204 may open when the pressure in conduit 206 is high enough to overcome a spring force from flapper spring 205. The orientation of valve closure mechanism 204 may allow well treatment fluids to be pumped from a surface, such as a wellhead, into lower section 202 and into the subterranean formation. Once pressure in conduit 206 decreases, flapper spring 205 may cause valve closure mechanism 204 to return to the closed position and flow from lower section 202 into flow path 214 may be prevented. Should a pressure differential across valve closure mechanism 204 be reversed such that pressure in lower section 202 is greater than a pressure in conduit 206, valve closure mechanism 204 may

remain in a closed position and not allow fluids in the lower section 202 to flow into conduit 206.

**[0019]** The power spring 210 may be disposed between valve assembly 216 and sliding sleeve shoulder 218. As illustrated in FIG. 2A, sliding sleeve shoulder 218 and flow tube shoulder 232 may be in contact when safety valve 200 is in the first closed position. Power spring 210 may provide a positive spring force against sliding sleeve shoulder 218 which may keep flow tube 208 in the first position. Power spring 210 may also provide a positive spring force to return flow tube 208 and sliding sleeve 222 to the first position from a second position as will be explained below.

**[0020]** A nose spring 212 may be disposed between sliding sleeve assembly 230 and flow tube shoulder 232. Sliding sleeve 222 and sliding sleeve assembly 230 may be fixedly attached to allow sliding sleeve 222 to move when a force is applied to sliding sleeve assembly 230 from nose spring 212 or from piston 220. Nose spring 212 may provide a positive spring force against sliding sleeve assembly 230 and flow tube shoulder 232 which may move flow tube 208 from a first position to a second position. Nose spring 212 may also provide a positive spring force, which may move sliding sleeve 222 from the second position to the first position. The above described components may be disposed within tubing 226 which may be fixedly attached to valve assembly 216.

**[0021]** With reference to FIG. 2B, safety valve 200 is illustrated in a second closed position. In the second closed position, sliding sleeve 222 may be displaced from the first position to a second position relatively closer in proximity to valve closure mechanism 204. Flow tube 208 may translate downward until contacting valve closure mechanism.204. When the

safety valve 200 is in the second closed position, both power spring 210 and nose spring 212 may be in a compressed state.

**[0022]** To move sliding sleeve 222 to the second position, differential pressure across valve closure mechanism 204 may be increased by lowering pressure in conduit 206. Lowering pressure in conduit 206 may cause fluid from lower section 202 to flow through activation channel 228 defined between tubing 226 and valve body 224. There may be fluid communication between activation channel 228 and piston 220, for example using a filter 229. Activation channel 228 may allow fluid from lower section 202 to exert a pressure force on piston 220. Piston 220 may transfer the force through sliding sleeve assembly 230, which may further transfer the force into sliding sleeve shoulder 218. When the differential pressure across valve closure mechanism 204 is increased the pressure force exerted on piston 220 may be increased. When the differential pressure across valve closure mechanism 204 is increased beyond the spring force provided by nose spring 212 and power spring 210, nose spring 212 and power spring 210 may compress and allow sliding sleeve 222 to move into the second position and flow tube 208 to contact valve closure mechanism 204. In the instance that lower section 202 is a non-perforated section of pipe or where there is a plug in lower section 202 that prevents pressure being transmitted from lower section 202 to piston 220, a pressure differential across valve closure mechanism 204 may be induced through pipe swell.

**[0023]** In the second closed position, safety valve 200 remains safe as no fluids from lower section 202 can flow into flow tube 208. In the second closed position no amount of differential pressure across valve closure mechanism 204 should cause valve closure mechanism 204 to open to allow fluids from lower section 202 to flow into flow path 214. If pressure is increased in conduit 206, sliding sleeve 222 may move back to the first position illustrated in

FIG. 2A. Unlike conventional safety valves, which generally require a control line to supply pressure to actuate a piston to move a sliding sleeve, safety valve 200 in certain embodiments only requires pressure supplied by the wellbore fluids in lower section 202 to move the sliding sleeve 222.

[0024] With continued reference to FIG. 2B, connector rod 236 may be fixedly attached to sliding sleeve assembly 230 and magnetic assembly 238. The magnetic assembly 238 may comprise a variety of different magnets and remain within the purview of the disclosure. In one embodiment, however, the magnetic assembly 238 is a permanent magnet, and in yet a further embodiment, the magnetic assembly 238 comprises a permanent magnet comprising SmCo. In another embodiment, the magnetic assembly 238 comprises a ferromagnetic material. In yet another embodiment, the magnetic assembly 238 has no electrical parts. As illustrated, when sliding sleeve 222 is moved from the first position to the second position, connector rod 236 and magnetic assembly 238 may also be moved. At a time before, between, or after sliding sleeve 222 is allowed to come to the second position, an electromagnetic assembly 240 in the production string 290 may be powered on. Powering electromagnetic assembly 240 may cause the magnetic assembly 238 or another magnetic part of safety valve 200 to become fixed in place with the electromagnetic assembly 240. The magnetic assembly 238 may be attached to sliding sleeve assembly 230 through connector rod 236, thus when magnetic assembly 238 is fixed in place, sliding sleeve assembly 230 and sliding sleeve 222 may also become fixed in place. Powering electromagnetic assembly 240 may cause sliding sleeve 222 to become fixed in the second position. Electromagnets may provide a means to hold sliding sleeve 222 at any well depth. Hydraulic systems used in previous wellbore safety valves require control and balance

lines to actuate and hold a valve open. Hydraulic systems may have limitations on operational depth whereas electromagnets may not face the same challenges.

**[0025]** In the embodiment illustrated in FIG. 2B, the electromagnetic assembly 240 may form a portion of the production string 290, or alternatively form a portion of a SCSSV. For example, in the embodiment of FIGs. 2A through 2C, the electromagnetic assembly 240 is located in the landing sub 295. According to this embodiment, the electromagnetic assembly 240 is permanent, and thus fixed in place. Moreover, in one embodiment, the electromagnetic assembly 240 does not include any moving parts. Accordingly, it is the magnetic assembly 238 that forms a portion of the safety valve 200 that moves. In such an example where the electromagnetic assembly 240 forms a portion of a SCSSV, the safety valve 200 might act as a secondary or backup safety valve. In such a configuration, the safety valve 200 might be lowered downhole using wireline, coil tubing, or another semi-permanent method. In the embodiment shown, the safety valve 200, and more specially the lock mandrel 280, seats within a profile 298 in the landing sub 295.

**[0026]** While an electromagnetic assembly 240, and related magnetic assembly 238 have been illustrated and described with respect to FIG. 2B, other embodiments may exist wherein another type of electric assembly could be used. For example, in another embodiment, an electric solenoid and a pin could be used to electrically fix the features of the safety valve 200 to the features of the production string 290. Accordingly, the present disclosure should not be limited to any specific type of coupling mechanism.

**[0027]** With reference to FIG. 2C, safety valve 200 is illustrated in an open position. When safety valve 200 is in the open position, sliding sleeve 222 may be fixed in place in the second position as in FIG. 2B through the force provided by electromagnetic assembly 240 and

magnetic assembly 238, the force being transferred through connector rod 236 to sliding sleeve assembly 230. Flow tube 208 is illustrated as being axially shifted from the first position illustrated in FIGs. 2A and 2B to a second position in FIG. 2C. When flow tube 208 is in the second position, flow tube shoulder 232 and sliding sleeve shoulder 218 may be in contact and flow tube 208 may have displaced valve closure mechanism 204 into an open position. Nose spring 212 may be in an uncompressed state while power spring 210 may be in a compressed state.

**[0028]** Flow tube 208 may be moved from the first position to the second position when sliding sleeve 222 is fixed in place in the second position. When sliding sleeve 222 is fixed in the second position, nose spring 212 may provide a positive spring force against flow tube shoulder 232 and sliding sleeve assembly 230. The positive spring force from nose spring 212 may be transferred through flow tube 208 into valve closure mechanism 204. In the instance where the positive spring force from nose spring 212 is greater than the differential pressure across valve closure mechanism 204, nose spring 212 may extend and move flow tube 208 into the second position. Alternatively, if the positive spring force from nose spring 212 is not greater than the differential pressure across valve closure mechanism 204, pressure in conduit 206 may be increased until the pressure in conduit 206 and positive spring force from nose spring 212 overcome the differential pressure across valve closure mechanism 204. The positive spring force from nose spring 212 may then move flow tube 208 into the second position. When flow tube 208 is in the second position, fluids such as oil and gas in lower section 202 may be able to flow into flow path 214 and to a surface of the well bore such as to a wellhead. Safety valve 200 may remain in the open position with sliding sleeve 222 in the second position and flow tube 208 in the second position as long as electromagnetic assembly 240 remains powered on.

[0029] Safety valve 200 may be moved to the first closed position as illustrated in FIG. 2A by powering off electromagnetic assembly 240. As previously discussed, electromagnetic assembly 240 and magnetic assembly 238 may fix sliding sleeve assembly 230 in place in the second position when the electromagnetic assembly 240 remains powered on. When electromagnetic assembly 240 is powered off, sliding sleeve assembly 230 may no longer be fixed in place. Power spring 210 may provide a positive spring force against valve assembly 216, sliding sleeve shoulder 218, and flow tube shoulder 232 through contact between sliding sleeve shoulder 218 and flow tube shoulder 232. Positive spring force from power spring 210 may axially displace sliding sleeve 222 to the first position and flow tube 208 to the first position, thereby returning safety valve 200 to the first closed position illustrated in FIG. 2A. Positive spring force from power spring 210 may axially displace magnetic assembly 238 to the position illustrated in FIG. 2A by transmitting the positive spring force through connector rod 236.

[0030] Turning briefly to FIGs. 3A and 3B, illustrated is an alternative embodiment of an safety valve 300 placed within a production string 390 according to the disclosure. The safety valve 300 is similar in many respects to the safety valve 200 of FIGs. 2A through 2C. Accordingly, like reference numerals may be used to indicate similar, if not identical, features. The view of FIG. 3A may be similar to the view of FIG. 2A, whereas the view of FIG. 3B may be similar to the view of FIG. 2B.

[0031] The embodiment shown in FIGs. 2A through 2C implies an electromagnetic assembly 240 with a dedicated electric control line from the surface; e.g. from the wellhead (WH)/Christmas tree (XT). It is further implied that additional electric downhole features, such as an electric SCSSV (e.g., if used) have their own dedicated electric control lines, e.g. one or more, but typically two, that do not interact with the dedicated electric control line coupled to the

electromagnetic assembly 240. This implies three (e.g., or more) electric control lines extending down from the WH/XT to the electromagnetic assembly 240 and the additional downhole electric features, along with their respective hardware and tubing hanger penetrations.

**[0032]** In order to reduce the number of electric control lines, tubing hanger penetrations, etc., one or more of the electric safety valve control lines can be used to provide power to the electromagnetic assembly 240 and the additional downhole electric features. This can be accomplished by including a control module 310 adjacent the electromagnetic assembly 240, either uphole or downhole of the electromagnetic assembly 240. In this configuration, a first electric control line 320 would enter the control module 310 from uphole, and then a second electric control line 330 would then exit the control module 310 and extend downhole to the additional electric downhole features, such as the electric SCSSV. In this embodiment, the control module 310 routes power to the electromagnetic assembly 240 and/or the additional downhole electric features. The control module 310 also provides a means of disconnecting the electricity to the additional downhole electric features in the event of a failure of the additional downhole electric features. For example, if the additional downhole electric feature were an electric SCSSV, if the electric SCSSV were to fail the control module 310 could be used to disconnect power thereto, such that if necessary all the power could be focused with the electromagnetic assembly 240.

**[0033]** With reference to FIGs. 3A and 3B, the control module 310 is located uphole of the electromagnetic assembly 240, and thus the power first enters the control module 310. In this configuration, when the additional downhole electric feature is functioning normally electricity is directed to the additional downhole electric feature and not to the electromagnetic assembly 240. In the event the additional downhole electric feature fails, the control module 310 directs the

electricity to the electromagnetic assembly 240 and not to the additional downhole electric feature.

**[0034]** Turning briefly to FIGs. 4A and 4B, illustrated is an alternative embodiment of an safety valve 400 according to the disclosure. In this embodiment, the control module 410 is located downhole of the electromagnetic assembly 240, and thus the power first enters the electromagnetic assembly 240. In this configuration, a first electric control line 420 would enter the electromagnetic assembly 240, power would travel through the electromagnetic assembly 240 to the control module 410, and then a second electric control line 430 would then exit the control module 410 and extend downhole to the additional electric downhole features, such as the electric SCSSV. According to this embodiment, and for simplicity in the design, the system may be configured so that electricity always flows through the electromagnetic assembly 240.

**[0035]** A process control system may be utilized to monitor and control production of formation fluids from a well where the safety valve is disposed. A process control system may comprise components such as flowmeters, pressure transducers, pumps, power systems, and associated controls system for each. The process control system may provide power to the safety valve to turn on and off the electromagnetic assembly therein. The electromagnetic assembly may be designed to run off any power source such as alternating current ("A/C") or direct current ("D/C"). The process control system may allow an operator to open the safety valve by the methods described above by using the pump to reduce pressure, powering the electromagnetic assembly, and using the pump to increase pressure. Wellbore fluid pressures and flow rates may be monitored by the process control system to ensure safe operating conditions and that the production process does not exceed safety limitations. Should a problem occur such as an overpressure event, the process control system may detect the problem and automatically cut

power to the safety valve. As discussed above, cutting power to the safety valve may cause the safety valve to automatically close thereby containing pressures and fluids.

[0036] Aspects disclosed herein include:

A. A safety valve, including: a valve body defining a central bore extending axially through the valve body; a sliding sleeve disposed in the central bore; a flow tube disposed relative to the sliding sleeve; a piston operable to transmit force to one or the other of the sliding sleeve or flow tube; a valve closure mechanism disposed on a distal end of the valve body; and an activation channel coupling the piston and a pressure downhole of the valve closure mechanism for providing the force to the one or the other of the sliding sleeve or flow tube.

B. A well system, including: a production string having a production string central bore located in a wellbore; a safety valve positioned within the production string central bore, the safety valve including 1) a valve body defining a central bore extending axially through the valve body, 2) a sliding sleeve disposed in the central bore, 3) a flow tube disposed relative to the sliding sleeve, 4) a piston operable to transmit force to one or the other of the sliding sleeve or flow tube, 5) a valve closure mechanism disposed on a distal end of the valve body, and 6) an activation channel coupling the piston and a pressure in the production string downhole of the valve closure mechanism for providing the force to the one or the other of the sliding sleeve or flow tube.

C. A method for operating a well system, including: positioning a production string having a production string central bore in a wellbore; positioning a safety valve within the production string central bore, the safety valve including 1) a valve body defining a central bore extending axially through the valve body, 2) a sliding sleeve disposed in the central bore, 3) a flow tube disposed relative to the sliding sleeve, 4) a piston operable to transmit force to one or

the other of the sliding sleeve or flow tube, 5) a valve closure mechanism disposed on a distal end of the valve body, and 6) an activation channel coupling the piston and a pressure in the production string downhole of the valve closure mechanism for providing the force to the one or the other of the sliding sleeve or flow tube; applying downhole pressure from the production string below the valve closure mechanism to the piston via the activation channel to move the piston and assist in opening the safety valve.

**[0037]** Aspects A, B, and C may have one or more of the following additional elements in combination: Element 1: wherein the activation channel couples the piston and the pressure downhole of the valve closure mechanism through the valve body. Element 2: wherein at least a portion of the activation channel comprises an annulus between the valve body and tubing disposed thereabout. Element 3: wherein the tubing is production tubing. Element 4: wherein the tubing is a portion of a surface-controlled subsurface safety valve. Element 5: further including a magnetic assembly movable with the sliding sleeve or flow tube, the magnetic assembly operable to couple to a fixed electromagnetic assembly in tubing disposed thereabout to prevent the sliding sleeve or flow tube from moving. Element 6: wherein the magnetic assembly comprises a ferromagnetic material. Element 7: wherein the valve body defines a portion of an insert safety valve, and further wherein no power is routed to the insert safety valve. Element 8: wherein the production string includes a surface-controlled subsurface safety valve, and further wherein the at least a portion of the activation channel comprises an annulus between the valve body and the surface-controlled subsurface safety valve. Element 9: wherein the production string has a fixed electromagnetic assembly coupled thereto, and further wherein the safety valve includes a magnetic assembly movable with the sliding sleeve or flow tube, the magnetic assembly operable to couple to the fixed electromagnetic assembly to prevent the

sliding sleeve or flow tube from moving. Element 10: wherein power is routed to the fixed electromagnetic assembly but no power is routed to the safety valve. Element 11: wherein the production string additionally includes a fixed electromagnetic assembly coupled thereto, and further wherein the safety valve includes a magnetic assembly movable with the sliding sleeve or flow tube, the magnetic assembly operable to couple to the fixed electromagnetic assembly to prevent the sliding sleeve or flow tube from moving uphole. Element 12: further including energizing the fixed electromagnetic assembly to fix the magnetic assembly to the fixed electromagnetic assembly to prevent the sliding sleeve or flow tube from moving uphole. Element 13: further including equalizing a pressure across the valve closure mechanism after energizing the fixed electromagnetic assembly, thereby allowing the flow tube to open and extend past the valve closure mechanism. Element 14: further including cutting power to the energized fixed electromagnetic assembly, thereby causing the flow tube to move uphole past the valve closure mechanism and close the safety valve.

**[0038]** Those skilled in the art to which this application relates will appreciate that other and further additions, deletions, substitutions and modifications may be made to the described embodiments.

**WHAT IS CLAIMED IS:**

1. A safety valve, comprising:  
a valve body defining a central bore extending axially through the valve body;  
a sliding sleeve disposed in the central bore;  
a flow tube disposed relative to the sliding sleeve;  
a piston operable to transmit force to one or the other of the sliding sleeve or flow tube;  
a valve closure mechanism disposed on a distal end of the valve body; and  
an activation channel coupling the piston and a pressure downhole of the valve closure mechanism for providing the force to the one or the other of the sliding sleeve or flow tube.
2. The safety valve as recited in Claim 1, wherein the activation channel couples the piston and the pressure downhole of the valve closure mechanism through the valve body.
3. The safety valve as recited in Claim 1, wherein at least a portion of the activation channel comprises an annulus between the valve body and tubing disposed thereabout.
4. The safety valve as recited in Claim 3, wherein the tubing is production tubing.
5. The safety valve as recited in Claim 3, wherein the tubing is a portion of a surface-controlled subsurface safety valve.
6. The safety valve as recited in Claim 1, further including a magnetic assembly movable with the sliding sleeve or flow tube, the magnetic assembly operable to couple to a

fixed electromagnetic assembly in tubing disposed thereabout to prevent the sliding sleeve or flow tube from moving.

7. The safety valve as recited in Claim 6, wherein the magnetic assembly comprises a ferromagnetic material.

8. The safety valve as recited in Claim 1, wherein the valve body defines a portion of an insert safety valve, and further wherein no power is routed to the insert safety valve.

9. A well system, comprising:  
a production string having a production string central bore located in a wellbore; and  
a safety valve positioned within the production string central bore, the safety valve including;

a valve body defining a central bore extending axially through the valve body;

a sliding sleeve disposed in the central bore;

a flow tube disposed relative to the sliding sleeve;

a piston operable to transmit force to one or the other of the sliding sleeve or flow tube;

a valve closure mechanism disposed on a distal end of the valve body; and

an activation channel coupling the piston and a pressure in the production string downhole of the valve closure mechanism for providing the force to the one or the other of the sliding sleeve or flow tube.

10. The well system as recited in Claim 9, wherein at least a portion of the activation channel comprises an annulus between the valve body and production string.

11. The well system as recited in Claim 10, wherein the production string includes a surface-controlled subsurface safety valve, and further wherein the at least a portion of the activation channel comprises an annulus between the valve body and the surface-controlled subsurface safety valve.

12. The well system as recited in Claim 11, wherein the production string has a fixed electromagnetic assembly coupled thereto, and further wherein the safety valve includes a magnetic assembly movable with the sliding sleeve or flow tube, the magnetic assembly operable to couple to the fixed electromagnetic assembly to prevent the sliding sleeve or flow tube from moving.

13. The well system as recited in Claim 12, wherein the magnetic assembly comprises a ferromagnetic material.

14. The well system as recited in Claim 9, wherein power is routed to the fixed electromagnetic assembly but no power is routed to the safety valve.

15. A method for operating a well system, comprising:  
positioning a production string having a production string central bore in a wellbore;  
positioning a safety valve within the production string central bore, the safety valve including:  
a valve body defining a central bore extending axially through the valve body;  
a sliding sleeve disposed in the central bore;  
a flow tube disposed relative to the sliding sleeve;  
a piston operable to transmit force to one or the other of the sliding sleeve or flow tube;  
a valve closure mechanism disposed on a distal end of the valve body; and  
an activation channel coupling the piston and a pressure in the production string downhole of the valve closure mechanism for providing the force to the one or the other of the sliding sleeve or flow tube;  
applying downhole pressure from the production string below the valve closure mechanism to the piston via the activation channel to move the piston and assist in opening the safety valve.

16. The method as recited in Claim 15, wherein the production string additionally includes a fixed electromagnetic assembly coupled thereto, and further wherein the safety valve includes a magnetic assembly movable with the sliding sleeve or flow tube, the magnetic assembly operable to couple to the fixed electromagnetic assembly to prevent the sliding sleeve or flow tube from moving uphole.

17. The method as recited in Claim 16, further including energizing the fixed electromagnetic assembly to fix the magnetic assembly to the fixed electromagnetic assembly to prevent the sliding sleeve or flow tube from moving uphole.

18. The method as recited in Claim 17, further including equalizing a pressure across the valve closure mechanism after energizing the fixed electromagnetic assembly, thereby allowing the flow tube to open and extend past the valve closure mechanism.

19. The method as recited in Claim 18, further including cutting power to the energized fixed electromagnetic assembly, thereby causing the flow tube to move uphole past the valve closure mechanism and close the safety valve.

20. The method as recited in Claim 15, wherein the safety valve is an insert safety valve that has no power routed thereto.

1/6

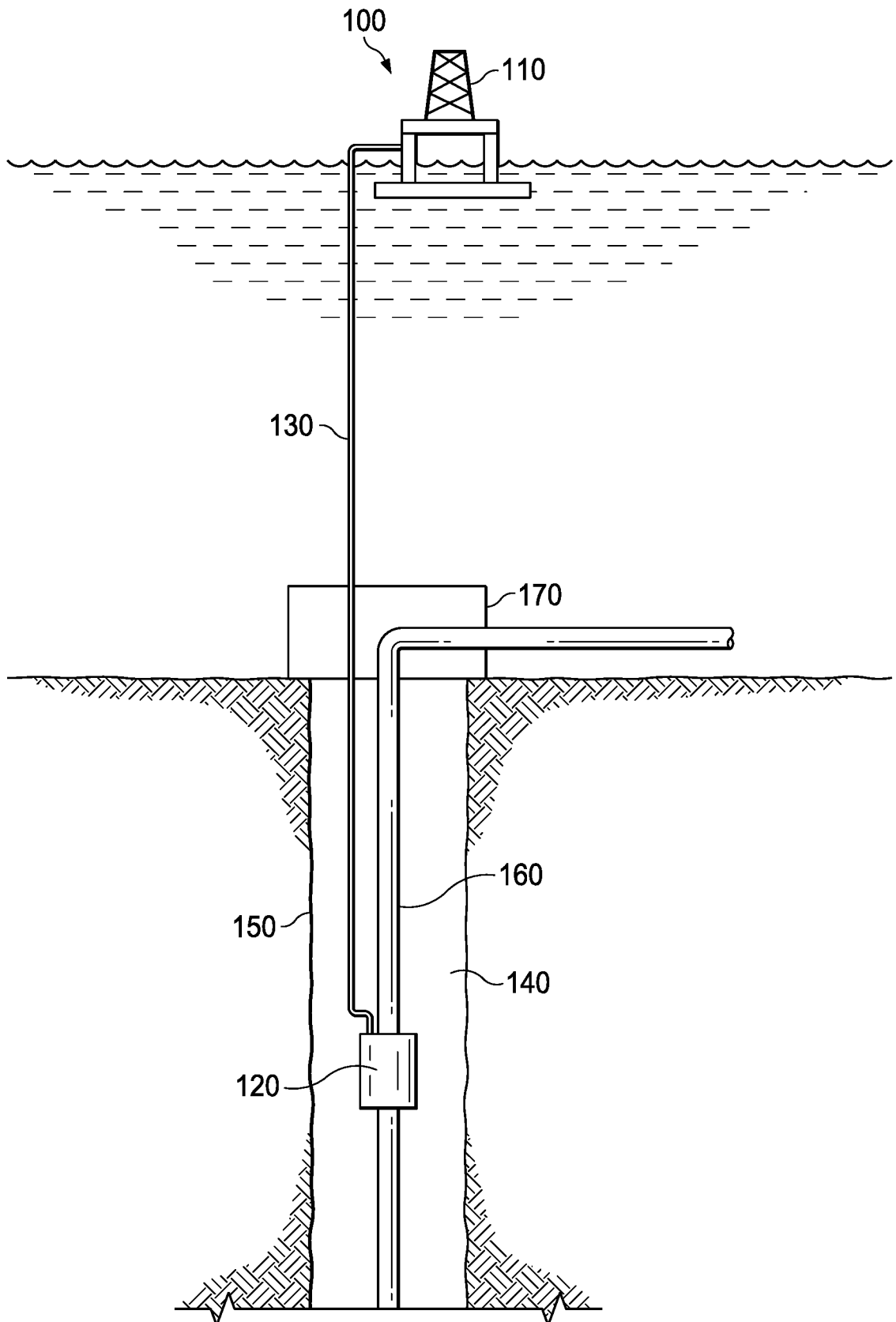

FIG. 1

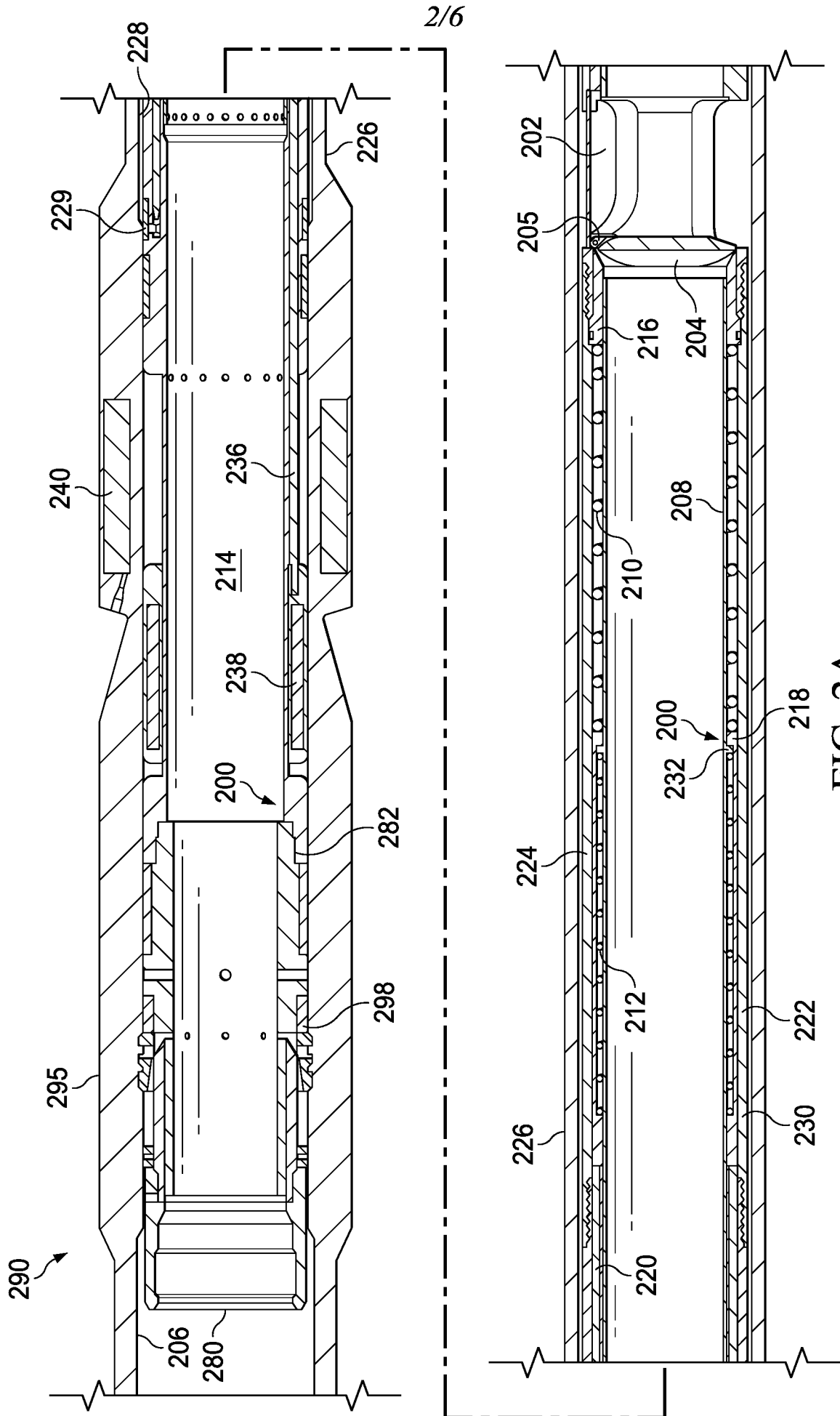
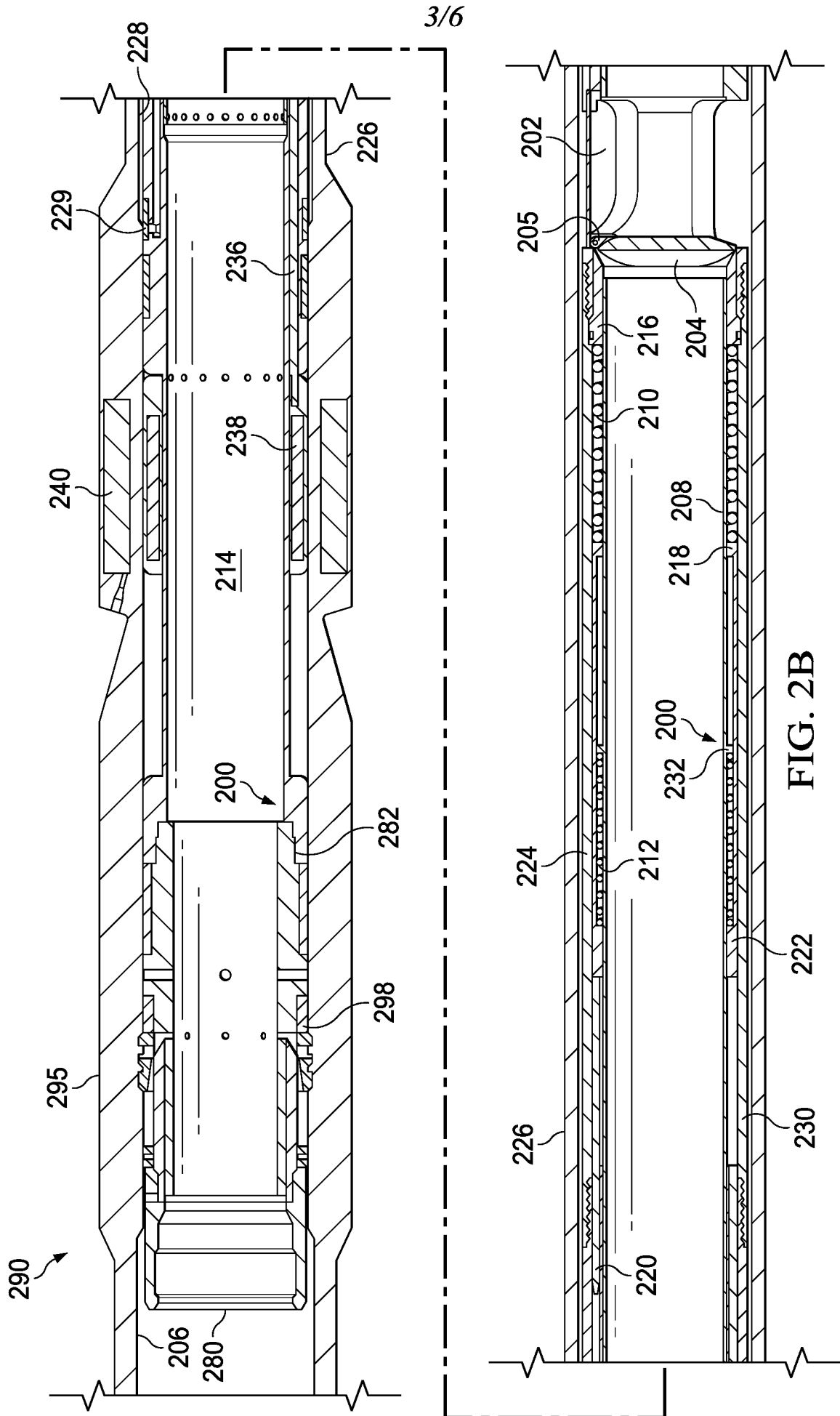

FIG. 2A



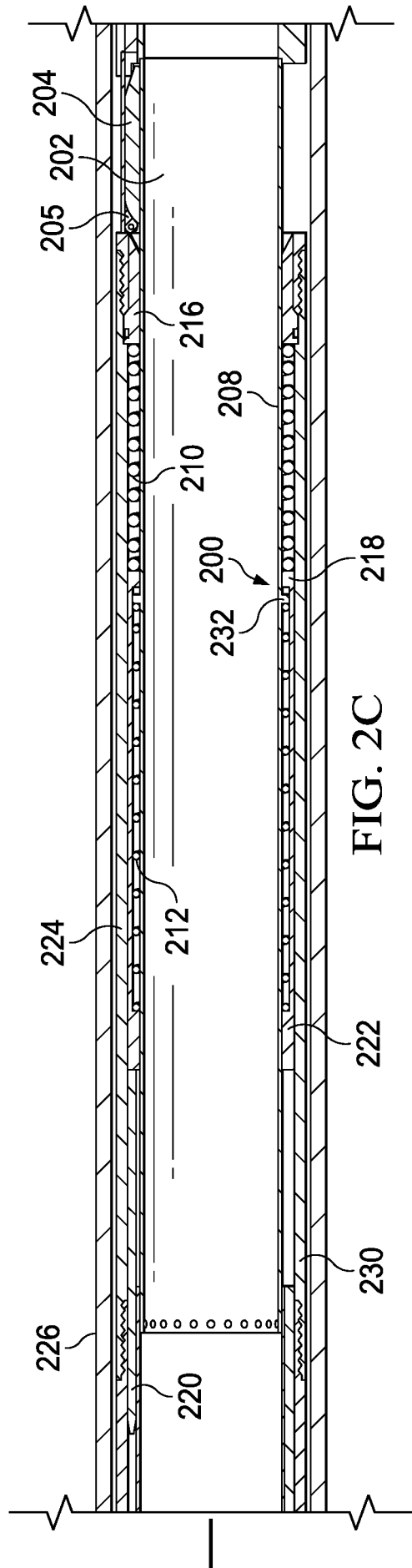
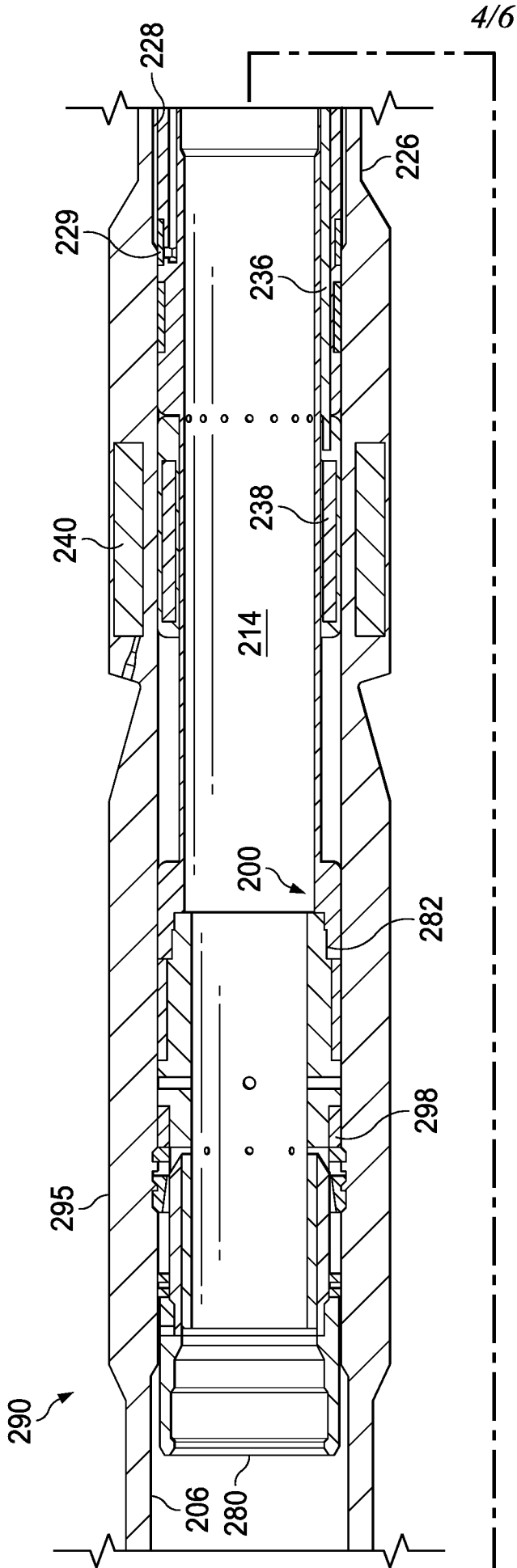
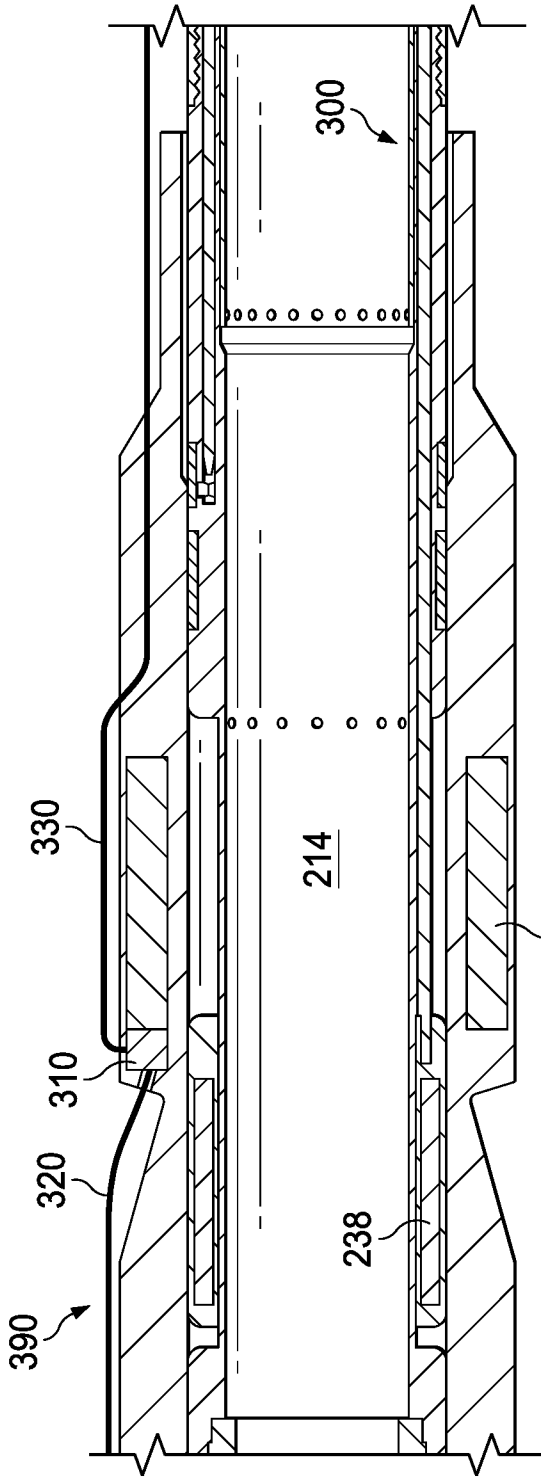
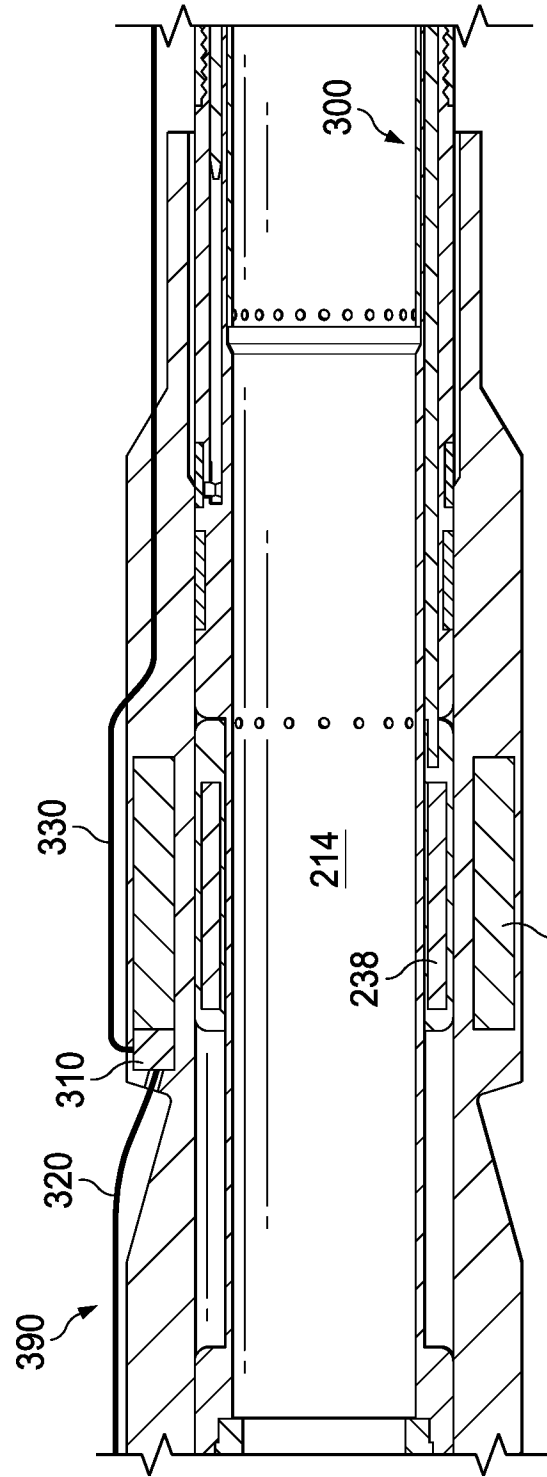

FIG. 2C



240 FIG. 3A



240 FIG. 3B

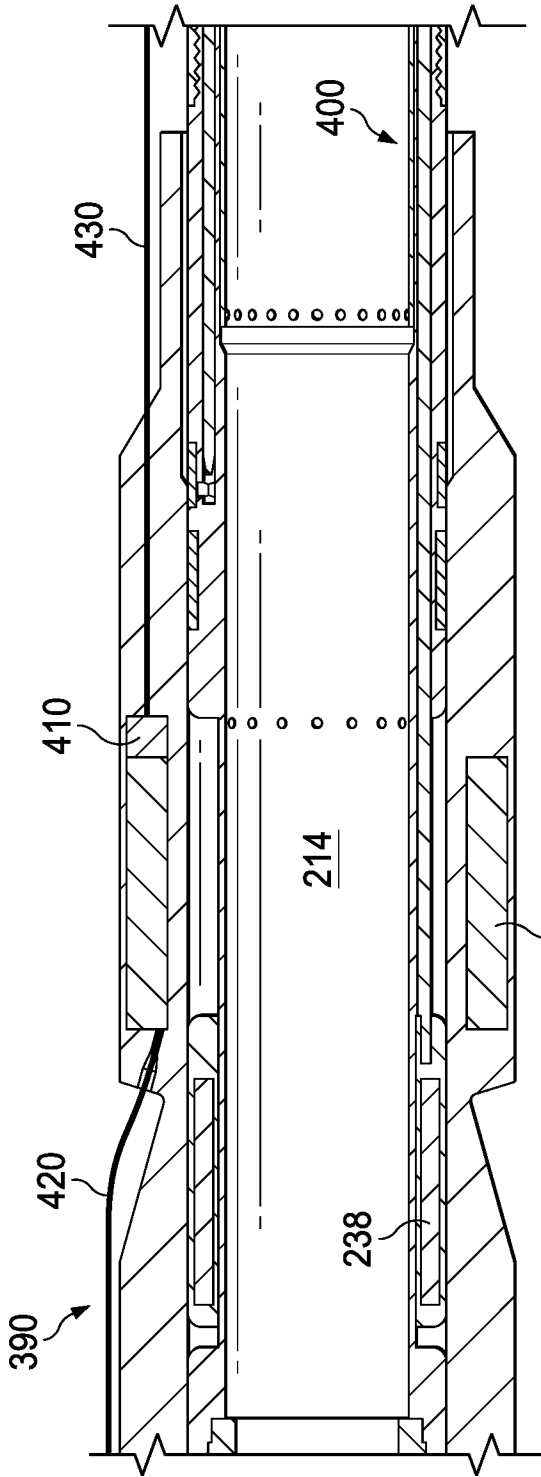

240 FIG. 4A

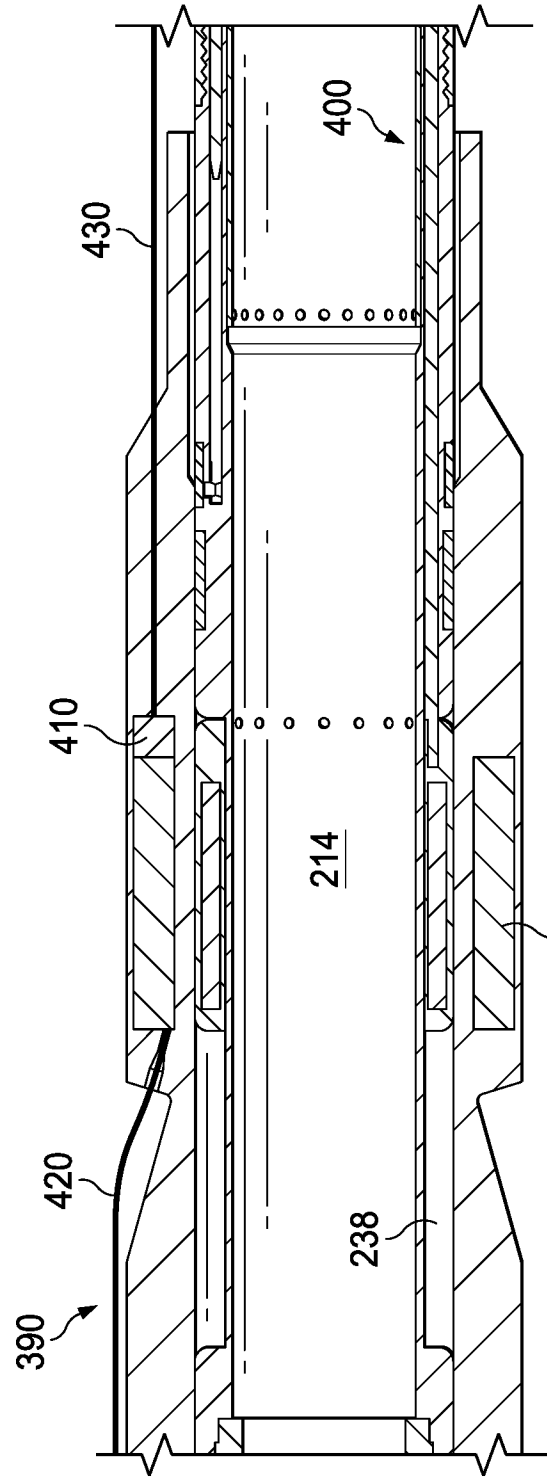

240 FIG. 4B

## INTERNATIONAL SEARCH REPORT

International application No.  
**PCT/US2019/046445****A. CLASSIFICATION OF SUBJECT MATTER****E21B 34/12(2006.01)i, E21B 34/00(2006.01)i**

According to International Patent Classification (IPC) or to both national classification and IPC

**B. FIELDS SEARCHED**Minimum documentation searched (classification system followed by classification symbols)  
E21B 34/12; E21B 23/03; E21B 34/00; E21B 34/10; E21B 34/14; F16K 31/16Documentation searched other than minimum documentation to the extent that such documents are included in the fields searched  
Korean utility models and applications for utility models  
Japanese utility models and applications for utility modelsElectronic data base consulted during the international search (name of data base and, where practicable, search terms used)  
eKOMPASS(KIPO internal) & keywords: safety valve, valve body, sliding sleeve, flow tube, piston, valve closure mechanism, activation channel**C. DOCUMENTS CONSIDERED TO BE RELEVANT**

Category*	Citation of document, with indication, where appropriate, of the relevant passages	Relevant to claim No.
X	US 3865141 A (YOUNG, DAVID E.) 11 February 1975 See column 3, line 6 - column 6, line 9 and figures 1-4.	1-5, 8-11, 15, 20
Y		6-7, 12-14, 16-19
Y	US 2011-0155381 A1 (REAUX, JAMES) 30 June 2011 See paragraph [0025], claims 1-4, 6, 20, and figure 6.	6-7, 12-14, 16-19
X	US 4325431 A (AKKERMAN, NEIL H.) 20 April 1982 See column 5, lines 57-68 and figures 1A-1B.	1
A	US 2015-0167423 A1 (KUCERA, SAMUEL C.) 18 June 2015 See paragraph [0013] and figures 1-3.	1-20
A	US 2016-0138365 A1 (HALLIBURTON ENERGY SERVICES, INC.) 19 May 2016 See figure 1A.	1-20

 Further documents are listed in the continuation of Box C. See patent family annex.

\* Special categories of cited documents:

"A" document defining the general state of the art which is not considered to be of particular relevance

"D" document cited by the applicant in the international application

"E" earlier application or patent but published on or after the international filing date

"L" document which may throw doubts on priority claim(s) or which is cited to establish the publication date of another citation or other special reason (as specified)

"O" document referring to an oral disclosure, use, exhibition or other means

"P" document published prior to the international filing date but later than the priority date claimed

"T" later document published after the international filing date or priority date and not in conflict with the application but cited to understand the principle or theory underlying the invention

"X" document of particular relevance; the claimed invention cannot be considered novel or cannot be considered to involve an inventive step when the document is taken alone

"Y" document of particular relevance; the claimed invention cannot be considered to involve an inventive step when the document is combined with one or more other such documents, such combination being obvious to a person skilled in the art

"&amp;" document member of the same patent family

Date of the actual completion of the international search

02 December 2019 (02.12.2019)

Date of mailing of the international search report

**02 December 2019 (02.12.2019)**

Name and mailing address of the ISA/KR

International Application Division

Korean Intellectual Property Office

189 Cheongsa-ro, Seo-gu, Daejeon, 35208, Republic of Korea

Facsimile No. +82-42-481-8578

Authorized officer

LEE, Hun Gil

Telephone No. +82-42-481-8525



**INTERNATIONAL SEARCH REPORT**

Information on patent family members

International application No.

**PCT/US2019/046445**

Patent document cited in search report	Publication date	Patent family member(s)	Publication date
US 3865141 A	11/02/1975	None	
US 2011-0155381 A1	30/06/2011	US 8353353 B2 WO 2011-005826 A1	15/01/2013 13/01/2011
US 4325431 A	20/04/1982	CA 1156927 A	15/11/1983
US 2015-0167423 A1	18/06/2015	US 9470064 B2 WO 2015-094520 A1	18/10/2016 25/06/2015
US 2016-0138365 A1	19/05/2016	BR 112015025866 A2 GB 2527445 A NO 20151301 A US 10113392 B2 WO 2014-189494 A1	25/07/2017 23/12/2015 02/10/2015 30/10/2018 27/11/2014