

No. 679,436.

Patented July 30, 1901.

E. J. SONN.
ATOMIZER.

(Application filed June 13, 1900.)

(No Model.)

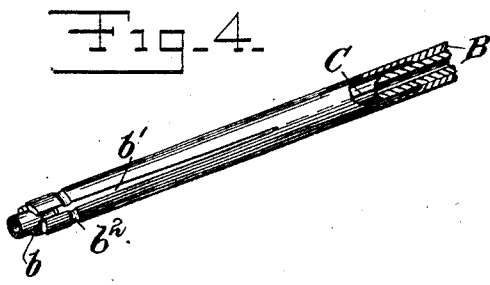
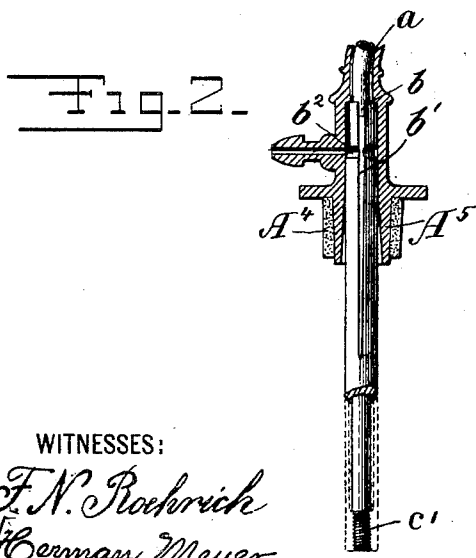
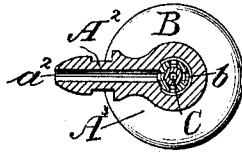
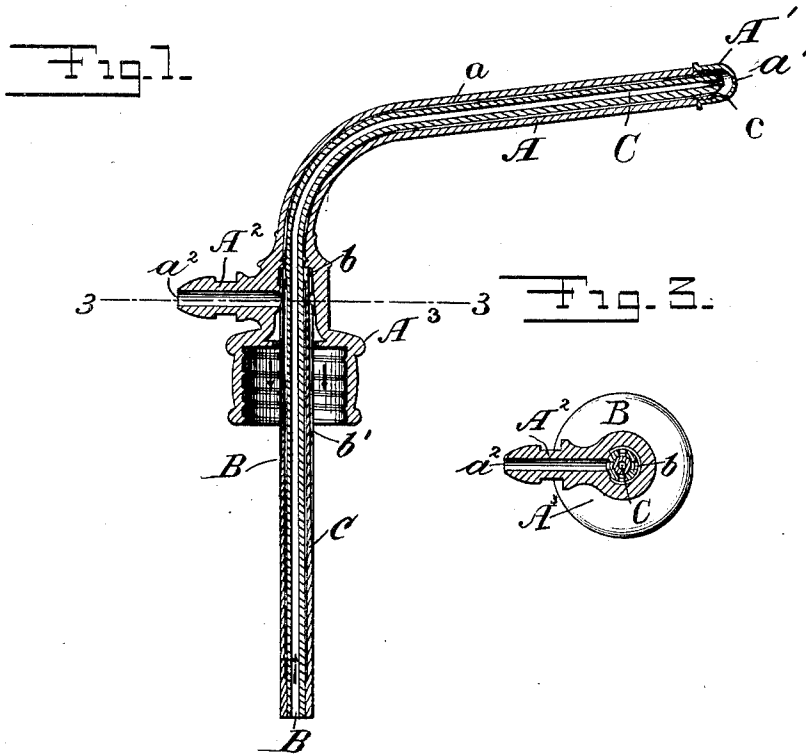

WITNESSES:
F. N. Rockovich
Herman Meyer

INVENTOR
Emanuel J. Sonn
BY
Stephen J. Cox
ATTORNEY

UNITED STATES PATENT OFFICE.

EMANUEL J. SONN, OF NEW YORK, N. Y.

ATOMIZER.

SPECIFICATION forming part of Letters Patent No. 679,436, dated July 30, 1901.

Application filed June 13, 1900. Serial No. 20,161. (No model.)

To all whom it may concern:

Be it known that I, EMANUEL J. SONN, a citizen of the United States, residing in the city, county, and State of New York, have invented certain new and useful Improvements in Atomizers, of which the following is a specification.

My invention relates to atomizers or sprayers which are adapted to be used for medicinal or other purposes, and particularly to that class of atomizers wherein it is essential that the head and tubing be made of hard rubber or other like brittle material; and its objects are, among others, to add strength and durability to the said parts and to render them more serviceable and effective and less liable to breakage.

To these ends it consists of the combination of parts and arrangement of details herein-after described and claimed, and illustrated in the accompanying drawings referred to herein, like letters referring to like parts in each figure thereof.

In the said drawings, Figure 1 is a vertical section of the head and tubing of an atomizer, showing my improvements. Fig. 2 is a like view of a modification. Fig. 3 is a horizontal section on the line 3 3 of Fig. 1. Fig. 4 is a detail of the tubes B and C of Fig. 1.

The head A^3 is of sufficient diameter to pass over the neck of the bottle or other vessel containing the liquid-supply and may be interiorly threaded to correspond with a thread on the exterior of said neck. It may, however, be of the form shown in Fig. 2, adapted to fit into the inside of the bottle-neck and provided with an exterior sleeve A^4 , of rubber or other elastic material, on its lower part A^5 for the purpose of securing a tight joint. The head has a hollow stud A^2 , to which an elastic bulb or other device for supplying air may be attached. It is at this part considerably narrowed in diameter. The bent nozzle A proceeds from the top of the head and is provided at its outer end with a cap A' , threaded thereon, which is provided with an orifice a' . The inner tube C passes loosely through the interior of the nozzle and is fitted tightly into the outer end thereof, being slightly enlarged and having small grooves c at this part to allow the escape of air. The lower part of this tube is surrounded by a reinforcing-tube

B, of greater diameter, into which it loosely passes and to which it is secured tightly at the lower end, preferably by means of sweating, as shown in Figs. 1 and 4, or by a screw-thread, as shown in Fig. 2. The outer or reinforcing tube is of lesser internal diameter at this point in order that the two tubes may be tightly joined. The upper end of the tube B is fitted snugly into the upper part of the head and is provided with grooves b' , extending from this end a considerable distance downwardly along the exterior surface thereof. The object of these grooves is to admit air from the passage a^2 into the bottle or other vessel containing the liquid and into the space a between the tube C and nozzle A, leading to the small openings c . The air communicates with the grooves b' through the annular groove b^2 , which is opposite the air-passage a^2 . The indentations b in the end of the tube B allow the air to pass more readily into the space a .

In the modified form of construction shown in Fig. 2 the tube B is secured to the head in the same manner as is shown in Fig. 1. The lower end of the tube has an interior screw-thread adapted to engage the thread c' on the end of the tube C, so that by turning the tube B it may be unscrewed and removed from the inner tube.

What I claim is—

1. In a liquid-atomizer, the combination of an air-supply duct communicating with the interior of the head and the outlet-nozzle, a liquid-discharge tube having a reinforcing-tube surrounding its lower part, secured thereto at its lower end and also detachably fitted into the head bearing the outlet-nozzle.

2. In a liquid-atomizer, the combination of an air-supply duct communicating with the interior of the head and the outlet-nozzle, a liquid-discharge tube having a reinforcing-tube constructed to admit the passage of air from the air-supply duct to the nozzle, surrounding its lower part, secured thereto at its lower end and also fitted into the head bearing the outlet-nozzle and provided with exterior channels communicating with the air-supply duct and extending below the part of the head into which said reinforcing-tube is fitted.

3. In a liquid-atomizer, the combination of

an air-supply duct communicating with the interior of the head and the outlet-nozzle, a liquid-discharge tube having a reinforcing-tube surrounding its lower part, secured thereto at its lower end and also detachably fitted into the head bearing the outlet-nozzle, provided with an annular channel opposite the air-duct and a longitudinal channel leading therefrom to a point below the part of

the head into which said reinforcing-tube is fitted.

Signed at the city of New York, in the county of New York, this 22d day of May, 1900.

EMANUEL J. SONN.

Witnesses:

WILLIAM R. BAIRD,
HERMAN MEYER.