

H. W. WINTER.  
 MACHINE FOR SETTING HEEL AND SOLE PROTECTORS FOR BOOTS AND SHOES.  
 APPLICATION FILED JAN. 2, 1901.

1,001,110.

Patented Aug. 22, 1911.

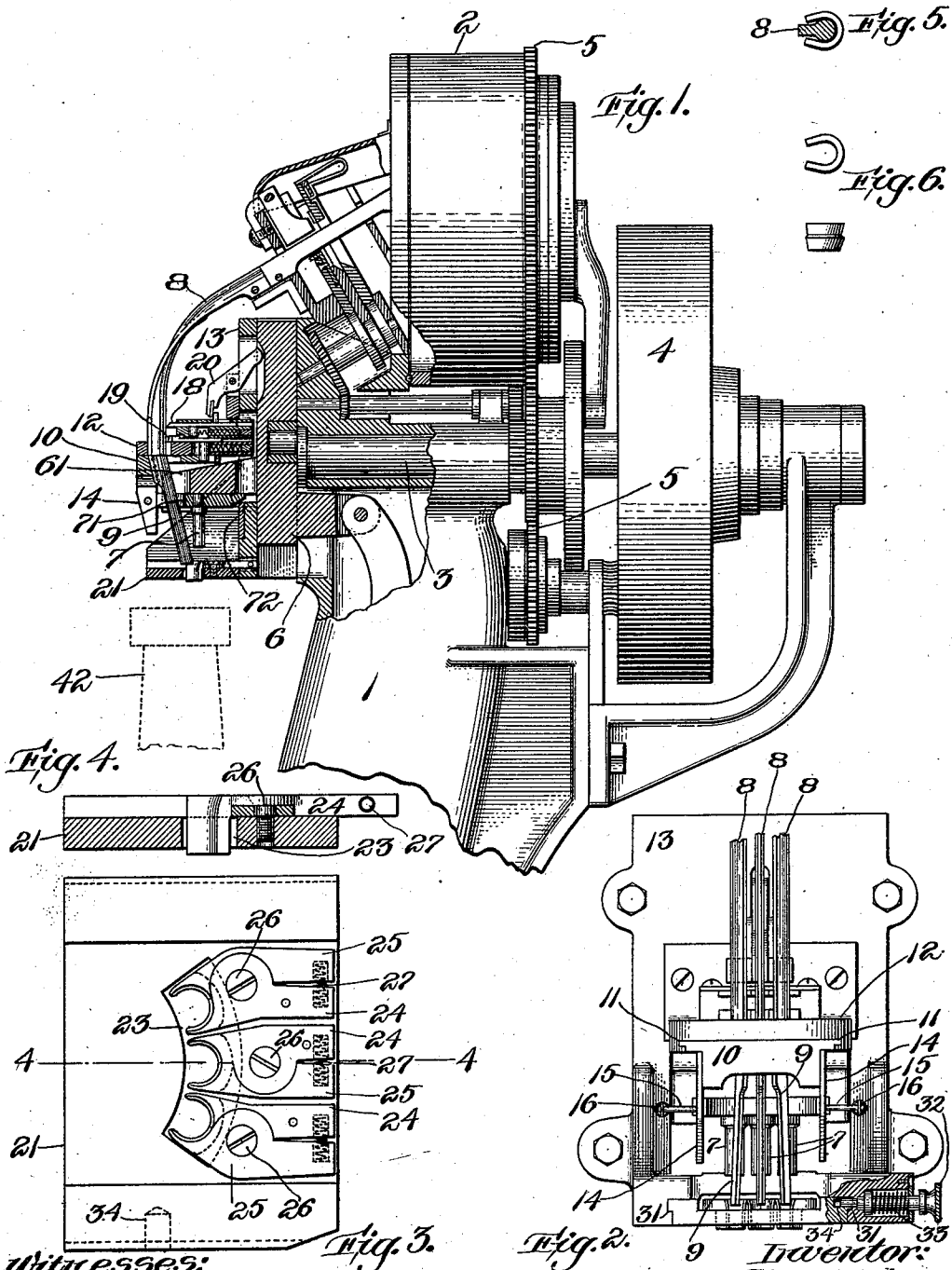

Witnesses:  
*Arthur G. Randall*  
*Oscar F. Hill*

Inventor:  
*Henry W. Winter*  
 by *Maxwell Balcer Randall*  
 Attorneys.

# UNITED STATES PATENT OFFICE.

HENRY W. WINTER, OF LAWRENCE, MASSACHUSETTS, ASSIGNOR TO UNITED SHOE MACHINERY COMPANY, OF PATERSON, NEW JERSEY, AND BOSTON, MASSACHUSETTS, A CORPORATION OF NEW JERSEY.

MACHINE FOR SETTING HEEL AND SOLE PROTECTORS FOR BOOTS AND SHOES.

1,001,110.

Specification of Letters Patent. Patented Aug. 22, 1911.

Application filed January 2, 1901. Serial No. 41,877.

To all whom it may concern:

Be it known that I, HENRY W. WINTER, a citizen of the United States, residing at Lawrence, in the county of Essex, State of Massachusetts, have invented a certain new and useful Improvement in Machines for Setting Heel and Sole Protectors for Boots and Shoes, of which the following is a specification, reference being had therein to the accompanying drawings.

The invention relates to machines for driving or setting metallic reinforces or protectors into the heels and soles of boots and shoes, for the purpose of retarding and equalizing the wear thereof.

In practice, extensive use is made of reinforces or protectors which are formed of strips of metal bent into U-shape or substantially horse-shoe shape, these being applied by being driven edgewise into the leather of the sole or the top-lift of a heel until the edges of such protectors remaining visible are flush with the outer surface of the sole or top-lift, or substantially so.

The present invention is in the nature of an improvement upon the machine which is shown, described and claimed in my prior application for United States Letters Patent filed May 22, 1899, Serial No. 717,674. More especially the invention has reference to devices for use in the said machine and by means of which to accurately position the protectors at the driving point in the machine, and guide them while actually being driven so that the protectors shall stand in the desired position in the work.

The invention consists of guiding devices which I will now proceed to describe, combined with the parts of the said machine and arranged with relation to the said parts as hereinafter is definitely specified.

My invention is illustrated in the accompanying drawings, in which latter I have illustrated the preferred embodiment of the invention.

In the drawings,—Figure 1 shows in side elevation, with some parts in vertical section, the upper portion or head of a machine having applied thereto the present embodiment of my invention. Fig. 2 is a view in elevation, looking from the left in Fig. 1, showing certain parts which are located adjacent the driving place in the machine. Fig. 3 shows in plan the foot-plate. Fig. 4

shows the said foot-plate in vertical transverse section on the plane indicated by the dotted line 4 4 in Fig. 3. Fig. 5 shows in horizontal section a raceway with a protector thereon. Fig. 6 shows views of one form of protector which is adapted to be driven by the aid of my improved devices.

1 designates the supporting post or frame of the machine, 2 is a hopper for protectors mounted suitably at the upper end of said post or frame, 3 is a driving shaft mounted in a suitable bearing or bearings which are provided in the said post or frame, and 4 is a band-pulley on the said driving shaft. Part of a train of gearing for rotating the hopper from the said driving shaft is shown at 5 5. 6 is a slide or plunger for operating the drivers 7 7, etc., the said slide or plunger being actuated by means of a crank on the end of the said driving shaft, as shown in Fig. 1. The said slide or plunger moves vertically in guides or ways which are provided in the head of the machine.

At 61 is shown an arm projecting forwardly, *i. e.*, to the left in Fig. 1, from the slide or plunger 6, and provided with guides or ways in which is mounted with capacity for horizontal movement a driver-block 71 carrying the drivers 7 7. This driver-block is provided with a cam-shaped portion at the right hand thereof in Fig. 1, which in the descent of the slide or plunger 6 makes contact with a fixed part of the head of the machine at 72, Fig. 1, whereby, during the said descent, the drivers are caused to advance toward the left in Fig. 1, thereby placing them in line with the passages through which the protectors are driven, so as to enable the drivers as they continue their descent to enter the said passages. In the subsequent rise of the slide or plunger 6 the driver-block and drivers are allowed to recede to the right in Fig. 1, as soon as they have cleared the passages aforesaid, in order to facilitate the feeding of other protectors in readiness to be driven.

8 8 8 are a series of raceways or roadways leading forward and downward from the hopper 2 for the purpose of conveying the protectors from the hopper toward the place where they are driven. The said raceways or roadways are thin or blade-like to enable them to be straddled by the protectors, and preferably are enlarged or beaded along one

edge thereof throughout the lower portion of their length, as shown most clearly in Figs. 2 and 5, for the purpose of preventing the escape or dislodgment of the protectors after having advanced onto such portion. This longitudinal enlargement or bead of the strip-like raceway is embraced by the slightly converging wings of the protectors.

The raceways 8 8 do not extend all the way to the driver-passages; instead, their lower ends terminate at a short distance above the said driver-passages. Intermediate the said lower ends and the driver-passages I show a series of short raceways 9 9 corresponding in cross-section with the lower portions of the raceways 8 8. The raceways 9 9 are carried by a slide 10 which is mounted with capacity to move horizontally in guides or ways 11 provided on a stand 12 projecting horizontally from the face-plate 13 attached to the head of the machine. The slide 10 is furnished with downwardly projecting arms 14 14 from which project pins 15 15, with which latter connect springs 16 16 acting with a tendency to move the slide 10 toward the right in Fig. 1 of the drawings and to hold the same with the raceways in the position in which they are represented in the said figure. In Fig. 1 the raceways 9 9 bridge the space between the lower ends of the raceways 8 8 and the driver-passages, and hence they may be termed bridging raceways. The front end of the driver-block 71 makes contact with the arms 14 14 of the slide 10, and as the slide or plunger 6 descends, the advance of the driver-block and drivers which is occasioned by the contact of the beveled inner end of the said driver-block with the fixed part 72, causes the slide 10 to be pushed forward, carrying the bridging raceways 9 9 out of line with the raceways 8 8 and the driver-passages, entirely clear of the path of the descending drivers.

Escapement devices are shown for the purpose of regulating the feed of the protectors to the driver-passages, in the shape of spring-projected plates 18 19 which are located at a distance apart vertically corresponding with the height of a protector on the raceways 8 8. The upper plate or plates 18 are retracted in the descent of the slide or plunger 6, through the agency of a lever 20, which last is actuated by a cam-shaped portion of the said slide or plunger; while the plate or plates 19 are retracted, as the slide 10 moves inwardly or to the right in Fig. 1, through the engagement of a part of the said slide with pins carried by the said plate or plates 19.

As thus far described, the devices are constructed and arranged to operate substantially as in the application aforesaid, and I lay no claim herein to the same, separately considered.

In carrying my present invention into effect I form the driver-passages in blocks 24 25, occupying the openings 23 in the foot-plate 21. Each driver-passage is divided, one-half thereof being formed in the forward end of a block 24 and the other in the forward end of a block 25, and the said blocks are relatively movable respecting each other, as, for instance, by adapting one block (25) of each pair to swing horizontally upon a vertical pivot 26, the other block (24) being fixed to the foot-plate, a spiral spring 27 being arranged to close the blocks toward each other. The upper portion of the driver-passage is bell-mouthed, to form a pocket to receive the leading end of a protector as the latter slides off the lower end of a bridging raceway 9, the pocket formed by the bell-mouthed enlarged upper portion of the opening between the forward ends of the blocks being large enough to permit the free entrance of the protector as it drops.

As in the machine of the application aforesaid, the foot-plate 21 is removably applied to the foot of the face-plate 13, it having the opposite side-edges thereof fitted to horizontal slideways or guides 31 31 in the opposite side-portions of said foot, as indicated in Fig. 2, and being secured in place by means of a bolt 32 having applied thereto an actuating spring 33, the said bolt being applied to one of the said side-portions of the said foot, and its inner end being caused to enter a hole 34, Fig. 2, in the adjacent edge of the foot-plate. This construction enables the foot-plate to be removed, whenever necessary, for inspection, repairs, or the like reasons.

At the hopper the protectors are placed upon the upper edge of the top-portion of the blade-like raceway 8, the said portion having its width arranged in a vertical plane. The raceway 8 inclines downwardly and forwardly, and consequently the protectors slide down the same as fast as permitted so to do by the escapement devices. It makes a half-turn, so as to bring the closed or rounded side (back) of a protector to the rear (right hand side in Fig. 1). The position of the protector is determined by the raceway 8 as the protector slides down the latter, and also by the bridging raceway 9 as the protector passes along the latter. The bridging-raceway 9 is of such length that its delivery end projects into the entrance to the driver-passage and thus constitutes an inside guide for the protector by which the latter is positioned as it is deposited within the protector-receiving pocket formed by the upper end of the driver-passage. In the normal closed position of the blocks 24, 25, which is maintained by the action of the spring 27, the protector cannot descend through the lower

portion of the driver-passage between the said blocks, and consequently remains held in the said pocket until the descent of the driver. The pocket holds the protector in the right position for being driven. The said driver-passage below the pocket conforms to the exterior shape of the protector, and consequently as the protector is driven therethrough by the descent of the driver the protector is guided thereby so that it is caused to occupy the desired position in the stock which is supported beneath the foot-plate 21 by the work-support 42, Fig. 1. The driver-passage expands as the protector is driven through the same, and by the compression of the exterior of the protector therein the latter is held from axial displacement.

It is customary to introduce a group of two or more protectors close together into the top-lift of a boot or shoe, or into the sole of a shoe. Satisfactory results as to spacing relative position, etc., of the protectors have not been attained heretofore when the protectors have been driven into place singly, by machine or otherwise. Consequently I have arranged the machine to drive a group of three protectors simultaneously. The driver-passages, accordingly, are three in number, a corresponding number of drivers and raceways being employed, and the relative spacing and inclination of the driver-passages and raceways are the same as the protectors should have when driven into the stock which receives them. Thereby, absolute precision in the spacing and relative positions of the said protectors in a heel or sole is secured, and uniformity of appearance, etc., in the case of successive boots or shoes.

It will be apparent that it is chiefly for constructional reasons that the blocks 24 are made separate from the foot-plate and secured thereto as herein illustrated.

I claim as my invention:—

1. In a machine for setting protectors, in combination, a foot-plate having an expanding driver-passage with a protector-receiving pocket at the entrance thereof, the walls of the said passage acting by pressure against the exterior of the protector to adjust the position in which the protector is set, a raceway delivering a protector into the said pocket and constituting a guide by which the protector is positioned within the pocket, and a driver by which the protector is driven from the said pocket and through the driver-passage into the heel or sole.

2. In a machine for setting winged protectors, in combination, a foot-plate having an expanding driver-passage with a protector-receiving pocket at the entrance thereof, the said passage fitting the opposite sides and closed end of a protector and constituting an outside guide for the latter in

being driven, a raceway which is straddled by the protectors, the delivery end of which enters the said pocket and constitutes an inside guide for the protector as it is deposited within the pocket, and a driver by which the protector is driven from the said pocket and through the driver-passage into the heel or sole.

3. In a machine for setting protectors, in combination, a driver, a foot-plate having an expanding driver-passage, the walls thereof acting by pressure against the exterior of a protector as it is driven therethrough to adjust the position in which such protector is set, a raceway, the delivery end of which enters the entrance to the said driver-passage for the delivery of a protector into the said entrance, and means to withdraw the said delivery end from the path of the driver as the latter acts to drive the protector.

4. In a machine for setting protectors, in combination, a driver, a foot-plate having an expanding driver-passage with an enlarged pocket forming the entrance thereof, the walls of the said driver-passage acting by pressure against the exterior of a protector as it is driven therethrough to adjust the position in which such protector is set, a raceway, the delivery end of which enters the said pocket for the delivery of a protector to the latter, and means to withdraw the said delivery end from the path of the driver as the latter acts to drive the protector.

5. In a machine for driving bent protectors into the heels or soles of boots and shoes, in combination, a supply raceway which determines the position occupied by a protector delivered thereby, a foot-plate having a pocket into which the said raceway delivers and also having a driver-passage in continuation of such pocket, acting by pressure against the exterior of the protector, as the latter is forced therethrough in being driven, to adjust the position in which the protector is set, and a driver acting to force the protector from the said pocket through the driver-passage and into the heel or sole which is held in position to receive the same.

6. In combination, a foot-plate provided with a driver-passage, a raceway along which bent strip protectors are fed successively, delivering a protector edgewise into the mouth of the said driver-passage, and a driver by which the bent protector occupying the said mouth is driven into and then through the driver-passage, the wall of the driver-passage acting upon the exterior of the said protector as the latter is forced ahead of the driver into the driver-passage to adjust the protector around its longitudinal axis in being driven in addition to guiding the same.

7. A machine for driving protectors into the heels or soles of boots and shoes, having means to feed bent protectors successively, and provided with a driver-passage having walls constructed to engage with the exterior of a protector passing through the same and by co-action with such exterior adjust the protector around its longitudinal axis as well as guide the same in being driven, with means to receive a protector from the said feeding means and hold it in register with the said driver-passage, and with a driver to drive the protector thus held through the driver-passage and into the heel or sole held in position to receive the same.
8. In a machine for driving protectors into the heels or soles of boots and shoes, in combination, a foot-plate provided with a driver-passage shaped to determine the position of a bent strip protector in being driven, means to present a protector at the entrance to said driver-passage, and a driver to force such protector into and through the driver-passage and into the heel or sole which is held in position to receive it, the engagement of the walls of the driver-passage with the exterior of the protector, when the latter is forced ahead of the driver into such engagement, adjusting the protector around its longitudinal axis as well as guiding the protector.
9. In a machine for driving bent protectors into the heels or soles of boots and shoes, in combination, a foot-plate provided with a driver-passage constructed to determine the position of a protector in being driven, the said driver-passage having yielding walls, means to present a protector in register with the entrance to the said driver-passage, and a driver to force such protector into and through the passage and into the stock which is to receive it, the yielding engagement of the said walls with the exterior of the protector when the latter is forced into such engagement by the driver guiding the protector and adjusting the latter around its longitudinal axis into the correct position in being set, substantially as described.
10. In a machine for driving horse-shoe shaped protectors, in combination, a group of drivers, a group of blade-like raceways constituting inside guides for the protectors and whereby the protectors are positioned as they pass therefrom, the said raceways delivering the protectors into the paths of the drivers, a foot-plate, and relatively-movable blocks in connection therewith having a group of driver-passages respectively corresponding in contour with the exterior of the protectors, pressing against the exterior of the protectors as the latter pass there-through, and serving to position the protectors in being driven into the stock, substantially as described.
11. In a machine for driving horse-shoe shaped protectors, in combination, a driver, a raceway for protectors, escapement devices for controlling the feed of the protectors, a foot-plate having in connection therewith a driver-passage shaped to conform to the exterior contour of the protector, having yielding walls which permit a protector to be forced therethrough, press against the exterior of a protector in the passage of the latter, and serve to position the protector while the latter is being driven, a bridging raceway constituting an inside guide for the protectors as the latter are delivered thereby, and means to operate said driver and bridging raceway and in the ascent of the driver automatically place the latter raceway in line with the former raceway and the driver-passage, whereby to deliver the protector to the driver-passage and position the same as it passes thereinto, substantially as described.
12. In a machine for driving horse-shoe shaped protectors, in combination, a group of drivers, a group of raceways for protectors, escapement devices whereby the feed of the protectors is controlled, a foot-plate and in connection therewith a group of driver-passages shaped to conform to the exterior contours of the protectors, and having yielding walls which permit protectors to be forced therethrough, press upon the exteriors of the protectors in their passage and serve to position the protectors while being driven, bridging raceways movable into and out of line with the former raceways and the driver-passages and serving to position the protectors as they are delivered therefrom, and means to operate said drivers and bridging raceways, substantially as described.
13. A machine for setting protectors, having a driver, a pocket which holds a bent strip protector in the path of the driver, and a protector-guide in line with the said pocket into which the protector is carried by the driver, the said protector-guide acting at the exterior of the protector to adjust the latter around its longitudinal axis into the correct position in being set.
14. A machine for setting protectors, having a driver, and provided with a protector-holding pocket, a raceway delivering a protector into the said pocket and serving to position the protector within the pocket, and a passage into and through which the protector is driven from the said pocket by the driver in setting the protector, the wall of the said passage coacting with the protector exteriorly to adjust the protector around its longitudinal axis in being set.
15. A machine for setting bent protectors, having a driver, and provided with a protector-holding pocket, and with an expanding guide-passage, the sides of which latter by pressure against the exterior portions of

the protector as it passes therethrough act to adjust the position in which the protector is set, and also having a raceway which delivers a protector into the said pocket and serves to fix the position of the protector in entering the pocket.

16. A machine for setting bent protectors, having a driver, a protector-holding pocket in the path of the driver, a protector-guide engaging with the protector exteriorly of the latter to adjust the position of the same in being set, and a raceway delivering into the said pocket and serving to fix the position of the protector in entering the pocket.

17. A machine for setting protectors, hav-

ing a driver, a raceway by which a bent strip protector is deposited in the path of the driver, and an expanding guide-passage into and through which the protector is forced by the driver, the sides of said guide-passage by pressure against the protector exteriorly acting to adjust the protector around its longitudinal axis in being set.

In testimony whereof I affix my signature, in presence of two witnesses.

HENRY W. WINTER.

Witnesses:

WM. A. MACLEOD,  
ALICE H. MORRISON.

---

Copies of this patent may be obtained for five cents each, by addressing the "Commissioner of Patents, Washington, D. C."

---