

Australia

Patents Act 1990

NOTICE OF ENTITLEMENT

We Aarni Kajaste and Aarre Kilpinen

X of Nokia Telecommunications Oy

Mäkkylän puistotie 1

XX FIN-02600 Espoo

Finland

being authorised by the Applicant(s)/Nominated Person(s) in respect of an application entitled:

Numerically Controlled Oscillator and Digital Phase Locked Loop

state the following:-

1. The Applicant(s)/Nominated Person(s) has/have, for the following reasons, gained entitlement from the actual inventor(s):- The Applicant/Nominated Person, by virtue of a Contract between the actual inventor(s) as employee(s) and the Applicant/Nominated Person as employer, is a person which would be entitled to have the patent assigned to it if a patent were granted on an application made by the actual inventor(s)

2a.* The Applicant(s)/Nominated Person(s) is/are the applicant(s) of the of the basic application(s) listed* on the Patent Request/* in the Declaration under Article 8 of the PCT.

2b.* ~~The Applicant(s)/Nominated Person(s) is/are entitled to rely on the basic application(s) listed* on the Patent Request/* in the Declaration under Article 8 of the PCT as follows:~~

3.* The basic application(s) listed *on the Patent Request/* in the Declaration under Article 8 of the PCT is/are the application(s) first made in a Convention Country in respect of the invention.

4a.* The Applicant(s)/Nominated Person(s) is/are the depositor(s) of the deposit(s) listed in the Schedule hereto.

4b.* ~~The Applicant(s)/Nominated Person(s) has/have the consent of _____, of~~

~~the depositor(s) of the deposit(s) listed in the Schedule hereto, to rely on that/those deposit(s).~~

DATED this 16
Nokia Telecommunications Oy

day of October

19 95

(Signature)

Aarni Kajaste
Patent Coordinator

(Name & Title)

Aarre Kilpinen
Patent Coordinator

* Delete if not applicable.



AU9465706

(12) PATENT ABRIDGMENT (11) Document No. AU-B-65706/94
(19) AUSTRALIAN PATENT OFFICE (10) Acceptance No. 678465

- (54) Title
NUMERICALLY CONTROLLED OSCILLATOR AND DIGITAL PHASE LOCKED LOOP
- International Patent Classification(s)
(51)⁵ H03L 007/099 H03L 007/18
- (21) Application No. : 65706/94 (22) Application Date : 29.04.94
- (87) PCT Publication Number : WO94/26033
- (30) Priority Data
- (31) Number (32) Date (33) Country
931991 03.05.93 FI FINLAND
- (43) Publication Date : 21.11.94
- (44) Publication Date of Accepted Application : 29.05.97
- (71) Applicant(s)
NOKIA TELECOMMUNICATIONS OY
- (72) Inventor(s)
SEPPO PELTOLA
- (74) Attorney or Agent
SPRUSON & FERGUSON , GPO Box 3898, SYDNEY NSW 2001
- (56) Prior Art Documents
EP 459446
EP 388313

(57) Claim

1. Numerically controlled oscillator comprising a first oscillator section having a counter acting as a frequency divider and an external oscillator supplying a clock signal connected to the counter for generating an output signal with a divided frequency from said clock signal, the counter comprising at least one phase control input for connecting phase correction requests to the counter for adjusting the phase of said output signal wherein said numerically controlled oscillator comprises a second accumulator-type oscillator section for controlling the phase of the output signal of the first oscillator section, the second oscillator section comprising an adder and a register, to which the output of the adder is connected, the adder having a first input for connecting a binary digit to control said second oscillator section, and a second input for feeding the output signal of the register back to the adder.

4. Phase-locked loop comprising

a phase comparator having at least two

(11) AU-B-65706/94

-2-

(10) 678465

comparator inputs for comparing the phases of signals connected to the inputs;

a lowpass-type loop filter having an input to which the output of the phase comparator is connected; and

a numerically controlled oscillator arranged to be controlled by the loop filter and comprising a first oscillator section having a counter acting as a frequency divider and an external oscillator supplying a clock signal connected to the counter for generating an output signal with a divided frequency from said clock signal, the counter comprising at least one phase control input for connecting phase correction requests to the counter for adjusting the phase of said output signal wherein said phase-locked loop comprises a second accumulator-type oscillator section for controlling the phase of the output signal of the first oscillator section, the second oscillator section comprising an adder and a register, to which the output of the adder is connected, the adder having a first input connected operationally to the loop filter for connecting the loop filter to control said second oscillator section, and a second input for feeding the output signal of the register back to the adder.



| | | |
|---|--|--|
| <p>(51) International Patent Classification ^S : H03L 7/099, 7/18</p> | <p>A1</p> | <p>(11) International Publication Number: WO 94/26033 (43) International Publication Date: 10 November 1994 (10.11.94)</p> |
| <p>(21) International Application Number: PCT/FI94/00167 (22) International Filing Date: 29 April 1994 (29.04.94) (30) Priority Data: 931991 3 May 1993 (03.05.93) FI (71) Applicant (for all designated States except US): NOKIA TELECOMMUNICATIONS OY [FI/FI]; Mäkkylän puistotie 1, FIN-02600 Espoo (FI). (72) Inventor; and (75) Inventor/Applicant (for US only): PELTOLA, Seppo [FI/FI]; Yliopistonkatu 42 B 212, FIN-90570 Oulu (FI). (74) Agent: OY KOLSTER AB; Iso Roobertinkatu 23, P.O. Box 148, FIN-00121 Helsinki (FI).</p> | <p>(81) Designated States: AT, AU, B2, BG, BR, BY, CA, CH, CN, CZ, DE, DK, ES, FI, GB, GE, HU, JP, KG, KP, KR, KZ, LK, LU, LV, MD, MG, MN, MW, NL, NO, NZ, PL, PT, RO, RU, SD, SE, SI, SK, TJ, TT, UA, US, UZ, VN, European patent (AT, BE, CH, DE, DK, ES, FR, GB, GR, IE, IT, LU, MC, NL, PT, SE), OAPI patent (BF, BJ, CF, CG, CI, CM, GA, GN, ML, MR, NE, SN, TD, TG).</p> <p>Published With international search report. In English translation (filed in Finnish).</p> <p style="font-size: 2em; text-align: center;">678465</p> | |

(54) Title: NUMERICALLY CONTROLLED OSCILLATOR AND DIGITAL PHASE LOCKED LOOP

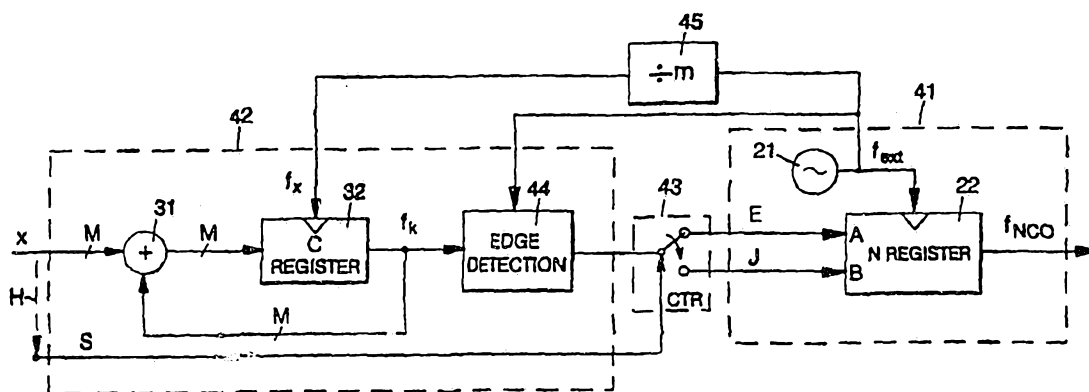

(57) Abstract

The invention relates to a numerically controlled oscillator comprising a first oscillator section (41) having a counter (22) acting as a frequency divider, and an external oscillator (21) supplying a clock signal (f_{ext}) connected to the counter (22) for generating an output signal (f_{NCO}) with a divided frequency from said clock signal, the counter (22) comprising at least one phase control input (A, B) for connecting phase correction requests to the counter (22) for adjusting the phase of said output signal (f_{NCO}) in a desired direction. In order that the gain factor of the oscillator could be diminished and the oscillator could be connected to a digital filter, a second accumulator-type oscillator section (42) known per se is connected to control the first oscillator section (41), the second oscillator section comprising an adder (31) and a register (32), to which the output of the adder is connected, the adder (31) having a first input for connecting a binary digit (x) to control said second oscillator section (42), and a second input for feeding the output signal of the register back to the adder (31). The invention also relates to a phase-locked loop utilizing a numerically controlled oscillator.

Numerically controlled oscillator and digital phase locked loop

5 The invention relates to a numerically controlled oscillator according to the preamble of the attached claim 1, and to a digital phase-locked loop according to the preamble of the attached claim 4, comprising a numerically controlled oscillator.

10 Figure 1 shows a digital phase-locked loop (DPLL) 10 known per se in its general form, in which it comprises a phase comparator 13, a lowpass-type loop filter 14 having an input to which the output signal of the phase comparator is connected, and a numerically controlled oscillator 15 arranged to be
15 controlled by the loop filter. A signal is applied to each one of inputs I1 and I2 of the phase comparator through a frequency divider 11 and 12, respectively. A reference signal f_{ref} is applied to the frequency divider 11, which divides the frequency of the reference signal by an integer p , whereby a signal having a frequency f_{ref}/p (in this text the reference f refers both to the signal and to its frequency) is applied to the first input I1 in the phase comparator 13. The
20 function of the numerically controlled oscillator 15 is to generate a wide range of frequencies from an external clock signal f_{ext} having a frequency higher than that of the output signal f_{NCO} of the oscillator. The output signal of the oscillator is applied through the frequency divider 12 back to the second input I2
25 of the phase comparator 13. The phase comparator thus compares the phase of a signal having the frequency f_{ref}/p with the phase of a signal having the frequency f_{NCO}/q . The result of this comparison is lowpass-filtered in the loop filter 14, and the filtered
30 signal is applied to the oscillator 15 to control it.
35

When the loop is locked, Formula (1) is valid for the output signal of the loop:

$$(1) f_{NCO} = \frac{q}{p} f_{ref}$$

5

i.e. the frequency of the output signal is the frequency of the reference signal multiplied by the number q/p .

In prior art solutions, the numerically controlled oscillator 15 of the digital phase-locked loop is typically implemented in two different ways: either based on a counter or based on an accumulator.

Figure 2 illustrates an implementation of the numerically controlled oscillator 15 based on a counter. In this case, the implementation is based on a counter 22 which divides with a divisor N and the change of state of which is controlled by an accurate clock signal f_{ext} fed from an external oscillator 21 and by a "lead" signal E and a "lag" signal J received as control data from the loop filter and connected to a counter input A and B , respectively, according to the concerned signal. The counter 22 is implemented by an N -state state machine having the above-mentioned signals E and J as its control signals. When the "lead" signal E is true, the state machine steps in place during one clock period, whereby the phase of the output signal f_{NCO} is delayed by one clock period of the clock signal f_{ext} of the external oscillator. When the "lag" signal J is true, the state machine skips one state, whereby the phase of the output signal f_{NCO} is advanced by one clock period of the clock signal f_{ext} of the external oscillator. Accordingly, the length of the phase correction step is always the period length of the output signal f_{NCO} divided with the divisor N .

A drawback of the solution based on the N-counter is that the counter cannot be connected e.g. to a digital filter but it requires a filter of a certain type, such as a so-called lead-lag filter. The digital filter, however, would be a better alternative, as it provides a filter with a narrower bandwidth and, more generally, better properties than the simpler lead-lag filter, for instance.

Figure 3 illustrates an implementation of an accumulator-type numerically controlled oscillator. In this case the oscillator comprises an adder 31 and a register 32, to which the output of the adder is connected. The input signal of the accumulator-type oscillator is a binary (N-bit) digit x applied to a first input in the adder and indicating the magnitude and direction of the required phase correction. The binary digit is obtained from a digital loop filter, and it varies as a function of time in accordance with the filtering result. An output signal f_{NCO} is generated by continuously adding binary digits x to the previous value of the register at the frequency of the external clock signal f_{ext} , which clock signal is connected to a clock input C in the register. At the rising edge of the external clock signal the N-bit value of the output signal y of the adder is stored in the register 32, the value of which indicates the current phase of the output signal. The output signal f_{NCO} of the oscillator is formed by the most significant bit of the register.

The N-bit accumulator-type numerically controlled oscillator generates a frequency obtained from the frequency of the external oscillator in accordance with Formula (2)

$$(2) \quad f_{NCO} = \frac{X}{2^N} \cdot f_{ext}$$

The word width N of the register of the accumulator-type numerically controlled oscillator affects both the gain factor of the oscillator and the highest frequency that can be generated. In order that a relatively low gain factor could be achieved, the word width has to be great; on the other hand, a great word width also increases the length of the adder and thus also the propagation delay of the adder. The accumulator-type numerically controlled oscillator can operate only if the length of the period of the external clock signal ($1/f_{ext}$) exceeds the delay of the adder. For this reason, it is impossible in many applications to achieve a gain factor low enough. The achievement of a low gain factor, however, is important in order that the phase-locked loop could have a narrow bandwidth.

According to a definition known per se, the gain factor K_o of the accumulator-type numerically controlled oscillator is the ratio of a change in an angular frequency applied to the phase comparator to a change Δx in a binary digit x controlling the oscillator:

$$(3) \quad K_o = \frac{\frac{\Delta x}{2^N} \times \frac{2\pi f_{ext}}{q}}{\Delta x} = \frac{2\pi f_{ext}}{2^N q}$$

In the above Formula (3) a constant q is the divisor of the frequency divider (possibly) provided between the output of the oscillator and the second input of the phase comparator (cf. Figure 1).

Another drawback of the accumulator-type oscillator is that the gain factor cannot be set with any particularly high accuracy (it can be set by varying the word width N).

5 The digital phase-locked loop and the accumulator-type numerically controlled oscillator are described e.g. in *Digital Phase-Locked Loop with Jitter Bounded*, Walters, S. M., Troudet T., IEEE Transactions on Circuits and Systems, Vol. 36, No. 7,
10 July 1989, which is referred to for a more detailed discussion.

 The object of the present invention is to avoid the above-described drawbacks and to provide a numerically controlled oscillator which has a gain
15 factor which both can be made low and can be set more accurately than previously and which can also be connected to a digital filter. These objects are achieved by an oscillator according to the invention, which is
20 characterized by what is disclosed in the characterizing portion of the attached claim 1. The phase-locked loop according to the invention, in turn, is characterized by what is disclosed in the characterizing portion of the attached claim 4.

 The idea of the invention is to combine the
25 previously known implementations of the numerically controlled oscillator in such a way that the frequency of the phase correction requests of an oscillator section based on a counter is controlled by an accumulator-type oscillator section.

30 In the following the invention and its preferred embodiments will be described more fully with reference to Figure 4 in the examples shown in the attached drawings, where

 Figure 1 is a block diagram illustrating a
35 digital phase-locked loop known per se;

Figure 2 shows one previously known implementation of the numerically controlled oscillator of the digital phase-locked loop;

5 Figure 3 shows another previously known implementation of the numerically controlled oscillator of the digital phase-locked loop; and

Figure 4 shows an implementation according to the invention of the numerically controlled oscillator of the digital phase-locked loop.

10 Figure 4 is a block diagram illustrating a numerically controlled oscillator implemented according to the invention. The oscillator comprises a first numerically controlled oscillator section 41, which corresponds to the above-described counter-based
15 oscillator implementation shown in Figure 2, where the change of state of a counter 22 is controlled by an accurate clock signal f_{ext} from an external oscillator 21 and by a "lead" signal E and a "lag" signal J, respectively, received as control data. A second
20 numerically controlled oscillator section 42 is connected to control the first oscillator section. The second oscillator section is based on the accumulator-type oscillator shown in Figure 3, comprising an adder 31 and a register 32, to which the output of the adder
25 is connected and the output of which is fed back to one input in the adder. As the first oscillator section 41 corresponds to the counter-based oscillator, and the second oscillator section 42 corresponds substantially to the accumulator-type oscillator,
30 the same reference numerals as in Figures 2 and 3 have been used in Figure 4 for corresponding parts.

The idea of the invention is to adjust the frequency of the phase correction requests (signals E and J) of the counter-based oscillator section 41 by
35 the accumulator-type oscillator section 42, that is,

in fact, by a binary digit x , as the accumulator-type oscillator is controlled by a binary digit, and additionally by a signal S indicating the direction of the phase correction. To effect the control, phase control
5 inputs A and B in the first oscillator section are connected to respective outputs in a selector 43, and a selector input is connected to an output in the second oscillator section. The selector is controlled by the direction signal S , which is connected to a
10 control input CTR in the selector. The direction signal S determines whether the output of the second oscillator section 42 is connected to the input A in the first oscillator section, corresponding to the "lead" signal, or to the input B in the first oscillator section, corresponding to the "lag" signal.
15

The second oscillator section 42 corresponds otherwise to the accumulator-type oscillator shown in Figure 3 except that the output signal of the register 32, now indicated with the reference f_k , is connected
20 to an edge detector circuit 44, the output of which forms an output in the second oscillator section 42, which output is connected to an input in the selector 43. The edge detector circuit detects the rising edges of the output signal f_k and shapes the signal such that its pulse width corresponds to the pulse width of
25 the external clock signal f_{ext} (which controls the N counter 22).

A signal obtained from the register 32 of the second oscillator section thus has a frequency which
30 can be obtained as follows:

$$(4) \quad f_k = \frac{X}{2^M} f_x$$

This frequency is also the frequency of pulses from the output of the edge detector circuit, that is, a signal having this frequency either advances or delays the phase of the counter 22 of the first oscillator section. The frequency of the numerically controlled oscillator according to the invention can now be calculated from Formula (5):

$$(5) \quad f_{NCO} = \frac{f_{ext}}{N} \pm \frac{x f_x}{2^M N}$$

In Formula (5), the sign of the \pm operation depends on the sign of the phase correction signal S. On the basis of Formula (5), it is possible to calculate the gain factor of the numerically controlled oscillator shown in Figure 4, which factor, according to a definition known per se, is the ratio of a change in an angular frequency applied to the phase comparator of the phase-locked loop to a change in the controlling binary digit x. The gain factor will thus be:

$$(6) \quad K_o = \frac{2\pi \Delta f_{NCO}}{\Delta x} = \frac{2\pi \frac{\Delta x f_x}{2^M N}}{\Delta x} = \frac{2\pi f_x}{2^M N q}$$

where a constant q is the divisor of a frequency divider (possibly) provided between the output of the oscillator and the input of the phase comparator in the feedback loop of the phase-locked signal.

It appears from Formula (6) that a low gain factor is easy to achieve in the oscillator according to the invention by setting the frequency of the signal f_x to a low value, whereby the value of the

gain factor also diminishes. The signal f_x controlling storing into the register 32 is, in fact, advantageously obtained by dividing the frequency of the signal f_{ext} from the external oscillator 21 of the first oscillator section 41 by a divisor m in a frequency divider 45. The frequency of the signal f_x is thus considerably lower than that of the signal f_{ext} .

The numerically controlled oscillator shown in Figure 4 can be connected to a digital loop filter, as the desired control signals x and S are obtained directly from the digital filter, or the output signal of the digital filter is at least easy to shape so that the desired control signals are obtained. The direction signal S , for instance, may be contained in a binary word x obtained from the loop filter, and it can be extracted from the binary word into a separate control signal, which is connected, as described above, to control the selector 43. (In Figure 4, this alternative is shown by an arrow H drawn by a broken line).

Even though the invention has been described above with reference to the examples of the attached drawings, it is self-evident that the invention is not limited to the examples, but it may be modified within the inventive idea disclosed above and in the attached claims. For instance, the more detailed switching arrangements of the oscillator and the phase-locked loop may vary, even though the accumulator-type oscillator section is connected to control the counter-type oscillator section in accordance with the idea of the invention. Essential is that the accumulator-type oscillator section controls the counter-type oscillator section, whereas it is not essential in which way it is connected to control the counter-type oscillator section, i.e. whether it is connected to the

counter-type oscillator section directly or through various intermediate circuits irrelevant to the idea of the invention. The solution according to the invention is not only applicable in all digital phase locks where the oscillator is controlled by a binary word but, in principle, it is also possible to use the invention in other applications where a similar control is available.

The claims defining the invention are as follows:

1. Numerically controlled oscillator comprising
 a first oscillator section having a counter acting as
 5 a frequency divider and an external oscillator
 supplying a clock signal connected to the counter for
 generating an output signal with a divided frequency
 from said clock signal, the counter comprising at
 10 least one phase control input for connecting phase
 correction requests to the counter for adjusting the
 phase of said output signal wherein said numerically
 controlled oscillator comprises a second accumulator-
 type oscillator section for controlling the phase of
 15 the output signal of the first oscillator section, the
 second oscillator section comprising an adder and a
 register, to which the output of the adder is
 connected, the adder having a first input for
 connecting a binary digit to control said second
 oscillator section, and a second input for feeding the
 20 output signal of the register back to the adder.

2. Oscillator according to claim 1, comprising
 two phase control inputs, wherein said accumulator-
 type oscillator section is operationally connected to
 one of the phase control inputs through a selector,
 25 which comprises means for connecting a signal present
 at its input to a desired output.

3. Oscillator according to claim 1, wherein a
 clock input in said register, to which a clock signal
 is connectable to control storing into the register,
 30 is connected to said external oscillator through a
 frequency divider for dividing the frequency of the
 signal from the external oscillator before connecting
 it to the clock input in the register.

4. Phase-locked loop comprising
 35 a phase comparator having at least two



comparator inputs for comparing the phases of signals connected to the inputs;

5 a lowpass-type loop filter having an input to which the output of the phase comparator is connected; and

10 a numerically controlled oscillator arranged to be controlled by the loop filter and comprising a first oscillator section having a counter acting as a frequency divider and an external oscillator supplying a clock signal connected to the counter for generating an output signal with a divided frequency from said clock signal, the counter comprising at least one phase control input for connecting phase correction requests to the counter for adjusting the phase of said output signal wherein said phase-locked loop comprises a second accumulator-type oscillator section for controlling the phase of the output signal of the first oscillator section, the second oscillator section comprising an adder and a register, to which the output of the adder is connected, the adder having a first input connected operationally to the loop filter for connecting the loop filter to control said second oscillator section, and a second input for feeding the output signal of the register back to the adder.

25 5. Phase-locked loop according to claim 4, comprising two phase control inputs wherein said accumulator-type oscillator section is operationally connected to one of the phase control inputs through a selector, which comprises a control input operationally connected to the loop filter for connecting the loop filter to control the switching of a signal present at the selector input to a desired selector output.

35



6. Phase-locked loop according to claim 4, wherein a clock input in said register, to which a clock signal is connectable to control storing into the register, is connected to said external oscillator through a frequency divider for dividing the frequency of the signal from the external oscillator before connecting it to the clock
5 input in the register.

7. A numerically controlled oscillator substantially as hereinbefore described with reference to Fig. 4 of the accompanying drawing.

8. A phase-locked loop substantially as hereinbefore described with reference to Fig. 4 of the accompanying drawing.

10

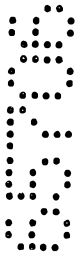

DATED this Twelfth Day of March 1997

Nokia Telecommunications OY

Patent Attorneys for the Applicant

SPRUSON & FERGUSON

15

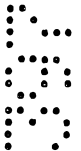

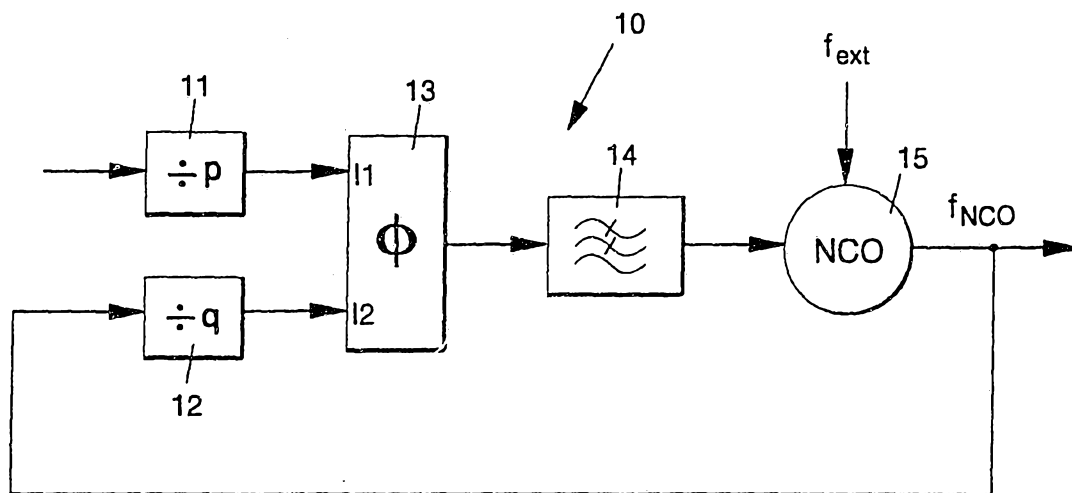

FIG. 1

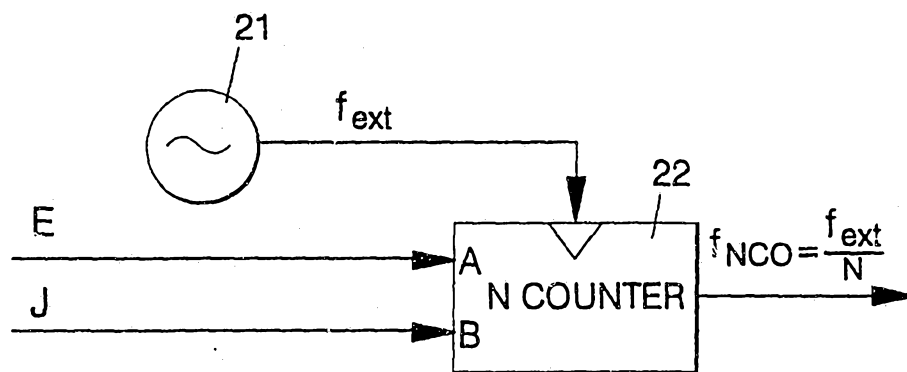

FIG. 2

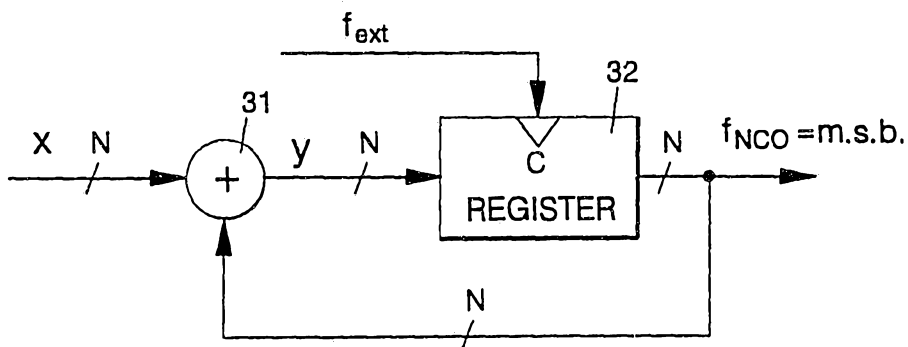

FIG. 3

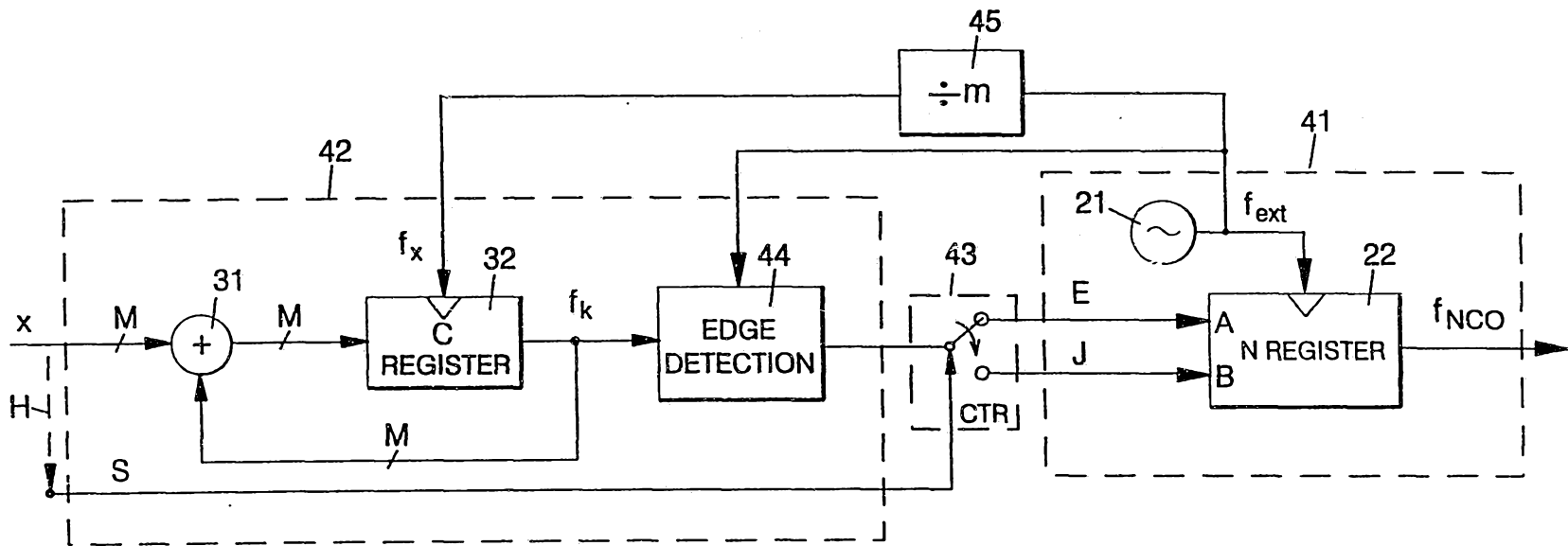

FIG. 4

INTERNATIONAL SEARCH REPORT

International application No.

PCT/FI 94/00167

| A. CLASSIFICATION OF SUBJECT MATTER | | |
|---|--|--|
| IPC : H03L 7/099, H03L 7/18 According to International Patent Classification (IPC) or to both national classification and IPC | | |
| B. FIELDS SEARCHED | | |
| Minimum documentation searched (classification system followed by classification symbols) | | |
| IPC : H03L | | |
| Documentation searched other than minimum documentation to the extent that such documents are included in the fields searched | | |
| SE,DK,FI,NO classes as above | | |
| Electronic data base consulted during the international search (name of data base and where practicable, search terms used) | | |
| C. DOCUMENTS CONSIDERED TO BE RELEVANT | | |
| Category* | Citation of document, with indication, where appropriate, of the relevant passages | Relevant to claim No. |
| A | CA, A, 1161910 (MULTI-DIMENSION LTD), 7 February 1984 (07.02.84), page 5, line 6 - page 7, line 32, figures 1,3 -- | 1-6 |
| A | EP, A2, 0388313 (JOHN FLUKE MFG. CO., INC.), 19 Sept 1990 (19.09.90), page 4, line 35 - page 6, line 39, figures 2,3 -- | 1-6 |
| A | EP, A1, 0459446 (SONY CORPORATION), 4 December 1991 (04.12.91), see the whole document -- ----- | 1-6 |
| <input type="checkbox"/> Further documents are listed in the continuation of Box C. <input checked="" type="checkbox"/> See patent family annex. | | |
| * Special categories of cited documents: "A" document defining the general state of the art which is not considered to be of particular relevance "E" earlier document but published on or after the international filing date "L" document which may throw doubts on priority claim(s) or which is cited to establish the publication date of another citation or other special reason (as specified) "O" document referring to an oral disclosure, use, exhibition or other means "P" document published prior to the international filing date but later than the priority date claimed "T" later document published after the international filing date or priority date and not in conflict with the application but cited to understand the principle or theory underlying the invention "X" document of particular relevance: the claimed invention cannot be considered novel or cannot be considered to involve an inventive step when the document is taken alone "Y" document of particular relevance: the claimed invention cannot be considered to involve an inventive step when the document is combined with one or more other such documents, such combination being obvious to a person skilled in the art "&" document member of the same patent family | | |
| Date of the actual completion of the international search | | Date of mailing of the international search report |
| 9 August 1994 | | 11-08-1994 |
| Name and mailing address of the ISA/ Swedish Patent Office Box 5055, S-102 42 STOCKHOLM Facsimile No. +46 8 666 02 86 | | Authorized officer Bo Gustavsson Telephone No. +46 8 782 25 00 |

INTERNATIONAL SEARCH REPORT

Information on patent family members

02/07/94

International application No.

PCT/FI 94/00167

| Patent document cited in search report | Publication date | Patent family member(s) | Publication date |
|--|------------------|--------------------------------|----------------------|
| CA-A- 1161910 | 07/02/84 | NONE | |
| EP-A2- 0388313 | 19/09/90 | JP-A- 2280415 US-A- 4951004 | 16/11/90 21/08/90 |
| EP-A1- 0459446 | 04/12/91 | JP-A- 4037205 US-A- 5153526 | 07/02/92 06/10/92 |