

J. GREEN.  
CAR TRUCK.

APPLICATION FILED APR. 15, 1904.

NO MODEL.

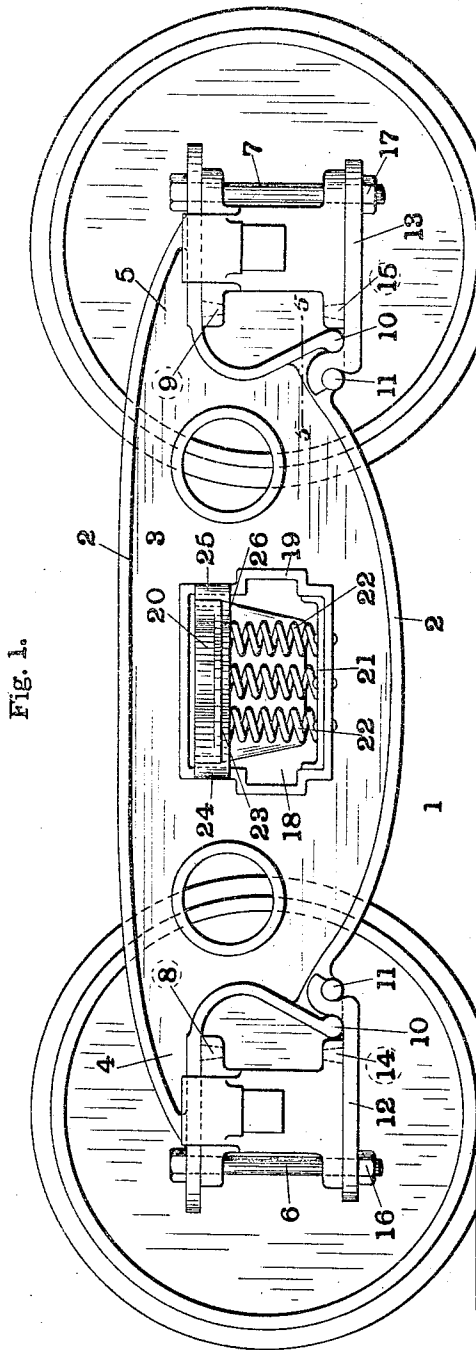

Fig. 1.

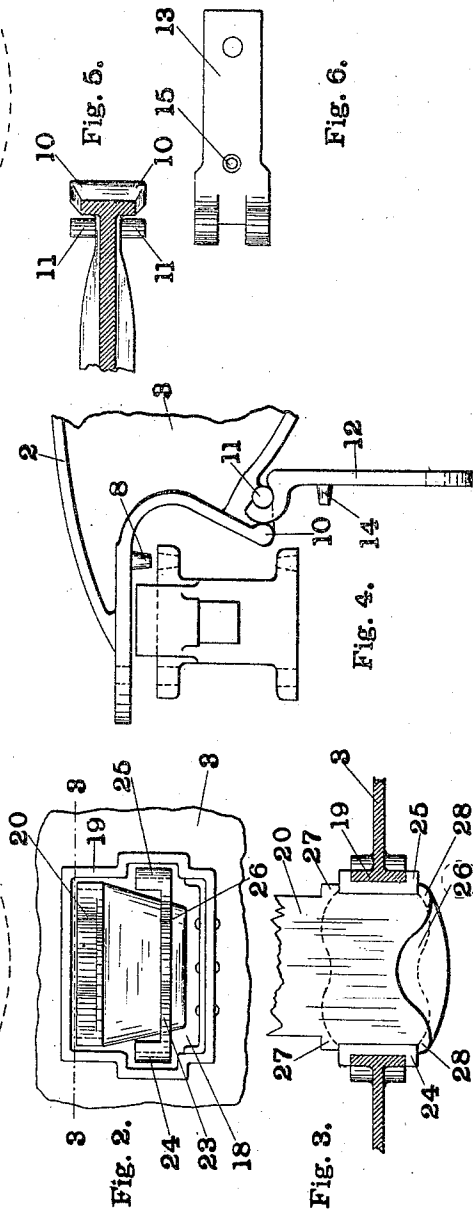

Fig. 2.

Fig. 3.

Fig. 4.

Fig. 5.

Fig. 6.

Witnesses:

G. Orme

Prof. P. Orme

Inventor:

By

John Green,  
Carr & Carr,

Attorneys.

# UNITED STATES PATENT OFFICE.

JOHN GREEN, OF ST. LOUIS, MISSOURI.

## CAR-TRUCK.

SPECIFICATION forming part of Letters Patent No. 773,564, dated November 1, 1904.

Application filed April 15, 1904. Serial No. 203,241. (No model.)

*To all whom it may concern:*

Be it known that I, JOHN GREEN, a citizen of the United States, and a resident of the city of St. Louis and State of Missouri, have invented a new and useful Improvement in Car-Trucks, of which the following is a specification.

My invention relates to car-trucks, and especially to side frames therefor, and has for its principal objects to provide a cast side frame which may be assembled with the bolster without making any part of the truck removable, to provide a side frame so arranged that the truck-bolster can be inserted endwise into the side frame, to provide a side frame with removable bolster-guides, to provide a side frame having removable bolster-guides to be applied after the truck-bolster has been put in place, to provide a side frame having integral journal-box-retaining lugs, to provide a side frame so connected to the journal-boxes that the latter can be removed without raising the side frame a distance equal to the height of the journal-box, to provide a side frame having pivoted journal-box-retaining means, to provide a side frame with removable journal-box-retaining means which will not fall out of its own weight, and other objects hereinafter more fully appearing.

My invention consists in the parts and in the arrangements and combinations of parts hereinafter described and claimed.

In the accompanying drawings, forming a part of this specification, and wherein like symbols refer to like parts wherever they occur, Figure 1 is a side view of my improved truck. Fig. 2 is a view of the central portion of the side frame, showing the manner in which the removable bolster-guides are inserted. Fig. 3 is a fragmentary view on the line 3 3 of Fig. 2. Fig. 4 is a view showing the end of the side frame arranged for insertion or removal of the journal-box. Fig. 5 is a fragmentary view on the line 5 5 of Fig. 1, the journal-box-retaining bar being removed; and Fig. 6 is a plan view of a journal-box-retaining bar.

The side frame 1 is provided with a peripheral flange 2, the web 3 being comparatively thin. There are projecting shoulders 4 5 at

the upper corners. Near the outer extremity of each shoulder is a bolt-hole through which bolts 6 7, respectively, may pass. In hitherto-known forms of side frames it has been customary to provide bolt-holes near the point at which the shoulders join the body portion of the frame. This is objectionable, as it weakens the frame at the point at which it is subjected to considerable strain. It also involves expense to drill or ream out the holes. On the present side frame lugs 8 9 are provided upon the lower side of the shoulders 4 5, respectively, in position to engage the holes in ears on the journal-box ordinarily provided to receive securing-bolts. Upon each of the lower corners of the side frame are oppositely-extending pairs of round lugs 10 11, integral with the side frame. Journal-box-retaining bars 12 13 are secured by means of the said lugs 10 11. The end of each bar toward the side frame is bifurcated and curved to fit under the lugs 10 and over the lugs 11. The curved bifurcated portion is so long that the bar must swing past the position in which it would be held by gravity before it can be disengaged from the lugs 10 11. Thus the bar is securely held against dropping-off while being easily removable at will. By this construction the objectionable use of bolts and nuts is avoided. The bars are secured by parts integral with or permanently a part of the body portion of the truck-frame or the bars. By parts "permanently a part of" the structure are meant parts the removal of which is unnecessary to permit the removal of the bars. Lugs 14 15 are provided on the bars 12 13, respectively, near their pivot-points, so that they will be immediately beneath the lugs 8 9, respectively, when the bars are in a horizontal position. These lugs are in position to engage the holes in ears on the lower corners of the journal-boxes. At their outer ends the bars are provided with bolt-holes. The bolts 6 7 pass through the bolt-holes in the shoulders 4 5 and retaining-bars 12 13, respectively, and through holes in ears upon the journal-boxes. Nuts 16 17 on the bolts 6 7, respectively, hold the retaining-bars 12 13, respectively, in a substantially horizontal position. The jour-

nal-boxes are thus securely retained in position. When it is desired to remove the journal-boxes, it is only necessary to remove the bolts and jack up the side frames a height  
5 equal to the length of the lugs 8 9. The wheels can then be rolled away from the truck, the journal-boxes moving out horizontally.

Near the middle the side frame has a substantially rectangular opening 18, which is  
10 bounded by a flange 19. The sides of said opening are integral in the bolster illustrated; but permanently-connected sides, as in a built-up truck-frame, would be equally within the  
15 scope of my invention. The lower middle portion of the opening is wider than the upper portion thereof for a purpose hereinafter appearing. The upper portion of the opening 18 is wide enough to permit the insertion  
20 endwise of the bolster 20 to be used therewith. In other words, its width is equal to the width of the bolster measured over the column-guides thereon. A cross-tie 21, having  
25 seats for springs 22, is secured to the flange on the lower side of the opening 18. The bolster 20 is guided in the frame by means of a bolster-guide member 23, comprising bolster-guides 24 25 and a connecting-plate 26,  
30 integral therewith. The bolster-guides are substantially U-shaped in horizontal section and are arranged to embrace the flanges forming the vertical sides of the upper narrow portion of the opening 18. Their outside dimensions  
35 are such that they fit between the column-guides 27 28 on the bolster. The springs 22 are seated between the lower side of the opening 18 and the plate 26 of the bolster-guide member 23. Thus the bolster-guide member will vibrate with the bolster and will  
40 be guided by the vertical walls of the narrower portion of the opening 18. The outside dimensions of the bolster-guide member 23 are such that it may be inserted in the wider portion of the opening 18. In assembling the  
45 truck the bolster is inserted. Then the bolster-guide member 23 is inserted in the wider portion of the opening 18 and slipped up between the column-guides on the bolster. Then the springs are placed in position.

Obviously the device admits of modification within the scope of my invention, and therefore I do not wish to be limited to the specific construction shown and described as an illustration of my invention. For example,  
55 although a cast frame is shown in the drawings the invention is equally applicable to a built-up frame.

What I claim as my invention, and desire to secure by Letters Patent, is—

60 1. A car-truck comprising a truck-frame provided with an opening to receive the end of a bolster, a bolster provided with column-guides, and bolster-guides extending between said column-guides and removably mounted  
65 in said opening to move with said bolster.

2. A car-truck comprising a bolster provided with column-guides, a side frame provided with an opening to receive the end of said bolster, the upper portion of said opening  
70 being as wide as the outside dimensions of said end over said column-guides, connected bolster-guides adapted to be inserted from beneath between said column-guides and to engage the vertical sides of said upper portion  
75 of said opening, a portion of said opening below said upper portion being at least as wide as the outside dimensions of said bolster-guides, and springs mounted upon the lower side of said opening and supporting said bolster and bolster-guides.  
80

3. A car-truck comprising a truck side frame provided with a bolster-receiving opening bounded by permanently-connected sides, a bolster, and removable bolster-guides arranged to embrace said bolster and engage the  
85 sides thereof and to engage the sides of said opening.

4. A truck side frame comprising a body portion having an opening therein bounded by permanently-connected sides and substantially  
90 U-shaped bolster-guides removably secured in said opening to embrace the vertical sides thereof and arranged to embrace a bolster extending into said opening.

5. A truck side frame comprising a body  
95 portion having an opening therein to receive the end of a bolster, and bolster-guides arranged to embrace a bolster extending into said opening and adapted to be slipped into position from beneath the bolster after the  
100 bolster is in place.

6. A truck side frame comprising a body portion having an opening with permanently-connected sides to receive the end of a bolster, and bolster-guides removably embracing  
105 the vertical sides of said opening, arranged to embrace the end of a bolster extending into said opening and adapted to be slipped into position from below the bolster after the bolster is in place.  
110

7. A truck side frame comprising a body portion provided at its opposite ends with journal-box-receiving recesses open at at least one side and an integral lug upon one side of each of said recesses in position to enter a  
115 bolt-hole in a journal-box when in position in said recess.

8. A truck side frame comprising a body portion having integral projecting shoulders at its upper corners, arms pivotally mounted  
120 upon the lower corners of said body portion, and means on each of said shoulders and each of said arms and integral therewith in position to enter bolt-holes in a journal-box and to retain the journal-box in position therebetween.  
125

9. A truck side frame comprising a body portion having projecting shoulders at its upper corners and pivotally-connected arms at its  
130 lower corners, lugs upon the under surfaces of

said shoulders near the point at which the shoulders join the body portion and lugs upon the upper surfaces of said arms vertically beneath the lugs upon said shoulders, said shoulders and said arms being provided with aligned bolt-holes near their outer extremities.

10. A car-truck comprising a truck side frame provided with a bolster-receiving opening bounded by permanently-connected sides, a bolster, removable bolster-guides arranged to engage the sides of said opening, and interlocking means on said bolster and said bolster-guides, whereby said bolster will be retained in said opening until said bolster-guides are removed.

11. A truck-frame comprising a body portion having recesses for journal-boxes open at least one side, and journal-box-retaining bars to form one side of the recesses, respectively, pivotally and removably mounted on said body portion in such manner that the bars must swing past the position in which they would be held by gravity before they can be detached.

12. A truck-frame comprising a body portion having recesses for journal-boxes open at least one side, spaced members upon said body portion at one corner of each of said recesses, and a journal-box-retaining bar for each recess provided with a curved portion to interlock with said spaced members for pivotal movement.

13. A car-truck comprising a truck side frame provided with a bolster-receiving opening having permanently-connected imperforate sides, a bolster provided with column-guides, and removable bolster-guides extending between said column-guides and engaging the sides of said opening.

14. A car-truck comprising a side frame having recesses for journal-boxes open at least one side, a journal-box in each of said recesses provided with holes to receive retaining means, a projection integral with one side of the recess arranged to enter the hole in said journal-box, a pivotally-mounted retaining-bar to form one side of the recess and having an integral projection arranged to enter a hole in said journal-box, and a bolt connecting one end of said bar with said side frame and passing through holes in said journal-box.

15. A car-truck comprising a side frame having projecting shoulders at its upper corners, journal-boxes located beneath said shoulders and provided with holes to receive retaining means, an integral lug upon the under surface of each of said shoulders in position to enter one of said holes, and arms connected to the lower corners of said side frame and provided with integral lugs upon their upper surfaces in position to engage others of said holes in said journal-boxes.

16. A car-truck comprising a truck side frame provided with a bolster-receiving opening bounded by permanently-connected sides, a bolster, and removable bolster-guides arranged to engage the sides of said opening, said bolster and bolster-guides being relatively fixed with respect to longitudinal movement when in position in said opening.

In testimony whereof I have signed my name to this specification in the presence of two subscribing witnesses.

JOHN GREEN.

In presence of—

FRED F. REISNER,  
J. B. MEGOWN.