

Oct. 14, 1958

S. L. WOLFE ET AL

2,856,111

GUN CARRIER

Filed Dec. 19, 1955

2 Sheets-Sheet 1

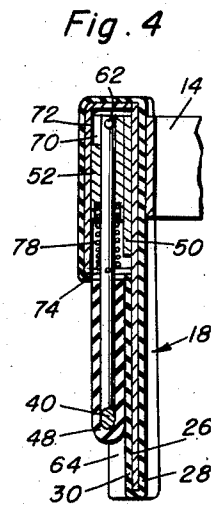
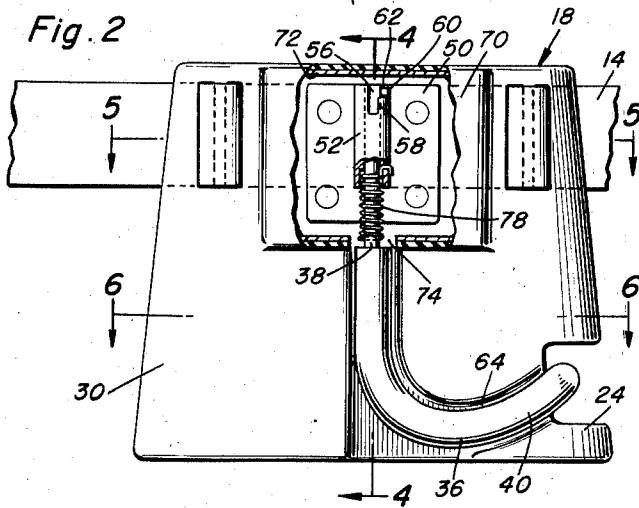
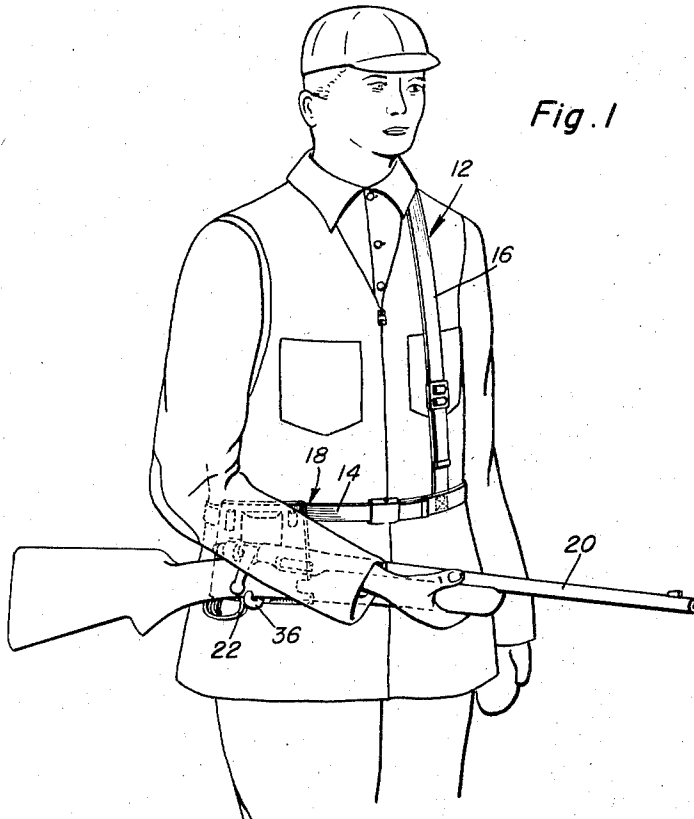

Stephen L. Wolfe
Howard L. Wallis
INVENTORS.

BY *Alvin A. Simon*
and Harvey B. Jacobson
Attorneys

Oct. 14, 1958

S. L. WOLFE ET AL

2,856,111

GUN CARRIER

Filed Dec. 19, 1955

2 Sheets-Sheet 2

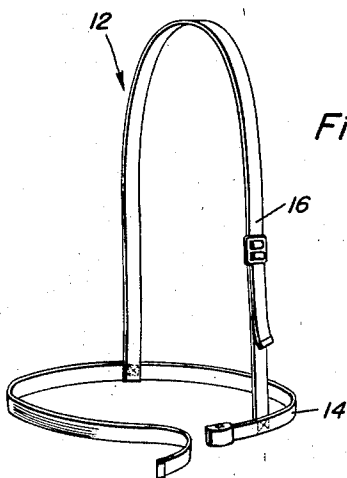
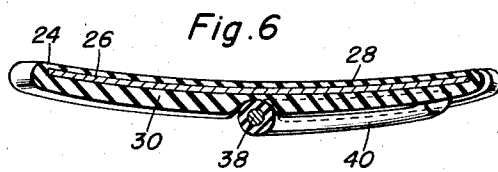
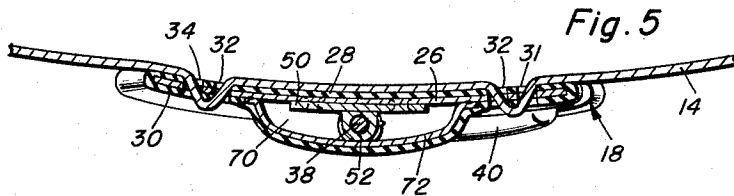
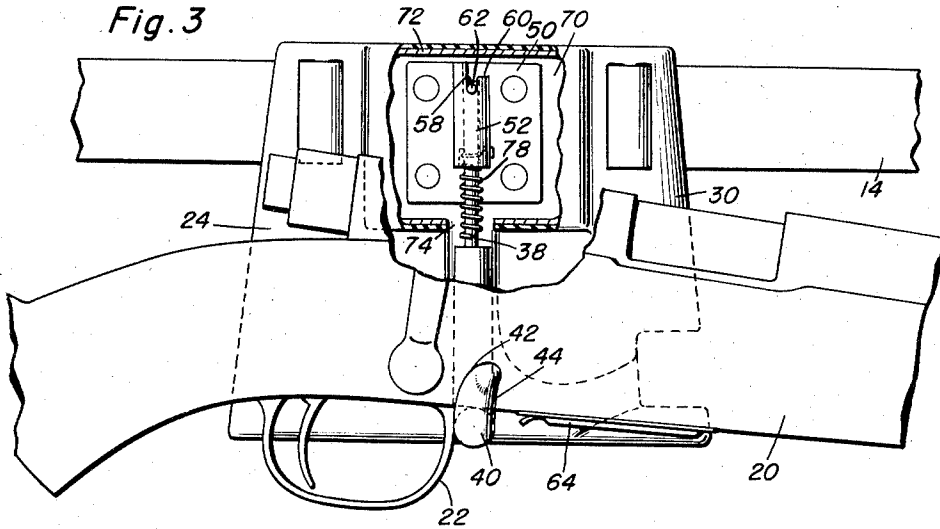

Stephen L. Wolfe
Howard L. Wallis
INVENTORS.

BY *Oliver A. Olson*
and Harvey B. Jackson
Attorneys

1

2,856,111

GUN CARRIER

Stephen L. Wolfe and Howard L. Wallis,
Johnsontown, Pa.

Application December 19, 1955, Serial No. 553,778

8 Claims. (Cl. 224-5)

This invention relates to improvements in gun carriers.

An object of the present invention is to provide a gun carrier of the type which is carried by a body strap on a hunter, the carrier having a cradle on which the gun is supported in a safe and convenient manner and upon removal of the gun from the cradle, the latter automatically returns to a rest position flush against the cradle support.

A further object of the invention is to provide a gun carrier of the type wherein there is a body strap supporting a panel on the hunter, a cradle mounted for rotation on the panel, a dual functioning spring to both unlatch the cradle immediately upon removal of the gun therefrom and to return the cradle to a rest position flush with or closely adjacent to the surface of the support. In this way there is no objectionable protrusion from the hunter's clothing such as would become caught or tangled with the hunter's arm.

Another object of the invention is to provide a gun carrier which enables the hunter to have his gun always ready for immediate action and yet supports the gun in a manner that is safe there being no possibility of any part of the carrier becoming engaged with the rifle trigger.

A further object of the invention is to provide a carrier adapted primarily to support rifles, this carrier being a practical device which attaches to the hunter's body strap and in such position that the rifle is readily available for instantaneous use.

These together with other objects and advantages which will become subsequently apparent reside in the details of construction and operation as more fully hereinafter described and claimed, reference being had to the accompanying drawings forming a part hereof, wherein like numerals refer to like parts throughout, and in which:

Figure 1 is a perspective view of a part of a hunter showing the rifle carrier in use;

Figure 2 is a front view of the rifle carrier with parts broken away in section to illustrate internal detail;

Figure 3 is a fragmentary elevational view with parts shown in section of the rifle carrier, there being a rifle mounted thereon;

Figure 4 is a sectional view taken on the line 4-4 of Figure 2;

Figure 5 is a sectional view taken on the line 5-5 of Figure 2;

Figure 6 is a sectional view taken on the line 6-6 of Figure 2; and

Figure 7 is a perspective view of the body strap to which the gun carrier is attached.

In the accompanying drawings the hunter has a body strap 12 which is of a selected type from the many body straps which hunters use. The selected body strap includes a belt 14 provided with some type of fastener, as a buckle, together with a shoulder strap 16 which is adjustable. Although the gun carrier 18 is shown attached to the belt 14 of the body strap, it may be attached to other places on the body strap or may be mounted in other

2

locations with respect to the hunter's body depending on which type of body strap is selected.

Rifle 20 as shown in Figure 1, is in readiment for use by the hunter. This rifle is conventional and includes all of the conventional parts of a rifle, such as the trigger guard 22. Carrier 18 consists of a support 24, the latter preferably but not exclusively, being made of leather or plastic and in laminated form (Figure 4). There is a metal panel 26 for strength and stiffening, this panel being covered on its front and rear surfaces by means of plies 28 and 30 of leather, plastic or other material. Panel 26 and the plies 28 and 30 are smoothly curved from one side edge to the other in order to conform generally to the body of the hunter. In addition, these parts of the carrier have two pairs of slots including slots 31, 32 and slots 33, 34. Accordingly the belt 14 may be attached to the carrier by being threaded through these pairs of slots (Figure 5).

A rifle cradle 36 is mounted on the support 24, this cradle being made of a shank 38 whose lower end is smoothly curved to form a hook 40 whose end is specially contoured (Figure 10). This specially contoured end is made by smoothly curving one side 42 in a large radius arc to merge with a substantially straight opposite side 44. The purpose of this is to permit the trigger guard 22 to slide over the end of the cradle smoothly, thereby minimizing the possibility of having the rifle trigger guard snag thereon. The upper end of shank 38 is left bare, while the lower end thereof including hook 40 is covered with a material which is softer than metal so as to prevent marring of the rifle surface. Examples of such covering material 48 are leather and plastic or rubber.

A mounting plate 50 is attached to the panel 26 near the upper end thereof. Sleeve 52 having open upper and lower ends, is fixed to the mounting plate and has one end of shank 38 mounted for rotation therein. Latch 56 is arranged at the top of shank 38 and consists of a slot 58 which extends longitudinally of the sleeve 52, together with a land 60 at the upper end of sleeve 52. Pin 62 is secured to the upper end of the shank 38 and protrudes laterally therefrom. This pin is adapted to ride on land 60 and to be engaged in slot 52. When in slot 52 the hook 36 protrudes generally perpendicular to the plane of the carrier support 24. When pin 62 is on land 60, the hook 36 is generally flush with the surface of support 24. In this position the hook and shank is fitted in a recess 64 formed in the carrier support in order to accommodate these elements.

Plate 50, sleeve 52 and the other elements associated with them are in a small housing 70 formed by raising the ply 30 near the top thereof and having a stiffening plate 72 mounted thereunder. This plate is shaped to form the desired configuration of the housing 70 that is, a housing of sufficient depth to accommodate the pivot connection of the shank 38 with the support 24. The lower end of the housing has an opening 74 in it, this opening providing a passageway through which shank 38 extends.

Resilient means are attached to the sleeve 52 and to the shank 38, these means functioning to serve two purposes. The first purpose is to constantly press by yielding force, the hook 40 into its recess 64. In this way the hook when not in use is maintained in a position which will not interfere with the actions of the hunter. The second function of spring 78 is to automatically release the latch at the outer end of shank 38. When the latch retains hook 40 extended generally perpendicular to the support 24 the pin 62 is seated in slot 38. However, the spring 78 must be stretched to permit the pin to be pulled downwardly into slot 38 inasmuch as spring 78 is both a tension and torsion spring in its functioning. The exten-

sion of the spring which places it under a tensile load is achieved by having the rifle rest in the hook 70. Therefore when the rifle is lifted from the hook the spring, by its inherent resiliency, returns the shank to which hook 40 is attached thereby lifting pin 62 from slot 58. In addition since the spring 78 is under a torsion load, this load being applied by rotating the shank 78 to withdraw hook 40 from its recess 64, releasing the latch permits the potential energy stored in the spring 78 to rotate shank 38 to a position flush with regard to support 24.

In use the hunter manually pulls the hook from recess 64 and places his gun, for example rifle 20, thereon. The weight of the gun pulls pin 62 into the slot 58 thereby locking the hook in such position that it is approximately perpendicular to the support 24. If the rifle is placed with its center of gravity approximately positioned over the hook of the rifle carrier, the rifle will be balanced on the hook and make it extremely easy to carry and handle by the hunter. The rifle may be carried higher or lower on the hunter or at an angle which he desires for his personal convenience. When the hunter is ready to use the rifle, even at an instant's notice, he lifts the rifle from the hook and due to its position alongside of the hunter, it is in readiment for immediate action. However, the instant that the rifle is removed from the hook, the spring 78 lifts the hook and rotates it thereby returning it to its recess in the support 24. It cannot act as an obstruction to the hunter in this position and he is free to use his rifle in any way that he chooses.

The foregoing is considered as illustrative only of the principles of the invention. Further, since numerous modifications and changes will readily occur to those skilled in the art, it is not desired to limit the invention to the exact construction and operation shown and described, and accordingly, all suitable modifications and equivalents may be resorted to, falling within the scope of the invention as claimed.

What is claimed as new is as follows:

1. A gun carrier comprising a body strap, a gun cradle, a support for said cradle carried by said body strap, resilient means for pressing said cradle against said support, a latch releasably retaining said cradle in one position, said support including a panel provided with a recess in which to accommodate said cradle when it is pressed by said resilient means against said support.

2. A rifle carrier for a hunter which includes a body strap and a support attached to the body strap, said support having an outer surface, a cradle for the rifle and including a shank, means mounting said shank on said support for rotation so that said cradle may be rotated to a rest position superposed and flush with said support surface and said cradle may be rotated to a rifle supporting position which is approximately normal to the surface of said support.

3. A rifle carrier for a hunter which includes a body strap and a support attached to the body strap, said support having an outer surface, a cradle for the rifle and including a shank, means mounting said shank on said sup-

port for rotation so that said cradle may be rotated to a rest position superposed and flush with said support surface and said cradle may be rotated to a rifle supporting position which is approximately normal to said surface of the support, said mounting means including a sleeve in which a portion of said shank is mounted for rotation, and yielding means attached to said sleeve and said shank constantly biasing said shank so that said cradle is in said rest position.

4. A rifle carrier for a hunter, said carrier including a body strap and a support attached to the body strap, a cradle for the rifle and including a shank, means mounting said shank on said support for rotation so that said cradle may be rotated to a rest position superposed with respect to said support and said cradle may be rotated to a rifle supporting position which is approximately normal to said support, said mounting means including a sleeve in which a portion of said shank is mounted for rotation, yielding means attached to said sleeve and said shank constantly biasing said shank so that said cradle is in said rest position, and a latch operatively connected with said shank and said sleeve in order to hold said shank in a releasably latched position to support the rifle.

5. The rifle carrier of claim 3 wherein said support includes a panel, a housing connected with said panel, and said sleeve and a portion of said shank being disposed in said housing.

6. The rifle carrier of claim 3 wherein said support has an outwardly opening recess in which to accommodate said cradle.

7. The rifle carrier of claim 3 wherein one end of said cradle has a smoothly contoured surface functioning as a guide over which the trigger guard of the rifle passes when being removed from said cradle.

8. In a rifle carrier which has a support, a rifle cradle, means mounting said cradle on said support for rotation from a rest position to a rifle supporting position, means connected to said cradle for releasably holding said cradle in the rifle supporting position, said cradle having an end provided with opposite sides, one of said sides being curved towards one of the side edges of the support when the cradle is in the rifle supporting position to provide a guide surface over which a portion of the rifle is slidable when removing the rifle from said cradle, said support having a recess in which to accommodate said cradle when in the rest position, and means for urging said cradle into said recess.

References Cited in the file of this patent

UNITED STATES PATENTS

475,640	Unger	May 24, 1892
1,533,661	Remillong	Apr. 14, 1925
1,651,969	Saxton	Dec. 6, 1927
2,423,531	Theis	July 8, 1947
2,526,768	Pendergrass	Oct. 24, 1950
2,536,252	Bates	Jan. 2, 1951
2,637,474	Di Vincenzo	May 5, 1953