



US 20050099279A1

(19) **United States**

(12) **Patent Application Publication**
Forbes et al.

(10) **Pub. No.: US 2005/0099279 A1**

(43) **Pub. Date: May 12, 2005**

(54) **VEHICULAR BLACK BOX MONITORING SYSTEM**

(60) Provisional application No. 60/252,537, filed on Nov. 22, 2000.

(76) Inventors: **Fred Forbes**, Tucson, AZ (US); **Scott Forbes**, Tucson, AZ (US); **David Forbes**, Tucson, AZ (US); **James Forbes**, Sierra Vista, AZ (US)

Publication Classification

(51) **Int. Cl.**⁷ **B60Q 1/00**

(52) **U.S. Cl.** **340/435; 348/148**

Correspondence Address:
CISLO & THOMAS, LLP
233 WILSHIRE BLVD
SUITE 900
SANTA MONICA, CA 90401-1211 (US)

(57) **ABSTRACT**

(21) Appl. No.: **11/004,491**

(22) Filed: **Dec. 2, 2004**

Related U.S. Application Data

(62) Division of application No. 09/991,509, filed on Nov. 21, 2001.

A vehicular "black box" provides recording means by which driver action can be reviewed after an accident or collision, as well as indicating immediate vehicle disposition status to the driver. Using cameras (which may be very small), the disposition of the vehicle in its lane is determined by detecting the highway lines painted on the road.

The data is also recorded so that should an accident or collision occur, the events leading up to such an event are made available for later review and analysis.

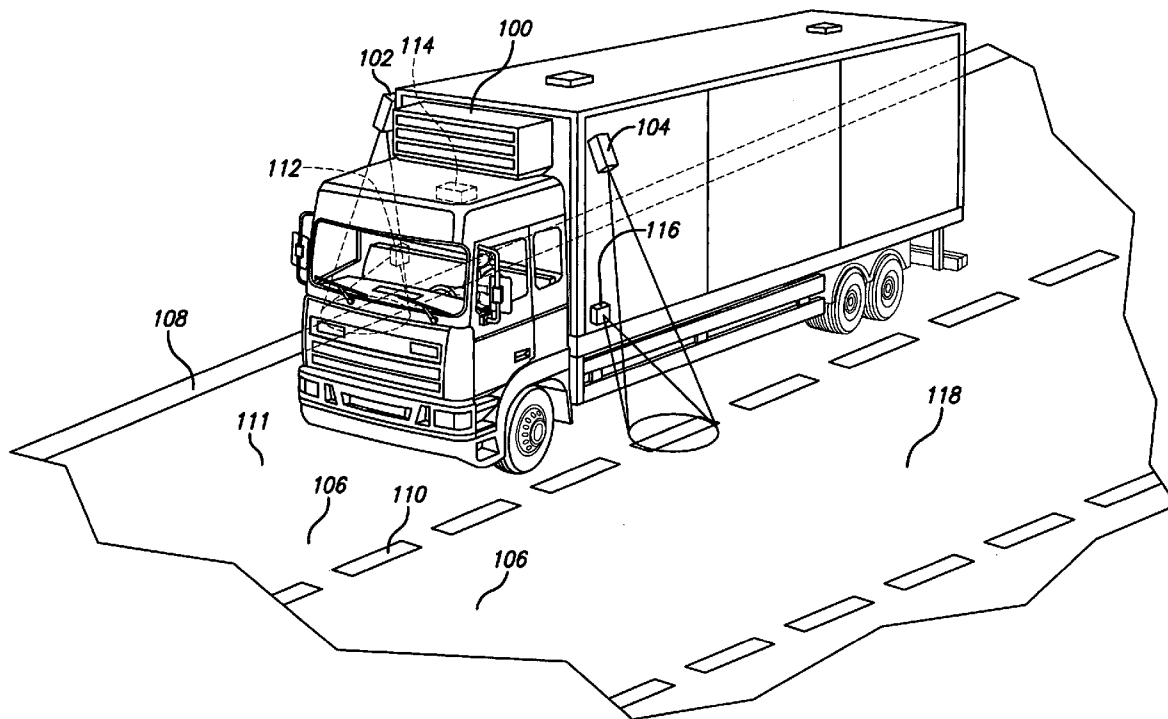

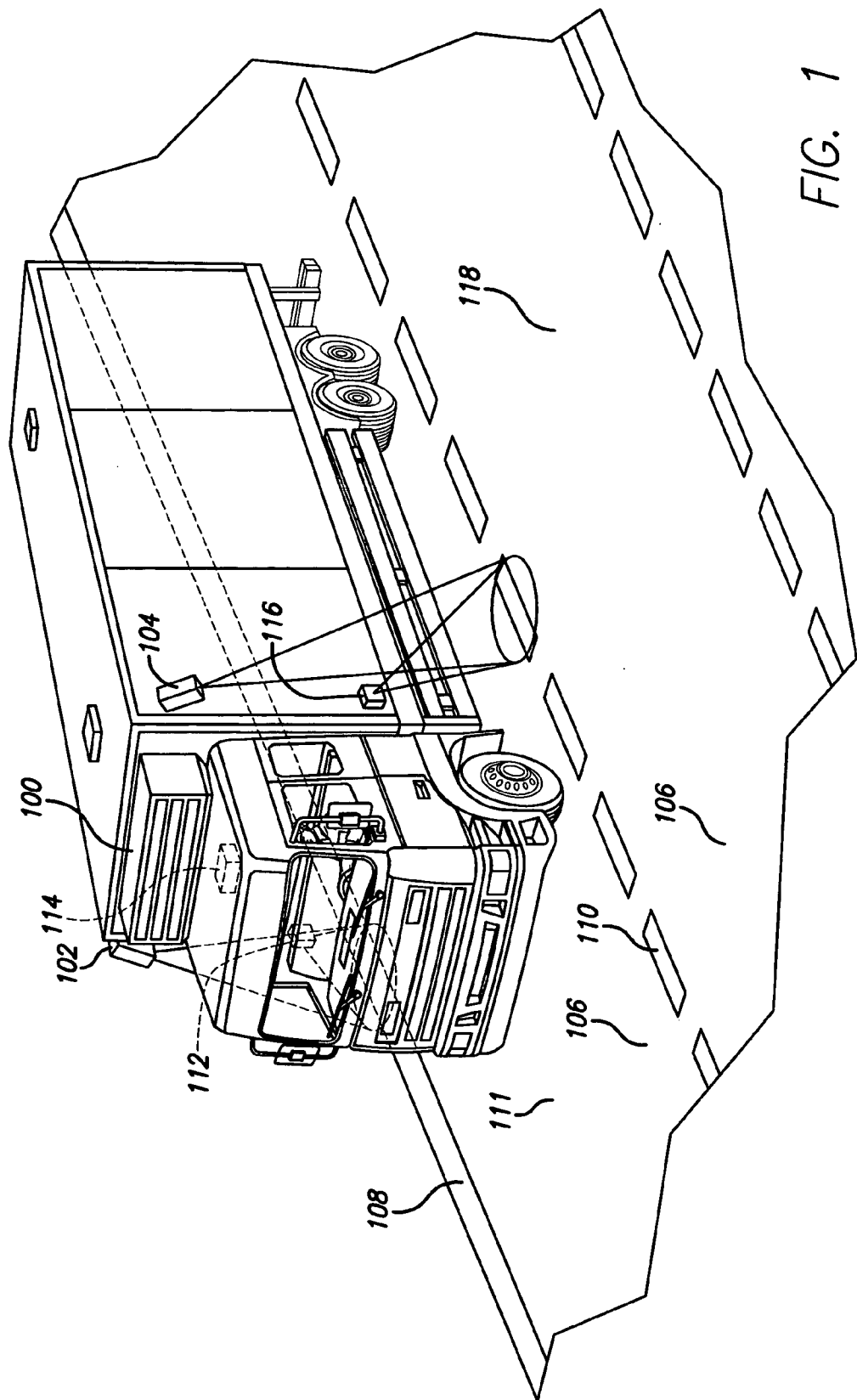

FIG. 1

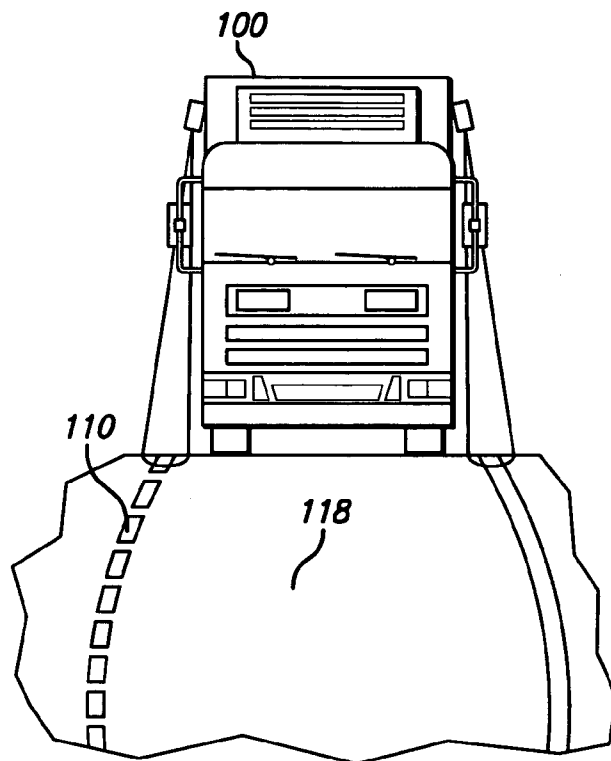

FIG. 2

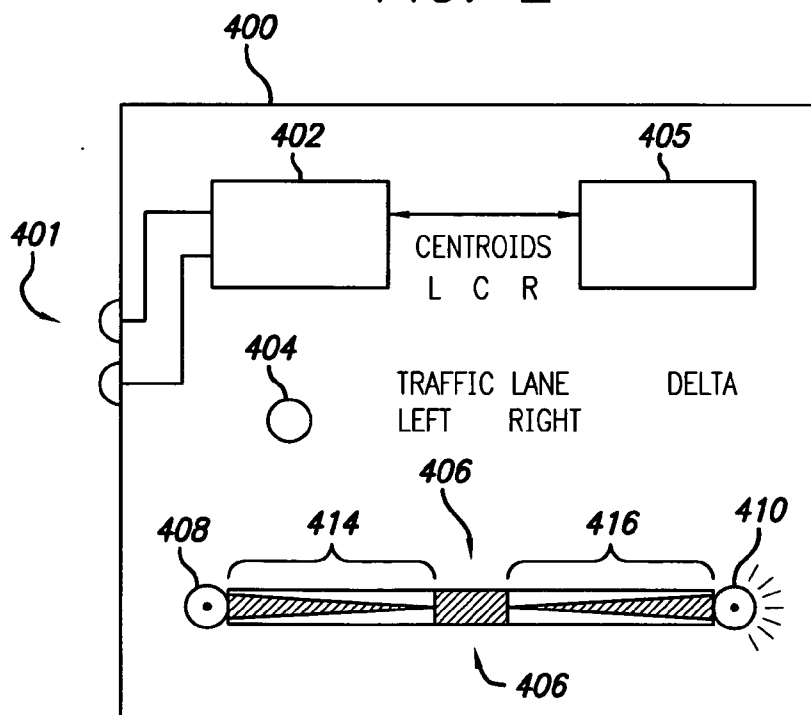
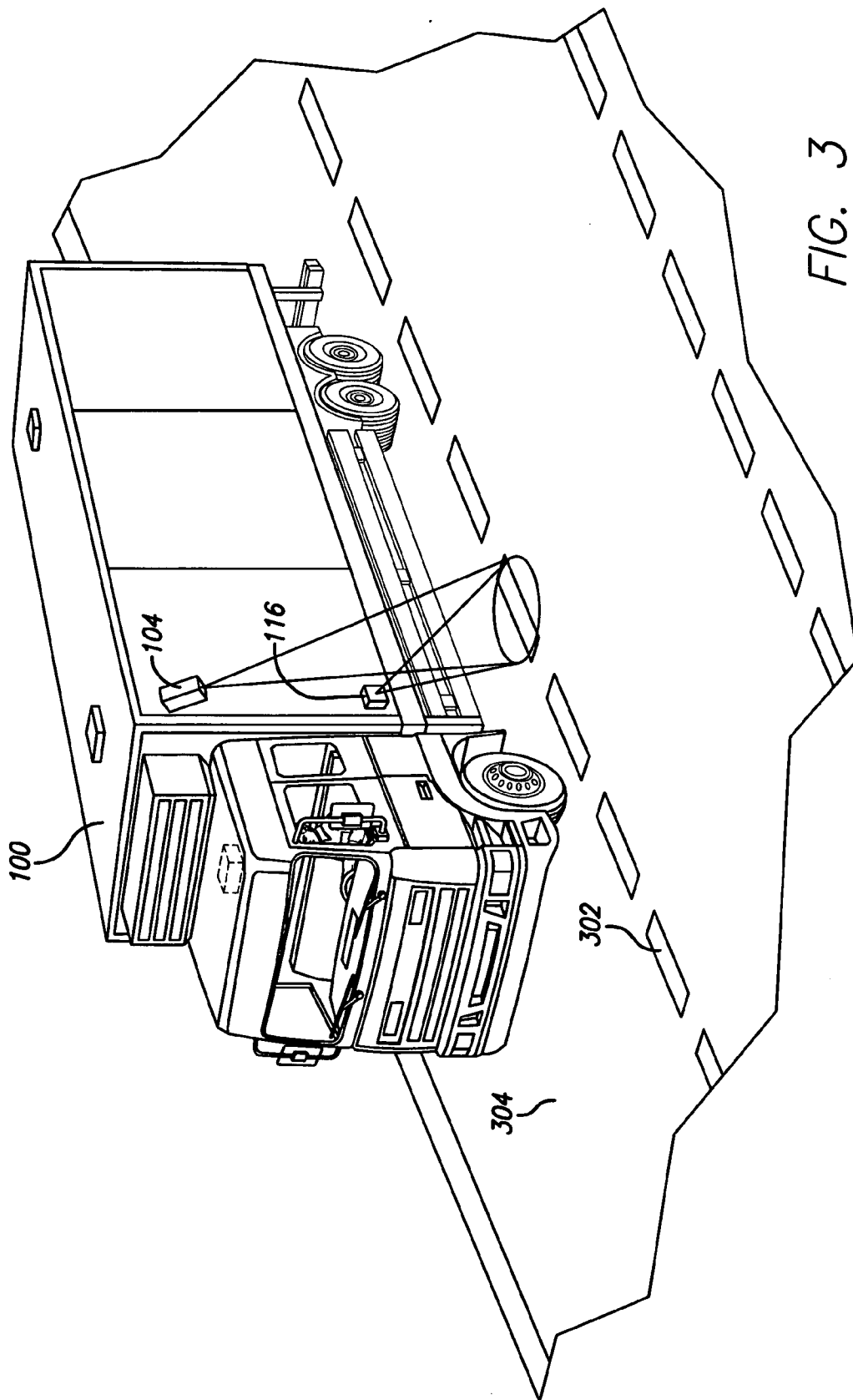

FIG. 4



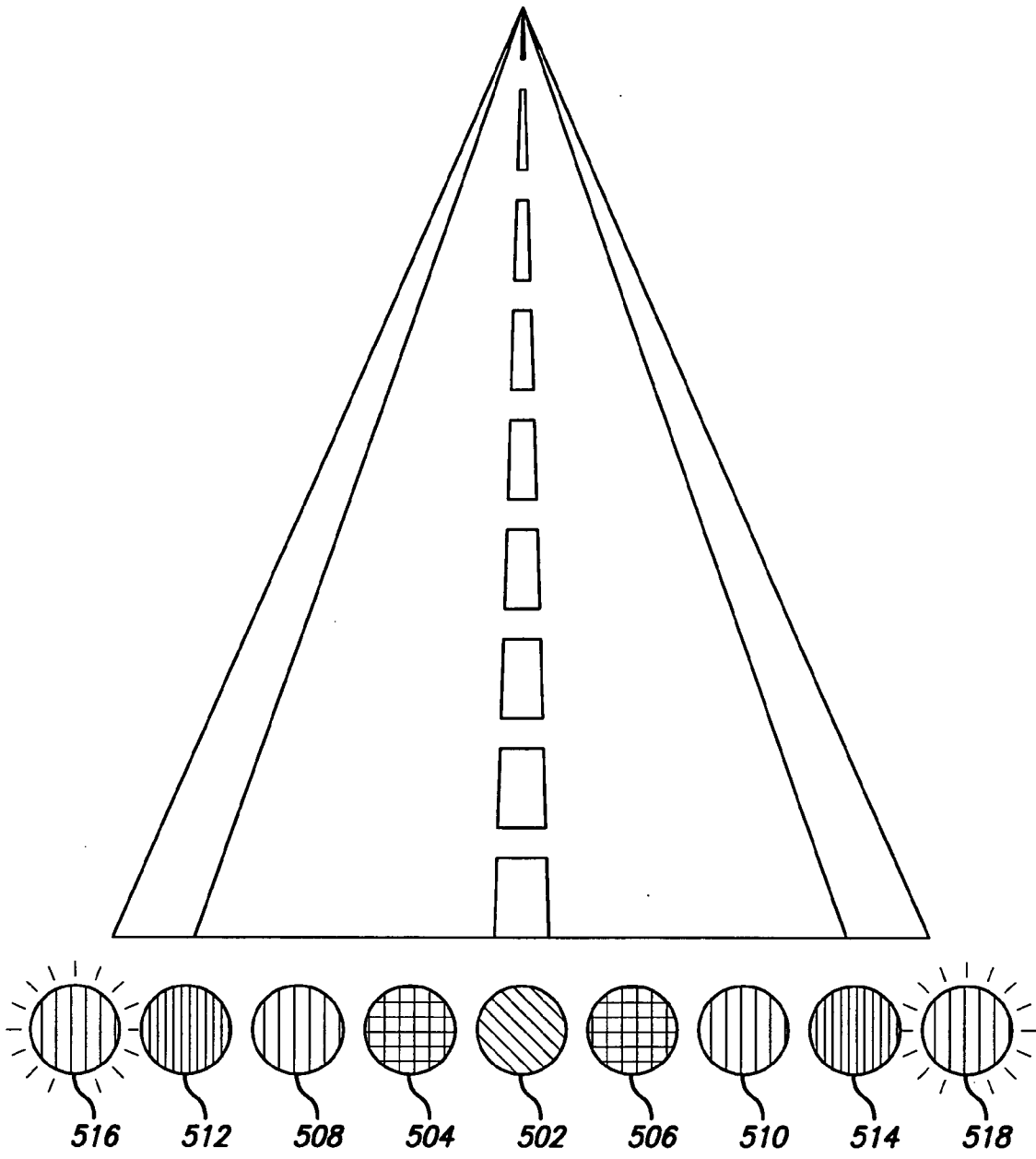
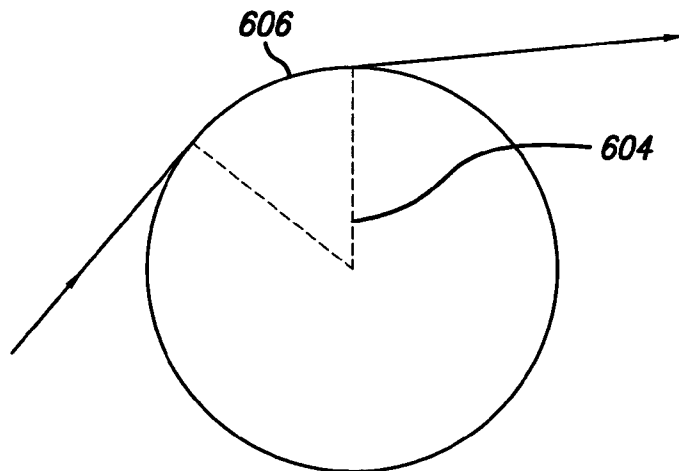
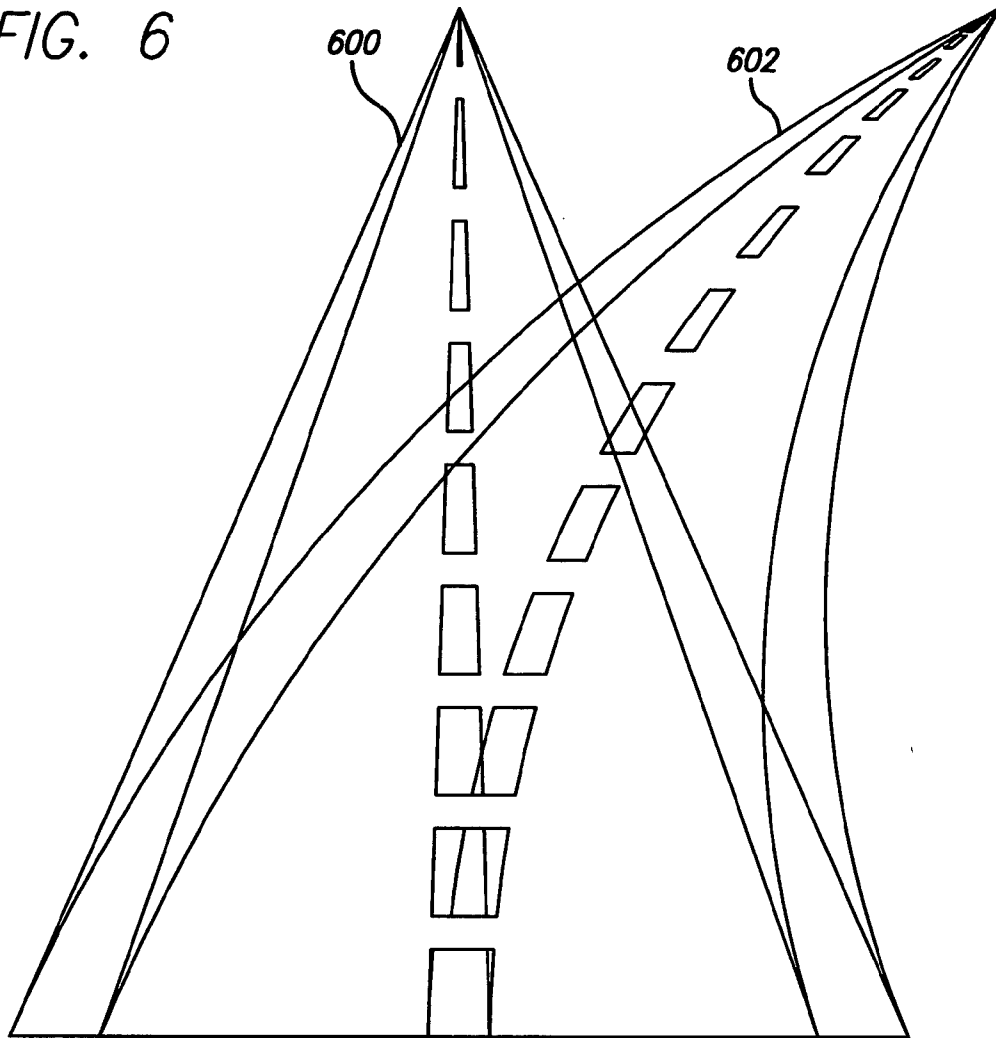

FIG. 5

FIG. 6



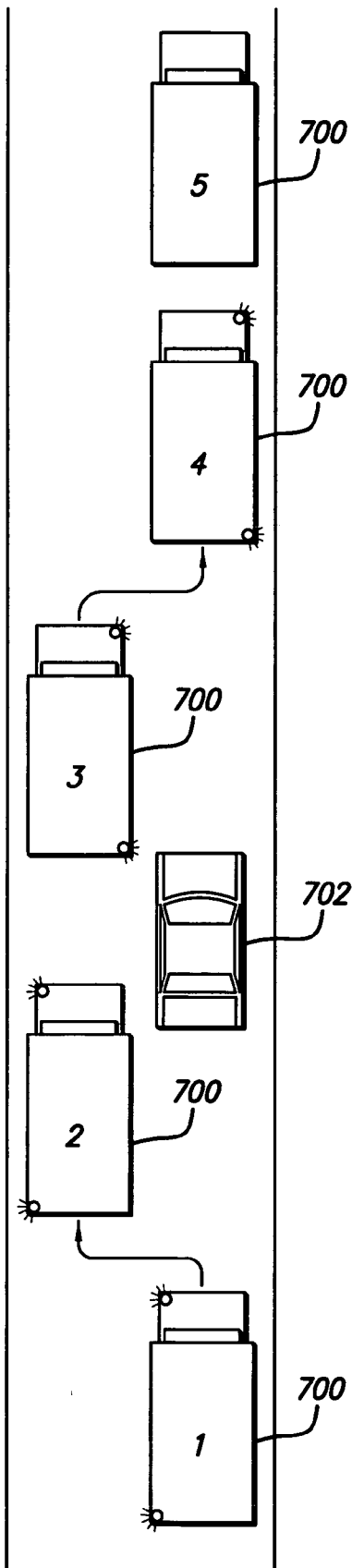

FIG. 7

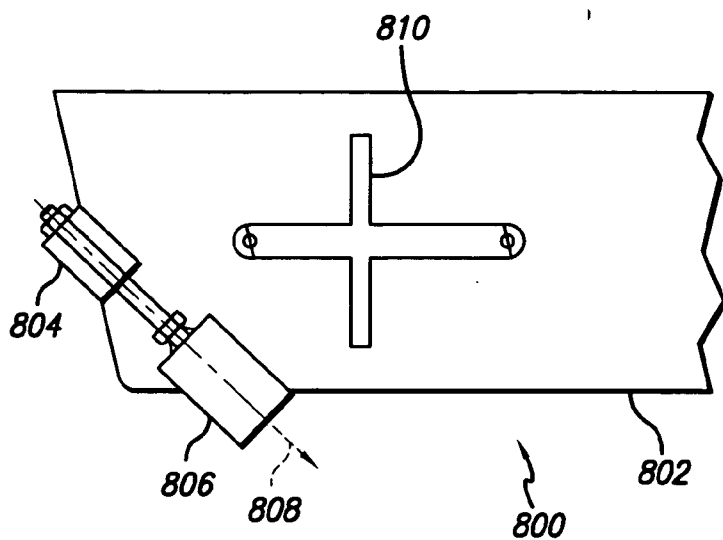

FIG. 8

FIG. 13

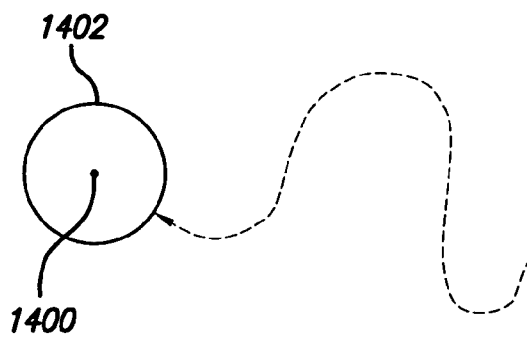
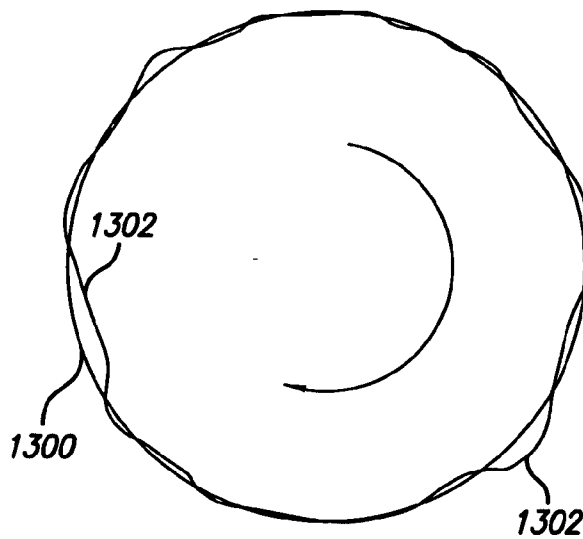

FIG. 14

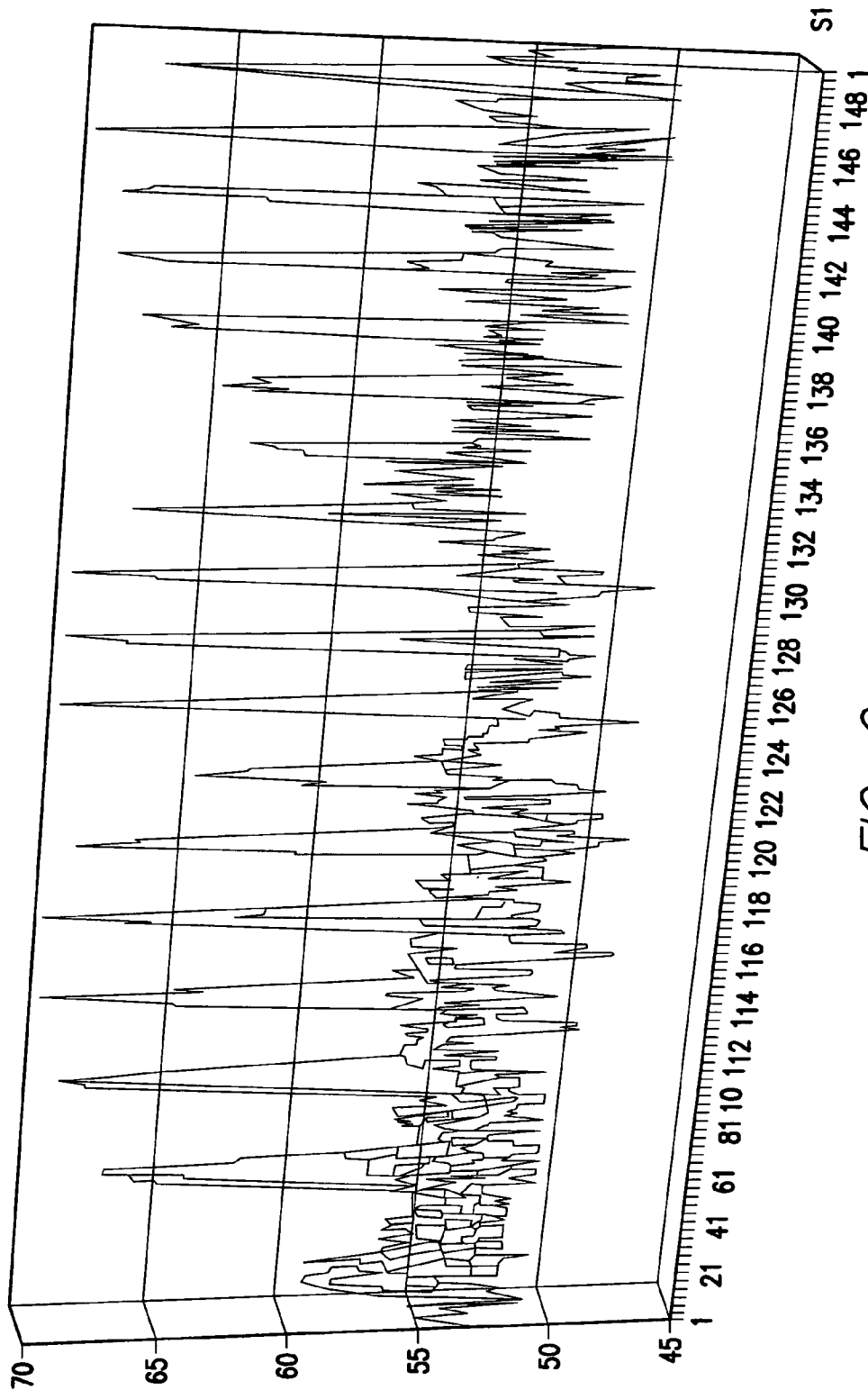

FIG. 9

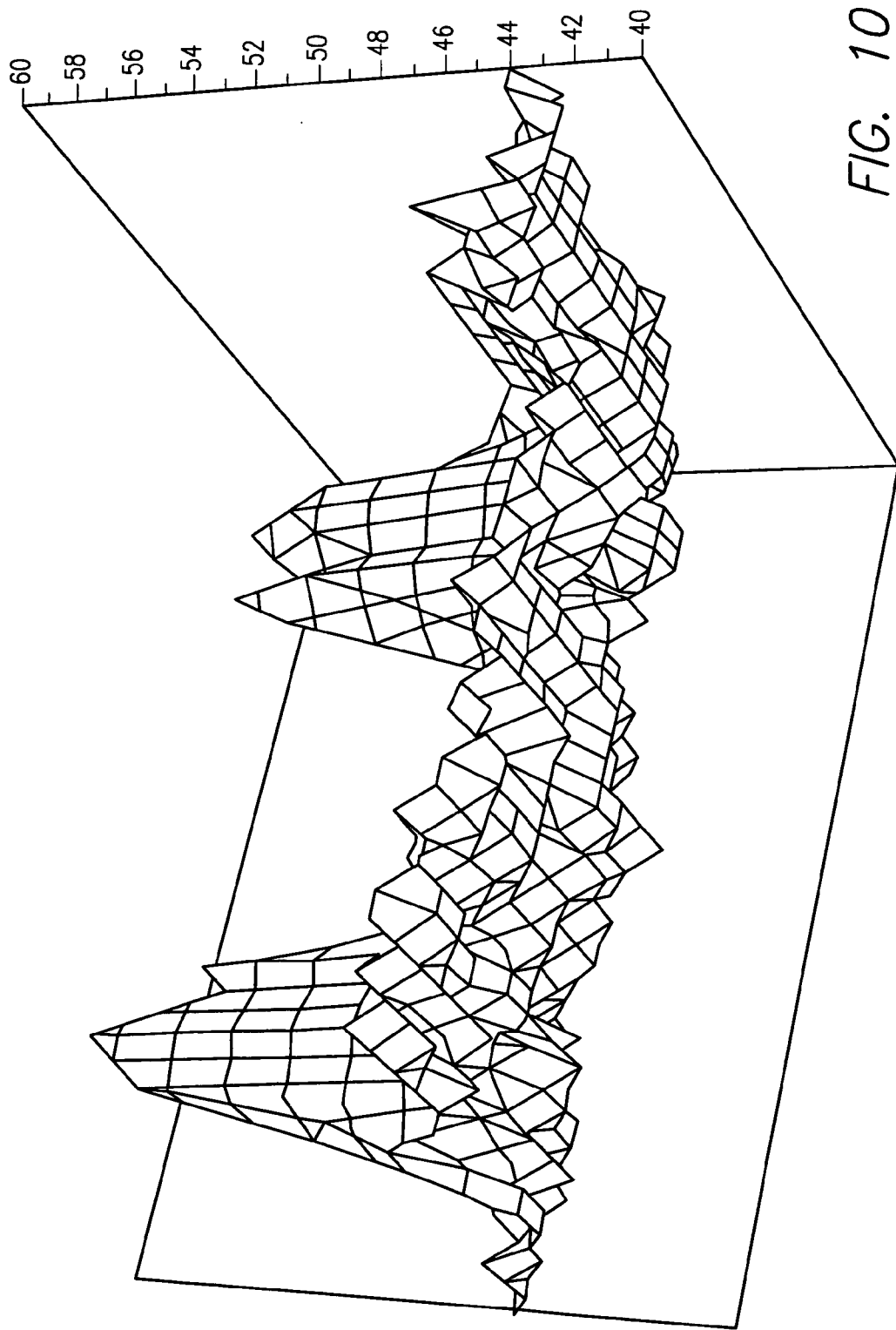

FIG. 10

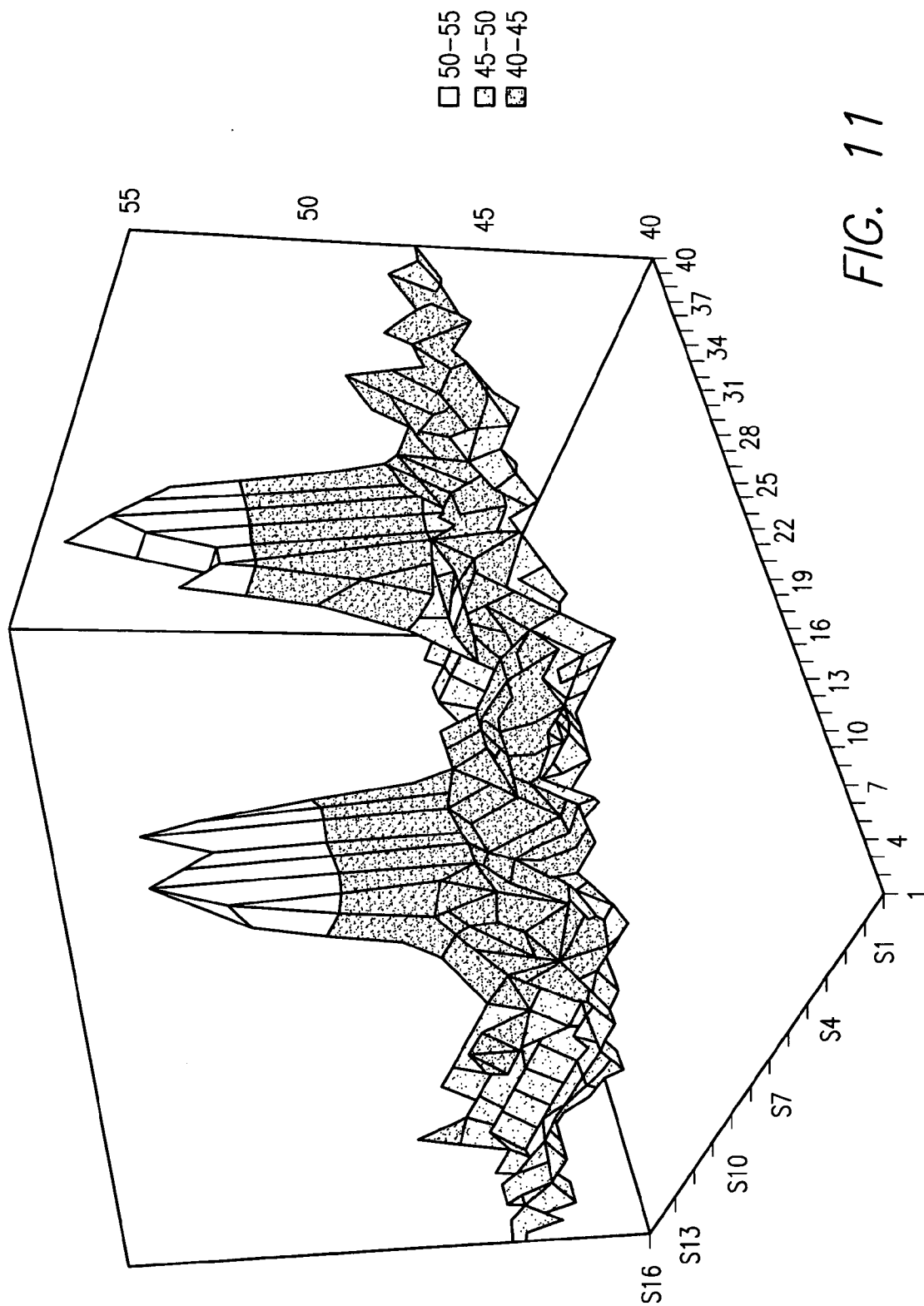

FIG. 11

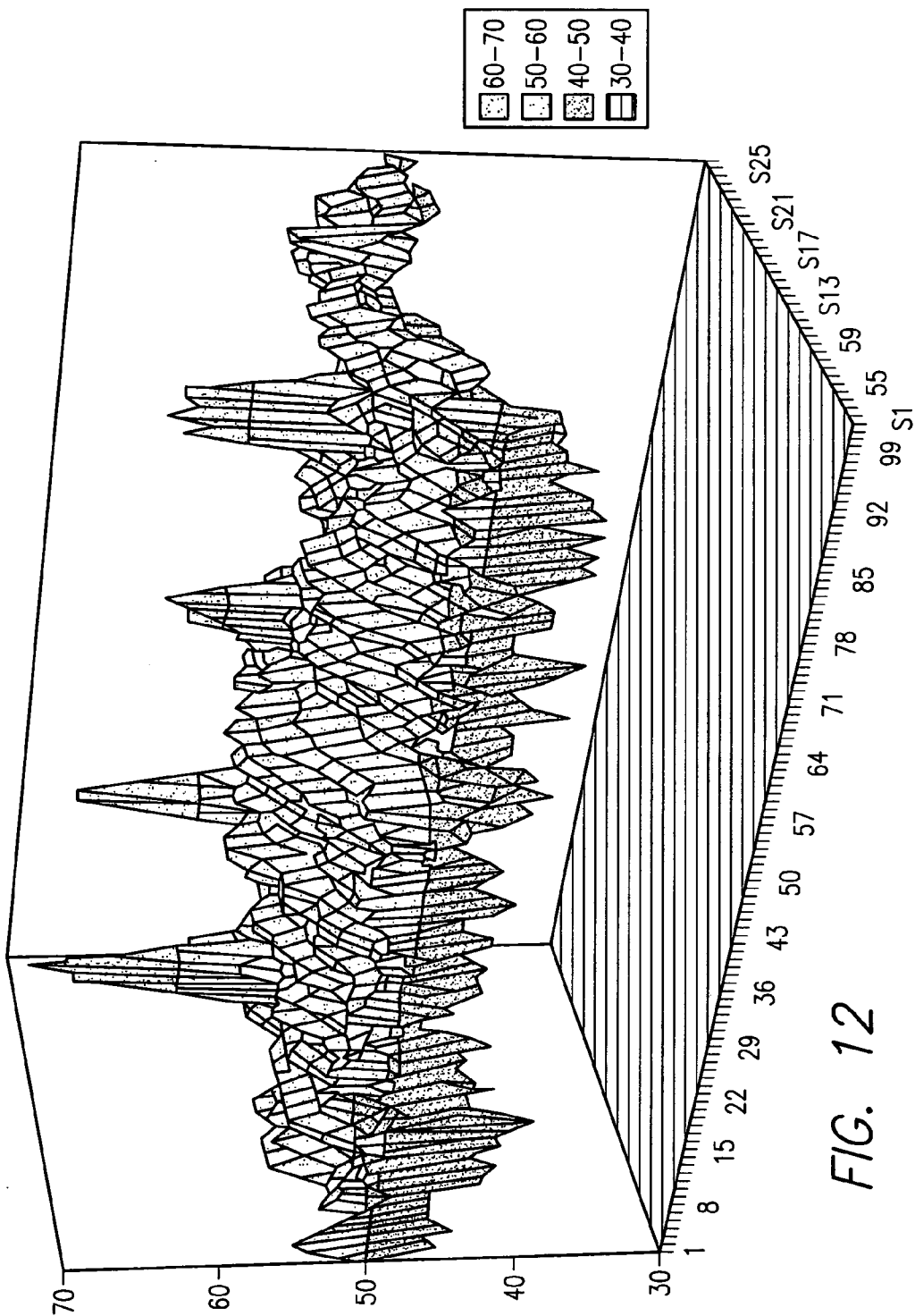

FIG. 12

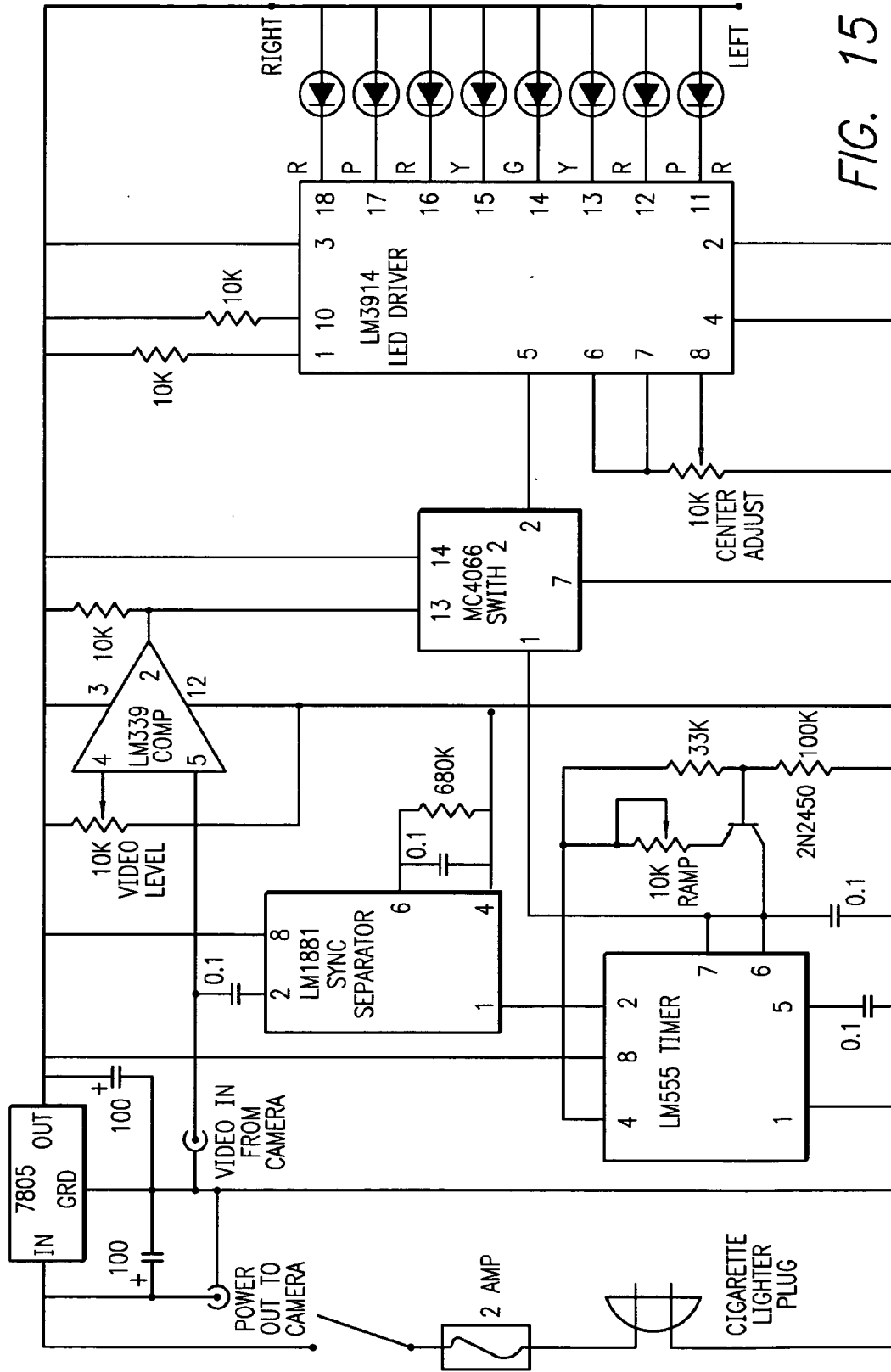

FIG. 15

VEHICULAR BLACK BOX MONITORING SYSTEM

CROSS-REFERENCES TO RELATED APPLICATIONS

[0001] This patent application is a divisional of U.S. patent application Ser. No. 09/991,509 filed Nov. 21, 2001 entitled Vehicular Black Box Monitoring System which is patent application is related to and claims priority from U.S. Provisional Patent Application Ser. No. 60/252,537 filed Nov. 22, 2000 entitled Vehicular Black Box Monitoring System which applications are incorporated herein by this reference thereto.

COPYRIGHT AUTHORIZATION

[0002] Portions of the disclosure of this patent document may contain material which is subject to copyright and/or mask work protection. The copyright and/or mask work owner has no objection to the facsimile reproduction by anyone of the patent document or the patent disclosure, as it appears in the Patent and Trademark Office patent file or records, but otherwise reserves all copyright and/or mask work rights whatsoever.

BACKGROUND OF THE INVENTION

[0003] 1. Field of the Invention

[0004] This invention relates to monitoring and recording systems for transportation systems, and more particularly to a "black box" system for monitoring and recording the activity in a motor vehicle.

[0005] 2. Description of the Related Art

[0006] In order to provide forensic evidence of catastrophic failure of aircraft and the like, recording devices denominated as "black boxes" have been installed in commercial airliners for the past several years. These black boxes are generally of two types: the cockpit voice recorder and a flight data recorder. The cockpit voice recorder records the voices of the pilots and crew in the cockpit area for approximately thirty (30) minutes prior to the catastrophic failure of the aircraft. The flight data recorder records instrument readings and the like. A shared clock or otherwise can allow the coordination of flight data with voice data, such that forensic analysts can re-constitute the events and actions leading up to a catastrophic failure of the aircraft that results from a crash or other failure.

[0007] Such black box devices could also advantageously be used in other vehicles or situations where a catastrophic event requires an analysis of events leading up to it. One such situation is present in long-haul truck driving where truck drivers transport cargo over long distances for long periods of time. One example might be a New York to Los Angeles run, where goods from New York City are acquired in Los Angeles and are transported most efficiently by truck. Due to the competitive nature of the business, drivers are asked or required to drive their rig for as long as possible, so that the shipment might be delivered as soon as possible. This often leads to driver fatigue and drowsiness, sometimes resulting in the failure of the driver to control the rig and, possibly, collisions, accidents, or crashes involving the rig.

[0008] As set forth in Appendix A, the National Highway Transportation Safety Administration (NHTSA) has

addressed the issue of driver fatigue in a report regarding "Drowsy Driving and Automobile Crashes." The enclosed report is incorporated herein by this reference thereto. Not only do long-haul truck drivers experience fatigue and drowsiness, but also drivers of other vehicles as well, with there being certain groups or categories of individuals being more susceptible to such risks than others.

[0009] Because such sleepiness, drowsiness, and/or fatigue can lead to difficulties, and because technology may be available along the lines of those used in aircraft for recording events leading up to a vehicle failure or the like, it would be advantageous to provide a means by which both the driver can be alerted as to his/her drowsy condition in order to accommodate it, as well as a record of the events leading up to any crash or collision resulting from drowsiness. As set forth in more detail below, the present invention addresses these and other concerns.

SUMMARY OF THE INVENTION

[0010] The present invention provides a vehicular monitoring system in the form of a black box or the like that uses signals generated from video input in order to determine the disposition of the vehicle on the roadway. By determining such vehicle disposition, the activity of the driver can then be monitored. In the event of a collision, crash, or if the vehicle drives off the road, the recording made by the vehicular black box of the present invention can then be used to evaluate and analyze the course of events preceding the crash or the like.

[0011] Generally, two video cameras are used in order to determine the highway lane through which the vehicle is traveling (although it may be possible to use any number of cameras). For a solid line, a continuous signal is given. For a broken line, an intermittent signal is given. In conjunction with association with a turn signal, the present invention can evaluate the driver's performance in keeping the vehicle on the roadway and alert the driver when the vehicle is not properly disposed in its lane.

[0012] Additionally, accuracy tests that indicate the mental, visual, and manual acuity of a driver are also disclosed herein and serve to provide an indication of future driving performance as generally the same skills needed to properly drive an automobile, a bus, a large truck or rig, or other motor vehicle as are needed to perform well on such tests.

[0013] The system may be implemented for monitoring drivers associated with public safety concerns such as truck drivers and drivers with DUI records, sleep attack disorders and the like.

OBJECTS OF THE INVENTION

[0014] It is an object of the present invention to provide a warning system for driver drowsiness and the like.

[0015] It is yet another object of the present invention to provide a vehicular black box that allows reconstruction of an accident by providing a record of events prior to the occurrence of an accident.

[0016] It is yet another object of the present invention to provide a combination driver-drowsiness system as well as a vehicular black box in order to promote better driving and fewer accidents on the highways.

[0017] It is yet another object of the present invention to provide a system for rating a driver's performance based on a numeric scale characterizing a vehicle driver profile or signature based on his/her lane tracking ability.

[0018] These and other objects and advantages of the present invention will be apparent from a review of the following specification and accompanying drawings.

BRIEF DESCRIPTION OF THE DRAWINGS

[0019] **FIG. 1** is a general schematic depiction of the vehicular black box system of the present invention, showing a vehicle and driver travelling down a roadway towards the viewer.

[0020] **FIG. 2** is a front plan and schematic view of the vehicular black box system of the present invention showing the vehicle in the passing lane.

[0021] **FIG. 3** is a front left perspective view of the vehicular black box system of the present invention as attached to a large vehicle.

[0022] **FIG. 4** is a schematic representation of elements composing or comprising the vehicular black box of the present invention.

[0023] **FIG. 5** shows a schematic representation of a roadway accompanied with indicator signals that may be associated with the vehicular black box of the present invention.

[0024] **FIG. 6** shows a comparative depiction of curved and straight roadways for engagement by the vehicular black box of the present invention.

[0025] **FIG. 7** shows a schematic representation (scenario) of one vehicle passing another, implementing the present invention.

[0026] **FIG. 8** is a sectional view of a camera mounting within the housing of the side view mirror.

[0027] **FIGS. 9-12** are charts depicting signals arising from the detection of roadway markers, such as stripes or painted lines.

[0028] **FIG. 9** is a chart showing the regular and intermittent detection of dashed lines on a roadway.

[0029] **FIG. 10** is an enlargement of a portion of **FIG. 9** showing contrast of reflected light.

[0030] **FIG. 11** is an enlargement of a portion of **FIG. 9**.

[0031] **FIG. 12** is an enlargement of a portion of **FIG. 9**.

[0032] **FIG. 13** is a depiction of a test and results used in the present invention, where an individual attempts to trace out a circle using a mouse or other device driving a cursor on a computer screen.

[0033] **FIG. 14** shows a depiction of a test to determine response time and accuracy, where the individual attempts to follow a spot on the screen with a mouse driving a cursor.

[0034] **FIG. 8** is a schematic diagram for an electronic circuit for the lane position status indicator of **FIG. 5**.

BRIEF DESCRIPTION OF THE APPENDICES

[0035] The following appendices are incorporated herein by this reference thereto.

[0036] Appendix A is a National Highway Transportation Safety Administration (NHTSA) Report.

DESCRIPTION OF THE PREFERRED EMBODIMENT(S)

[0037] The detailed description set forth below in connection with the appended drawings is intended as a description of presently preferred embodiments of the invention and is not intended to represent the only forms in which the present invention may be constructed and/or utilized. The description sets forth the functions and the sequence of steps for constructing and operating the invention in connection with the illustrated embodiments. However, it is to be understood that the same or equivalent functions and sequences may be accomplished by different embodiments that are also intended to be encompassed within the spirit and scope of the invention.

[0038] **FIG. 1** shows a front plan view and perspective of a truck, rig, bus, or other vehicle **100** incorporating the vehicular black box system of the present invention. As shown in **FIG. 1**, two cameras, **102, 104**, are oppositely opposed on either side of the vehicle. Both cameras **102, 104** are preferably at equal distances away from the body of the vehicle. Typically, lanes are marked in America's interstate highway system by dashed or solid white or yellow lines. The cameras **102, 104** look down to the roadway **106** in order to detect the right shoulder white line **108** and the center dashed line **110**.

[0039] The cameras may be mounted at any convenient location for looking down at the roadway, such as on the body of the vehicle or in the side view mirror attachments or housings, which are located on the doors or side of the vehicle. The cameras may be attached to the vehicle by any convenient means including bolting, welding, and adhesion.

[0040] **FIG. 8** illustrates one example of a camera mounting **800** within the housing of the side view mirror **802**. A mounting cylinder **804** is inserted through a hollowed out portion of the housing **802** as shown in the figure. The camera **806** is bolted to the mounting cylinder, and likewise is inserted through a hollowed out portion of the housing **802**. The camera **806** is positioned to look downward at the road as indicated by the dashed arrow **808** preferably at an angle of approximately 45° with respect to the road. The vehicle itself, not shown in the figure, is located to the left of the housing. Additionally, the cross bar **810** shown in the figure is part of the mounting for the mirror.

[0041] Going back to **FIG. 1**, the camera, **102**, on the right side of the vehicle seeks to detect the line **108** on the right shoulder. The camera **104** on the left side of the vehicle seeks to detect the center dashed line **110**. For a vehicles such as a truck, each camera is preferably at a distance of approximately 11 feet from the highway surface.

[0042] As shown in **FIG. 1**, the vehicle travels in the right lane **111** of the four-lane highway divided in two lanes going in opposite directions. As set forth in more detail below, the black box of the present invention is not limited to use when the vehicle is travelling in the right highway lane.

[0043] Additionally, as shown in **FIG. 1**, the right shoulder white line **108** may be illuminated by a right shoulder light **112** so that the right camera **102** may better pick up the white line **108** of the right shoulder. In one embodiment, the

light, **112**, may be a regular light focused upon the white line of the right shoulder, illuminating a circle of approximately 2 feet in diameter centered at the camera field. Additionally, the light **112** may be tuned to a special frequency of light (e.g., infrared) that might be available through a light source such as a laser, light emitting diode, or the like. A condensing lens may be used to spread out the image. The right camera **102** may then pick up specifically reflected light by the right shoulder line **108** (of white or any other color) that is unique to the frequency of the laser light. In this way, other sources of illumination will be ignored, and the camera can focus specifically upon light reflected upon reflective or other material imbedded or incorporated into the paint of the right shoulder line **108**.

[0044] The camera **102** may be a CCD (Charge Coupled Device) that is extremely sensitive while being very small, preferably in the order of an inch and a half square and requiring very little power. Consequently, it is generally easy to fit cameras onto the vehicle such as an 18-wheel, big rig, or the like. The camera **102** is connected to a central control or recording device **114** termed "black box."

[0045] The left-side camera **104**, which is displaced horizontally on the other, or left side of the vehicle, functions similarly to the right side camera **102**. A center dashed line light **116**, may operate in a manner similar to that as the right side light **112** for the camera **102**. The left light **116** operates for the left camera **104**, while the right side light **112** operates for the right camera **102**. The lights may be mounted at any convenient location for operating with the cameras.

[0046] Consequently, it can be seen that despite varying external conditions, cameras **102** and **104** are able to pick up the highway lines and use them as indicators of the vehicle's disposition between them.

[0047] FIG. 2 shows a front schematic view of the vehicle **100** of FIG. 1 when it is in the passing lane **118**. When in the passing lane, the vehicle has a dashed white center line **110** on its right and a generally solid yellow line on its left. The right camera **102** then picks up the dashed center line, while the left camera **104** picks up the solid left shoulder line.

[0048] For travel in either a traveling lane, a passing lane, or a lane between (where the lines on both sides of the vehicle are dashed), the right camera **102** and left camera **104** pick up the video signals from the lines (converting them to electrical signals) from which the travel of the vehicle in the lane can be determined. Any variance, drifting, swerving, or the like in the lane is detected by the cameras and recorded by the black box. By inspection of the signals from the cameras, the travel of the vehicle along the roadway can be determined.

[0049] FIG. 3 shows an alternative embodiment of the camera configuration of the present invention. The left camera **104** is mounted along the side of the vehicle **100** so as to pick up the travel of the line on the left-hand side of the vehicle. In the case of FIG. 3, the illuminated lines picked up by the camera are the dashed center lines **302** as the vehicle is travelling in the right-most lane **304** of the roadway.

[0050] By detecting the presence and location of the highway lines on either side of a lane, the system can

determine the magnitude of deviation of the vehicle from the center of the lane. Determination of the centroids of the signals received from the camera serves as an indication of the presence and relative position of the line. The magnitude of deviation from the center can be based on the detection of how far the vehicle is from the highway lines on each side of the vehicle. For a vehicle traveling exactly in the center of the lane, the distance between the vehicle and the highway lines on either side of the vehicle should be equal. Additionally, a driver may determine his ideal position in the lane and set the system to zero at that position, thereafter, any detected deviation away from the set position will be indicated to the driver. Alternatively, the system may detect and indicate to the driver any change from a previous position relative to the lane, without having a point of reference indicating an ideal position. An indication that the driver is constantly or erratically changing positions relative to the lane (say approximately every 2 seconds) may serve to indicate that the driver is weaving.

[0051] Although two cameras have been illustrated in the above figures, any number of cameras may be used. For a system having one camera, the driver's position within a lane may be monitored by detecting the position of the highway line within the field of view of the camera by determining the centroids of the signals received. For a vehicle traveling in a straight path within a straight highway lane, the position of the highway line should be unchanging within the camera's field of view as described above. Any deviation from a given position indicates that the vehicle is swerving or otherwise not traveling in a straight line. Additionally, the driver may zero the system when he perceives his position in the lane to be the ideal position. Thereafter, the system would indicate any deviation from that position using one camera.

[0052] In order to enhance the video pick up of the dashed lines, especially at nighttime, a source of illumination or the like may be used to shine light upon the roadway, particularly the area through which the dashed lines travel as the truck or vehicle travels along the roadway. Per the above, the camera may be tuned to receive light particular to the source of illumination so as to ensure the appropriate detection of the dashed lines as they travel past the vehicle. When the vehicle is in the left-most lane, the yellow continuous highway line may be picked up and detected by the camera.

[0053] FIG. 4 shows one embodiment of the present invention, where camera signal inputs are fit into a self contained black box **400**, indicated by the arrow **401**. The black box **400** includes a CK CPU **402** having a reset button **404**. The CK CPU **402** is associated with a memory element **405**, particularly the RAM memory, which may be remotely interrogated, and executes program steps upon the data in order to derive centroids. The centroids may indicate that the vehicle is left in a position where it should be, appropriately centered, or right at the position where it should be in the lane (L C R in FIG. 4). The computer may be a commercial computer equipped with a fast (e.g., 30 HZ) frame grabber having software to compute road line profile centroid strings which are processed and analyzed to determine vehicle lane observance and to alert the driver if the vehicle is in danger of unintentionally departing the lane.

[0054] A traffic lane indicator (left, right) is shown in FIG. 4 and may be used in conjunction with the turn signal or the

like to indicate the lane in which the black box currently “sees” the vehicle. Additionally, a delta or adjustment function may be provided so as to allow for adjustment of the black box, where for any reason, an adjustment needs to be made for indicating the center position in a lane. A reset button allows the system to reset to a default configuration.

[0055] A display panel associated with the black box 400 has a lane position status indicator, 406, shown towards the bottom of FIG. 4 as generally an analog indicator, allowing the driver to monitor the position of the vehicle as perceived by the black box. At the extreme left, an alert 408 is given to the driver to indicate that he is drifting too far left. The same is true at the opposite end of the status indicator, where an alert 410 is given when a driver drifts too far right. A center lane 412 or proper disposition indicator is shown in the center of the status indicator. Between the center lane indicator and the far left alert, a “drifting left” 414 indication is given. Similarly, a “drifting right” 416 alert is given when the vehicle is departing from the center and going towards the right. The drifting left and drifting right indications provide means by which the driver can be alerted to the status before an alert is given. The center lane, drifting left or drifting right indications may be displayed by lights which illuminate a portion of the display corresponding to the position of the vehicle within the lane.

[0056] FIG. 5 shows an alternative embodiment of a lane position status indicator 500, showing a schematic view that disappears into the vanishing point of approximately 310 feet delivering approximately a seven degree (7°) angle for two lanes of a four-lane highway.

[0057] When the vehicle is centered in the lane, a green light 502 goes on. Should it depart left or right (the area for which the green light shines, initially), a yellow light (504 or 506) comes on to alert the driver of his or her departure from the appropriate center line. After the yellow lights activate, a red light (508 or 510) come on, then pink (512 or 514), and then flashing red (516 or 518). All of these are shown in FIG. 5 and enable the black box of the present invention to provide not only a record of such departure from the center of the lane, but also an indication to the driver that such a departure is occurring. FIG. 15 is a schematic diagram for an electronic circuit for the lane position status indicator 500. The elements of the circuit are labeled in the figure.

[0058] A sound alarm may accompany the flashing red light in order to alert the driver of his/her potentially hazardous driving. This will serve to awaken a driver who has fallen asleep at the wheel. Such alarm may be turned off by the push of a button or may automatically taper off as the vehicle position is corrected to the lane center. The alarm may further be activated by the push of a button to test if it is properly operating. Features which allow the driver to set the alarm volume and select a certain type of alarm sound may also be provided. An adjustable threshold may also be set by the driver to establish the level of centroid error to activate the audible alarm system.

[0059] Before the alarm goes off, other milder warning signals, besides the light signals may be sounded such as a recorded voice warning when a driver is close to the flashing red zone. Various types of alarms and warning signals may be used, such as for example, the vibration of the wheel or seat, the activation of the vehicle air condition, heater, or fan, the automatic opening of the window, automatic activation

of the radio, the release of a mist spray or perfume scent, or the sounding of a buzzer or car horn. Such alarm or warning signals may be scrambled so as to randomize agitation.

[0060] Additionally, the alarm may be programmed to go off after a predetermined time period, say 20 seconds, in which the vehicle is detected as deviating from the lane center at a specified threshold value. Other possible indications for activating the alarm may be the absence of movement of the steering wheel for a specified time period (e.g., 20 seconds), erratic steering, detection that the car is on the rumble bars or road grooves on the left or right shoulders, or long term pattern of steering errors which may indicate that the driver is drowsy. Detection of the rumble bars on the road may also provide a back up warning system should the lane status indication system fail. The warning alarm system may also have a multiplicative feature such that multiple errors are weighted exponentially, rather than on an additive basis.

[0061] The cameras and black box system may be on standby mode, and ready to operate once the vehicle is in forward gear. Furthermore, the black box may go into a high speed data logging mode when a dangerous situation is detected, to create a more accurate record of the driving in case an accident were to occur.

[0062] The system may include other features such as a status button which allows the driver to bring up his record for review, or to display notes and messages sent from the company headquarters.

[0063] FIG. 6 shows a vanishing point diagram for both straight roads 600 and curved roads 602. For curved roads, the radius of the curvature 604 for a segment 606 of the road is determined by forming a circle having a curvature according to the portion of the segment as shown in the bottom of FIG. 6. The black box of the present invention helps to determine the centeredness of the vehicle, whether or not the vehicle is travelling on a straight road or a curved road by picking up centroids derived from the painted lines alongside the vehicle.

[0064] According to the present invention, a driver's overall performance based on the driver's lane tracking ability may be rated by monitoring and logging into the black box a driver's deviations from the center of a lane. The system may be set to record the instantaneous deviations from the center, and assign a numeric value to the deviation, which most conveniently is the distance away from the center. The average or RMS (root mean square) value of the deviations from the lane center monitored periodically (e.g., 30 times a second) on an ongoing basis, or over the course of a given trip could be used to assign a numeric value based on a scale for characterizing driver performance. Various methods for characterizing driver performance based on the driver's deviations from the center lane, recorded periodically for a given period of time, or based on other driving errors made, will be apparent to one skilled in the art.

[0065] A black box according to the present invention, is preferably designed to be tamper proof, concealed, weatherproof, and to survive an accident. Additionally, stations for calibrating and interrogating the driver's back box may be provided, and frequent stops at such stations may be made mandatory for certain drivers, for example truck drivers and bus drivers. Such calibration stations may have a simulated

road lane with the lines of the road laid down perfectly for allowing the driver to check the system as well as his own driving abilities to calibrate the system.

[0066] FIG. 7 shows a diagram of a passing scenarios where a first vehicle 700 passes a second slower vehicle 702 on the left of that second slower vehicle. The positions of the passing vehicle 700 are indicated by the positions 1-5 in the figure, wherein the vehicle 700 starts from position 1 and finishes passing at position 5. The left turn signal is turned on at position 1 and 2 as the vehicle enters the passing lane, and the right turn signal is turned on at position 3, 4, and 5 as the vehicle returns to its lane. The black box of the present invention may be coupled to the turn signals of the vehicle, allowing for appropriate compensation of the activities occurring with respect to the detected highway lines as the vehicle passes the second, slower vehicle. As such, deviations from the center of a lane due to the driver making a lane change will not be registered by the system for factoring into the driver performance rating, and the position status indicator will not indicate that the driver is drifting off the center of a lane. Additionally, the system could record data while the driver is passing another vehicle to determine how safely the driver is able to pass, taking into account factors such as the drivers speed and time it takes the driver to return to the traffic lane.

[0067] In one embodiment, the turn signals may indicate to the black box that a lane change is occurring, particularly when the speed of the vehicle stays the same or increases. Generally, vehicle speed is maintained or increased when passing a vehicle. However, very often the vehicle is slowed to a complete stop, or very nearly a complete stop, before engaging the turn signal for a left- or right-hand turn.

[0068] FIGS. 9-12 show graphical output derived from data arising from the detection of the highway lines using a single camera.

[0069] FIG. 9 is a plot of intensity versus time showing the intermittent, but regular, detection of the dashed lines present on the left-hand side of the travelling lane on a highway. The peaks indicate the amount of the line detected by the camera. The plot shows both the basic noise level as well as the market peaks indicating the detection of lines. Change of intensity in the peaks indicates that the driver has deviated from a straight path which is exactly parallel to the highway lines.

[0070] FIGS. 10-12 show the intensity profiles of FIG. 9 in typical 3-D plots for fewer spots.

[0071] Additionally, various test may be designed to characterize the driving profile of a driver, which include determining the driver's response time. Such tests may be given to drivers at interrogation stations or whenever else necessary to determine how well a driver can perform.

[0072] A circle tracker test, shown in FIG. 13, is one example of an accuracy test that may be used to help determine the driver's activity behind the wheel. The circle tracker is a device that displays a circle 1300 on the monitor. The user taking the test is then required to trace the circle using the mouse. Typical tracing lines 1302 are indicated in the figure. RMS error is recorded when the cursor departs from the circle on the screen. A log is kept with a running average of each error and can be used to show the manual

coordination of an individual and his/her ability to accurately trace a circle on a computer screen.

[0073] Another test for characterizing a driver's response time and accuracy is a spot clicking test, shown in FIG. 14. A spot 1400 moves about the screen through a random path, for example, as indicated by the dashed line in the figure, and the individual must place a circle 1402 over the spot using the cursor to navigate the circle. RMS error may be recorded as a function of the speed that the spot moves, and a running average may be kept of the error. Additionally, there are varying speeds which may be set for the moving spot, so that the ability of the driver to track the spot is well tested.

[0074] Alertness tests may also be administered while driving. Such tests might involve responding to a sound command or image projected on the windshield. For example, a screen windshield projection or virtual image may be activated in the driver's field of view on which a number, letter, word, symbol, or symbols are presented momentarily to the driver for identification; or a voice command might request the driver to recite a string of numbers. The driver may then be required to reply verbally to a voice deciphering device, squeeze a switch, interrupt a light beam or otherwise respond indicating his response time by so doing. His input may be logged and he could be informed of the ranking of his response. The screen information may be varied in size, color, orientation, length of projection time, etc., and will be programmed to appear when least expected.

[0075] The above tests, including characterizing the driver's lane tracking abilities according to the present invention provide a way of projecting how likely a driver is to make a driving mistake which can lead to a fatal accident. Additionally, these tests can be used for field sobriety testing, as they are simple to administer.

[0076] The monitoring of drivers can also be used for providing a safe system for drivers with sleep disorders characterized by the rapid onset of sleep called sleep attacks. Such drivers can be observed in a laboratory environment for determining and recording the driver's characteristic brain wave patterns during the transition from wakefulness to sleep. The driver's characteristic brain wave patterns can be stored into a device that monitors the driver's brain waves on the road and sounds an alarm when such pattern that can lead to a sleep attack is detected. A device for monitoring the driver's brain waves can be a band which may be a part of a variety of hats (i.e., cowboy, baseball, visor hats) containing conductive electrodes so placed as to sample the driver's EEG brain wave activity or change thereof. A suitable warning device, calibration system, recording element, and/or a tiny transmitter may be incorporated into the band.

[0077] A number of alternative embodiments of the present invention may be achieved, aiding in the tracking, detection, auditing and/or monitoring of the vehicle's travel, particularly across the United States or otherwise.

[0078] In one embodiment, a radar-like detection system may be used in order to maintain the distance between the vehicle in front of the driver's truck or other vehicle. This would allow the driver to maintain a safe distance between his vehicle and the one in front of him. In another embodiment, a light source of a specific frequency might be used to

reflect off the vehicle in front, the time being gauged very accurately so as to determine the distance between the two vehicles. Other means may also be used. Generally, one second of time should exist between the vehicles for each ten (10) miles-per-hour of speed.

[0079] With the development of wireless applications, information regarding the vehicle may be transmitted to a satellite uplink and then distributed to a central or Internet-based information distribution system. Devices such as those known as the Palm Pilot (marketed by 3Com) may be used to access the data and monitor the travel of the vehicle across the U.S. or otherwise. A panic button or the like may also be included in such wireless applications, immediately notifying authorities in case an event of highway piracy or vehicle breakdown should occur.

[0080] GPS applications may also be used, such that the satellite uplink information includes information derived from the Global Positioning System (GPS). Geographical information in the form of longitude and latitude are then delivered with the satellite uplink information. Additionally, information regarding the status of the vehicle according to its disposition and its lane of travel can also be uploaded, as well as a history of any alerts that may have occurred. With respect to the latter, the association of the turn signal with the black box becomes a significant feature as such alerts would be generated without the coupling of the turn signal to the black box.

[0081] Additionally, automatic log book applications could be coordinated with the black box of the present invention in order to provide automatic logging of the travel, expenses, and other relevant data with respect to the operation, maintenance, and mileage of the vehicle.

[0082] As forecasted by some, JavaScript applications or the like can be used with respect to all mechanical items on the vehicle. For example, when the oil reaches the end of its useful life, a signal can be given that the oil should be changed. Additionally, headlights that are about to go out or that have been used passed 90% of their useful life can also give signals that they are ready to be replaced, and the same can then be transmitted automatically for the next scheduled maintenance stop for the vehicle.

[0083] By providing a travel-detection and maintenance system along the lines described above, greater safety is provided for both the driver and those travelling along the same roads as the vehicle. This may allow for greater cargo capacities to be allowed on the highways, as wireless and other monitoring of the vehicle provide a greater margin of safety, possibly far exceeding that necessary for safe operation.

[0084] While the present invention has been described with regards to particular embodiments, it is recognized that

additional variations of the present invention may be devised without departing from the inventive concept.

1-38. (canceled)

39. A method for testing potential driver ability, the steps comprising:

- providing a circle;
- tracing said circle, said circle traced by a driver; and
- detecting departure from said circle by said tracing; whereby manual dexterity and/or eye/hand coordination is indicated by said detection of departure of said tracing from said circle.

40. A method for testing potential driver ability, the steps comprising:

- providing a moving target;
- tracking said moving target, said tracking performed by a driver; and
- detecting accuracy and speed of said tracking of said moving target; whereby speed and accuracy of said tracking are determined by said detecting.

41-47. (canceled)

48. A method for testing a driver's performance comprising:

- providing a random sound command, image projection, or a combination of both;
- responding to said image, said responding performed by the driver; and
- determining the speed and accuracy of said responding.

49. The method of claim 48 wherein said sound command and image projection are provided while the driver is driving, said image projection being projected on the windshield of the vehicle wherein

alertness of the driver is determined by the speed and accuracy of said responding.

50. A method of monitoring a driver comprising:

- recording the driver's brain wave patterns;
- determining the character of said patterns when the driver is drowsy or falling asleep;
- monitoring the driver's brain waves while driving;
- comparing said patterns when the driver is drowsy or falling asleep to the brain waves while driving; and
- determining when the driver is drowsy or falling asleep based on said comparing.

* * * * *