

(19) **DANMARK**

(10) **DK/EP 3077773 T3**



(12) **Oversættelse af
europæisk patentskrift**

Patent- og
Varemærkestyrelsen

-
- (51) Int.Cl.: **G 01 F 1/66 (2006.01)** **G 01 D 4/00 (2006.01)** **G 01 F 15/06 (2006.01)**
H 01 Q 7/00 (2006.01) **H 05 K 1/14 (2006.01)**
- (45) Oversættelsen bekendtgjort den: **2020-06-15**
- (80) Dato for Den Europæiske Patentmyndigheds bekendtgørelse om meddelelse af patentet: **2020-03-18**
- (86) Europæisk ansøgning nr.: **13802870.9**
- (86) Europæisk indleveringsdag: **2013-12-03**
- (87) Den europæiske ansøgnings publiceringsdag: **2016-10-12**
- (86) International ansøgning nr.: **DK2013050408**
- (87) Internationalt publikationsnr.: **WO2015081958**
- (84) Designerede stater: **AL AT BE BG CH CY CZ DE DK EE ES FI FR GB GR HR HU IE IS IT LI LT LU LV MC MK MT NL NO PL PT RO RS SE SI SK SM TR**
- (73) Patenthaver: **APATOR MIITORS ApS, Bautavej 1 A, Hasle, 8210 Århus V, Danmark**
- (72) Opfinder: **DRACHMANN, Jens, Rosendalvej 42, 8260 Viby J, Danmark**
- (74) Fuldmægtig i Danmark: **Patentgruppen A/S, Arosgården, Åboulevarden 31, 8000 Århus C, Danmark**
- (54) Benævnelse: **FORBRUGSMÅLER OMFATTENDE EN SAMMENFOLDELIG PRINTKORTENHED**
- (56) Fremdragne publikationer:
EP-A1- 2 336 732
EP-A2- 1 983 311
US-B1- 6 304 231
US-B2- 8 033 183

DESCRIPTION

[0001] The present invention relates to a consumption meter, such as an ultrasonic flow meter, comprising a printed circuit board assembly, which can be folded to form a compact assembly extending in three geometric planes.

Background of the invention

[0002] A well-known physical limitation, which can be hindering the efforts of reducing the physical size of wireless consumption meters, is the fact that the radio frequency (RF) antenna used for communication with a distant central control unit requires certain dimensions in order to obtain the appropriate resonance frequency of the antenna. Although it is possible to make RF antennas with smaller physical dimensions than normal for a given resonance frequency, it is a well-known problem that the efficiency of such small antennas is not very high.

[0003] EP 1 983 311 A2 discloses a consumption meter with three connected PCBs arranged in a U-shape enclosing the flow channel. The three PCBs include a side PCB with the antenna and a side PCB with the battery arranged in parallel planes with the flow channel between them, and a top PCB with electronics and display.

Brief description of the invention

[0004] It is an object of the invention to provide a solution, which overcomes or at least reduces the above-mentioned problem.

[0005] The present invention is defined by the independent claims 1 and 11. The specific embodiments of the present invention are defined by the dependent claims 2-10 and 12-15.

[0006] The present invention relates to a consumption meter comprising a foldable printed circuit board assembly, which foldable printed circuit board assembly comprises a printed circuit board substrate having at least a first and a second rigid part, wherein electronic components and a battery are mounted on the first rigid part, which also comprises an electrical ground plane, and a radio frequency (RF) antenna extends mainly on the second rigid part, a first flexible part of the printed circuit board substrate being arranged to allow the printed circuit board assembly to be folded so that the first and second rigid parts extend in two different but substantially parallel geometric planes.

[0007] In an embodiment of the invention, the first flexible part connects the second rigid part to a third rigid part of the printed circuit board substrate onto which a part of the RF antenna extends, the third rigid part being configured to extend in a geometric plane substantially

perpendicular to the geometric planes in which the first and the second part extend when the printed circuit board assembly is folded.

[0008] The use of a folded printed circuit board assembly means that a more compact and less space-consuming printed circuit board assembly and consumption meter construction can be obtained. This is especially important for flow meters, in which the electronics must be protected from moisture and water, typically by embedding or enclosing the electronics in a watertight enclosure. In this relation, smaller volumes means less production costs.

[0009] Folding the printed circuit board as described means that a box-shaped folded assembly with the electronic components placed inside the "box", i.e. between the two rigid parts extending in parallel planes, can be obtained. Such a shape of the assembly means that it is well-suited for being installed in many different places, such as consumption meter housings, which are often box-shaped.

[0010] Furthermore, the arrangement of the electrical ground plane and the RF antenna on two rigid parts of the printed circuit board substrate, respectively, which extend in two different but substantially parallel geometric planes means that, if the printed circuit board assembly is appropriately oriented within the consumption meter, the ground plane on the first rigid part can be placed between the RF antenna and the flow channel. Thus, the ground plane works as a stable electrical counterweight for the RF antenna and the same type and size of RF antenna can be used for different sizes of consumption meters. In other consumption meters known from the art, this electrical counterweight is formed by the ground plane on a printed circuit board itself and/or a flow channel through which a fluid to be metered flows. In that case, the RF antenna must be dimensioned depending on the size of the consumption meter in order to match the actual electrical counterweight. Furthermore, an electrical counterweight involving a non-conductive flow channel, for instance made of a plastic material, is less stable due to the fact that the performance will depend on whether a conductive fluid, such as water, is actually present within the flow channel or not.

[0011] Another advantage obtained by orienting the printed circuit board assembly as described is that the RF antenna gets the maximum possible free space in relation to the conductive parts in the consumption meter including the electronic components on the first rigid part of the printed circuit board substrate resulting in optimal radiation characteristics of the RF antenna.

[0012] Letting the RF antenna extend in two different geometric planes of the folded printed circuit board assembly has surprisingly shown to result in the effect that an RF antenna with a given resonance frequency can be made shorter than otherwise expected, meaning that a more compact printed circuit board assembly, which takes up less space, for instance in an installation box in which the assembly is installed, can be obtained.

[0013] In an embodiment of the invention, a second flexible part is arranged to connect the first rigid part and the third rigid part to each other.

[0014] Using such configuration, the complete printed circuit board substrate can be produced in one piece, which reduces the production costs.

[0015] In an embodiment of the invention, an electrical connector is inserted between the first and the third rigid part of the printed circuit board substrate and arranged to releasably connect the first and the third rigid parts to each other.

[0016] The releasable connection between the first and the third rigid part of the printed circuit board substrate to each other means that a given first rigid part of the printed circuit board substrate being equipped with a standard set of electronic components can be combined with different sets of second and third rigid parts comprising RF antennas of different lengths and, thereby, different frequency bands, respectively. Thus, the flexibility of the system is increased.

[0017] In an embodiment of the invention, the third rigid part comprises an electrical ground plane.

[0018] Letting the electrical ground plane extend onto the third rigid part further increases the counterweight properties of the ground plane and further reduces the influence of the size of the flow channel.

[0019] In an embodiment of the invention, the RF antenna extends on the inner side of the folded circuit board assembly, i.e. on the side of the second rigid part of the printed circuit board substrate facing the first rigid part and, where applicable, on the side of the third rigid part of the printed circuit board substrate facing the first and the second rigid parts.

[0020] Letting the RF antenna extend on the inner side of the folded circuit board assembly, i.e. on the same side as the electronic components, means that the RF antenna can be connected directly to the relevant electronic components without having the antenna signal passing through the printed circuit board substrate from one side thereof to the other. This is advantageous because the so-called vias used for making electric connections through a printed circuit substrate can be detrimental for high frequency signals due to the fact that the physical structure of the vias causes them to represent uncontrollable inductances.

[0021] In an embodiment of the invention, the foldable printed circuit board assembly further comprises a Near Field Communication (NFC) antenna extending mainly on the second rigid part of the printed circuit board substrate.

[0022] The inclusion of an NFC antenna enables for simple and easy communication with other electronic devices, for instance for receiving simple commands and the like from external devices. For the NFC antenna, it is even more important than for the RF antenna that the radiation characteristics are optimized as described above.

[0023] In an embodiment of the invention, a cutout is made in the second rigid part of the

printed circuit board substrate so that a display, which is mounted with the other electronic components on the first rigid part thereof, is clearly visible through the cutout in the second rigid part, when the printed circuit board assembly is folded.

[0024] Such a configuration allows the second rigid part carrying the main part of the RF antenna and, where relevant, also the NFC antenna, to be placed on top of the folded printed circuit board assembly without blocking the sight to the display mounted on the first rigid part arranged there below.

[0025] In an embodiment of the invention, the electronic components constitute the necessary electronics to drive and control a consumption meter, such as an ultrasonic flow meter.

[0026] In an embodiment of the invention, the consumption meter is an ultrasonic flow meter, such as a water consumption meter, a gas consumption meter or a heat consumption meter.

Figures

[0027] In the following, an exemplary embodiment of the invention is described in more detail with reference to the figures, of which

Figs. 1a-1c

are a top view, a bottom view and a side view, respectively, of a foldable printed circuit board assembly according to an embodiment of the invention,

Fig. 2

is a perspective view of the same foldable printed circuit board assembly as shown in Figs. 1a-1c,

Figs. 3a and 3b

are side views of a foldable printed circuit board assembly according to another embodiment of the invention in an unassembled and unfolded configuration and in an assembled and folded configuration, respectively,

Fig. 4

is a perspective view of the printed circuit board assembly shown in the previous figures when folded into three geometric planes to form a very compact assembly,

Fig. 5

is a perspective view of an ultrasonic flow meter according to an embodiment of the invention, and

Fig. 6

is an exploded view of the same ultrasonic flow meter as shown in Fig. 5.

Detailed description of the invention

[0028] Figs. 1a-1c are a top view, a bottom view and a side view, respectively, of a foldable printed circuit board assembly 1 according to an embodiment of the invention. Fig. 2 is a perspective view of the same foldable printed circuit board assembly 1.

[0029] In the illustrated embodiment, a number of electronic components 8, a battery (not specifically indicated in the figures), an NFC antenna 9 and an RF antenna 10 are mounted on a printed circuit board substrate consisting of five different parts 2-6. Three rigid parts 2-4 are separated from each other by two flexible parts 5, 6. The electronic components 8 are mounted on the first rigid part 2 of the printed circuit board substrate, and the two antennas 9, 10 extend mainly on the second rigid part 3 but also partly on the third rigid part 4 of the printed circuit board substrate.

[0030] The second rigid part 3 of the printed circuit board substrate comprises a throughgoing cutout 11 to make a display (not shown in any of Figs. 1a-3b) visible through this second rigid part 3, as can be seen in Fig. 4. The first rigid part 2 of the printed circuit board substrate comprises two lines of mounting holes 12 for the mounting and electric contact of this display to the printed circuit board substrate.

[0031] The fact that the flexible parts 5, 6 of the printed circuit board substrate are bendable means that the printed circuit board assembly 1 can be folded to form a very compact box-shaped assembly as illustrated in Fig. 4.

[0032] Figs. 3a and 3b show a slightly different embodiment of the printed circuit board assembly in that the second flexible part 6 from the previous figures has been replaced by a connector 7 mounted on the first rigid part 2 of the printed circuit board substrate, into which connector 7 the third rigid part 4 can be fitted to form a physical and electrical connection between these two rigid parts 2, 4. In other embodiments, the connection between the first 2 and third 4 rigid parts may further comprise one or more cables or another flexible part (not shown) along with the connector 7 so that the connection is bendable like the first flexible part 5 rather than fixed in a 90° position as illustrated in Fig. 3b, or the connector 7 may consist of two parts mounted on the two rigid parts 2, 4 of the printed circuit board substrate, respectively.

[0033] Fig. 4 is a perspective view of the printed circuit board assembly 1 shown in Figs. 1a-1c and Fig. 2 when folded into three geometric planes to form such a compact box-shaped assembly with the electronic parts 8 extending into the "box" from the bottom thereof, which is formed by the first rigid part 2 of the printed circuit board substrate. The two antennas 9, 10 extend mainly along the top of the "box" formed by the second rigid part 3 of the printed circuit board substrate but also partly on the flexible part 5 and, preferably, on side of the "box", which is formed by the third rigid part 4 of the printed circuit board substrate.

[0034] Fig. 4 further illustrates how a display 13 is mounted in the mounting holes 12 of the first rigid part 2 of the printed circuit board substrate, which are illustrated in Figs. 1a and 1b. In

the illustrated embodiment, the display 13 is mounted by means of a number of mounting and connection pins 14 so that it forms a "bridge" over at least some of the electronic components 8 and faces upwards against the second rigid part 3 of the printed circuit board assembly. This is why the cutout 11 in the second rigid part 3 is necessary in order to make the display 13 visible from outside the folded printed circuit board assembly 1.

[0035] Figs. 5 and 6 are a perspective view and an exploded view, respectively, of an ultrasonic flow meter 15 according to an embodiment of the invention, which comprises a printed circuit board assembly 1 as described above.

[0036] As illustrated in Fig. 5, the ultrasonic flow meter 15 basically consists of a housing 16, which is mounted to a flow channel 17 through which the medium to be metered, such as for instance water, flows. The housing 16, which is hermetically sealed by means of a lid 26 and a sealing 27, is mounted to the flow channel 17 by means of a mechanical locking mechanism 18 mounted on the flow channel 17 and a couple of locking pins 19 to be inserted after placing the housing 16 on the locking mechanism 18.

[0037] As can be seen from Fig. 6, the housing 16 comprises two ultrasonic transducers 22 and a folded printed circuit board assembly 1 as described above with the necessary electronics and a battery for driving and controlling the function of the flow meter 15 as well as NFC and RF antennas for wireless communication to and from the flow meter 15. A connection arrangement comprising two insulating parts 23, 25 and an electrically conducting part 24 ensures that the ultrasonic transducers 22 are held physically in place and that there is a good electrical contact between the transducers 22 and the electronics in the printed circuit board assembly 1.

[0038] Fig. 6 further shows how a flow channel insert 20 with a number of ultrasound reflectors 21 are placed inside the flow channel 17 to ensure a well-defined and controlled path of the ultrasound from one ultrasonic transducer 22 to the other through the medium to be metered.

[0039] The illustrated embodiment of an ultrasonic flow meter 15 is just to be seen as one example of consumption meters or other electronic devices in which a folded printed board assembly 1 as described above can be used.

List of reference numbers

[0040]

1. 1. Foldable printed circuit board assembly
2. 2. First rigid part of printed circuit board substrate
3. 3. Second rigid part of printed circuit board substrate
4. 4. Third rigid part of printed circuit board substrate
5. 5. First flexible part of printed circuit board substrate

6. 6. Second flexible part of printed circuit board substrate
7. 7. Connector for connecting rigid parts of printed circuit board substrate
8. 8. Electronic components of printed circuit board assembly
9. 9. NFC antenna
10. 10. RF antenna
11. 11. Cutout for display
12. 12. Mounting holes for display pins
13. 13. Display
14. 14. Mounting and connection pins for display
15. 15. Ultrasonic flow meter
16. 16. Housing
17. 17. Flow channel
18. 18. Locking mechanism for housing
19. 19. Locking pin for housing
20. 20. Flow channel insert
21. 21. Ultrasound reflector
22. 22. Ultrasound transducer
23. 23. First insulating part of connection arrangement
24. 24. Conducting part of connection arrangement
25. 25. Second insulating part of connection arrangement
26. 26. Lid for housing
27. 27. Hermetical sealing for housing

REFERENCES CITED IN THE DESCRIPTION

This list of references cited by the applicant is for the reader's convenience only. It does not form part of the European patent document. Even though great care has been taken in compiling the references, errors or omissions cannot be excluded and the EPO disclaims all liability in this regard.

Patent documents cited in the description

- [EP1983311A2 \[0003\]](#)

Patentkrav

1. Forbrugsmåler, der omfatter en sammenfoldelig printkortenhed (1), hvilken sammenfoldelig printkortenhed omfatter et printkortunderlag, der har i det mindste en første (2) og en anden (3) stiv del, og en radiofrekvensantenne (10) (RF-antenne)
5 strækker sig hovedsagelig på den anden stive del (3),

kendetegnet ved, at

elektroniske komponenter (8) og et batteri er monteret på den første stive del, som også omfatter et elektrisk stelplan, og
idet en første fleksibel del (5) af printkortunderlaget er anbragt med henblik på at
10 tillade, at printkortenheden kan foldes, således at den første og den anden stive del strækker sig i to forskellige, men i det væsentlige parallelle geometriske planer, idet nævnte elektriske stelplan på den første stive del (2) er placeret mellem nævnte anden stive dels (3) nævnte radiofrekvensantenne (10) og en strømningskanal (17), hvorigennem et fluid, der skal måles af nævnte forbrugsmåler, strømmer.

15

2. Forbrugsmåler ifølge krav 1, hvor den første fleksible del forbinder den anden stive del med en tredje stiv del (4) af printkortunderlaget, over på hvilken en del af RF-antennen strækker sig, idet den tredje stive del er konfigureret til at strække sig i et geometrisk plan, der er i det væsentlige vinkelret på de geometriske planer, i
20 hvilke den første og den anden del strækker sig, når printkortenheden er foldet.

3. Forbrugsmåler ifølge krav 2, hvor en anden fleksibel del (6) er anbragt med henblik på at forbinde den første stive del og den tredje stive del med hinanden.

25 4. Forbrugsmåler ifølge krav 2 eller 3, hvor en elektrisk konektor (7) er indført mellem den første og den tredje stive del af printkortunderlaget og anbragt med henblik på frigøreligt at forbinde den første og den tredje stive del med hinanden.

- 5 **5.** Forbrugsmåler ifølge et hvilket som helst af kravene 2-4, hvor den tredje stive del omfatter et elektrisk stelplan.
- 5 **6.** Forbrugsmåler ifølge et hvilket som helst af de foregående krav, hvor RF-antennen strækker sig på indersiden af den foldede printkortenhed, dvs. på den side af printkortunderlagets anden stive del, der vender mod den første stive del, og, hvor det er relevant, på den side af den tredje stive del af printkortunderlaget, der vender mod den første og den anden stive del.
- 10 **7.** Forbrugsmåler ifølge et hvilket som helst af de foregående krav, som endvidere omfatter en NFCantenne (9) (Near Field Communication), der hovedsagelig strækker sig på printkortunderlagets anden stive del.
- 15 **8.** Forbrugsmåler ifølge et hvilket som helst af de foregående krav, hvor der er foretaget en udskæring (11) i den anden stive del af printkortunderlaget, således at et display (13), der er monteret sammen med de øvrige elektroniske komponenter på den første stive del deraf, er tydeligt synligt gennem udskæringen i den anden stive del, når printkortenheden er foldet.
- 20 **9.** Forbrugsmåler ifølge et hvilket som helst af de foregående krav, hvor de elektroniske komponenter udgør den nødvendige elektronik til at drive og styre en forbrugsmåler, såsom en ultralydsflowmåler (15).
- 25 **10.** Forbrugsmåler ifølge et hvilket som helst af de foregående krav, hvor forbrugsmåleren er en ultralydsflowmåler, såsom en vandforbrugsmåler, en gasforbrugsmåler eller en varmekonsummåler.
- 30 **11.** Fremgangsmåde til fremstilling af en forbrugsmåler, hvilken fremgangsmåde omfatter trinnene til tilvejebringelse af en sammenfoldelig printkortenhed (1), og foldning af den sammenfoldelige printkortenhed (1), således at en første (2) og en

anden (3) stiv del strækker sig i to forskellige, men i det væsentlige parallelle geometriske planer, og

den sammenfoldelige printkortenhed omfatter en radiofrekvensantenne (10) (RF-antenne), der hovedsagelig strækker sig på den anden del (3),

5 kendetegnet ved, at

den sammenfoldelige printkortenhed endvidere omfatter

et printkortunderlag, der har i det mindste den første (2) og den anden (3) stive del, hvor elektroniske komponenter (8) og et batteri er monteret på den første stive del (2), der også omfatter et elektrisk stelplan, og

10 en første fleksibel del (5), der er anbragt mellem nævnte første (2) og anden (3) stive del med henblik på at tillade, at printkortenheden (1) kan foldes, og

fremgangsmåden endvidere omfatter trinnet til montering af den sammenfoldelige printkortenhed (1) inde i et hus (16) af nævnte forbrugsmåler, således at nævnte elektriske stelplan på den første stive del (2) er placeret mellem nævnte anden stive

15 dels (3) nævnte radiofrekvensantenne (10) og en strømningskanal (17), hvorigennem et fluid, der skal måles af nævnte forbrugsmåler, strømmer.

12. Fremgangsmåde til fremstilling ifølge krav 11, hvor den første fleksible del (5) forbinder den anden stive del (3) med en tredje stiv del (4) af printkortunderlaget,

20 over på hvilket en del af RF-antennen (10) strækker sig, idet den tredje stive del (4) er konfigureret til at strække sig i et geometrisk plan, der er i det væsentlige vinkelret på de geometriske planer, i hvilke den første (2) og den anden (3) del strækker sig, når printkortenheden er foldet.

25 **13.** Fremgangsmåde til fremstilling ifølge krav 12, hvor en elektrisk konektor (7) indføres mellem printkortunderlagets første (2) og tredje (4) stive del og anbringes med henblik på frigøreligt at forbinde den første (2) og den tredje (4) stive del med hinanden.

30 **14.** Fremgangsmåde til fremstilling ifølge et hvilket som helst af kravene 11 til 13, hvor den sammenfoldelige printkortenhed (1) endvidere omfatter en NFC-

antenne (9) (Near Field Communication), der hovedsagelig strækker sig på printkortunderlagets anden stive del (3).

15. Fremgangsmåde til fremstilling ifølge et hvilket som helst af kravene 11 til 14,

5 hvilken fremgangsmåde omfatter følgende trin:

montering af et display (13) sammen med de øvrige elektroniske

komponenter (8) på den første stive del (2), og

foretagelse af en udskæring (11) i printkortunderlagets anden stive del (3),

således at displayet (13) er tydeligt synligt gennem udskæringen (11) i den

10 anden stive del (3), når printkortenheden (1) er foldet.

DRAWINGS

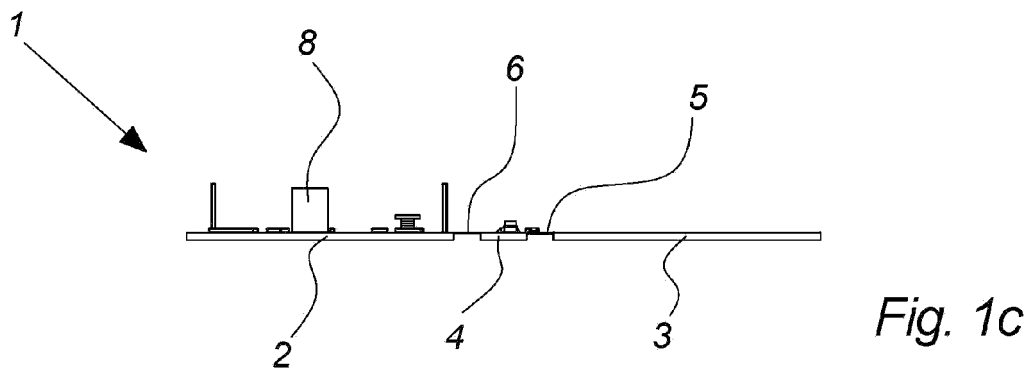
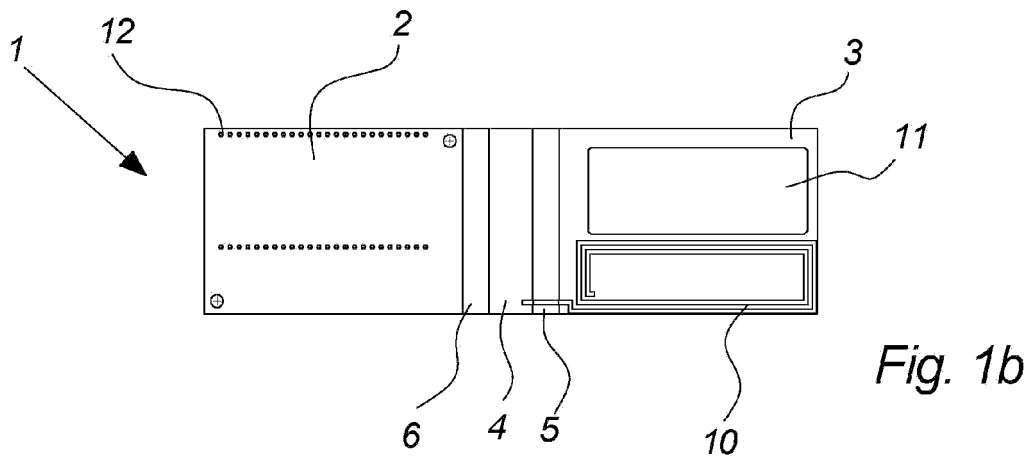
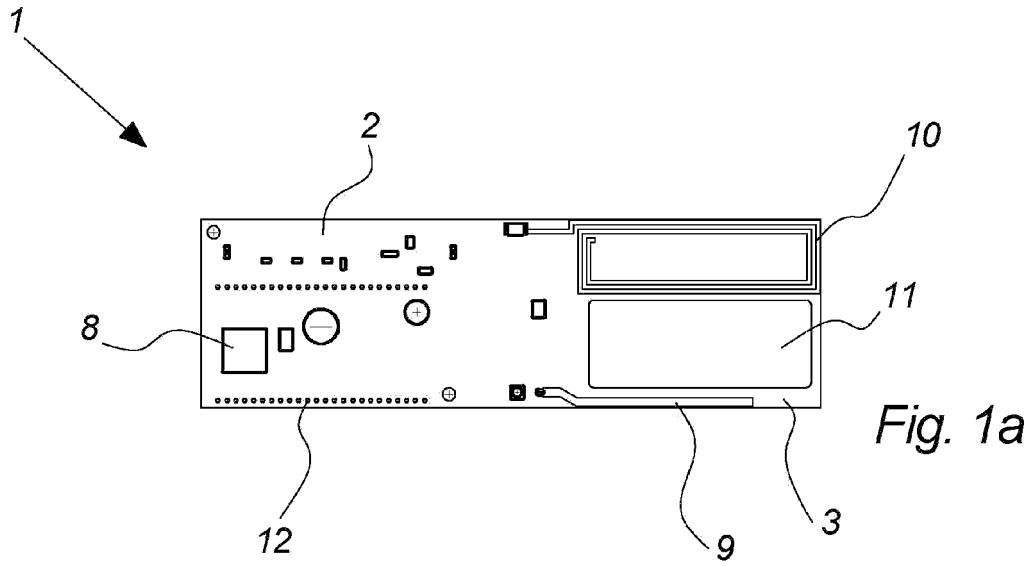

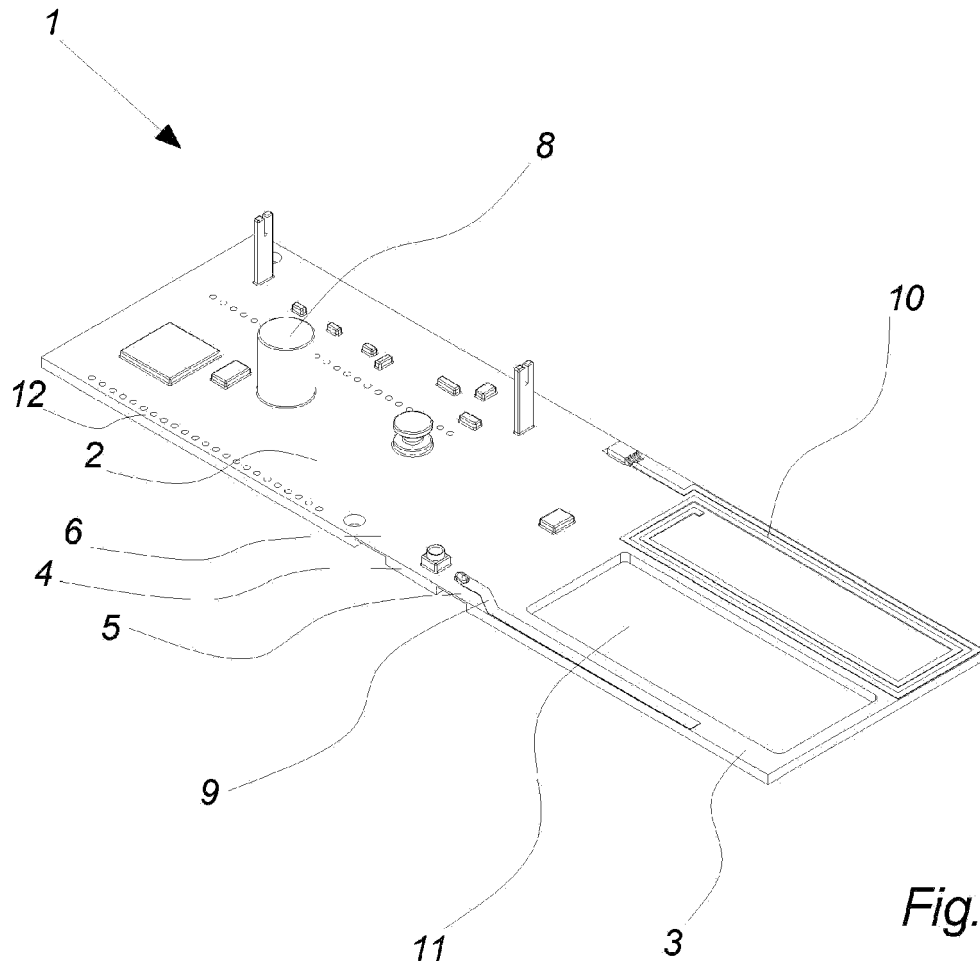

Fig. 2

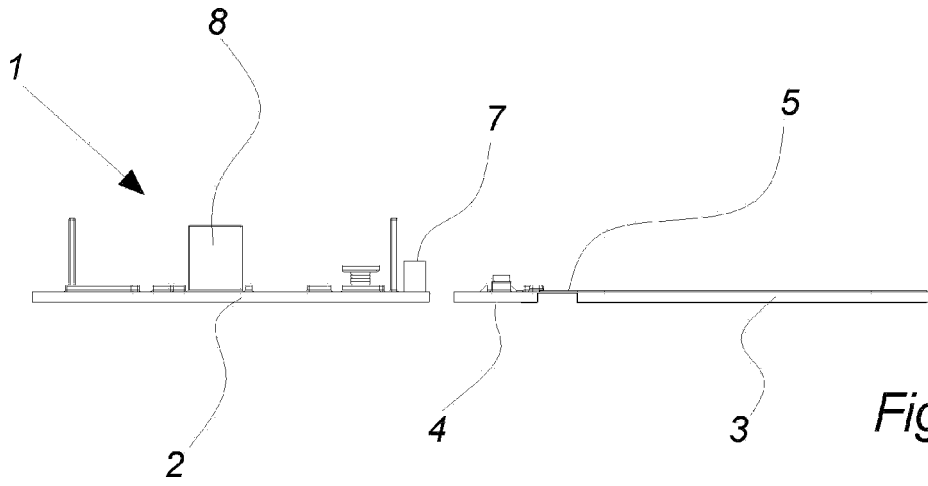

Fig. 3a

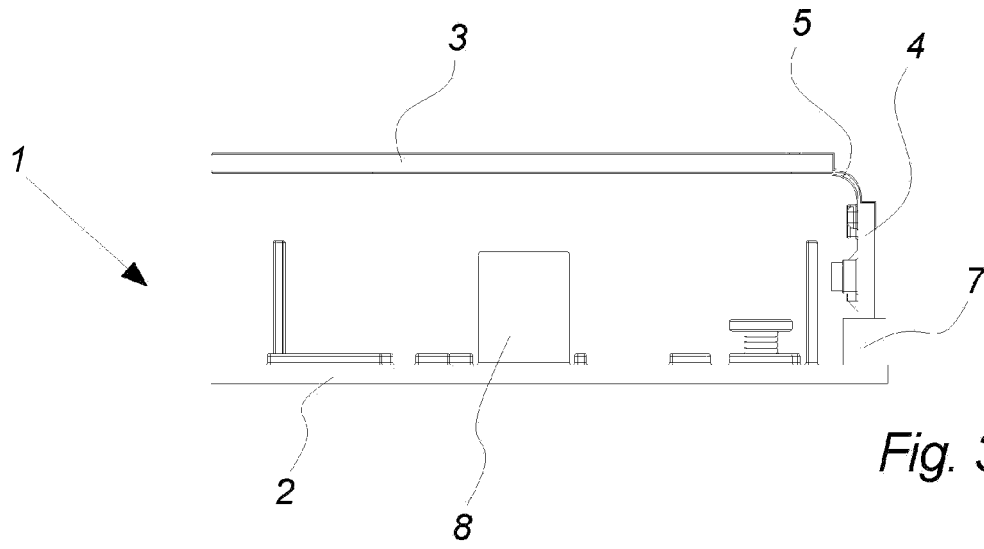

Fig. 3b

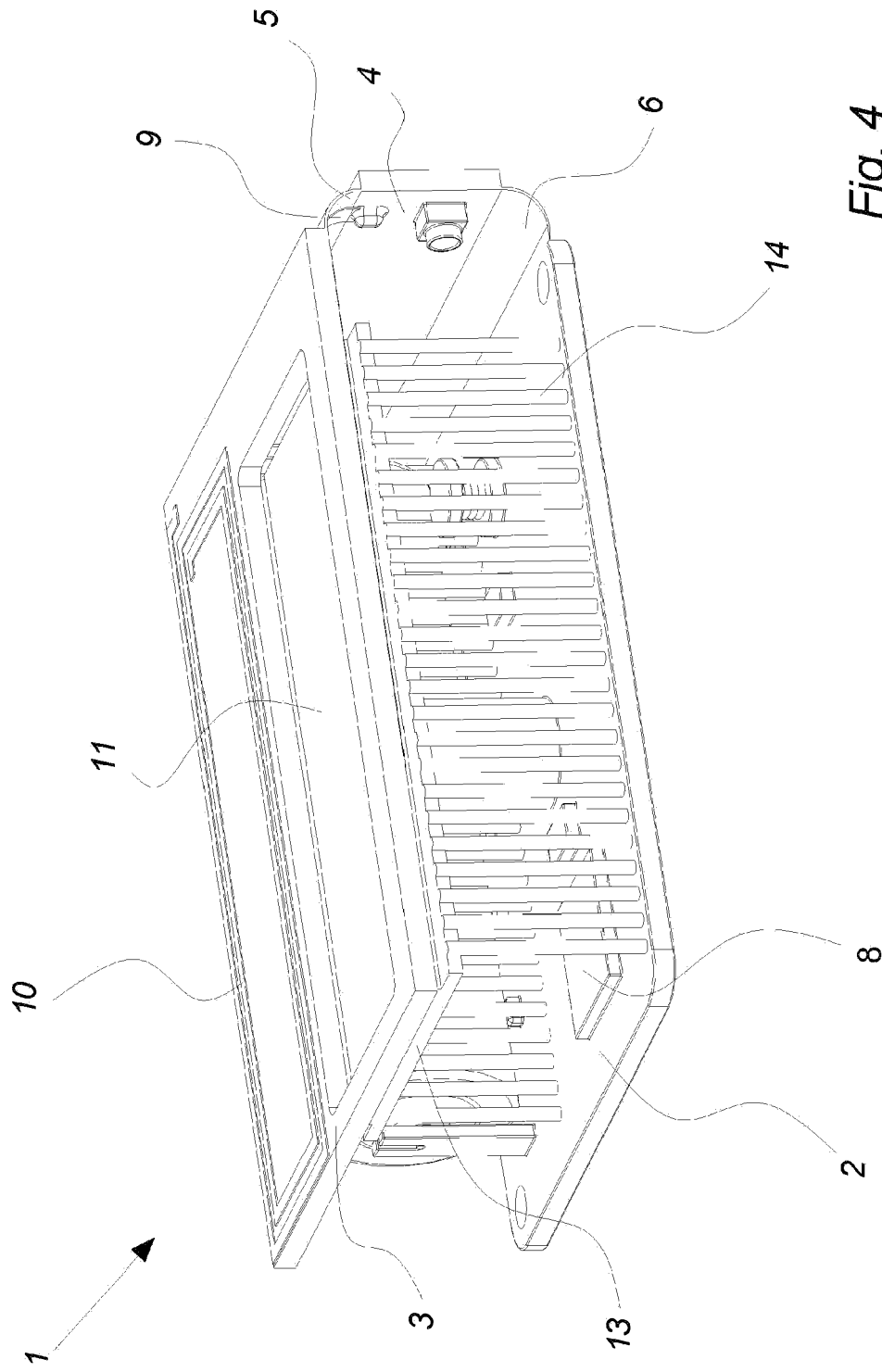

Fig. 4

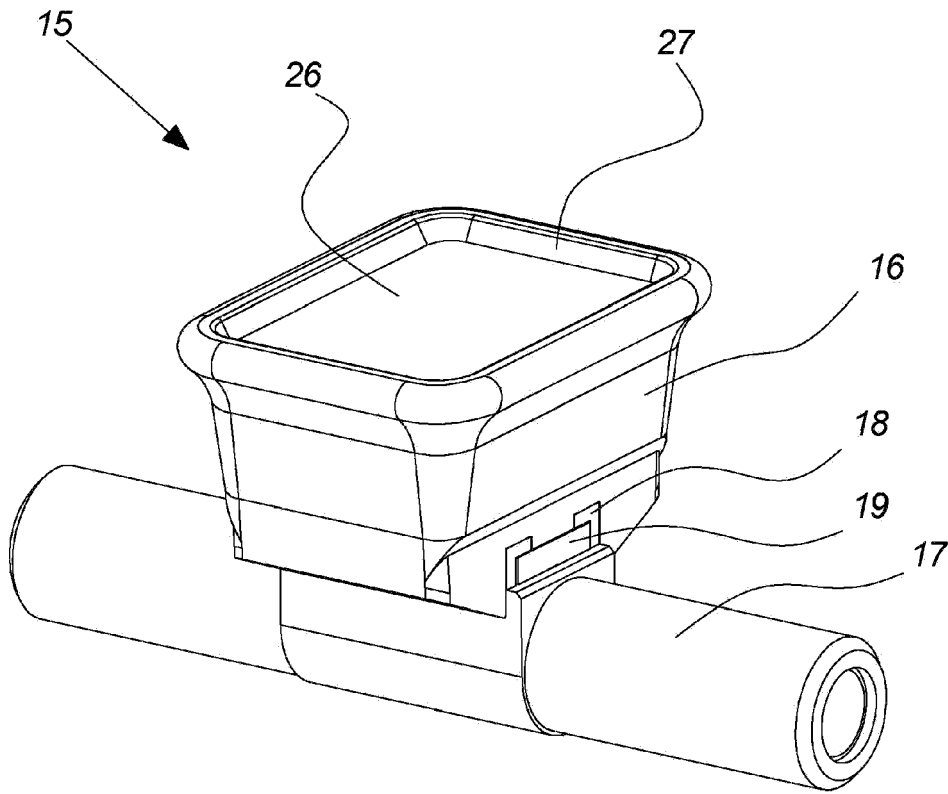

Fig. 5

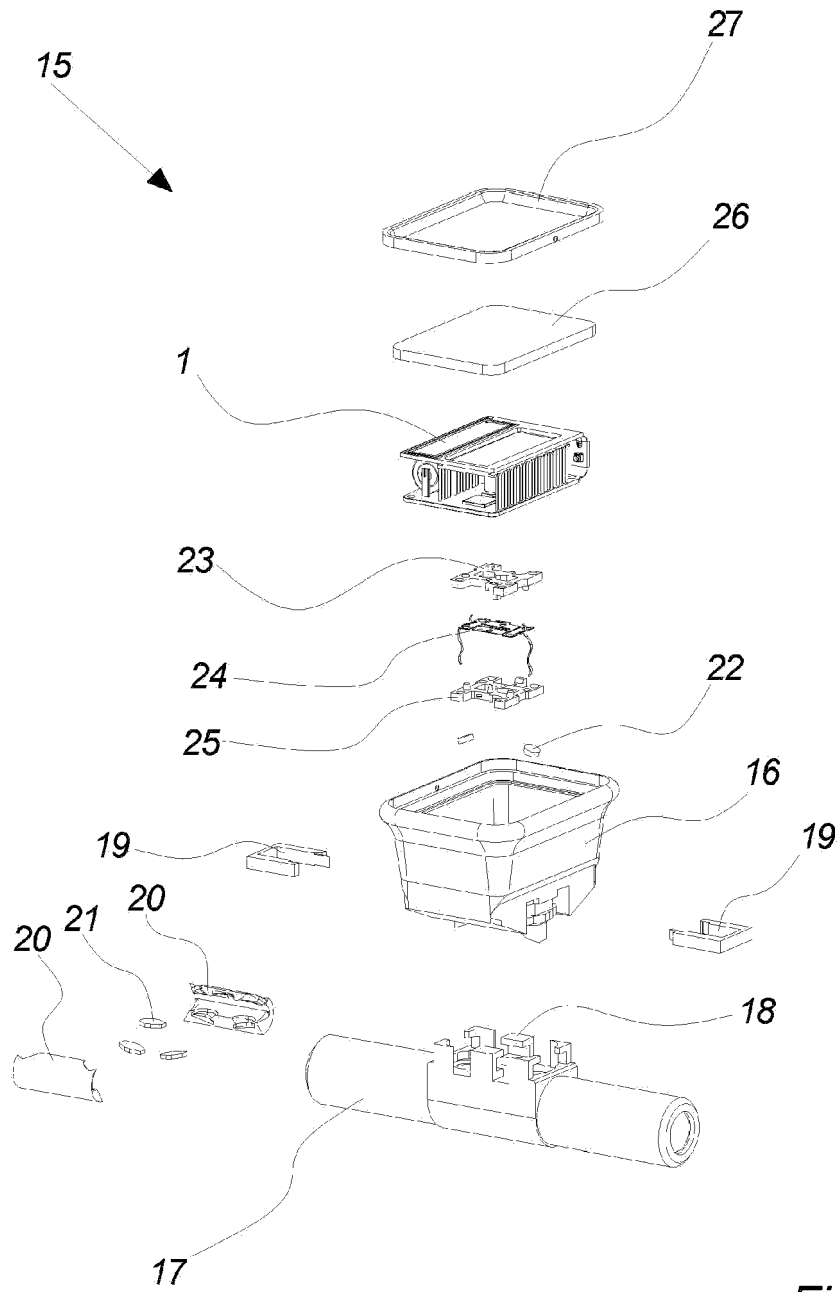

Fig. 6