



Europäisches Patentamt
European Patent Office
Office européen des brevets



(11) **EP 1 603 809 B1**

(12) **EUROPEAN PATENT SPECIFICATION**

(45) Date of publication and mention
of the grant of the patent:
20.09.2006 Bulletin 2006/38

(51) Int Cl.:
B65D 49/04^(2006.01) B65D 55/08^(2006.01)

(21) Application number: **03712661.2**

(86) International application number:
PCT/IT2003/000141

(22) Date of filing: **07.03.2003**

(87) International publication number:
WO 2004/078612 (16.09.2004 Gazette 2004/38)

(54) **TAMPER EVIDENT CLOSURE FOR BOTTLES, PARTICULARLY FOR BOTTLES CONTAINING VALUABLE DRINKS**

ORIGINALITÄTSVERSCHLUSS FÜR FLASCHEN, INSBESONDERE ENTHALTEND WERTVOLLE GETRÄNKE

DISPOSITIF DE FERMETURE INVOLABLE POUR BOUTEILLES, EN PARTICULIER POUR DES BOUTEILLES CONTENANT DES BOISSONS DE VALEUR

(84) Designated Contracting States:
**AT BE BG CH CY CZ DE DK EE ES FI FR GB GR
HU IE IT LI LU MC NL PT RO SE SI SK TR**

(72) Inventor: **BATTEGAZZORE, Piero
I-15100 Alessandria (IT)**

(43) Date of publication of application:
14.12.2005 Bulletin 2005/50

(74) Representative: **Perani, Aurelio et al
Perani Mezzanotte & Partners
Piazza San Babila 5
20122 Milano (IT)**

(73) Proprietor: **GUALA CLOSURES S.P.A.
15100 Alessandria AL (IT)**

(56) References cited:
**EP-A- 1 238 919 FR-A- 2 179 622
GB-A- 2 302 867 US-A- 2 723 773**

EP 1 603 809 B1

Note: Within nine months from the publication of the mention of the grant of the European patent, any person may give notice to the European Patent Office of opposition to the European patent granted. Notice of opposition shall be filed in a written reasoned statement. It shall not be deemed to have been filed until the opposition fee has been paid. (Art. 99(1) European Patent Convention).

Description

[0001] The invention relates to a tamper evident closure for a bottle suitable for containing valuable drinks in accordance with the preamble to claim 1. One such closure is disclosed, for example, by US 2,723,773.

[0002] There are known closures for bottles which give a visible indication of attempts to remove them forcibly for fraudulent reasons.

[0003] These closure devices are designed to prevent the original drink contained in the bottle from being replaced with another counterfeit drink.

[0004] To commit the fraud, the operations carried out by the counterfeiters consist, for example, in recovering an empty bottle already used, fitted with the relevant closure with the seal broken, but with the internal valve components intact, refilling it with an equivalent but low-value drink and re-closing the bottle by reconstructing the seal.

[0005] In other cases, it has been found that to defraud the customer, attempts are sometimes made to remove the closure from the bottle without opening the closure itself so that the valuable product contained in the bottle can be replaced with another product of lesser value.

[0006] The closure disclosed in US 2,723,773, however, requires bottles having a slanted surface on their neck in order to provide the visible indication that the closure has been tampered with.

[0007] In consideration of the points mentioned above, the purpose of the invention is to propose a closure for bottles which has still more effective tamper evident means compared with those offered by known closures and which make the action of tampering as evident as possible and in an irreversible manner.

[0008] The purpose of the invention is therefore to provide a closure which can be used also onto bottles without a ridge.

[0009] According to the invention, this purpose is achieved by means of a tamper evident closure for bottles, particularly for bottles containing valuable drinks according to the characterizing part of claim 1.

[0010] By means of the invention it is possible to produce a closure capable of giving an immediately visible indication of any attempt to break into the bottle where an attempt is made to remove or prize off the closure device.

[0011] The characteristics and advantages of the invention will become clear from the following detailed description of several forms of practical embodiment, illustrated purely by way of non-limiting example in the appended drawings, in which:

figure 1A shows a front view of a first form of embodiment, partly in section, of a closure for bottles according to the invention;

figure 1B shows a view at an enlarged scale of a first portion of the closure in figure 1A;

figure 1C shows a view at an enlarged scale of another portion of the closure in figure 1A;

figure 1D shows a perspective view of a component of the closure in figure 1A;

figure 2A shows a front view, partly in section, of a closure for bottles not according to the invention;

figure 2B shows a view at an enlarged scale of a portion of the closure in figure 2A;

figure 3A shows a front view of a third form of embodiment, partly in section, of a closure for bottles according to the invention;

figure 3B shows a view at an enlarged scale of a portion of the closure in figure 3A;

figure 4A shows a front view of a fourth form of embodiment, partly in section, of a closure for bottles according to the invention;

figure 4B shows a view at an enlarged scale of a portion of the closure in figure 4A.

[0012] With reference to figures 1A-1D, the closure according to the invention is indicated by the number 1, while the bottle, the upper part only of which is shown, is indicated by the number 2.

[0013] The bottle 2, conventional in itself, comprises a neck 3, of substantially cylindrical shape and having a mouth 4 and a body 5 connected externally to the neck 3.

[0014] The closure 1 comprises a pouring unit 6 of known type and which will therefore not be described below in detail, but only in its basic parts.

[0015] In particular, the pouring unit 6 comprises mechanisms 7, for example ball valve mechanisms, which are inserted inside the neck 3 of the bottle 2 so as to prevent fraudulent refilling of the bottle 2.

[0016] Above the valve means 7 is fitted the actual pourer body 8. Connected to this pourer body 8 by a screw thread is a stopper 10 which encloses it externally and which performs the functions of a stopper 10 with its position 9 transverse to the axis X-X of the closure. All the components of the pouring unit 8 are integral with each other and advantageously this pouring unit 8 is locked to the body 3 of the bottle 2 both axially and in rotation in a manner well known to a person skilled in the art.

[0017] A tubular outer cap 11 is fitted above the stopper 10.

[0018] The cap 11 is made of plastics material, for example, and completely covers the stopper 10, and also the transverse portion 9 of this with the upper wall 12.

[0019] At said upper wall 12 of the cap 11, the stopper 10 and the cap 11 are locked in rotation by means of two respective knurled portions 13 and 14, one engaging in the other.

[0020] Moreover, still at the upper wall 12 of the cap 11, the stopper 10 and the cap 11 are locked axially by means of an internal annular projection 15 of the cap 11 which abuts against the lower part of the stopper 10.

[0021] Between the upper wall 12 and the lower end 16 of the cap 11 is fitted a breakable intermediate annular band 21.

[0022] This annular band 21 comprises a segment in

the form of a tab 21A, which is accommodated in a cut away area 22 in the body of the cap 11.

[0023] The annular band 21 is connected to the lower portion 16 of the cap 11 solely by means of the bridging pieces 23.

[0024] Provision is also made for a metal band 24 to enclose the cap 11 tightly at the breakable annular band 21. To anchor the metal band 24 firmly to the cap 11, an annular projection 25 is provided and an annular depression made in the cap, and the metal band 24 is moulded to these in its upper part.

[0025] Locked to the pouring unit 8 is a sleeve 17 of tubular shape which externally encloses the neck 3 of the bottle 2.

[0026] At the bottom, the metal band 24 is wrapped internally around the lower end of the cap 11 and of the sleeve 17. This metal band 24 may be applied to the cap 11 by rolling.

[0027] The sleeve 17 has a portion 17B rigidly connected to the pourer 8 and a free end 17A facing towards the collar 18; moreover, the sleeve 17 has a projecting portion 17C which is seated in a groove 3A in the neck 3, so as to provide firm locking of the sleeve 17 axially and a pair of knurled areas 17D and 17E, one engaging in the other so as to lock the sleeve 17 in rotation.

[0028] The collar 18 is made integral in rotation with the cap 11 by means of annular knurled areas 19 and 20, one engaging in the other.

[0029] Therefore, in the present form of embodiment, the collar 18 is located at the bottom between the base of neck 3 of the bottle 2 and the free end part. 17A of the sleeve 17.

[0030] In other words, the collar 18 is located in an axial direction, or parallel to the axis X-X, between the base of the neck of the bottle 2 and the end part of the sleeve 17, and in a longitudinal direction, or transversely to the axis X-X, between the outer cap 11 and the neck 3 of the bottle 2.

[0031] Moreover, axially, the collar 18 has a portion 18M of surface placed on top of the free end part 17A of the collar 17.

[0032] Because the metal band 24 and sleeve 17 are connected to each other, the result is that the collar 18 is firmly anchored to the sleeve 17 and therefore to the bottle 2.

[0033] Therefore the collar 18 is held in position by the cap 11, which secures said collar 18 against the free portion 17A of the sleeve 17.

[0034] In short, the cap 11 and the metal band 24 act as connecting means between the collar 18 and the sleeve 17.

[0035] With particular reference now to figure 1D, it may be noted how this collar 18 is made in the form of a ring, in particular a truncated cone-shaped ring.

[0036] In fact, this truncated cone-shaped ring 18 has an inner surface 18A and an outer surface 18B, and said inner surface 18A has a first cylindrical zone 18C and a second cylindrical zone 18D, the latter concentric with

the first and a third cylindrical zone 18I; said second cylindrical zone 18D has a smaller radius of circumference compared with the first cylindrical zone 18C, while said third cylindrical zone 18I has a radius of intermediate value compared with said first cylindrical zone 18C and said second cylindrical zone 18D.

[0037] The first cylindrical zone 18C and the second cylindrical zone 18D are connected to each other by means of a first inclined plane 18E so as to create a slope for purposes and requirements which will be described in more detail below. Similarly, said second cylindrical zone 18E is connected to said third cylindrical zone 18I by means of a second inclined plane 18L.

[0038] Said first inclined plane 18E and second inclined plane 18L are angled relative to the axis X-X of the neck 3 of the bottle 2 at a predefined angle.

[0039] For example this angle may assume angular values of between 30° and 60°.

[0040] In fact, as can be seen from figures 1B and 1C, at the planes 18E, 18D and 18L the collar 18 assumes a trapezoidal cross-section.

[0041] Provision is also made for the free lower portion 17A of the sleeve 17 to have an inclined plane while the collar 18 has instead a plane substantially transverse to the axis X-X of the neck of the bottle. Alternatively, the free lower end of the sleeve 17A and the collar 18 both have an inclined plane.

[0042] Referring once more to figure 1D, it will be noted that said inclined plane 18E has indicating means 18F which, in the specific form of embodiment, are in the form of a tooth having a flat upper surface 18G.

[0043] This tooth 18F faces towards the free portion 17A of the sleeve 17, or this tooth 18F abuts against the free end 17 of the sleeve 17.

[0044] The outer surface 18B provides indicating means 18H, which in the specific form of embodiment, are in the form of a projection; this projection is useful in the operations of fitting the collar 18 in that ensures correct centring of the ring relative to the rest of the closure device 1.

[0045] When an attempt is made to remove the closure 1 fraudulently with tools which can be inserted between the base of the neck of the bottle and the lower portion 16, such tools, for example a screwdriver, exert a thrust from the bottom upwards, or a thrust acting towards the mouth 4 of the neck 3 of the bottle 2.

[0046] The tools therefore impart a substantially axial movement to the closure 1.

[0047] Consequently, under the action of such tools, the collar 18 moves up onto the free end 17A of the sleeve 17, through the combined action of the tooth 18F (figure 1D) and the ramp 18E.

[0048] In fact, the tooth 18F abuts against the free portion 17A of the sleeve 17 and therefore functions as a fulcrum for the ring 18, while the ramp 18E acts as a slope assisting in unseating the ring 18 with respect to the sleeve 17.

[0049] In this way, the ring 18 partly moves up onto

the sleeve 17.

[0050] In the present form of embodiment, where the cap 11 is present, this will be broken or visibly damaged by the ring 18 which, being on top of the sleeve 17, acts as a wedge opening out the cap 11 until it breaks.

[0051] In this form of embodiment, the metal band 24 will also be broken by the wedge action applied by the ring 18.

[0052] In other words, the connection which is created between the ring 18, provided with the tooth 18F with a flat surface 18G, and the sleeve 17, causes the ring to move away from the centre once it is subjected to a thrust acting from the bottom upwards.

[0053] Moreover, the inclined ramp 18E assists the ring 18 in moving up onto the free portion 17A of the sleeve 17, so as to cause the cap 11 and the metal band 24 to break.

[0054] In fact, it should be noted, advantageously, that the sleeve 17 is produced from plastics materials having suitable deformation at the loads to which it is subjected, while the collar 18 is produced from plastics materials having a mechanical strength lower than that of the plastics materials of the sleeve 17.

[0055] In this way, by means of the invention, the user/purchaser will have an immediate visual indication of any attempt to tamper with the closure device.

[0056] Moreover, there is also the advantage that the closure 1 is even more difficult to reconstruct than known closures, since the cap 11 is split and reconstructing it would be impossible or at least more difficult and costly compared with reconstructing the tamper evident ring of closures known in the sector.

[0057] Referring to figure 2A, the number 30 indicates a closure not according to the invention, while the bottle, the upper part only of which is shown, is indicated by the number 31.

[0058] The bottle 31, conventional in itself, comprises a neck 32 of substantially cylindrical shape and having a mouth 33 and a body 34 connected externally to the neck 32.

[0059] The closure 30 comprises a pouring unit 35 of known type and which will therefore not be described below in detail, but only in its basic parts.

[0060] In particular, the pouring unit 35 comprises mechanisms 36, for example ball valve mechanisms, which are positioned inside the neck 32 of the bottle 31 so as to prevent it from being fraudulently refilled.

[0061] The actual pourer body 37 is fitted above the valve means.

[0062] All the components of the pouring unit 35 are integral with each other and advantageously this pouring unit 35 is locked to the neck 32 of the bottle 31 both axially and in rotation in a manner well known to a person skilled in the art.

[0063] Screwed onto the body of the pourer 37, by means of a screw connection 38, is a stopper 40 the closure end wall of which is indicated by the number 39.

[0064] The lower portion 44 of the closure 30 has an

annular band 45.

[0065] This annular band 45 in the upper portion 45A is connected to the pourer body 37 solely via an annular projection 46.

5 **[0066]** Locked to the pourer body 37 is a sleeve 47 of tubular shape which externally encloses the neck 32 of the bottle 31.

10 **[0067]** The sleeve 47 has a portion 47A rigidly connected to the pourer 37 and a free end 47B facing towards the base of the neck 32 of the bottle 31. In the form of figures 2a and 2b, this free end has a flat surface 47C substantially transverse to the axis X-X.

15 **[0068]** The sleeve 47 is locked in rotation to the neck 32 by means of annular knurled areas 48A and 48B, one engaging in the other, and is locked axially to the neck 32 of the bottle 31 by means of a groove 48C present in the neck 32 of the bottle 31.

20 **[0069]** With particular reference now to figure 2B, it will be noted that the annular band 45 has on its end portion 45B an inner surface 45C and an outer surface 45D. This inner surface 45C has a first cylindrical zone 45E and a second cylindrical zone 45F, the latter concentric with the first, and also a third cylindrical zone 45G. Said second cylindrical zone 45F has a smaller radius compared with that of the first cylindrical zone 45E and said third cylindrical zone 45G has a radius of intermediate value between that of said first cylindrical zone 45E and that of the second cylindrical zone 45F.

25 **[0070]** The first cylindrical zone 45E and the second cylindrical zone 45F are connected to each other by means of a first inclined plane 45H so as to create a slope, just as said second cylindrical zone 45F is connected to said third cylindrical zone 45G by means of a second inclined plane 45I.

30 **[0071]** Said first inclined plane 45H and second inclined plane 45I are placed at a predefined angle relative to the axis X-X of the neck 32.

[0072] For example, this angle may assume values of between 30° and 60°.

35 **[0073]** Provision is also made for the free lower portion 47B of the sleeve 47 to have an inclined plane while the annular band 45 may instead have a plane substantially transverse to the axis X-X of the neck 32 of the bottle 31.

40 **[0074]** Alternatively, the free lower end of the sleeve 47B and of the annular band 45 both have an inclined plane.

45 **[0075]** The sleeve 47 is therefore located axially, or parallel to the axis X-X, between the base of the neck of the bottle 31 and the inclined plane 45H of the end part 45B of the annular band 45 while in a radial direction, or transversely to the axis X-X, it is located between the annular band 45 and the neck 32 of the bottle 31.

50 **[0076]** When an attempt is made to remove the closure 30 from the neck of the bottle fraudulently with tools which can be inserted between the base of the neck of the bottle and the lower portion 44, such tools, for example a screwdriver, exert a thrust from the bottom upwards, or a thrust directed towards the mouth 33 of the neck 32 of the bottle

31.

[0077] The tools therefore impart to the closure 30 a substantially axial movement and therefore under the action of such tools, the annular band 45 moves up onto the free end 47B of the sleeve 47, by means of the inclined plane 45H, which causes radial movement of the band.

[0078] In the form of figures 2a and 2b, the annular connection 46 of the annular band 45 will be broken and also the annular band itself will be broken or visibly damaged.

[0079] In this way, the user/purchaser will have an immediate visual indication of any attempt to tamper with the closure device.

[0080] Moreover, there is also the advantage that the closure 30 is even more difficult to reconstruct than known closures, since the annular band 45 remains split and reconstructing it would be impossible or at least more difficult and costly compared with reconstructing the tamper evident ring of previous closures.

[0081] Now, considering in particular the form of embodiment shown in figures 3A-3B, it will be noted that the closure according to the invention, indicated as a whole by the number 50, is placed on a bottle, only the upper part 51 of which is shown, having a neck 52, of substantially cylindrical shape. The bottle has a mouth 53 and a base area 54 of the neck 52.

[0082] The closure 50 also comprises a pouring unit 55 of known type and which will therefore not be described below in detail, but only in its basic parts.

[0083] In particular, the pouring unit 55 comprises valve components 56 of the ball type, inserted inside the neck 52 so as to prevent fraudulent refilling of the bottle 51.

[0084] The actual pourer body 57 is fitted above the valve means 56. Connected to this pourer body 57, by threaded means, known in themselves, is a stopper 58. All the components of the pouring unit 55 are integral with each other and advantageously the pourer body 57 is locked to the neck 52 of the bottle 51 both axially and in rotation in a manner well known to a person skilled in the art.

[0085] A cap 59, produced for example from plastics material, entirely covers the stopper 58.

[0086] At its transverse wall 60, the cap 59 and the stopper 58 are locked in rotation by means of respective knurled portions 61, one engaging in the other, known in themselves.

[0087] Moreover, still at the upper wall 60 of the cap 59, the stopper 58 and the cap 59 are locked axially by means of internal annular projections 62, known in themselves.

[0088] The closure 50 also has a lower portion 63 which comprises a tubular band 64 capable of tightly enclosing a sleeve 65 underneath it, the sleeve being of tubular shape, connected in a known manner to the pourer body 57.

[0089] The sleeve 65 externally encloses the neck 52 of the bottle 51 and is locked in rotation to the neck 52

by means of annular knurled areas 66 and 67 (figure 3B), one engaging in the other. The sleeve 65 is locked axially by means of an annular lip 68 which is seated in a groove 69 in the neck 52.

5 **[0090]** The sleeve 65 also has an upper portion 65A rigidly connected to the tubular band 64 and to the pourer body 57. A free end 65B faces towards anti-prizing means 70. In the present form of embodiment, this free end has a flat surface 65C placed substantially in a position trans-
10 versely to the axis X-X.

[0091] The tubular band 64 is therefore anchored to the sleeve 65 by means of a first fold 64A made at the upper end of the band 64.

15 **[0092]** This fold 64A is obtained, for example, by means of a rolling operation.

[0093] The tubular band 64, preferably of metal sheet, is folded at the bottom over the lower end of said anti-prizing means 70 by means of a second fold 64B.

20 **[0094]** In the present form of embodiment, too, the anti-prizing means 70 are positioned at the bottom between the base of the neck 52 of the bottle 51 and the end portion 65B of the sleeve 65.

[0095] These anti-prizing means 70 are made in the form of a ring and have an inner surface 70A and an outer surface 70B, where said inner surface 70A has a cylindrical zone 70C connected to the upper end of the anti-prizing means 70 by means of an inclined plane 70D, so as to create an inclined plane for purposes and requirements which will be described in more detail below.

25 **[0096]** The inclined plane 70D is positioned at a pre-defined angle relative to the axis X-X of the neck 52 of the bottle 51.

[0097] For example, this angle may assume values of between 30° and 60°.

30 **[0098]** When an attempt is made to remove the closure 50 fraudulently with tools which can be inserted at the base of the neck of the bottle, under the fold 64B of the band 64, such tools, for example a screwdriver, exert a thrust from the bottom upwards, or impart a substantially
40 axial movement to the closure 50.

[0099] Therefore under the action of such tools, the anti-prizing means 70 move up onto the end portion 65B of the sleeve 65, owing to the presence of the inclined plane 70D.

45 **[0100]** In the present form of embodiment, where the tubular band 64 is present, the latter will be broken or visibly damaged by the ring 70 which, once it is on top of the sleeve 65, acts as a wedge opening out the sleeve 65 and the tubular band 64 until the latter breaks.

50 **[0101]** In this way, by means of the invention, the user/purchaser will have an immediate visual indication of any attempt to tamper with the closure.

[0102] Referring now to the form of embodiment shown in figures 4A-4B, in which the elements already described have been assigned identical numbers, it will be noted that the closure according to the invention is indicated as a whole by the number 80, while the bottle, the upper part only of which is shown, is indicated by the number 51.

[0103] The closure 80 is such that its lower portion 63 comprises a sleeve 65 of tubular shape, connected to the pourer body 57.

[0104] The sleeve 65 moreover externally encloses the neck 52 of the bottle 51.

[0105] The sleeve 65 is also locked in rotation to the neck 52 of the bottle 51 by means of the annular knurled areas 66 and 67, one engaging in the other, while it is locked axially by means of the annular lip 68 which is seated in the groove 69 in the neck 52.

[0106] The sleeve 65 has its upper portion 65A connected to the pourer body 57 and also has its free end 65B facing towards anti-prizing means 70.

[0107] It should be noted that in the present form of embodiment, the anti-prizing means 70 are located at the bottom between the base 54 of the neck 52 of the bottle 51 and the end portion 65B of the sleeve 65.

[0108] In this form of embodiment, too, the anti-prizing means 70 are made in the form of a ring and have the inner surface 70A and an outer surface 70B, where said inner surface 70A has a cylindrical zone 70C connected to the upper end of the anti-prizing means 70 by means of an inclined plane 70D, so as to create a slope for purposes and requirements which will be described in more detail below.

[0109] The inclined plane 70D is positioned relative to the axis X-X of the neck 52 of the bottle 51 at a predefined angle.

[0110] For example, this angle may assume values of between 30° and 60°.

[0111] It should be noted that in the present form of embodiment, the anti-prizing means 70 are located axially, or parallel to the axis X-X, between the base 54 of the neck of the bottle and the end part of the sleeve 65.

[0112] In this form of embodiment, the anti-prizing means 70 are held in the position described above by connecting elements 81, which function as connecting means between the sleeve 65 and the anti-prizing means 70. In particular, the connecting elements 81 may be spot welds or may be constituted by adhesive strips which are broken when the anti-prizing means 70 move up onto the sleeve 65.

[0113] Therefore, when an attempt is made to remove the closure 80 fraudulently with tools which can be inserted between the base of the neck of the bottle, these tools, for example a screwdriver, exert a thrust from the bottom upwards, or impart to the closure 80 a substantially axial movement. Consequently, under the action of such tools, the anti-prizing means 70 move up onto the end portion 65B of the sleeve 65, owing to the presence of the inclined plane 70D.

[0114] In this way, by means of the invention, the user/purchaser will have an immediate visual indication of any attempt to tamper with the closure device.

[0115] From what has been described, it is concluded that all closures produced in accordance with the invention are difficult to reconstruct since, after they have been tampered with, there are visible breaks of many compo-

nent parts.

[0116] Clearly, a person skilled in the art, for the purpose of meeting incidental and specific requirements, will be able to make numerous changes and produce numerous variants to the closures described above, without thereby departing from the scope of the invention as defined in the following claims.

10 Claims

1. A tamper evident closure for a bottle, particularly for a bottle suitable for containing valuable drinks,

- said bottle (2, 51) having a neck (5, 54) which extends axially along the longitudinal axis (X-X) of the bottle (2, 51) from its base by which it is connected to the body of the bottle;

- said neck (5, 54) having an opening (7, 56) at its free end;

- said closure comprising means of stoppering (11, 59) said opening of said neck (5, 54) and being connected by means of a threaded connection to a pouring unit (6, 55);

- said pouring unit (6, 55) being connected to a sleeve (17, 65) arranged axially along the outer surface of said neck (5, 54);

- annular means (18, 70) arranged between the base of said neck (5, 54) and the lower end of the sleeve (17A, 65B);

- said annular means (18, 70) and said lower end (17A, 65B) of said sleeve (17, 65) having respective surfaces (11A, 18E, 65C, 70D) facing towards each other; **characterised in that** said annular means are connected by breakable connecting means (24, 64, 81) to said sleeve (17, 65);

- at least one of said facing surfaces (11A, 18E, 65C, 70D) of said annular means (18, 70) and of said lower end (17A, 65B) being inclined relative to the longitudinal axis (X-X) of the neck (5, 54), so that, as a result of an axial movement of said annular means (18, 70) towards said opening in said neck (5, 54), breakage of said breakable means (24, 64, 81) occurs and a consequent radial movement of at least one circumferential zone of said annular means (18, 70).

2. A tamper evident closure according to claim 1, **characterised in that** at least one of said surfaces (11A, 18E; 65C, 70D) is inclined relative to the longitudinal axis (X-X) by angular values within a range of between 30° and 60°.

3. A tamper evident closure according to claim 1, **characterised in that** said breakable connecting means (24, 64, 81) are an annular band.

4. A tamper evident closure for bottles according to claim 1, **characterised in that** said breakable connecting means (24, 64, 81) are an adhesive.
5. A tamper evident closure for bottles according to claims 3 and 4, **characterised in that** said annular means (18, 70) have a trapezoidal cross-section.
6. A tamper evident closure for bottles according to claim 1, **characterised in that** said breakable connecting means (24, 64, 81) are an annular projection.

Patentansprüche

1. Originalitätsverschluss für eine Flasche, insbesondere für eine zur Aufnahme wertvoller Getränke geeignete Flasche,

- wobei die Flasche (2, 51) einen Hals (5, 54) aufweist, der sich axial entlang der Längsachse (X - X) der Flasche (2, 51) von seinem Fuß erstreckt, mit dem er mit dem Körper der Flasche verbunden ist;

- wobei der Hals (5, 54) eine Öffnung (7, 56) an seinem freien Ende aufweist;

- wobei der Verschluss ein Mittel zum Zustöpseln (11, 59) der Öffnung des Halses (5, 54) aufweist und mittels einer Schraubverbindung mit einer Ausgießeinheit (6, 55) verbunden ist;

- wobei die Ausgießeinheit (6, 55) mit einer Hülse (17, 65) verbunden ist, die axial entlang der Außenfläche des Halses (5, 54) angeordnet ist;

- wobei ein ringförmiges Mittel (18, 70) zwischen dem Fuß des Halses (5, 54) und dem unteren Ende der Hülse (17A, 65B) angeordnet ist;

- wobei das ringförmige Mittel (18, 70) und das untere Ende (17A, 65B) der Hülse (17, 65) jeweilige Oberflächen (11A, 18E, 65C, 70D) aufweisen, die einander zugewandt sind;

dadurch gekennzeichnet, dass

- das ringförmige Mittel durch ein brechbares Verbindungsmittel (24, 64, 81) mit der Hülse (17, 65) verbunden ist;

- wenigstens eine der zugewandten Oberflächen (11A, 18E, 65C, 70D) des ringförmigen Mittels (18, 70) und des unteren Endes (17A, 65B) relativ zu Längsachse (X - X) des Halses (5, 54) geneigt ist, so dass als Resultat einer axialen Bewegung des ringförmigen Mittels (18, 70) in Richtung der Öffnung in dem Hals (5, 54) ein Bruch des brechbaren Mittels (24, 64, 82) und eine sich ergebende, radiale Bewegung wenigstens einer Umfangszone des ringförmigen Mittels (18, 70) auftritt.

2. Originalitätsverschluss gemäß Anspruch 1, **dadurch gekennzeichnet, dass** wenigstens eine der Oberflächen (11A, 18E; 65C, 70D) relativ zu Längsachse (X - X) um Winkelwerte aus einem Bereich zwischen 30° und 60° geneigt ist.

3. Originalitätsverschluss gemäß Anspruch 1, **dadurch gekennzeichnet, dass** das brechbare Verbindungsmittel (24, 64, 81) ein ringförmiges Band ist.

4. Originalitätsverschluss für Flaschen gemäß Anspruch 1, **dadurch gekennzeichnet, dass** das brechbare Verbindungsmittel (24, 64, 81) ein Klebstoff ist.

5. Originalitätsverschluss für Flaschen gemäß den Ansprüchen 3 und 4, **dadurch gekennzeichnet, dass** das ringförmige Mittel (18, 70) einen trapezförmigen Querschnitt aufweist.

6. Originalitätsverschluss für Flaschen gemäß Anspruch 1, **dadurch gekennzeichnet, dass** das brechbare Verbindungsmittel (24, 64, 81) ein ringförmiger Vorsprung ist.

Revendications

1. Dispositif de fermeture inviolable pour une bouteille, en particulier pour une bouteille adaptée pour contenir des boissons de valeur,

- ladite bouteille (2, 51) ayant un goulot (5, 54) qui s'étend axialement le long de l'axe longitudinal (X-X) de la bouteille (2, 51) depuis sa base par laquelle elle est reliée au corps de la bouteille ;

- ledit goulot (5, 54) ayant une ouverture (7, 56) à son extrémité libre ;

- ladite fermeture comprenant un moyen pour boucher (11, 59) ladite ouverture dudit goulot (5, 54) et étant reliée par une connexion fileté à une unité de coulée (6, 55) ;

- ladite unité de coulée (6, 55) étant reliée à un manchon (17, 65) agencé axialement le long de la surface externe dudit goulot (5, 54) ;

- un moyen annulaire (18, 70) agencé entre la base dudit goulot (5, 54) et l'extrémité inférieure du manchon (17A, 65B) ;

- ledit moyen annulaire (18, 70) et ladite extrémité inférieure (17A, 65B) dudit manchon (17, 65) ayant des surfaces respectives (11A, 18E, 65C, 70D) se faisant face ; **caractérisé en ce que** ledit moyen annulaire est relié par un moyen

- de connexion cassable (24, 64, 81) audit manchon (17, 65) ;
- au moins une desdites surfaces se faisant face (11A, 18E, 65C, 70D) dudit moyen annulaire (18, 70) et de ladite extrémité inférieure (17A, 65B) étant inclinée par rapport à l'axe longitudinal (X-X) du goulot (5, 54), de sorte, que suite à un mouvement axial dudit moyen annulaire (18, 70) vers ladite ouverture dans ledit goulot (5, 54), la rupture dudit moyen cassable (24, 64, 82) se produit en un mouvement radial consécutif d'au moins une zone circonférentielle dudit moyen annulaire (18, 70).
- 5
- 10
2. Dispositif de fermeture inviolable selon la revendication 1, **caractérisé en ce qu'**au moins une desdites surfaces (11A, 18E ; 65C, 70D) est inclinée par rapport à l'axe longitudinal (X-X) par des valeurs angulaires comprises dans une plage entre 30° et 60°.
- 15
- 20
3. Dispositif de fermeture inviolable selon la revendication 1, **caractérisé en ce que** ledit moyen de connexion cassable (24, 64, 81) est une bande annulaire.
- 25
4. Dispositif de fermeture inviolable pour bouteilles selon la revendication 1, **caractérisé en ce que** ledit moyen de connexion cassable (24, 64, 81) est un adhésif.
- 30
5. Dispositif de fermeture inviolable pour bouteilles selon les revendications 3 et 4, **caractérisé en ce que** ledit moyen annulaire (18,70) a une section trapézoïdale.
- 35
6. Dispositif de fermeture inviolable pour bouteilles selon la revendication 1, **caractérisé en ce que** ledit moyen de connexion cassable (24, 64, 81) est une saillie annulaire.
- 40

45

50

55

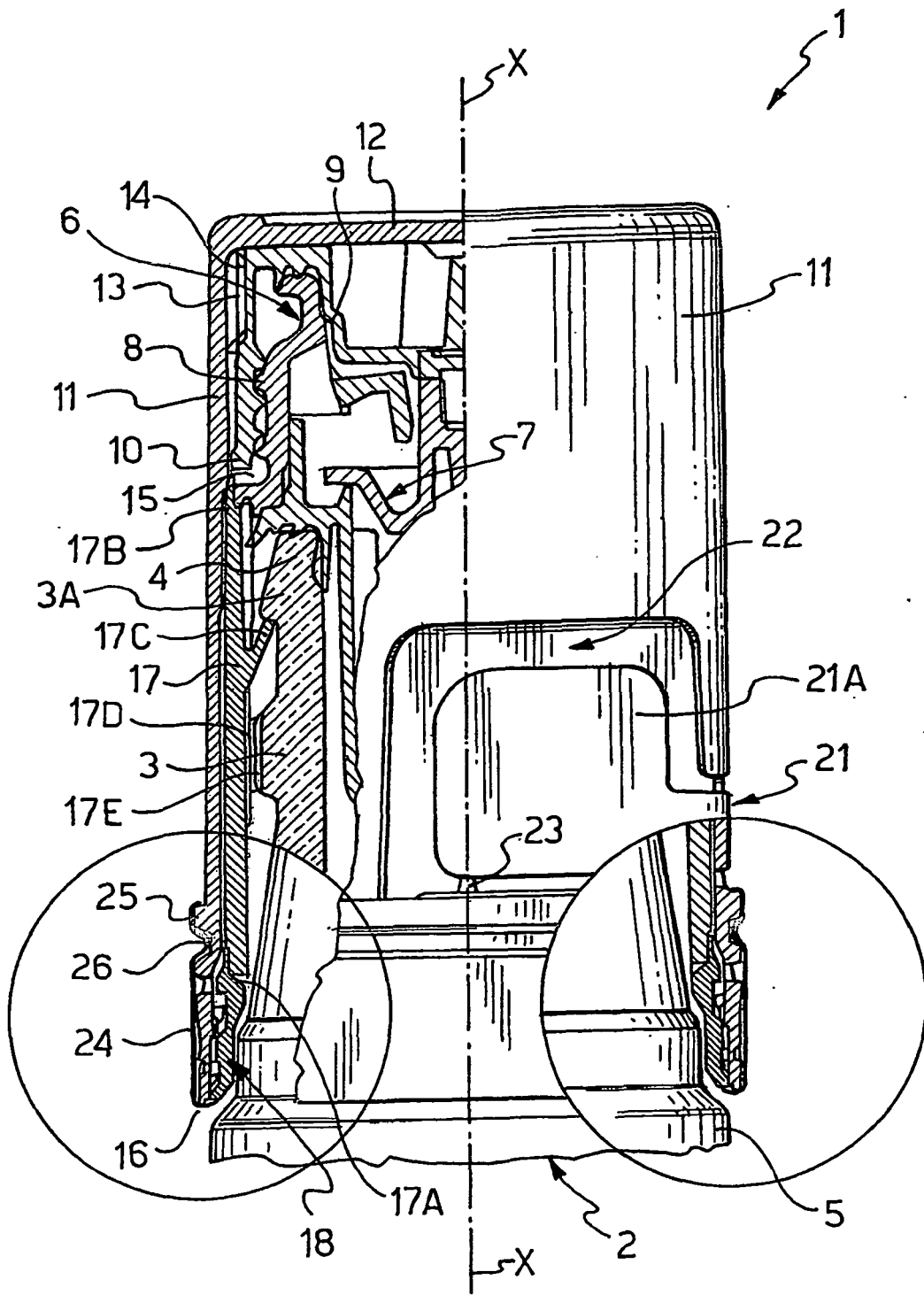
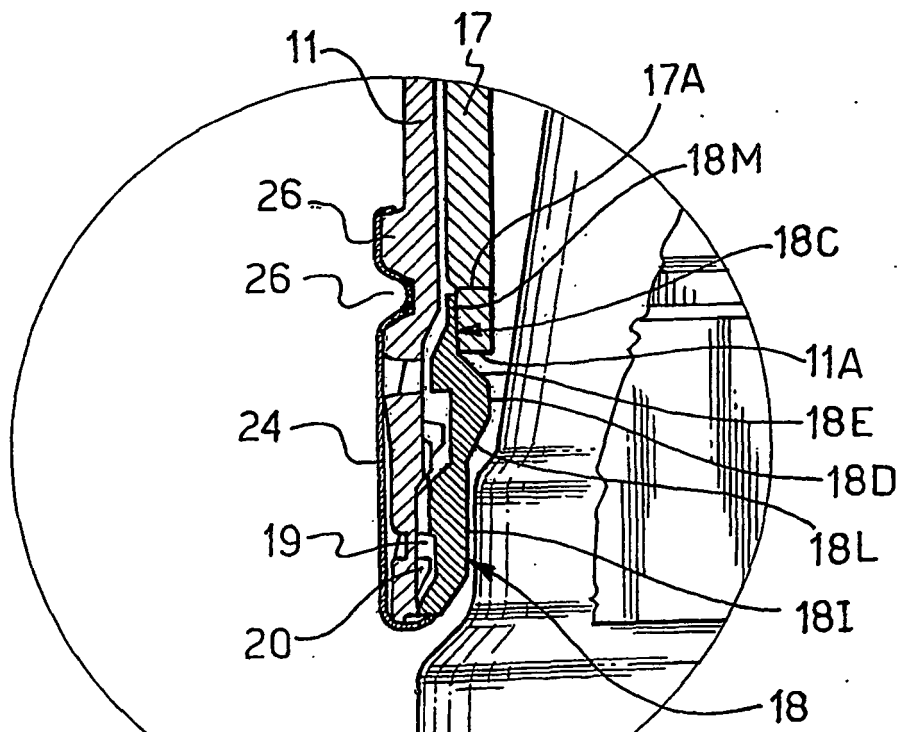
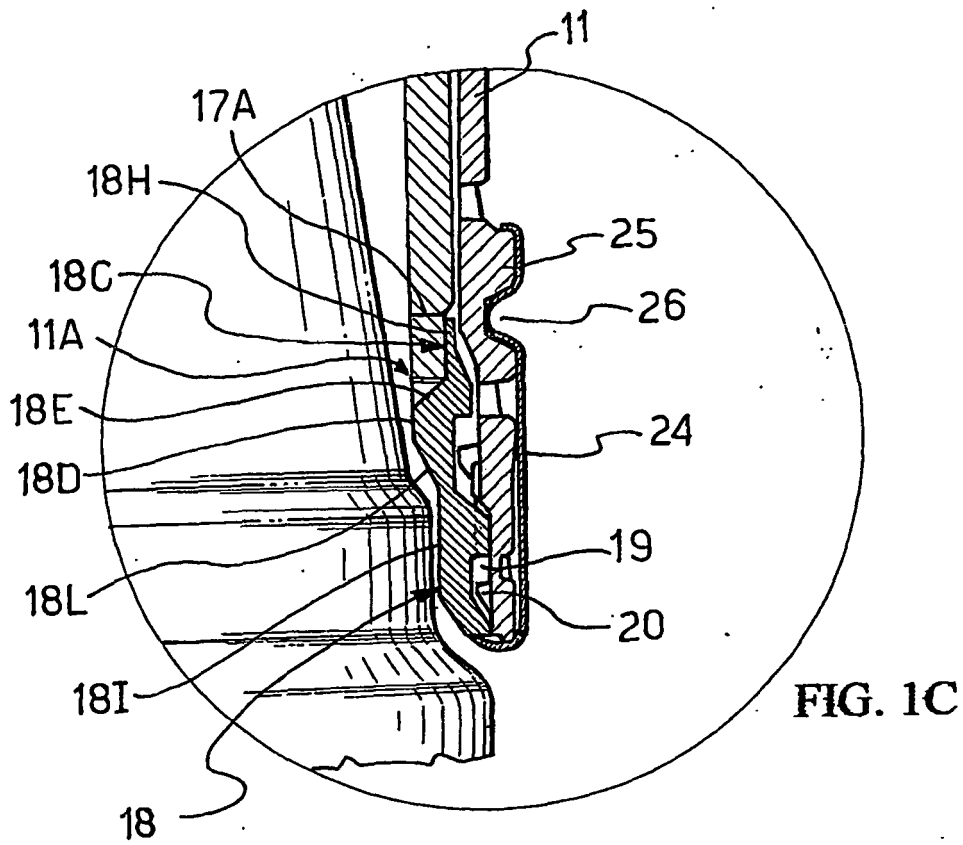

FIG. 1A



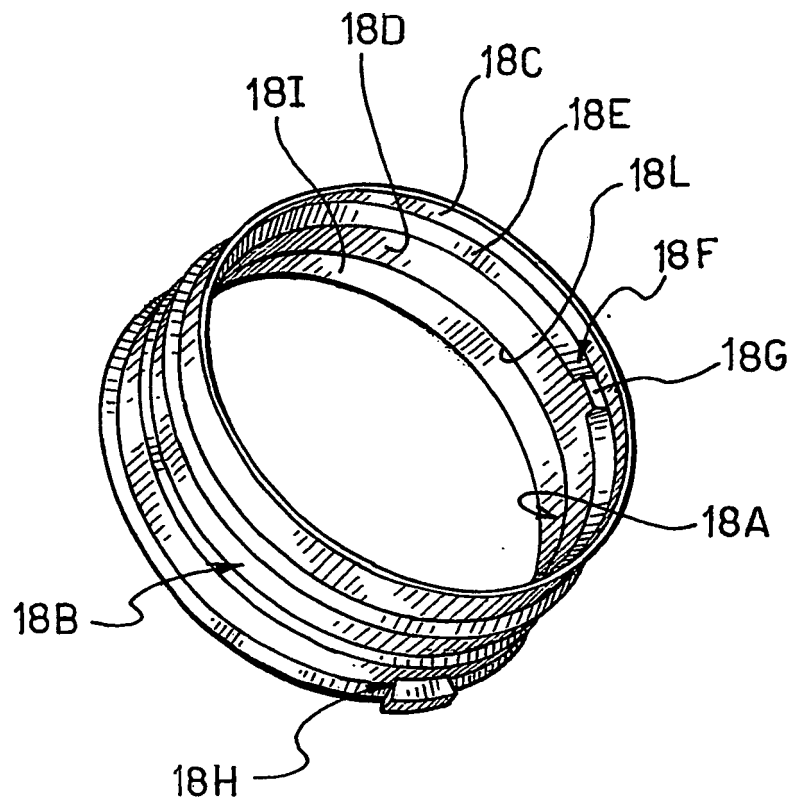

FIG. 1D

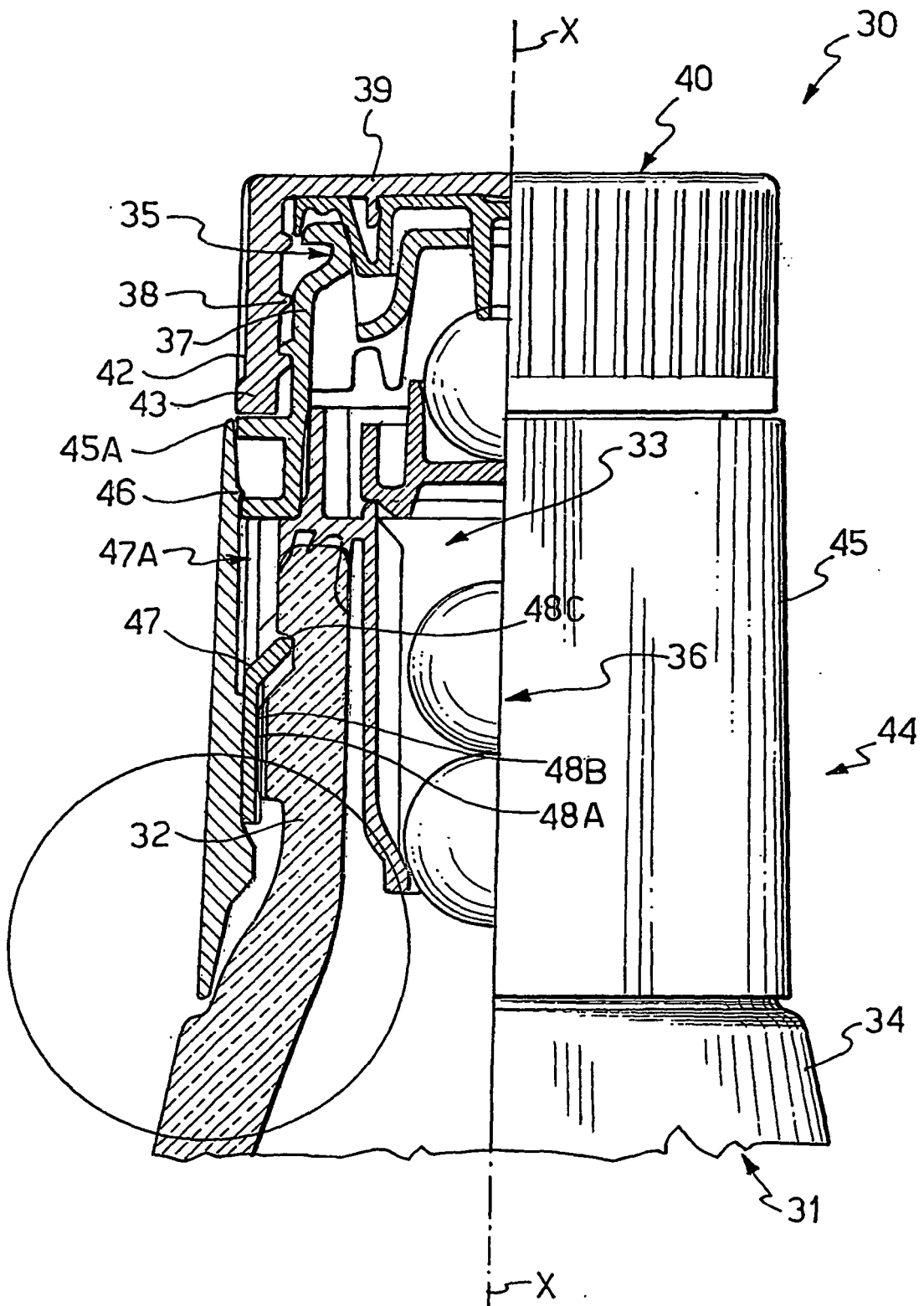

FIG. 2A

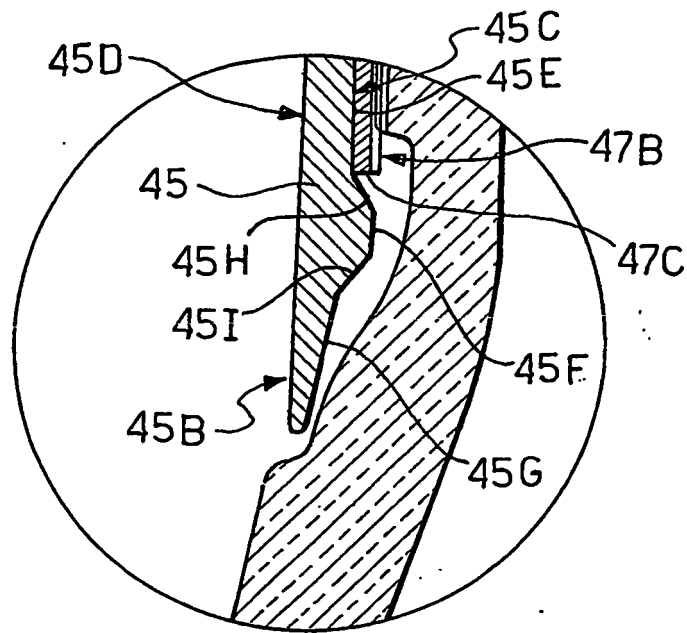

FIG. 2B

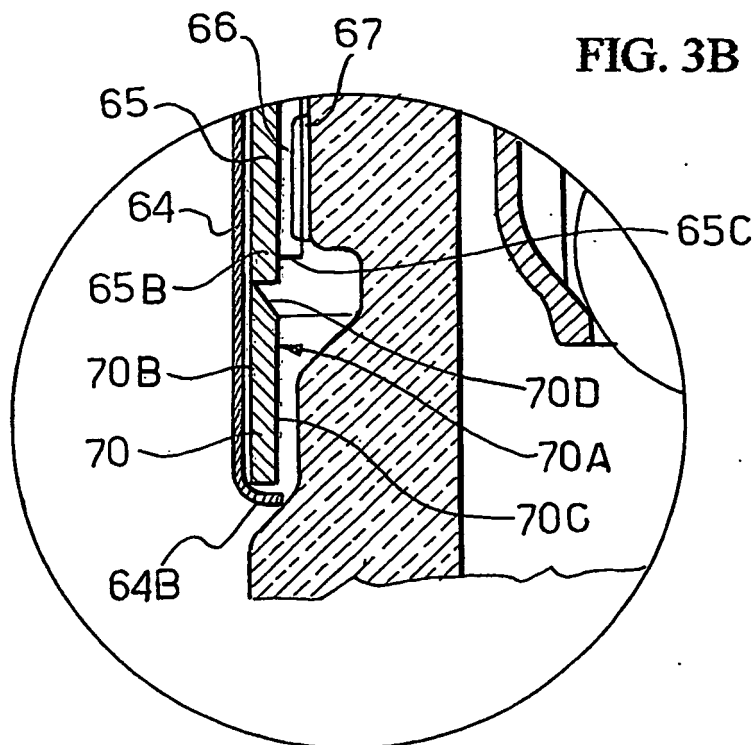

FIG. 3B

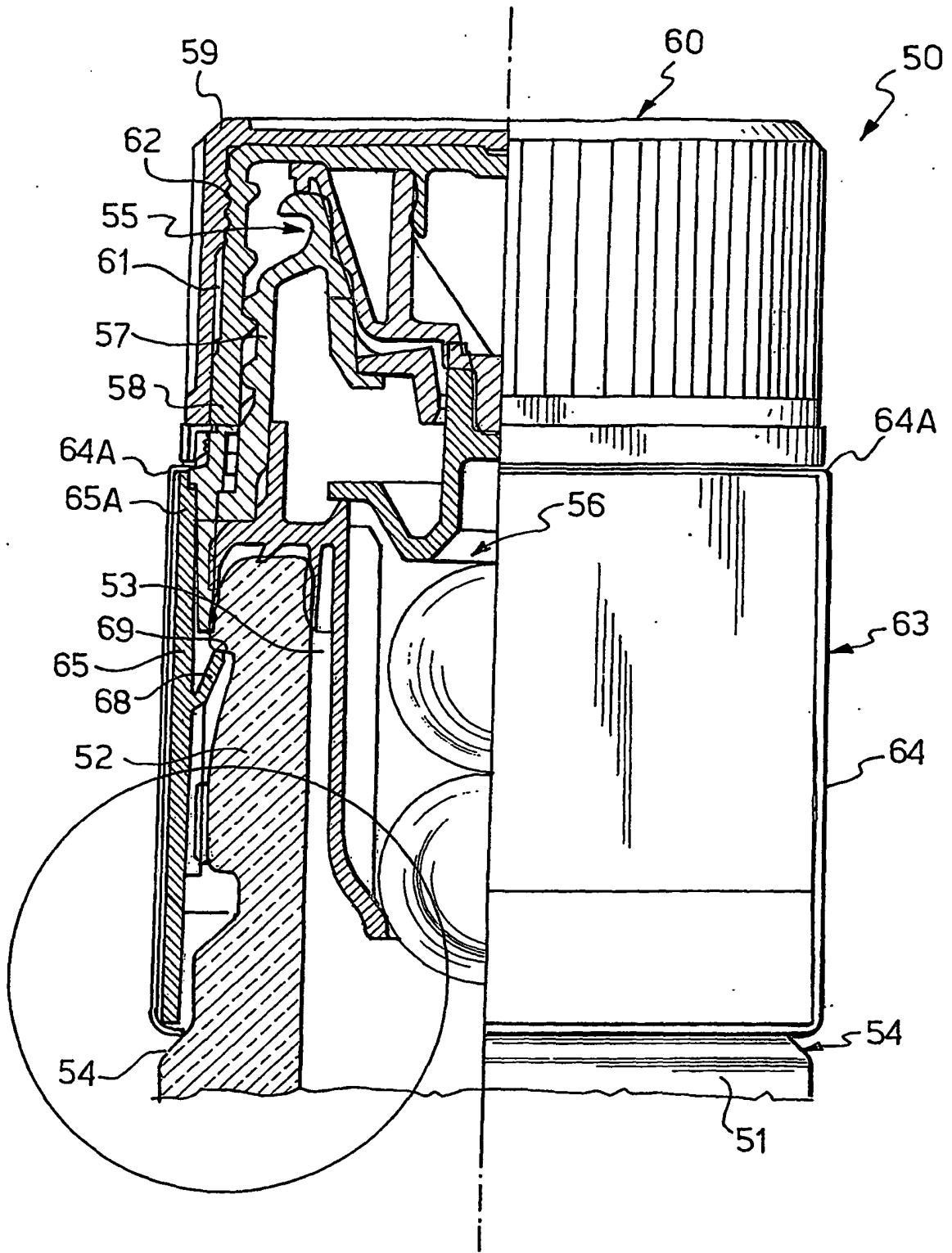
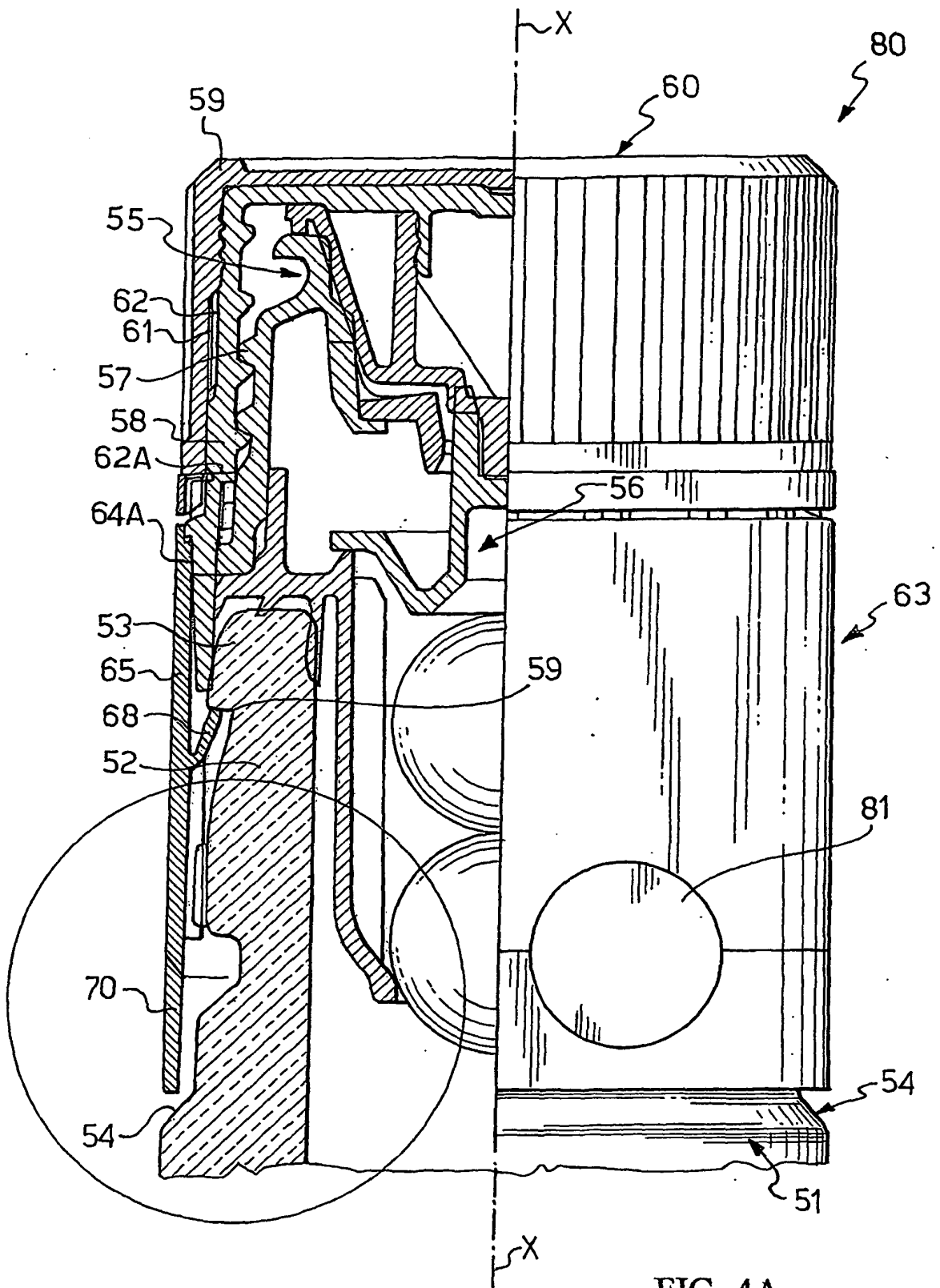

FIG. 3A



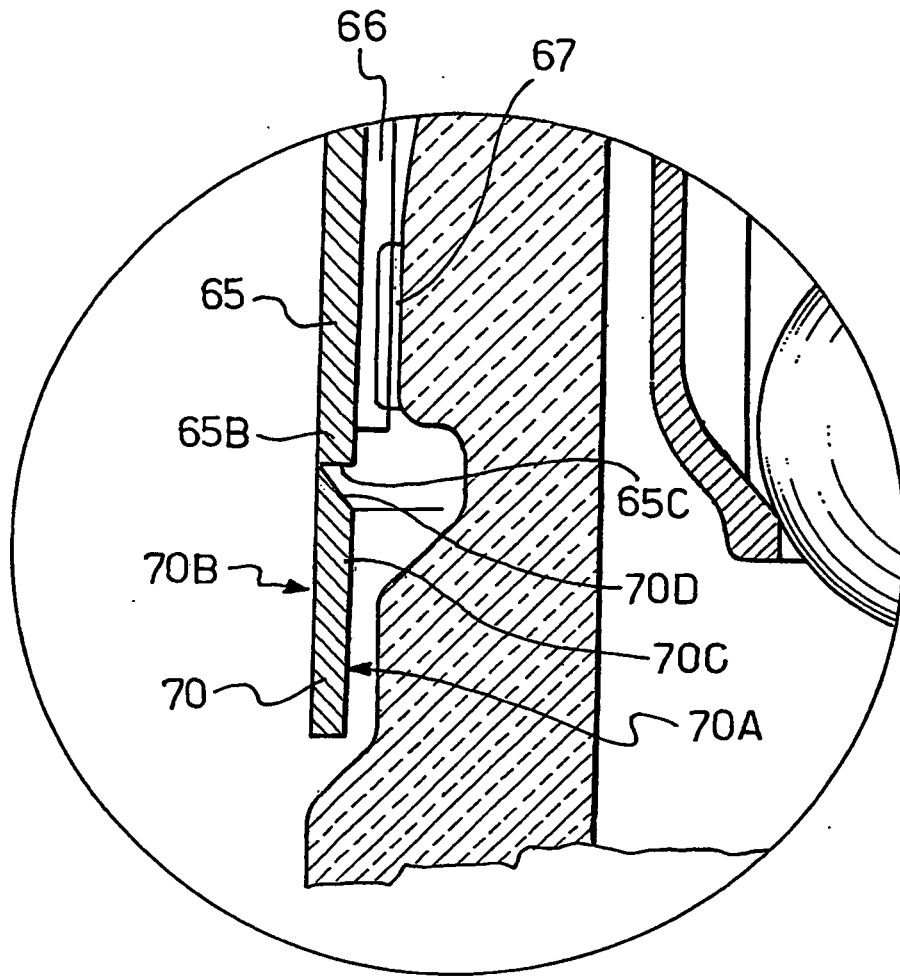

FIG. 4B