

**EUROPEAN PATENT APPLICATION**

Application number: 83306220.1

Int. Cl.<sup>3</sup>: G 06 F 15/24, G 09 F 27/00

Date of filing: 13.10.83

Priority: 14.10.82 US 434434

Applicant: **ByVideo, Inc., 225 Humboldt Court, Sunnyvale California 94086 (US)**

Date of publication of application: 23.05.84  
Bulletin 84/21

Inventor: **Bushnell, Nolan Kay, 3860 Woodside Road, Woodside California 94062 (US)**  
 Inventor: **Delman, Howard D., 415 South 12th Street, San Jose California 95112 (US)**  
 Inventor: **Dexter, Douglas V., 18982 Newton, Santa Ana California 92705 (US)**  
 Inventor: **Hector, Roger Donald, 3648 Deedham Drive, San Jose California 95148 (US)**  
 Inventor: **Dexter, Edward David, 245 South 17th Street, San Jose California 95112 (US)**  
 Inventor: **Wallace, Kurt F., 42 West Summit, Redwood City California 94062 (US)**

Designated Contracting States: **AT CH DE FR GB IT LI LU NL SE**

Representative: **Tomlinson, Kerry John et al, Frank B. Dehn & Co. European Patent Attorneys Imperial House 15-19 Kingsway, London WC2B 6UZ (GB)**

**Video display system for marketing items.**

A video terminal for marketing items including a video disc player 16 and video disc 18 for storing video and audio about the items, a video display 24 and audio amplifier 32 to communicate this information to a user of the terminal, a sonar detector 40, which detects the proximity of the user and a credit card reader 42, which detects a credit card, for fully activating the terminal, a keyboard 46 for entering item order information such as user name, and a data processor 50 to control the terminal. Also included is a unique video switch and character generator 26 for displaying text on the video display 24.

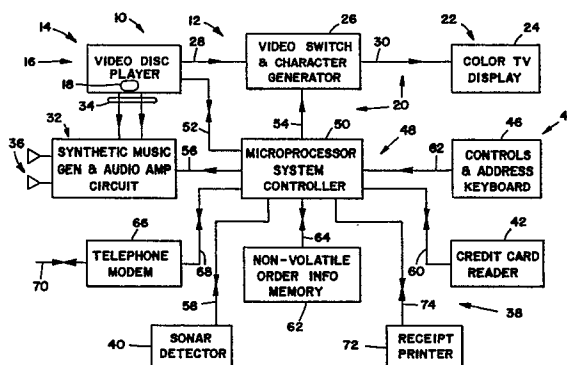

- 1 -  
TITLE MODIFIED  
see front page

Video Display System

Technical Field

This invention relates to apparatus for marketing items and, more particularly, to video display systems for displaying and selling various items.

Background Art

Constantly changing marketing techniques and devices are being created to take advantage of developing high-technology innovations with the intent of making it easier and less time-consuming for consumers to be informed of and purchase items. For example, video display systems are utilized in department stores for advertising for sale a variety of consumer products. The video systems have a video display, a video disc and a video disc player that can be activated by a consumer. The video disc has prestored video information which is retrieved by the video disc player and then displayed on the video display. The prestored video information can include video picture information for displaying pictures of the products that are for sale and pricing information associated with each of the products. A consumer can operate the video display system to view the products and their prices, complete a separate order form for desired products and then give the order form together with the purchase price, either using cash or a credit card, to a department store salesperson.

While the prior video display systems do make advantageous use of the high-technology innovations for marketing products, they are not highly efficient. For example, the pricing information, being prestored permanently on the video disc, cannot be changed to reflect current prices. Furthermore, the prior video display systems, when displaying still or freeze frames of pictures of products, do not have accompanying sounds that can assist the consumer in the product selection process. Also, the need to complete and deliver to the salesperson an order form is relatively time consuming, particularly if there are waiting lines at the purchase order counter. Moreover, the video display systems can be activated by anyone, such as children who might not be capable of ordering any products but who might play with the systems.

In another aspect concerning video display systems in general, broadcast standards define all the timing relationships for displaying video information on CRT displays. Thus, if in addition to TV pictures, textual data such as pricing information is to be simultaneously displayed on the display, precise timing relationships must be maintained between the two types of information. This normally requires sophisticated and expensive electronics equipment. Moreover, if the source of the video signals is a video disc, this can present timing problems. That is, the stored video signals, which include the conventional horizontal and vertical synchronization signals, may not precisely satisfy the standards from one

display or scan line to another because of, for example, differing speeds of rotation of the video disc.

5 The present invention is directed to overcoming the above and other problems of the prior art.

Disclosure of the Invention

10 In one aspect, the invention includes apparatus for marketing items, comprising means for providing information about the items, means for communicating the information to a user, means for sensing predetermined conditions, means for ordering the items and data processing means for controlling the providing means and the  
15 communicating means to communicate a portion of the information in response to the absence of the predetermined conditions and to communicate an additional portion of the information in response to one of the sensed predetermined conditions and  
20 to communicate all of the information in response to another of the sensed predetermined conditions and to control the ordering of the items.

25 In prior video display systems, sound information accompanying a freeze frame display of product information is not produced and pricing information accompanying the product information cannot be changed. In addition, orders cannot be entered and anyone can activate the display systems. In the present invention, the  
30 information communicated to a user can be easily updated with the current pricing information and sound can accompany the picture information. Furthermore, purchase orders can be entered by the

user and only those users who have, for example, credit cards which can be sensed or read, can activate the apparatus to communicate all the stored information to the prospective purchaser.

5           In another aspect, the invention includes apparatus for controlling the display of first and second information on a display, comprising means for generating first timing signals to control the display of the first  
10 information on the display, the first timing signals being susceptible to variations in timing, and means for generating second timing signals to control the display of the second information on the display in response to the first timing  
15 signals.

Prior video display systems have the timing relationship of displayed information precisely set by the broadcast standard, but this presents a problem if the signal varies  
20 from scan-line to scan-line. While complicated and expensive equipment can be utilized to overcome this problem, the present invention accepts this variation by employing simple and inexpensive equipment to produce the second timing  
25 signals which are derived from the first timing signals that correspond to the horizontal and vertical synchronization signals.

An embodiment of the invention will now be described by way of example and with reference to the  
30 accompanying drawings.

Brief Description of the Drawings

Fig. 1 is a block diagram of a video display system according to the present invention.

35 Fig. 2 shows pictorially one type of video terminal embodying the invention of Fig. 1.

Figs. 3A - 3E are flow charts used to

explain the operation of the terminal.

Fig. 4A and Fig. 4B are timing diagrams used to explain a video switch and character generator of the terminal.

5 Fig. 5 illustrates a block diagram of the video switch and character generator circuit of the terminal.

10 Fig. 6 is a detailed illustration of a screen location counter circuit used in the circuit of Fig. 5.

Detailed Description

Fig. 1 illustrates an apparatus or system 10 for marketing items and, in particular, a video display terminal 12 that can be used or  
15 operated by a consumer to view, select and order desired items. Video display terminal 12 includes a means 14 for providing information about the items. Specifically, means 14 can be a video disc  
20 player 16 which plays a video disc 18 that stores video information and sound information. The video information stored on video disc 18 has, as will be further described, listings and pictures of a variety of products that might be purchased by a consumer. The sound information stored on  
25 video disc 18, among other things, describes the products that can be purchased.

Video display terminal 12 also has a means 20 for communicating the information stored on the video disc 18. Means 20 includes a display  
30 22, such as a color TV display 24, which receives video information from video disc 18 via a video switch and character generator 26 which is coupled to each over an input line 28 and output line 30.

As will be further described, video switch and character generator 26, in addition to switching the video information from video disc 18 to display 24, generates character data that can be superimposed on the pictures being shown on display 24.

Means 20 for communicating information to a user of video display terminal 12 also includes a synthetic music generator and audio amplifier circuit 32 which is coupled to video disc player 16 via lines shown generally at 34. Circuit 32 also has speakers 36. Video disc 18, as previously mentioned, stores sound information describing the products displayed on display 24 and this sound information is coupled over lines 34 to circuit 32 to be heard by the user. As will be further described, circuit 32 can also be controlled to generate synthetic music.

Video display terminal 12 further has a means 38 for sensing predetermined conditions, including a sonar detector 40 which detects the proximity of a user to the video display terminal 12 and a credit card reader 42 which reads a credit card of a user for detection purposes. In the absence of detection of a user by sonar detector 40, video display terminal 12 will be in an attract mode in which no sound is produced by circuit 32 and certain attract mode pictures will be shown by display 24. Then, should a user approach sonar detector 40, video display terminal 12 will be switched into an initial mode in which audio will be heard via circuit 32 giving to the user information about the use of the machine and other matters. Then, should the user be

interested in viewing the products that can be  
ordered in the manner to be described, the user  
will insert a credit card in reader 42, which will  
activate terminal 12 to a play mode so that the  
5 information stored on video disc 18 can be  
conveyed to the user. Credit card reader 42 can  
be a magnetic stripe reader or an optical  
character reader to read the credit card number of  
the user.

10 A means 44 for ordering a desired  
product is included in the overall video display  
terminal 12. The ordering means 44, for example,  
constitutes a control and address keyboard 46 that  
can be manipulated by the user. In response to  
15 instructions for ordering products, which  
instructions will appear on display 24, the user  
can manipulate the keyboard 46 to enter order data  
such as user name and address, and product  
identification codes. Terminal 12 will already  
20 have the credit card number of the user, which  
will be acquired via credit card reader 42 as  
mentioned above. Further, keyboard 46 has  
controls, as will be further described, that  
enable the user to call up on display 24 products  
25 that are of interest.

Another component of video display  
terminal 12 is a data processing means 48 for  
performing various control functions under  
software control, as will be described. Data  
30 processing means 48 can be, for example, a  
microprocessor-based controller 50 which controls  
or receives data inputs from video disc player 16  
via a bidirectional line 52, video switch and  
character generator 26 via a line 54, synthetic



music generator and audio amplifier circuit 32 via  
a line 56, sonar detector 40 via a bidirectional  
line 58, credit card reader 42 via a line 60, and  
keyboard 46 via a line 62. As one specific  
5 example, microprocessor system controller 50 has  
memory (not shown) which stores digital data that  
are outputted on line 56 to cause circuit 32 to  
produce synthetic music during various times in  
the display of products.

10 Video display terminal 12 also has a non-  
volatile order information memory 62, under  
control by controller 50 via a line 64, that  
stores all orders that are placed by consumers  
using the terminal 12. A telephone modem 66 is  
15 coupled to controller 50 via a bidirectional line  
68 and interfaces with a remote central computer  
system (not shown) via a bidirectional line 70.  
Thus, for example, each order that is entered by a  
consumer using keyboard 46, can immediately be  
20 coupled via controller 50 and modem 66 to the  
remote computer system (not shown) to begin  
processing the order. Also, to avoid loss of an  
order, each order can be stored in memory 62 and  
then, at the end of a given period, all the stored  
25 orders can be fetched from memory 62 by the remote  
computer system via controller 50 and modem 66 to  
determine if any have not been processed.  
Furthermore, as will be further described, the  
remote computer system can instruct controller 50  
30 via modem 66 to control character generator 26 to  
generate characters to display, for example,  
changed or current pricing information. Video  
display terminal 12 also has a printer 72 that can  
provide the consumer with a hard copy of any order

that is placed. Printer 72 is coupled to controller 50 over a bidirectional line 74.

In the operation of system 10, generally, the video display terminal 12 is normally in an "attract" mode, by which potential users will be attracted to the display 24. In this attract mode, microprocessor system controller 50 controls video disc player 16 to play repeatedly, for example, a one-minute video sector on disc 18 which is displayed on display 24 via video switch and character generator 26. The one-minute video sector can be any visual information that might attract the potential user. During this attract mode, no sound information is produced by circuit 32.

Then, if a potential user is attracted by the attract mode and comes into proximity with the terminal 12, sonar detector 40 will detect the potential user. Detector 40 then sends a detect signal over line 58 to controller 50 which responds by resetting video display player 16 to the beginning of the attract mode via line 52 and activating synthetic music generator and audio amplifier circuit 32. Now, an initial mode is activated in which the attract mode visual information is repeated continually on display 24 and accompanying sound data stored on corresponding tracks of video disc 18 are produced and heard via circuit 32. The sound data can, for example, be audio that informs the potential user of the ability to see and order various products via terminal 12. If the potential user is interested in "shopping" for products via terminal 12, the user is informed by display 24 to insert a

credit card in credit card reader 42.

If the credit card is inserted in reader 42, controller 50 responds to a credit card detection signal on line 60 by controlling, or  
5 activating video display player 16 to play product information stored on disc 18 at the selection of the user, as will be further described. This product information includes video information showing, for example, pictures of the products  
10 that are produced on display 24 and sound information that, for example, explains the products via circuit 32. In addition, controller 50 will control video switch and character generator 26 to generate textual data that are  
15 overlaid on each picture shown on display 24, such as price. Also, controller 50 will control circuit 32 to generate synthetic music. Details of the manner in which the user controls terminal 12 to sequence through all the product information  
20 stored on disc 18 will be discussed below in connection with the flow charts to be described.

Then, if the user selects a particular product to order, controller 50 controls video disc player 16 to play instruction data that are  
25 produced on display 24. The user then reads this instruction data and inputs, via control and address keyboard 46, order data such as the product identification number, the user's address, the address for delivery of the selected products,  
30 etc. Controller 50 then responds to this order data by transferring it to the remote central computer (not shown) via telephone modem 66 and storing it in memory 62. Controller 50 also gives the user a hard copy of the order and a receipt

via printer 72.

At the end of a given period, for example at the end of each day, the remote central computer (not shown) can fetch all the order data from all the users via modem 66, controller 50 and memory 62. Any orders that have not been processed by the remote central computer (not shown) can then be detected and processed.

Fig. 2 is an artist's conception of the video display terminal 12. Fig. 2 illustrates the TV display 24, the speakers 36 of circuit 32, the sonar detector 40, the credit card reader 42 and the control and address keyboard 46. The remaining components of video display terminal 12 are located within a housing 76.

Figs. 3A - 3E, to which reference now will be made, are flow charts used to explain in more detail the operation of video display terminal 12. Initially, terminal 12 is in the attract mode (block 78). If the sonar detector 40 is activated by a potential user being in proximity of about, for example, two feet of the terminal 12, then the attract mode is reset and audio is started (block 80). This constitutes the initial mode in which more visual and audio information are given to the user to explain the terminal 12 and provide a stronger marketing effort. If a credit card is not inserted in reader 42 (block 82) and if no user is detected by sonar detector 40 or no credit card is inserted in reader 42 after ten loops (block 84), the program returns to the attract mode (block 78). If a credit card is inserted in reader 42, but can't be read (block 86), then a message is displayed on

display 24, such as "Try Again Or Other Card". After five tries of reading a credit card, the message "Sorry" is displayed on display 24 (block 86) and the program returns to the attract mode (block 82, block 84 and block 78).

If the credit card inserted in reader 42 is read (block 82), then a visual and audio introduction to various collections stored on video disc 18 are presented (block 88), which is the start of the play mode. For example, there can be four collections of items such as flowers, luggage, fashions and consumer electronics products. Next, a visual and audio introduction to collection No. 1 is presented (block 90), followed by a video frame of user instructions of how to call up the various items in collection No. 1 plus a display of item No. 1 of collection No. 1 (block 92).

Control and access keyboard 46 has a key A (not shown) representing forward and a key B (not shown) representing back. If the user then wants to view items Nos. 2 - n of collection No. 1, each time the key A is depressed, the next item is called up and displayed on display 24 or if key B is depressed, the item previously displayed is called up (block 94). When item No. 1 is displayed, only key A is active to go forward to the next item (block 96). This process continues until the user has viewed all the items of collection No. 1.

Then, the user can depress key A one more time to call up the introduction to collection No. 2 (block 98), which is automatically followed by an instruction frame and

display of item No. 1 of collection No. 2 (block 100). Then, key A or key B can be depressed to call up individual frame displays of the items of collection No. 2 (block 102 and block 104),

5           A similar process occurs as described above to call up collection No. 3 and collection No. 4, as indicated by block 106, block 108, block 110, block 112, block 114, block 116, block 118 and block 120.

10           Then, a mosaic of some of the items of collection No. 1 can be displayed (block 122). If the user then depresses key B (block 124) the program returns to the introduction to the collection No. 1 (block 90). If key B is not  
15 depressed, a mosaic of collection No. 2 is then automatically displayed (block 126) followed by a return to the introduction to collection No. 2 (block 98) if key B is then depressed (block 128). This process continues for a mosaic No. 3 and a  
20 mosaic No. 4, as shown by block 130, block 132, block 134 and block 136. After a mosaic of collection No. 4 is displayed (block 134), an introduction to an unsolicited product presentation is displayed (block 138), which means  
25 that terminal 12 can call up on display 24 a selected number of products that might be of particular interest to the user. Block 138 is an optional step in the flow charts that could be implemented.

30           Control and address keyboard 46 has another control key C. If the user views an item or product of any collection No. 1 - No. 4 (block 92, block 100, block 108 and block 116), and the user is interested in a more detailed explanation

of that item or product, then key C is depressed .  
(block 140 or block 142 or block 144 or block  
146). As a result of depressing key C, a more  
complete video and audio presentation is made of  
5 the product (block 148), followed by a freeze  
frame detail of the product including available  
sizes and colors of the product (block 150), and  
then a freeze frame of the product including  
product price and shipping charges (block 152).  
10 If key B is depressed (block 154), the program  
returns to an introduction to collection No. 1  
(block 90), or if key B is depressed (block 156),  
the program returns to the product presentations  
(block 148) or if key B is depressed (block 158),  
15 the program returns to product details (block  
150).

After the products are displayed (block  
152), if key B is depressed (block 160), the  
program returns to the product presentations  
20 (block 148). If key A is depressed (block 160),  
the user is given an option to bypass a display of  
an order demonstration (block 162). If key B is  
depressed (block 164) the order demonstration is  
bypassed and an order form appears on display 24  
25 together with a picture of the product being  
ordered in the top right corner of display 24  
(block 166). If key A is depressed (block 164) an  
order entry demonstration is given (block 168)  
followed by a display of the order form (block  
30 166). If there is a time-out, i.e., if key A or  
key B is not depressed, (block 164), the order  
entry demonstration is given (block 168). If the  
order form is displayed (block 166), an order  
demonstration can be selected by depressing key A

(block 170), which returns the program to block .  
168.

5 When the order form is displayed (block  
166), the user then keys in the order data, being  
requested using keyboard 46 (block 172), which can  
include a gift card message and product delivery  
date (block 174). If an error is made by the user  
in keying in the order data, then the user can  
edit the data (block 176 or block 178).

10 Next, the user's credit card is inserted  
in reader 42 (block 180), and if the credit card  
number can be read the order is accepted and a  
thank you message displayed on display 24 (block  
182). If one or another credit card can't be read  
15 after five tries (block 184), a message "Sorry" is  
displayed, together with a message "Thank You For  
Window Shopping" (block 186). Then, after  
ordering or trying to order a product, key B can  
be depressed (block 188) and a return is made  
20 (block 190) to the introduction to collection No.  
1 (block 90) should the user want to order any  
other products. After a time-out (block 188), the  
order is entered and a return is made to the  
attract mode (block 78).

25 In connection with the video switch and  
character generator 26, Fig. 4A illustrates the  
NTSC standard video signal used in the broadcast  
industry for TV video displays. The video signal,  
as shown, has a horizontal blanking interval, a  
30 horizontal synchronization portion (H Sync.) and a  
display portion during which one scan line of a  
frame of video is displayed. As previously  
mentioned, the NTSC standard video signal  
precisely defines all timing relationships by



which video information and textual information are displayed.

5 The video disc 18 stores video data in accordance with the NTSC standard signal shown in Fig. 4A. One problem, though, is that due to variations in the speed of rotation of the video disc 18 or the precision by which the video data are stored on video disc 18, or other factors, the timing of the NTSC standard signal being read from the video disc 18 may vary from scan line to scan line. While in the broadcast industry, the standards are precise such that the timing must be the same from scan line to scan line, this precision is not necessarily required to display adequately overlaid text on video from scan line to scan line of display 24. Consequently, as indicated by the waveform of Fig. 4B, which is a waveform showing the timing for displaying text produced or generated by the video switch and character generator 26, a display portion always is accurately referenced with respect to the occurrence of H Sync., however that may vary due to any varying scan line-to-scan line timing provided by video disc 18. Particularly, the leading edge of the display portion shown in Fig. 4B is precisely related to the trailing edge of H Sync. interval, whenever the latter occurs.

Fig. 5 is a block diagram of the video switch and character generator 26. The NTSC standard video signal stored on video disc 18 and read by video disc player 16 is inputted over line 28 to a conventional level clamping and synchronization separator 192. Separator 192 separates the video information from the

horizontal and vertical synchronization signals (H sync. and V sync.) and provides these on a line 194, a line 196 and a line 198, respectively. A horizontal and vertical location counter circuit 200, which is described in more detail in connection with Fig. 6, responds to the H sync. and V sync. signals on line 196 and line 198, respectively, by outputting address data on a line 202. A conventional screen RAM 204, which contains codes associated with each character to be displayed, responds to the particular data on line 202 by outputting the appropriate character codes on a line 206. A conventional graphics ROM 208, which responds to the codes on line 206 and 3-bit data on line 202 identifying any one of eight lines of the particular character to display, outputs on a line 210 that one line of the character. A video summer 212 then sums the video on line 194 and the character data on line 210 and outputs this summed video onto line 30 for display on display 24.

Fig. 6 is a detailed block diagram of the location counter circuit 200. A 9-bit counter 214 is clocked at a 5MHz rate by the output of a clock generator 216 via a line 218. An H sync. detector 220 detects H sync. on line 196 and produces a load counter signal on a line 222 to preload counter 214 to a particular count with each detection of H sync. Counter 214 then counts up and when a predetermined count is reached, a pulse or logic 1 is produced on a line 226.

A counter 228 is clocked in response to each logic 1 on line 226. Counter 228 has an output on a line 230 that is connected as an input

to a flip-flop 232, whose output is a signal  $\overline{V}$  Blank. A detector 234 detects V sync. on line 198 and outputs a clear pulse on a line 236 to clear counter 228. Counter 228, together with counter 214, as shown, output onto line 202 the total of 13-bit data indicated in Fig. 5.

In the operation of location counter circuit 200, when H sync. of the waveform shown in Fig. 4A is detected, counter 214 is preloaded to a particular count. This corresponds to the trailing edge of H sync. shown in Fig. 4A. Then, counter 214 counts from the particular count to a count of 000000000. This corresponds to the start of the display portion for text as shown in Fig. 4B. Then, when counter 214 counts to the above-mentioned predetermined count, the most significant bit of the count goes to logic 1 on line 226. This, as indicated in Fig. 4B, is the end of the display portion. Thus, during this display portion of Fig. 4B, text can be displayed on display 24. Moreover, the start of the display portion, i.e., when counter 214 counts to 000000000, always tracks the trailing edge of H sync., whenever that occurs.

Counter 228 is clocked with each pulse on line 226, which occurs every horizontal scan line. After sixteen such scan lines, counter 230 outputs a pulse on line 230, resulting in flip-flop 232 outputting the signal  $\overline{V}$  Blank. At this time, the text can begin to be displayed, i.e., at sixteen lines from the top of display 24. At the end of one picture frame, V sync. is detected to clear counter 228 and the process repeats for another frame.

Thus, text produced by generator 26 can be displayed on display 24 over the video stored on disc 18. The timing of this text, as indicated by the signal waveform of Fig. 4B, is always  
5 related to the timing of the NTSC signal of Fig. 4A, however the latter may vary. Furthermore, screen RAM 204 can be written by the external system computer (not shown) via modem 66 and microprocessor system controller 50 to store  
10 updated data such as new pricing information for a particular item for display on display 24 with the particular item.

A number of alternative embodiments to those already described can be developed within  
15 the principles of the present invention. Fig. 2 illustrates one form of terminal 12; however, other versions can include a sit-down cabinet mode, a sit-down booth with one or more terminals 12, a counter-top mode, a cocktail table mode and  
20 a wall-installed mode like a walk-up automatic bank teller terminal. Alternatives to the keyboard 46 can include a touch screen mode, a track ball or cursor mode, a joystick and a light pen.

Furthermore, video disc 18 has been  
25 described as storing video and audio information about products. However, video disc 18 can also store a number of different video games that can be selected by a user of terminal 12 using keyboard 46. The user would also key in with  
30 keyboard 46 the credit card and other appropriate data for charging the user for playing the selected video game and then the disc player 16 can be activated by microprocessor system controller 50 to call up the selected video game.

Also, the audio tracks of disc 18 can be used in place of the audio to dump or write other video games on the disc 18 via the remote system computer (not shown), modem 66 and microprocessor system controller 50.

Furthermore, the audio tracks can be used to store the software of the present invention, which software can then be loaded into microprocessor system controller 50 to perform the functions previously described. Alternatively, this software can be stored in a tape cartridge, which is then inserted into the terminal 12 in the field on installation of the terminal 12, whereby the software will then be loaded into controller 50.

Also, terminal 12 is shown as having one video disc player 16 and one video disc 18 for displaying still frames of items. An alternative can include two video disc players 16 and two video discs 18 in the one terminal 12. One of the video disc players 16 and corresponding disc 18 can be operated in a constant linear velocity mode to display motion sequences on display 24. The other disc player 16 and disc 18 can be operated to display the still frames.

An advantage of using the two disc players 16, which can be of the inexpensive type having long data access times, is that the two in combination can act as one very fast access time player by interleaving the search time of one player with the playing time of the other player. A further advantage is that the playing time of the two in combination is increased. The total purchase price or cost of using the two

inexpensive (e.g. consumer-purchased) players, is considerably less than one "intelligent" industrial video disc player.

5 Naturally one skilled in the art may apply the system to a PAL or SECAM system as the synchronising principles are similar to NTSC but with slightly different frequencies.

10 Published on the same day as this application in the official file thereof are copies of an Appendix A and an Appendix B to this specification which are source code listings with comments that implement the program shown in the flow charts previously described. Also, the microprocessor system controller 50 can be, for example, a  
15 controller known as a Model 800 Atari home computer system, manufactured by Atari, Inc., Sunnyvale, California, which includes a Model 6502 microprocessor manufactured by Synertek, Inc. The attached source code listings are written in  
20 connection with such a controller.

Other aspects, objects and advantages of the invention can be obtained from a study of the drawings, the disclosure and the appended claims.

Claims

1. Apparatus for marketing items,  
comprising:

a) means for providing information about  
the items;

5 b) means for communicating the  
information to a user;

c) means for sensing predetermined  
conditions;

10 d) means for ordering selectively the  
items; and

e) data processing means for controlling  
said information providing means and said communicating means  
to communicate a portion of the information in  
response to the absence of the predetermined  
15 conditions and to communicate an additional  
portion of the information in response to one of  
the sensed predetermined conditions and to  
communicate all of the information in response to  
another of the sensed predetermined conditions and  
20 to control the ordering of the items.

2. Apparatus, according to claim 1,  
wherein said means for providing information comprises:

a) a video storage medium having video  
information; and

25 b) means for generating character data.

3. Apparatus, according to claim 2,  
wherein said means for communicating comprises a  
video display for displaying the video information  
and the character data superimposed on the video  
30 information.

4. Apparatus, according to claim 1, wherein said means for providing information comprises a storage medium having video and sound information.

5 5. Apparatus, according to claim 4, wherein said means for communicating comprises:

a) means for displaying the items in response to the video information; and

b) means for generating audio in response to the sound information.

10 6. Apparatus, according to claim 5, wherein said means for generating audio comprises a synthetic music generator.

15 7. Apparatus, according to any preceding claim wherein said means for sensing predetermined conditions comprises means for detecting the proximity of a user of the apparatus as the one sensed condition.

20 8. Apparatus, according to claim 7, wherein said means for detecting comprises a sonar detector.

9. Apparatus, according to any preceding claim wherein said means for sensing predetermined conditions comprises means for reading a user identifier as the other sensed condition.

25 10. Apparatus, according to claim 9, wherein said means for reading comprises a credit card reader.



11. Apparatus, according to any preceding claim wherein said means for ordering comprises a user input control for inputting item order data to said data processing means.

5 12. Apparatus, according to claim 11, wherein said user input control comprises a keyboard.

10 13. Apparatus, according to claim 11 or 12, wherein said means for ordering further comprises means for storing the item order data.

15 14. Apparatus, according to claim 13, wherein said means for ordering further comprises a modem, coupled to said data processing means and said storing means, for transmitting the item order data stored in said storing means.

15. Apparatus, according to any of claims 11 to 14, wherein said means for ordering further comprises means for providing to the user a hard copy of the item order data.

20 16. Apparatus, according to any preceding claim wherein said means for providing information further comprises:

- a) a video game computer system;
- b) means for storing at least one video  
25 game program; and
- c) means for dumping the video game program into said video game computer system in response to user command.

17. Apparatus, according to claim 16, wherein said means for communicating comprises a video display for displaying a video game, in accordance with the video game program.

5 18. A terminal for merchandising items, comprising:

a) means for providing information about the items, including a video disc player having a video disc which stores video and sound data;

10 b) means for communicating the information to a user, including

i) means for displaying the items in response to the video data; and

15 ii) means for generating audio about the items in response to the sound data;

c) means for sensing predetermined conditions, including

i) means for detecting the proximity of a user; and

20 ii) means for reading a user identifier;

d) means for ordering selectively the items; and

25 e) programmed data processing means for controlling said means for providing information and said means for communicating to

i) display a portion of the video data in response to the absence of the sensed predetermined conditions;

30 ii) display the portion of the video data and generate a portion of the audio in response to the detection of the proximity of the user; and

iii) display selectively all the video data and generate selectively all the audio in response to the detection of the proximity of the user and the reading of the user identifier.

5           19. A terminal, according to claim 18, wherein said means for displaying comprises a video display and said means for generating audio comprises a synthetic music generator.

10           20. A terminal, according to claim 18 or 19, wherein said means for detecting comprises a sonar detector and said means for reading comprises a card reader.

15           21. A terminal, according to claim 18, 19 or 20, wherein said means for ordering comprises a user controlled data input means for producing item order data.

22. A terminal, according to any of claims 18 to 21, wherein said means for ordering further comprises means for storing the order input data.

20           23. A terminal, according to claim 22, wherein said means for ordering further comprises a modem for transmitting the stored order information to a remote site.

25           24. A terminal, according to any of claims 18 to 23 wherein said means for providing information further comprises means for generating character data and for superimposing the character data on the displayed video data.

30           25. Apparatus for controlling the display of first and second information on a display, comprising:

a) means for generating first timing signals to control the display of the first information on the display, the first timing signals being susceptible to variations in timing;  
5 and

b) means for generating second timing signals to control the display of the second information on the display in response to the first timing signals.

10 26. Apparatus, according to claim 25, wherein said means for generating the second timing signals comprises.

a) means for generating clock signals;  
and

15 b) means for counting the clock signals, said counting means being preset to a count in response to the first timing signals and then enabling the display of the second information for a predetermined number of counts.

20 27. Apparatus, according to claim 26, wherein said counting means commences enabling the display of the second information a predetermined number of counts after the preset count.

28. A video display system, comprising:

25 a) a video display;

b) first means for storing and outputting first video information and horizontal synchronization signals, said horizontal synchronization signals being susceptible to  
30 variations in timing;

c) means for generating timing signals in response to the horizontal synchronization signals;

d) second means for storing and outputting second video information in response to the timing signals; and

5 e) means for combining said first video information and said second video information, said video display displaying said first video information and said second video information in response to the horizontal synchronization signals.

10 29. A video display system according to claim 27 wherein said first means for storing and outputting further comprises means for outputting vertical synchronization signals, said means for generating timing signals generates a vertical enabling signal in response  
15 to a predetermined number of the horizontal synchronizing signals and said video display is responsive to the vertical enabling information to display the second video information.

20 30. A video display system according to claim 29 wherein said first means for storing and outputting comprises a video storage disc.

31. A video display according to claim 29 or 30 wherein said second means for storing and outputting comprises a character generator.

25 32. A video display according to any of claims 28 to 31 wherein said means for generating timing signals comprises:

a) means for generating clock signals;  
b) means for counting the clock signals,  
30 said counting means being preset to a count in response to each of the horizontal synchronization signals and then enabling the display of the second video information for a predetermined number of counts.

33. A video display system according to claim 32 wherein said counting means commences enabling the display of the second video information a predetermined number of counts after  
5 the preset count.

34. A video display system according to claim 32 or 33 wherein said counting means generates a second clock signal at the predetermined number of counts and said means for generating further  
10 comprises second means for counting each second clock signal, said second counting means being cleared in response to each of the vertical synchronization signals.

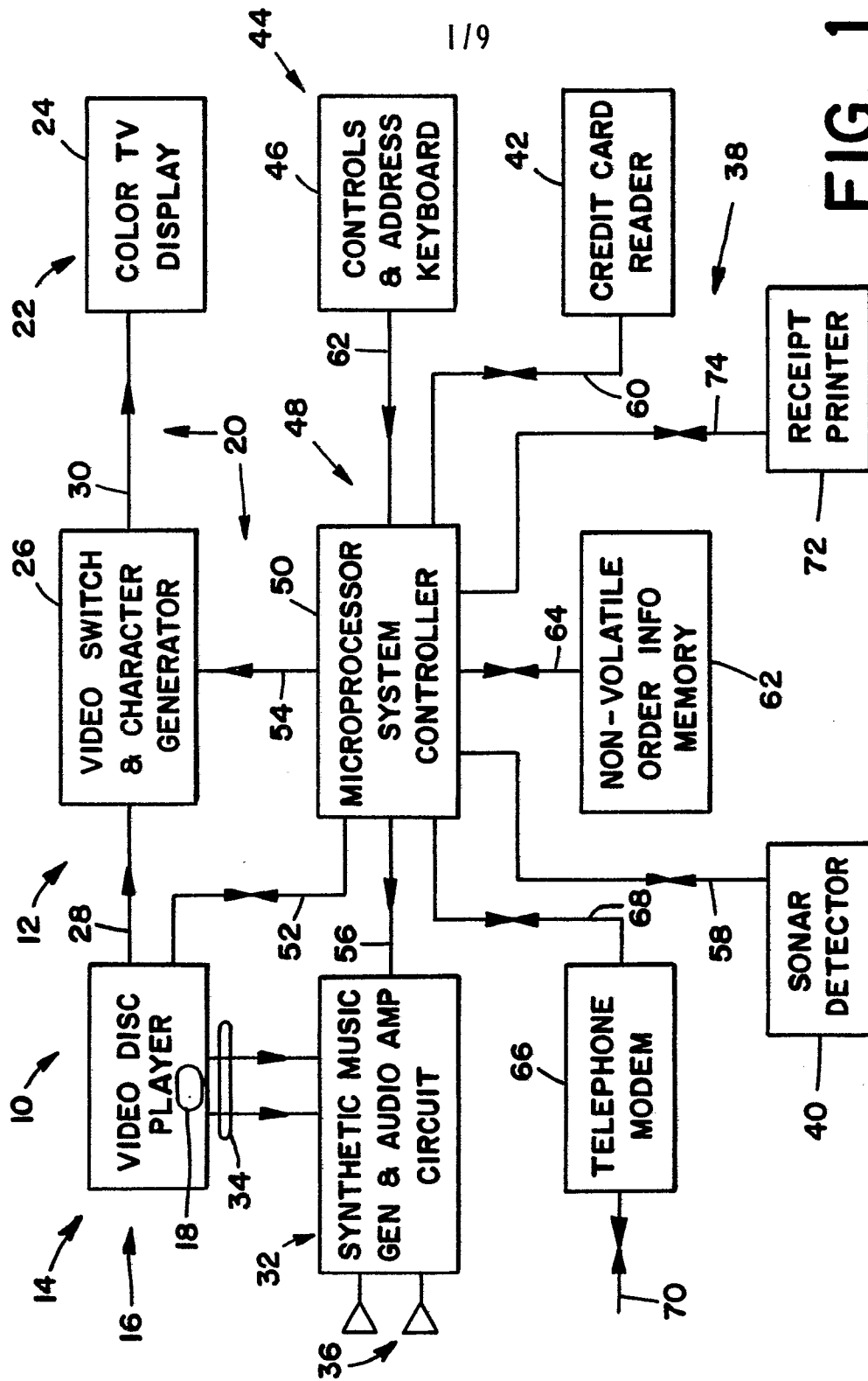
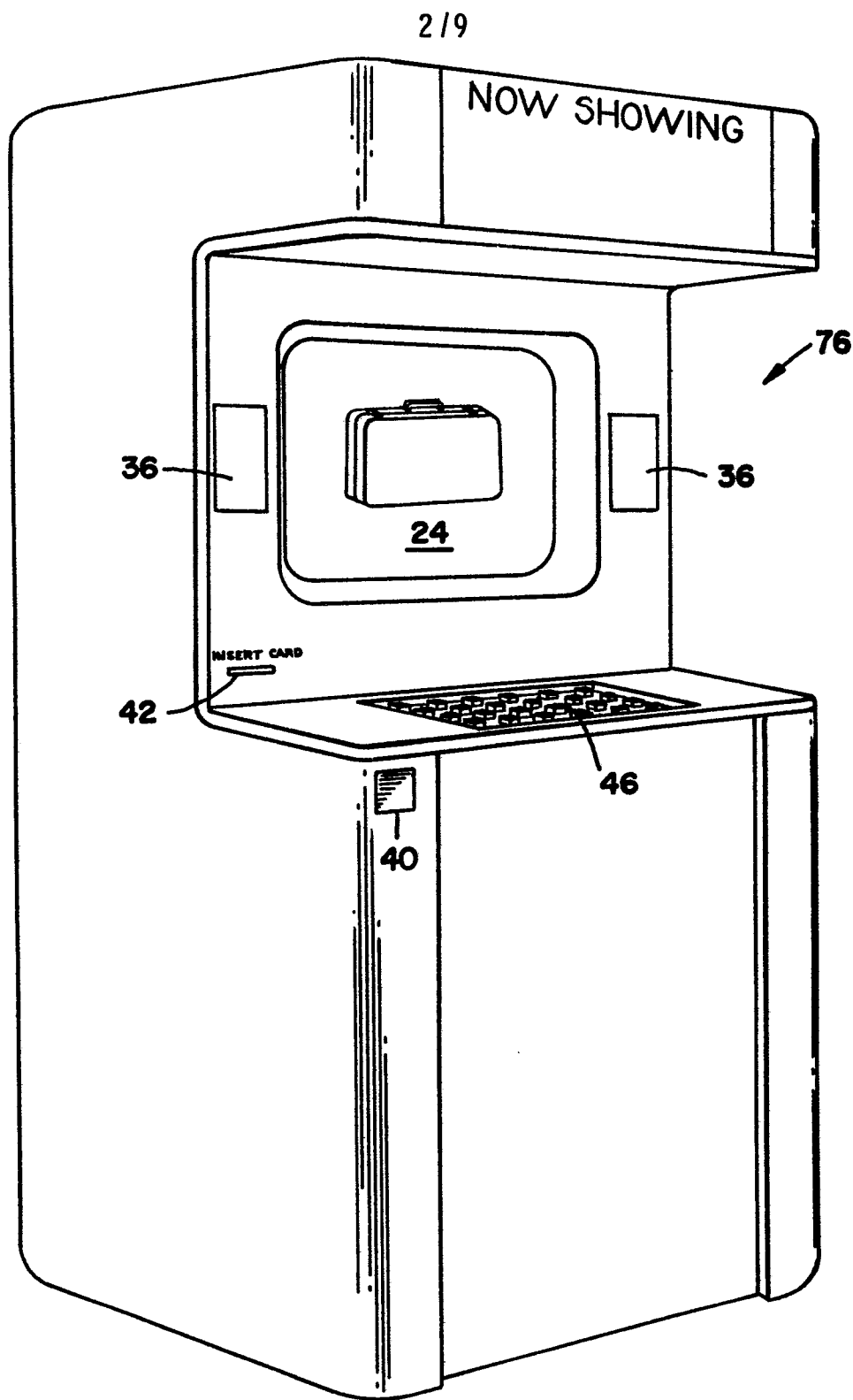

FIG-1



FIG\_2



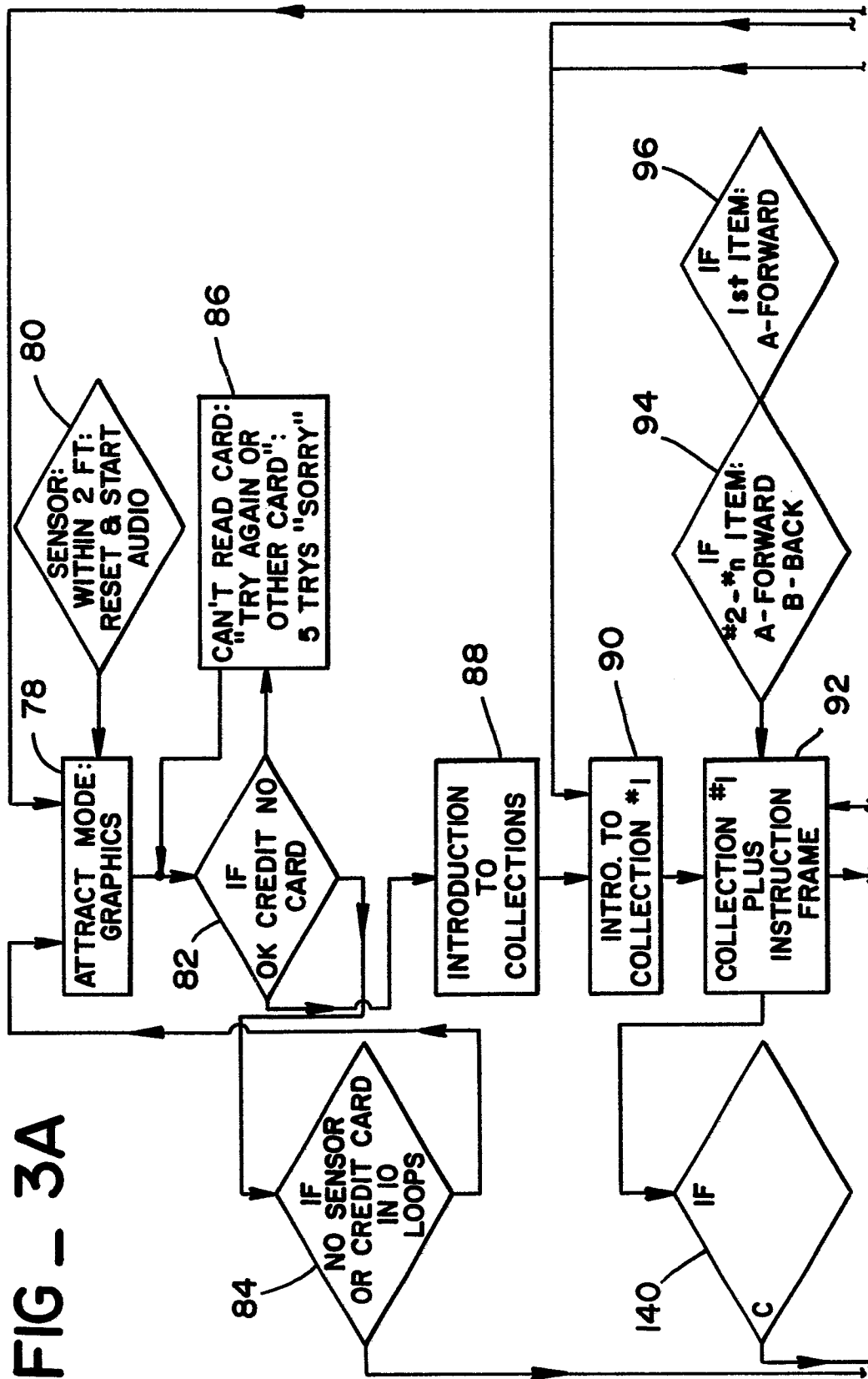

FIG - 3A

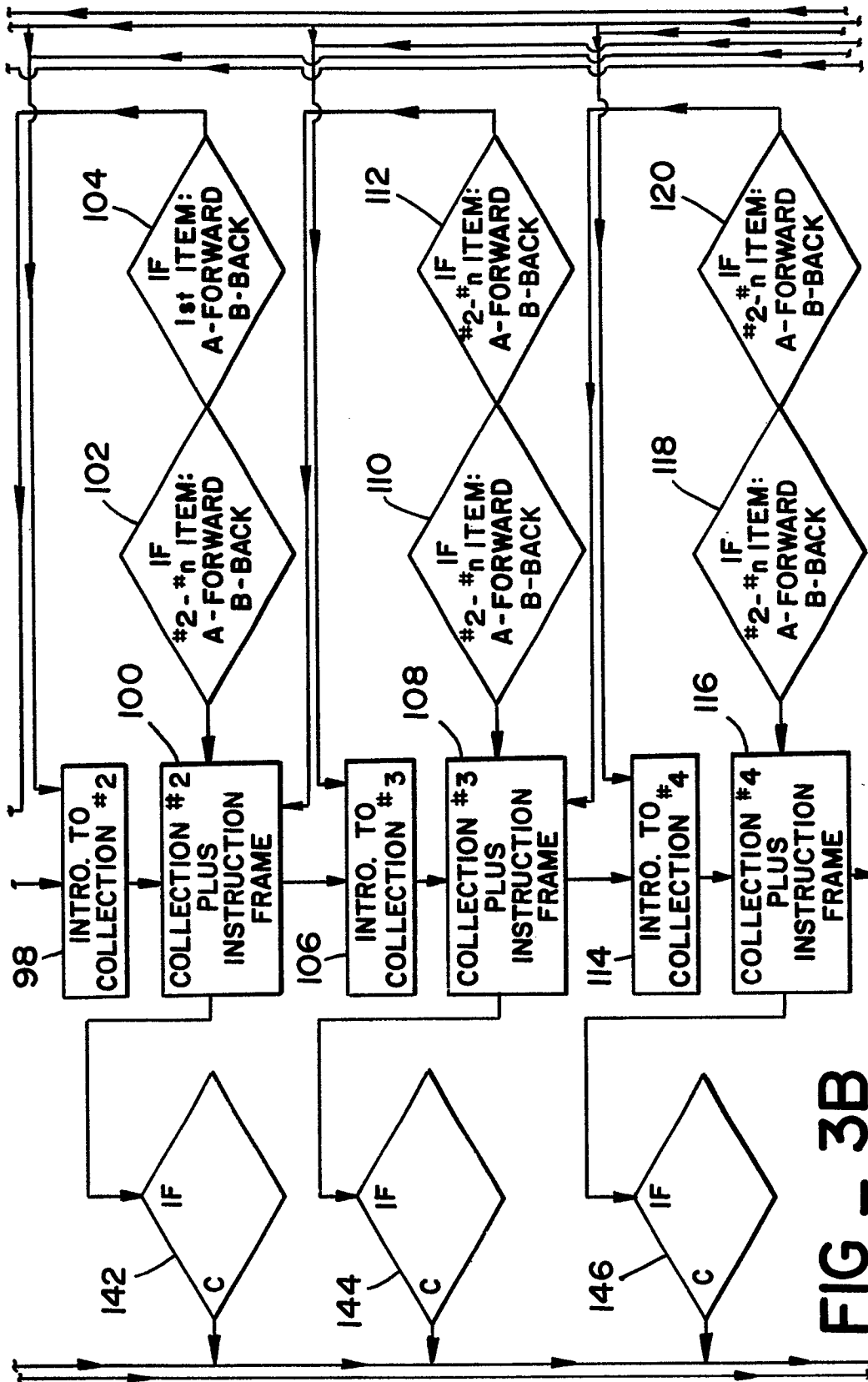

FIG - 3B

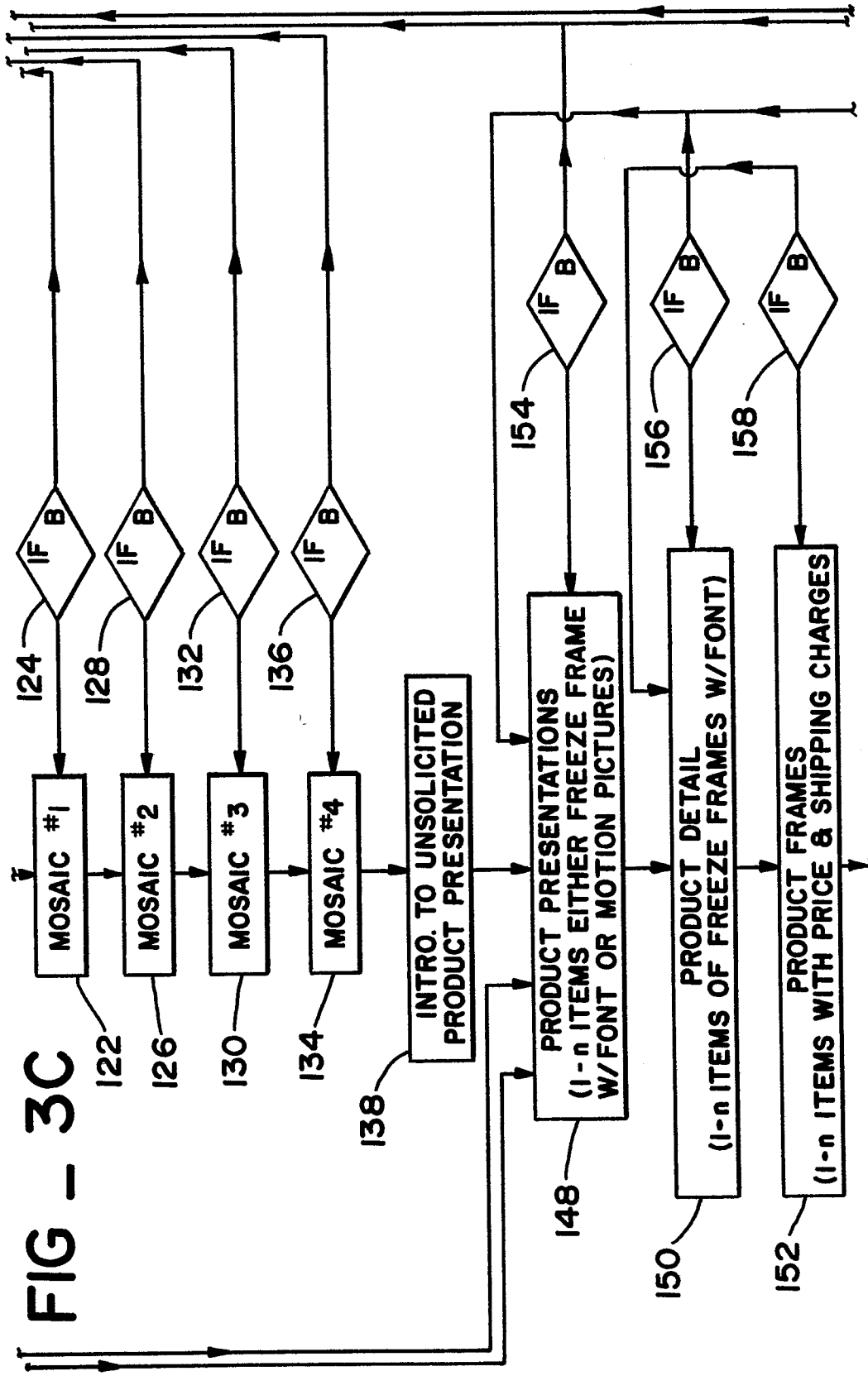

FIG - 3C

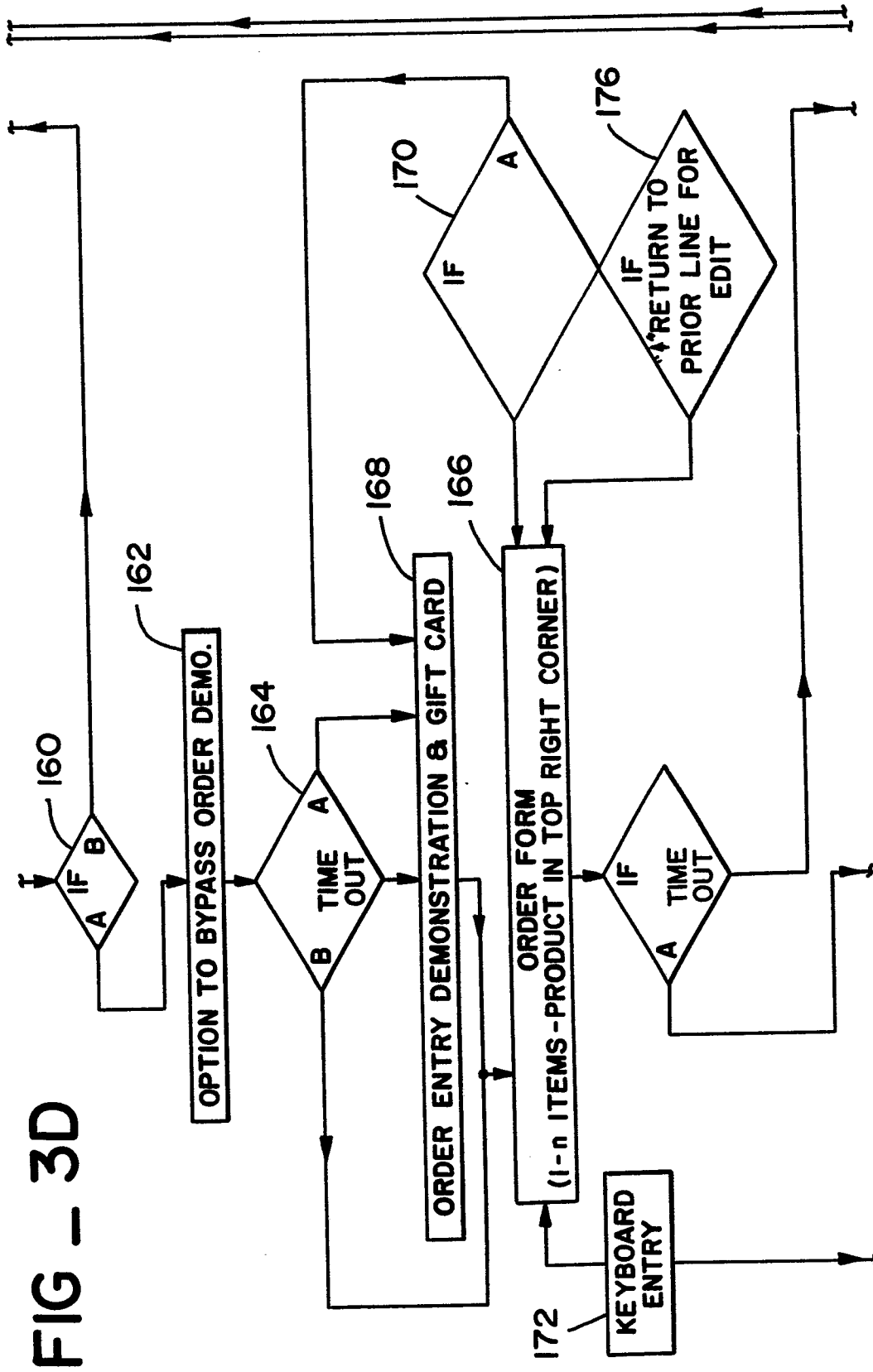

FIG - 3D

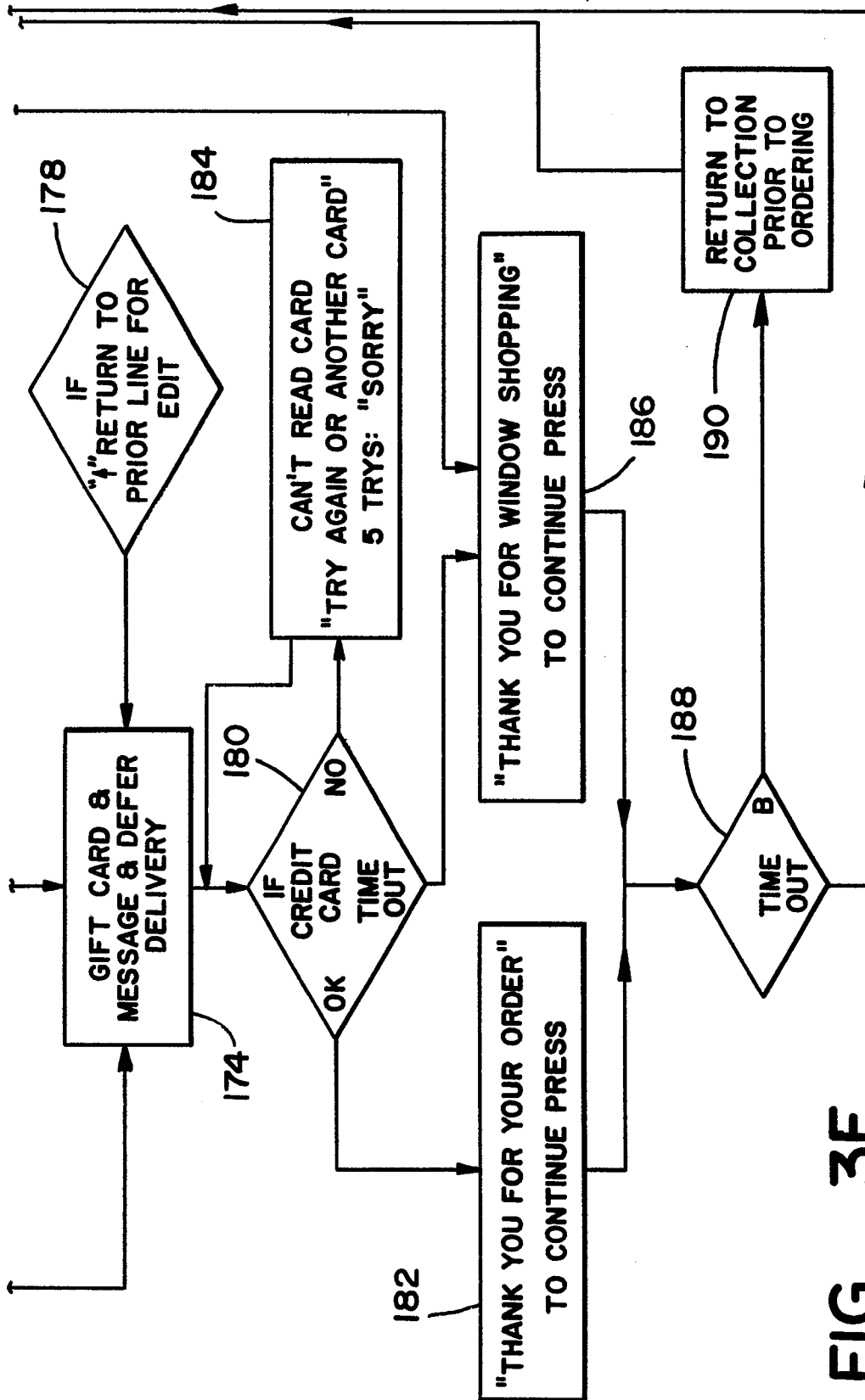
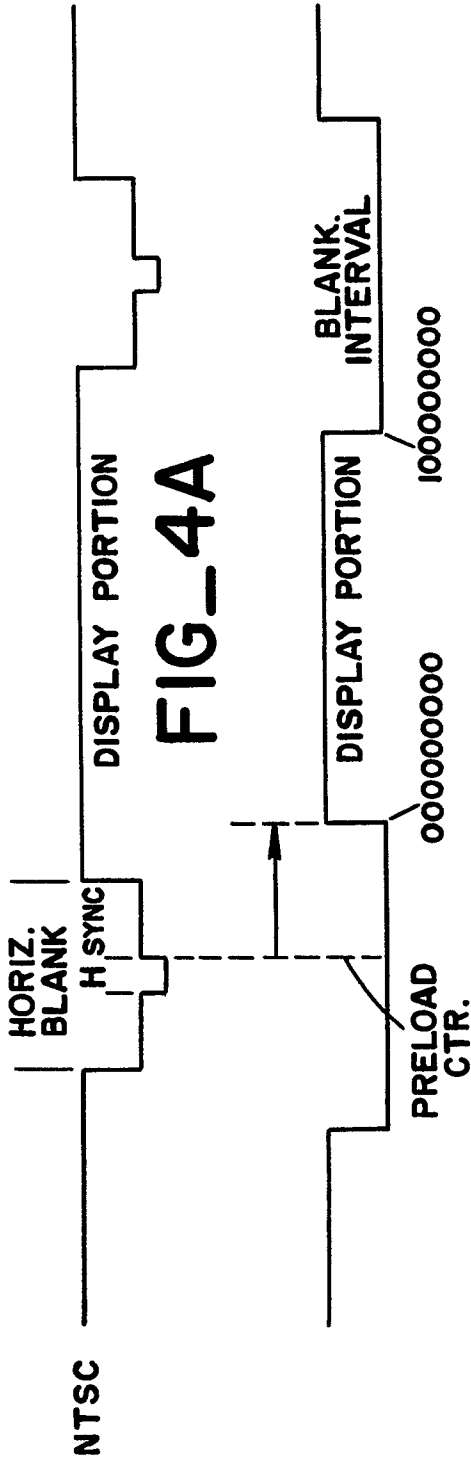
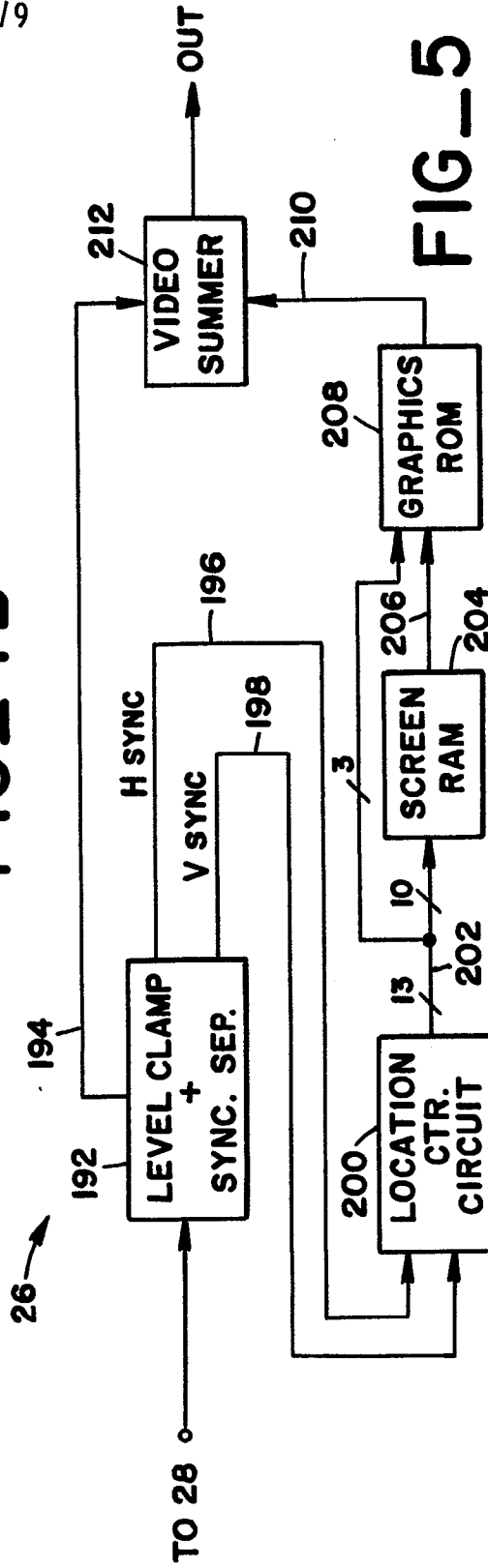

FIG - 3E



8/9

FIG\_4B



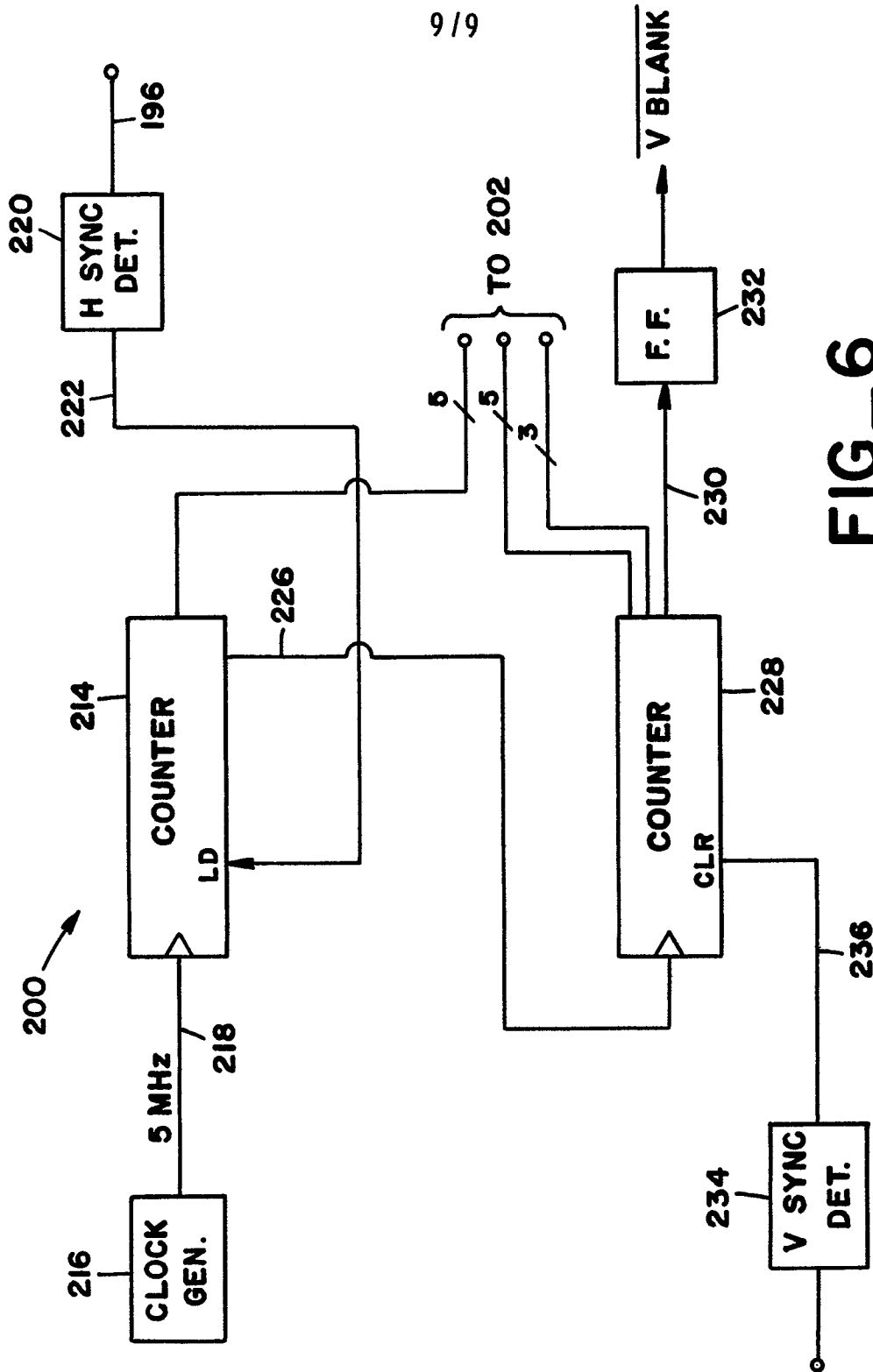

FIG-6



European Patent  
Office

**EUROPEAN SEARCH REPORT**

0109189

Application number

EP 83 30 6220

DOCUMENTS CONSIDERED TO BE RELEVANT			
Category	Citation of document with indication, where appropriate, of relevant passages	Relevant to claim	CLASSIFICATION OF THE APPLICATION (Int. Cl. <sup>3</sup> )
A	US-A-3 861 792 (DONATI) * Abstract; column 2, lines 10-56; column 4, line 65 - column 5, line 14 *	1, 2, 4, 7	G 06 F 15/24 G 09 F 27/00
A	--- US-A-3 818 454 (YACCINO) * Column 1, line 58 - column 2, line 34 *	1, 9, 10	
A	--- US-A-4 071 697 (BUSHNELL) * Column 1, line 59 - column 2, line 8 *	1	
A	--- US-A-3 906 457 (MATTEDI)		
A	--- FR-A-2 311 369 (LEPINE) -----		TECHNICAL FIELDS SEARCHED (Int. Cl. <sup>2</sup> )  G 06 F 15/20 G 09 F 27/00
The present search report has been drawn up for all claims			
Place of search THE HAGUE		Date of completion of the search 20-01-1984	Examiner BARRACO G.S.
<p><b>CATEGORY OF CITED DOCUMENTS</b></p> <p>X : particularly relevant if taken alone  Y : particularly relevant if combined with another document of the same category  A : technological background  O : non-written disclosure  P : intermediate document</p> <p>T : theory or principle underlying the invention  E : earlier patent document, but published on, or after the filing date  D : document cited in the application  L : document cited for other reasons</p> <p>&amp; : member of the same patent family, corresponding document</p>			