

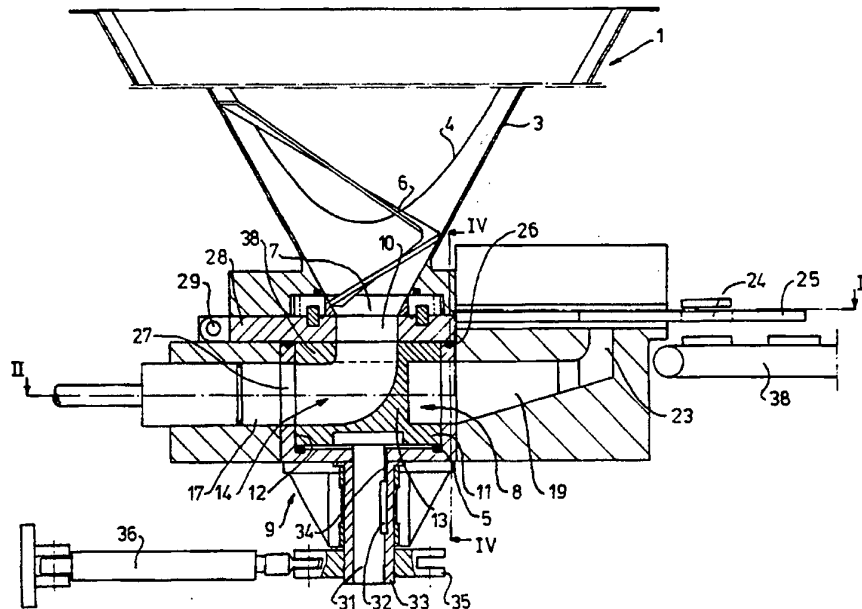

INTERNATIONAL APPLICATION PUBLISHED UNDER THE PATENT COOPERATION TREATY (PCT)

(51) International Patent Classification ⁶ : A22C 7/00	A1	(11) International Publication Number: WO 95/02332 (43) International Publication Date: 26 January 1995 (26.01.95)
<p>(21) International Application Number: PCT/NL94/00165</p> <p>(22) International Filing Date: 13 July 1994 (13.07.94)</p> <p>(30) Priority Data: 9301248 15 July 1993 (15.07.93) NL</p> <p>(71) Applicant (for all designated States except US): KOP-PENS MACHINEFABRIEK B.V. [NL/NL]; P.O. Box 1, Beekakker 11, NL-5760 AA Bakel (NL).</p> <p>(72) Inventor; and (75) Inventor/Applicant (for US only): LYGUM, Poul [DK/NL]; Helmondsestraat 18, NL-5761 CS Bakel (NL).</p> <p>(74) Agent: DE BRUIJN, Leendert, C.; Nederlandsch Octrooibureau, Scheveningseweg 82, P.O. Box 29720, NL-2502 LS The Hague (NL).</p>	<p>(81) Designated States: CA, JP, US, European patent (AT, BE, CH, DE, DK, ES, FR, GB, GR, IE, IT, LU, MC, NL, PT, SE).</p> <p>Published <i>With international search report.</i> <i>Before the expiration of the time limit for amending the claims and to be republished in the event of the receipt of amendments.</i></p>	

(54) Title: SHAPING MACHINE



(57) Abstract

A shaping machine for dividing a deformable mass, such as a meat product, into separately shaped portions comprises a stock container (1), at least two piston-cylinder units (17, 20, 18, 21) for alternately feeding in the mass from the stock container to a shaping plate (25) provided with shaped recesses (24), and also means for removing the shaped portions from the shaping plate. Valve means (8) for connecting the cylinders (17, 18) alternately to the stock container are also provided. The cylinders are accommodated next to each other in a housing which has a chamber (19) connecting at one side to the shaping plate and at the other side to the cylinders, while the valve means also operate the connection between chamber and cylinders.

FOR THE PURPOSES OF INFORMATION ONLY

Codes used to identify States party to the PCT on the front pages of pamphlets publishing international applications under the PCT.

AT	Austria	GB	United Kingdom	MR	Mauritania
AU	Australia	GE	Georgia	MW	Malawi
BB	Barbados	GN	Guinea	NE	Niger
BE	Belgium	GR	Greece	NL	Netherlands
BF	Burkina Faso	HU	Hungary	NO	Norway
BG	Bulgaria	IE	Ireland	NZ	New Zealand
BJ	Benin	IT	Italy	PL	Poland
BR	Brazil	JP	Japan	PT	Portugal
BY	Belarus	KE	Kenya	RO	Romania
CA	Canada	KG	Kyrgystan	RU	Russian Federation
CF	Central African Republic	KP	Democratic People's Republic of Korea	SD	Sudan
CG	Congo	KR	Republic of Korea	SE	Sweden
CH	Switzerland	KZ	Kazakhstan	SI	Slovenia
CI	Côte d'Ivoire	LI	Liechtenstein	SK	Slovakia
CM	Cameroon	LK	Sri Lanka	SN	Senegal
CN	China	LU	Luxembourg	TD	Chad
CS	Czechoslovakia	LV	Latvia	TG	Togo
CZ	Czech Republic	MC	Monaco	TJ	Tajikistan
DE	Germany	MD	Republic of Moldova	TT	Trinidad and Tobago
DK	Denmark	MG	Madagascar	UA	Ukraine
ES	Spain	ML	Mali	US	United States of America
FI	Finland	MN	Mongolia	UZ	Uzbekistan
FR	France			VN	Viet Nam
GA	Gabon				

Shaping machine

The invention relates to a shaping machine for dividing a deformable mass, such as a meat product, into separately shaped portions, comprising a stock container, at least two piston-cylinder units for alternately feeding in the mass from the stock container to a shaping
5 plate provided with shaped recesses, and also means for removing the shaped portions from the shaping plate.

Such a shaping machine is known from US-A-4372008. In this case a meat mass is kept ready in a container, and is conveyed in the direction of a number of vertically disposed screw conveyors by means of
10 a conveyor belt on the bottom of the container. These screw conveyors force the meat mass downwards to the entrance to the cylinders. Finally, the meat mass is pushed up into the cylinders by appropriate pistons and extruded in a shaping plate.

In order to ensure that the meat product ultimately obtained
15 has an acceptable texture, it is desirable to handle the meat mass carefully. Too rough handling leads to too great disintegration, which adversely affects the quality of the end product. In this respect the known shaping machine is not very satisfactory, owing to the conveyance movement produced by conveyor belt and conveyor screws. The meat mass is
20 often compressed too much in the vicinity of the conveyor screws, while parts of said mass also carry out a circular movement.

The object of the invention is therefore to provide a shaping machine of the above-described type which does not have these disadvantages. This is achieved through valve means being provided for
25 connecting the cylinders alternately to the stock container. The meat mass can be fed into the appropriate cylinder by way of the valve means, which ensures a more uniform treatment. The result of this is that the texture of the meat mass remains better preserved. The two cylinders are filled alternately, and they also convey the meat mass alternately to the
30 shaping plate. Despite the intervals in the feed per cylinder, a sufficiently constant feed for the entire shaping machine can still be obtained in this way.

The cylinders are accommodated next to each other in a housing which has a chamber which connects to the shaping plate at one side and
35 to the cylinders at the other side, while the valve means also operate the connection between chambers and cylinders. The valve means fulfil a dual function, namely connecting the cylinders alternately to the stock

container or to the shaping plate. For this purpose, the valve means can be moved between two positions, in each of which the connection between one of the cylinders and the chamber is shut off and the connection between that cylinder and the stock container is opened each time.

5 According to a preferred embodiment, a swivellable valve element is provided in the chamber, which valve element has a passage whose one end is permanently connected to the stock container by way of an opening in the top wall of the chamber, and whose other end in both positions of the valve element is connected to the appropriate cylinder
10 in each case. The passage provides a good uniform guidance of the meat mass to the appropriate cylinder.

The chamber can be designed with a rectangular cross-section, in that case the valve element having a bottom and top base plate with circular periphery which interacts in a sealing manner with the bottom
15 chamber wall. The valve element also has a top base plate with circular periphery which interacts in a sealing manner with the top chamber wall.

In order to improve the sealing action of the valve element, each base plate is accommodated in a correspondingly shaped recess in the appropriate wall of the chamber.

20 The swivellable valve element can be designed in various ways. According to a preferred possibility, provision is made for a channel which is bent through 90° and one end of which is concentric in relation to each base plate, while the other end can be connected to one of the cylinders in each case.

25 A special embodiment can have two pairs of piston-cylinder units and also a valve means belonging to each pair.

Moreover, each pair of piston-cylinder units can interact with its own essentially conical stock container, which stock containers intersect each other in a common vertical plane, thus forming a common
30 recess in their facing wall parts.

The invention will be explained in greater detail below with reference to the examples of embodiments shown in the figures.

Figure 1 shows a side view, partially in section, along I-I in Figure 2, of a first embodiment of the shaping machine.

35 Figure 2 shows a section along II-II of the shaping machine shown in Figure 1.

Figure 3 shows a top view of Figure 1.

Figure 4 shows an end view.

Figure 5 shows a side view corresponding to Figure 1 of a

second embodiment of the shaping machine.

Figure 6 shows a section along IV-IV.

The shaping machine shown in Figures 1 - 4 has a stock container 1, consisting of two partially conical containers 2, 3 which
5 adjoin each other with their common intersecting line 4. A screw element 6 is disposed in each container 2, 3. The rotary movement of these screw elements 6 is synchronized in such a way that they can move freely past each other in the region where the containers 2, 3 intersect each other.

At their bottom side, both containers have a hole 7, to which
10 the meat mass placed in the containers is forced in a uniform manner by the screw elements 6.

The containers 2, 3 connect with their holes 7 to respective valve elements 8, which are situated in housing 9. Said housing has a rectangular cross-section, as can be seen in Figure 4. The valve elements
15 are accessible by way of holes 10, corresponding to the holes 7, in the top of plate 28.

Each valve element 8 has a circular bottom base plate 11 and top base plate 38. These plates 11, 38 are accommodated in correspondingly shaped recesses in bottom wall and top wall respectively
20 of housing 27, and are sealed with sealing rings 5. The channel 14 extends between said plates 11, 38. Said channel 14 has a top end which opens out concentrically relative to the top base plate 38 and hole 7 of the appropriate container. The passage channel also has a part bent through 90°. This bent part can connect to one of the cylinders 17, 18.

As can be seen in Figure 2, each valve element 8 is
25 accommodated in the housing 9 in each case between two cylinders 17, 18, on the one hand, and chamber 19, on the other hand. In the position shown, each valve element 8 shuts off cylinder 18 relative to chamber 19 and allows cylinder 17 free access to said chamber 19.

At the same time, in the position shown, passage channel 14
30 forms a connection between container 2, 3 and cylinder 18, while the connection between container 2, 3 and cylinder 17 is broken.

As already mentioned, pistons 20, 21 are provided in the cylinders 17, 18 respectively. These pistons can each be driven by their
35 own drive. In the position shown, cylinders 17 are at the beginning of their suction stroke, and cylinders 18 are at the beginning of their compression stroke. During the suction stroke the cylinders 18 fill up, while the pistons 20 empty the cylinders 17, and their meat mass goes into the chamber 19. The meat mass is then forced from the bottom through

the outlet 23 into the recesses 24 in shaping plate 25. Said shaping plate is moved to and fro in a cycle, by means which are not shown, between the filling position, in which the recesses lie opposite outlet 23, and the ejection position, in which the recesses lie above the conveyor belt 38. The shaped portions are removed from the recesses 24 by means of an ejection device (not shown) and discharged on conveyor belt 38.

In order to prevent air from being sucked in during the piston stroke, sealing rings 26 are fitted, in addition to sealing rings 5. These sealing rings 26 are accommodated in a housing which is indicated in its entirety by 27, and which fits in a sealing manner into the chamber. Resting on the top of each housing is a plate 28, on which a container 2, 3 is disposed in each case. These plates 28 can be swung up about hinge 29, for the purpose of cleaning the shaping machine.

Moreover, when plate 28 is folded up the entire valve means 8 can be removed. For this purpose, the valve means is slidable, with drive shaft 31 on which key 32 is disposed, in sleeve 33 with keyway 34.

Lever 35 is fixed to sleeve 33, which lever can in turn be operated by the hydraulic piston-cylinder unit 36. The levers 35 of the two valve means are connected by way of coupling rod 37, in such a way that they are always in the same position.

In the variant shown in Figures 5 and 6 the meat mass is forced from the top into the recesses 24 in the shaping plate. This means that the channel 23 can be short, which has a beneficial effect on the quality of the shaped mass. The levers 35 are now fitted on the top side of each valve means 8.

Claims

1. Shaping machine for dividing a deformable mass, such as a meat product, into separately shaped portions, comprising a stock container, at least two piston-cylinder units for alternately feeding in the mass
5 from the stock container to a shaping plate provided with shaped recesses, and also means for removing the shaped portions from the shaping plate, characterized in that valve means are provided for connecting the cylinders alternately to the stock container.
2. Shaping machine according to Claim 1, in which the cylinders
10 are accommodated next to each other in a housing which has a chamber connecting at one side to the shaping plate and at the other side to the cylinders, while the valve means also operate the connection between chamber and cylinders.
3. Shaping machine according to Claim 2, in which the valve means
15 can be moved between two positions, in each of which the connection between one of the cylinders and the chamber is shut off and the connection between that cylinder and the stock container is opened each time.
4. Shaping machine according to Claim 3, in which a swivellable
20 valve element is provided in the chamber, which valve element has a passage whose one end is permanently connected to the stock container by way of an opening in the top wall of the chamber, and whose other end in both positions of the valve element is connected to the appropriate cylinder in each case.
- 25 5. Shaping machine according to Claim 4, in which the chamber has a rectangular cross-section, and the valve element has a bottom base plate with circular periphery which interacts in a sealing manner with the bottom chamber wall.
6. Shaping machine according to Claim 5, in which the valve
30 element has a top base plate with circular periphery which interacts in a sealing manner with the top chamber wall.
7. Shaping machine according to Claim 5 or 6, in which each base plate is accommodated in a correspondingly shaped recess in the appropriate wall of the chamber.
- 35 8. Shaping machine according to Claim 5, 6 or 7, in which provision is made for a channel which is bent through 90° and one end of which is concentric in relation to each base plate, while the other end can also be connected to one of the cylinders.

9. Shaping machine according to one of the preceding claims, in which the chamber connects to the bottom side of the shaping plate.
10. Shaping machine according to one of the preceding Claims 1 - 8, in which the chamber connects to the top side of the shaping plate.
- 5 11. Shaping machine according to one of the preceding claims, in which two pairs of piston-cylinder units and a valve means belonging to each pair are provided.
12. Shaping machine according to Claim 11, in which each pair of piston-cylinder units interacts with its own essentially conical stock
10 container, which stock containers intersect each other in a common vertical plane, thus forming a common recess in their facing wall parts.

fig-1

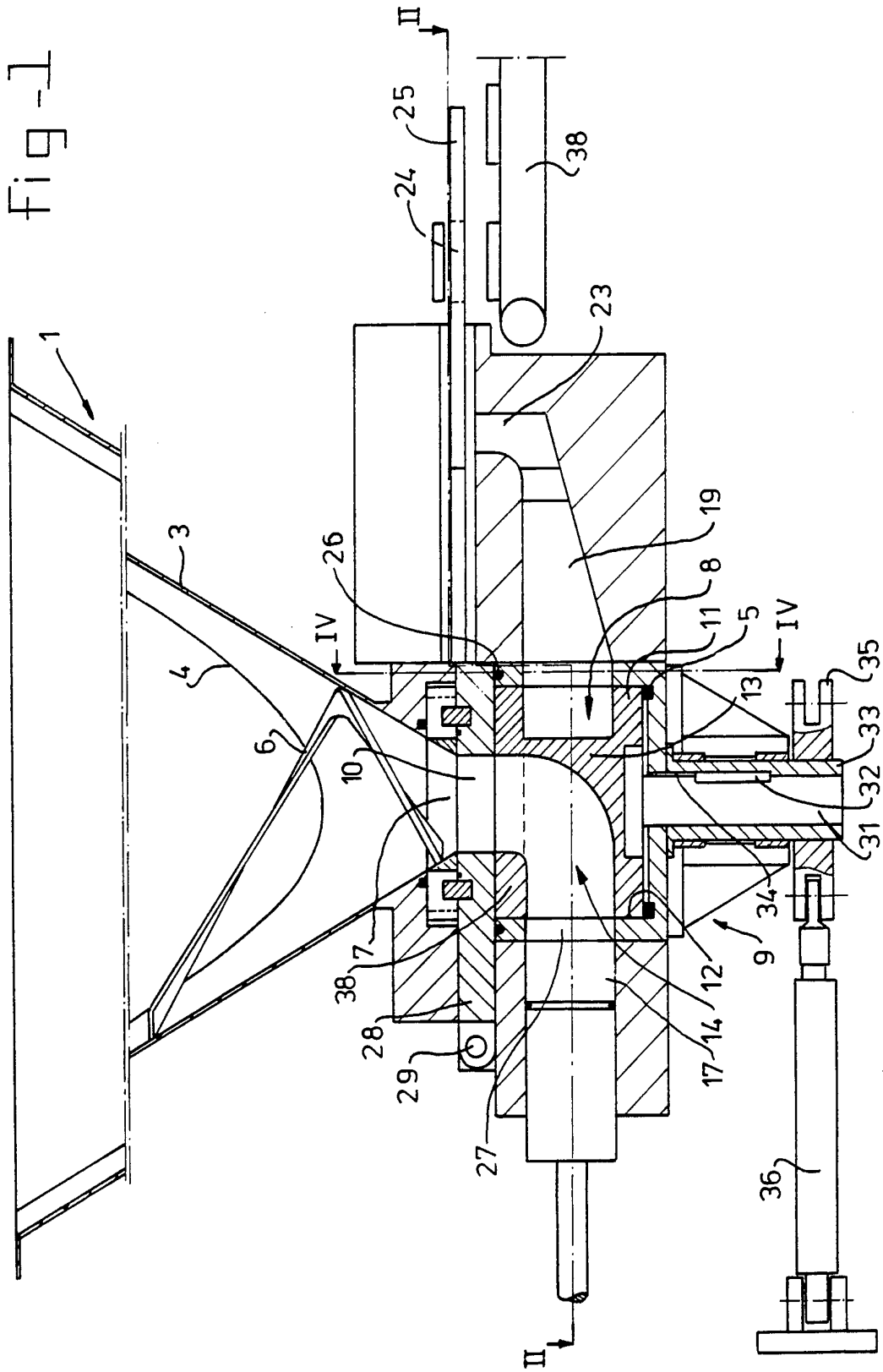

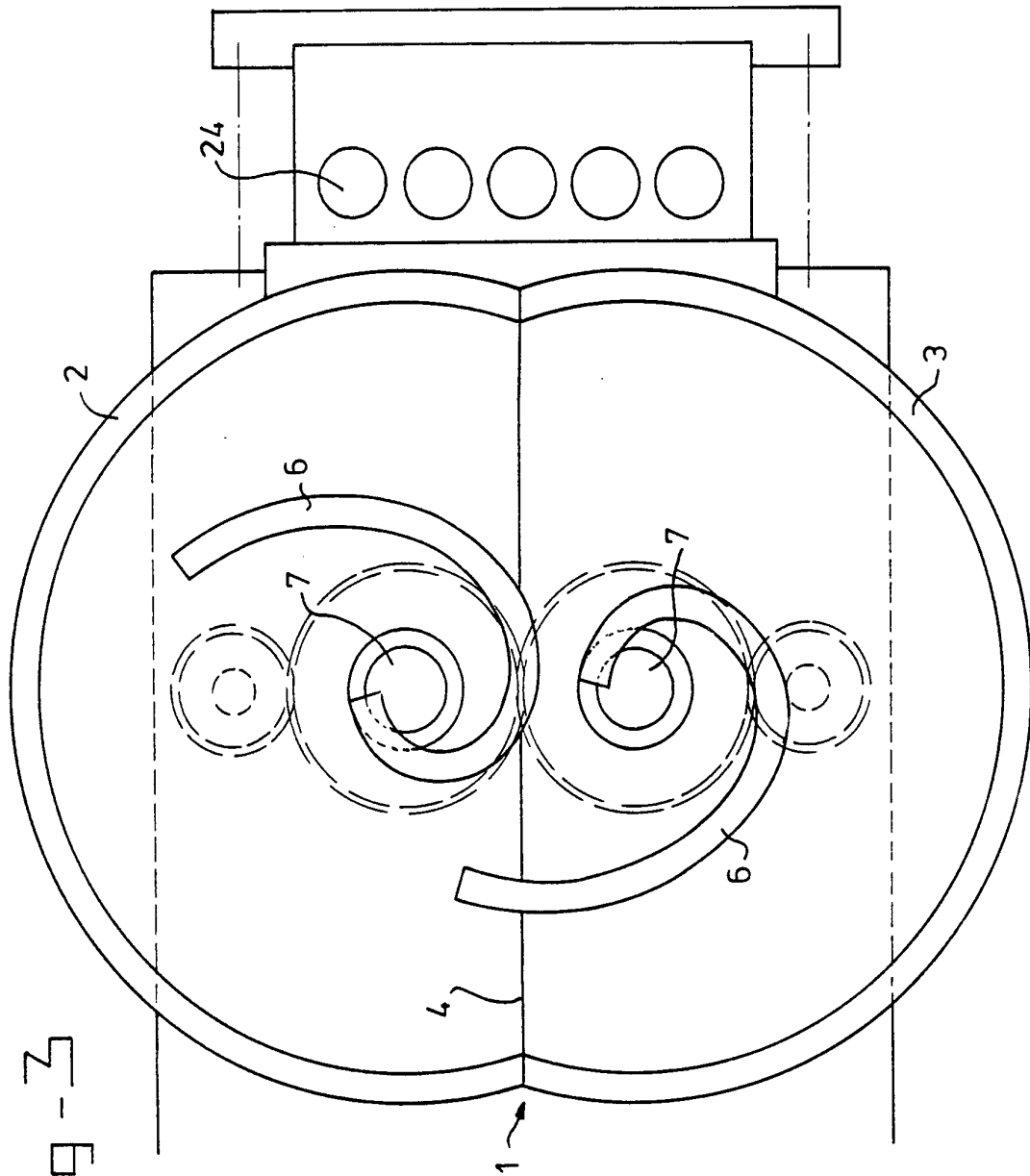

fig-3

fig-4

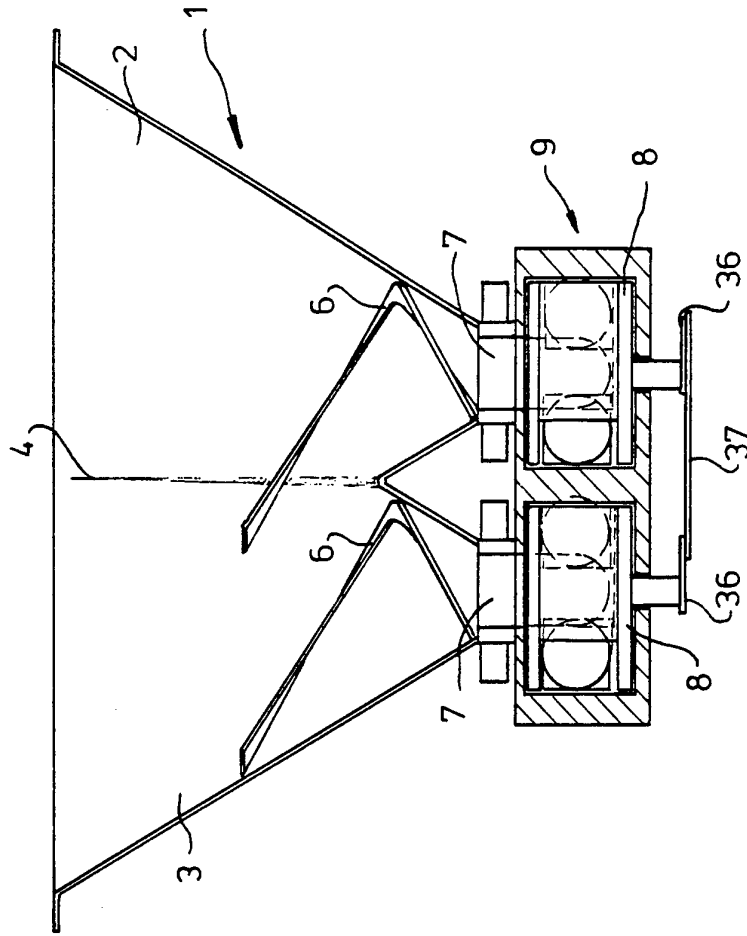
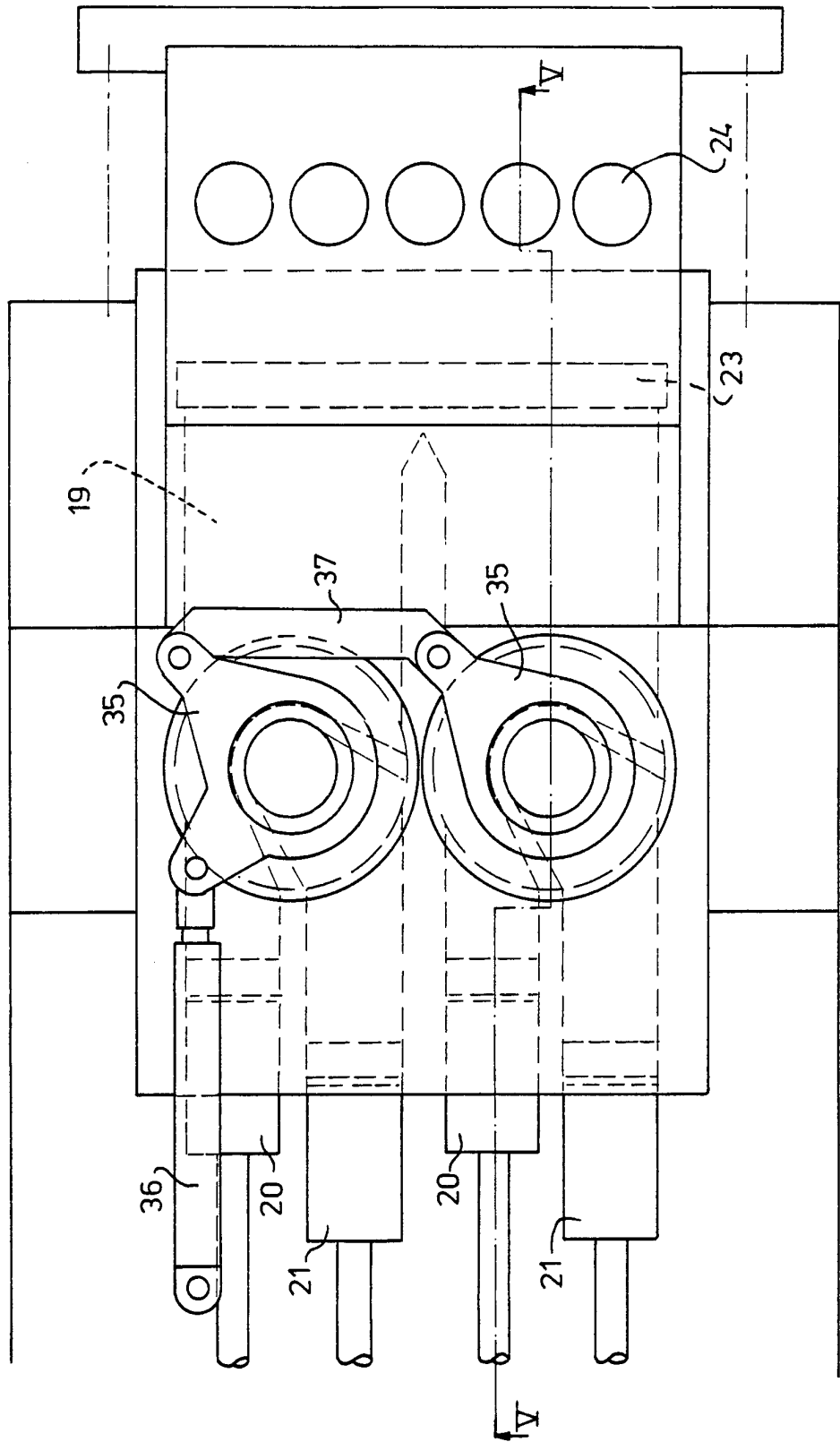

fig-6



INTERNATIONAL SEARCH REPORT

International Application No

PCT/NL 94/00165

A. CLASSIFICATION OF SUBJECT MATTER

IPC 6 A22C7/00

According to International Patent Classification (IPC) or to both national classification and IPC

B. FIELDS SEARCHED

Minimum documentation searched (classification system followed by classification symbols)

IPC 6 A22C

Documentation searched other than minimum documentation to the extent that such documents are included in the fields searched

Electronic data base consulted during the international search (name of data base and, where practical, search terms used)

C. DOCUMENTS CONSIDERED TO BE RELEVANT

Category °	Citation of document, with indication, where appropriate, of the relevant passages	Relevant to claim No.
A	US,A,5 149 298 (LINDEE) 22 September 1992 see column 3, line 60 - column 5, line 60 ---	1-7,9
A	NL,A,7 300 937 (FORMAX) 26 July 1973 see page 5, line 29 - page 12, line 23 see page 24, line 23 - line 25 ---	1-4,9, 11,12
A	GB,A,1 502 026 (DCA FOOD INDUSTRIES) 22 February 1978 see page 3, line 108 - page 5, line 38 ---	1-3,8,10
A	US,A,4 801 097 (FITCH) 31 January 1989 ---	
A	FR,A,2 156 248 (HOBART MANUFACTURING COMPANY) 25 May 1973 ---	
A	US,A,3 964 127 (HOLLY) 22 June 1976 ---	
	-/--	

 Further documents are listed in the continuation of box C. Patent family members are listed in annex.

° Special categories of cited documents :

"A" document defining the general state of the art which is not considered to be of particular relevance

"E" earlier document but published on or after the international filing date

"L" document which may throw doubts on priority claim(s) or which is cited to establish the publication date of another citation or other special reason (as specified)

"O" document referring to an oral disclosure, use, exhibition or other means

"P" document published prior to the international filing date but later than the priority date claimed

"T" later document published after the international filing date or priority date and not in conflict with the application but cited to understand the principle or theory underlying the invention

"X" document of particular relevance; the claimed invention cannot be considered novel or cannot be considered to involve an inventive step when the document is taken alone

"Y" document of particular relevance; the claimed invention cannot be considered to involve an inventive step when the document is combined with one or more other such documents, such combination being obvious to a person skilled in the art.

"&" document member of the same patent family

Date of the actual completion of the international search

3 November 1994

Date of mailing of the international search report

16. 11. 94

Name and mailing address of the ISA

European Patent Office, P.B. 5818 Patentlaan 2
NL - 2280 HV Rijswijk
Tel. (+ 31-70) 340-2040, Tx. 31 651 epo nl,
Fax: (+ 31-70) 340-3016

Authorized officer

De Lameillieure, D

INTERNATIONAL SEARCH REPORT

Internal Application No
PCT/NL 94/00165

C.(Continuation) DOCUMENTS CONSIDERED TO BE RELEVANT

Category *	Citation of document, with indication, where appropriate, of the relevant passages	Relevant to claim No.
A	EP,A,0 447 003 (STORK TITAN) 18 September 1991	
A	--- US,A,3 121 449 (MARCHADOUR) 18 February 1964	
A	--- EP,A,0 218 790 (MARLEN RESEARCH CORPORATION) 22 April 1987 -----	

INTERNATIONAL SEARCH REPORT

information on patent family members

International Application No

PCT/NL 94/00165

Patent document cited in search report	Publication date	Patent family member(s)	Publication date
US-A-5149298	22-09-92	NONE	
NL-A-7300937	26-07-73	US-A- 3887964	10-06-75
		AT-B- 335392	10-03-77
		AU-B- 447273	11-04-74
		AU-A- 5053972	11-04-74
		CA-A- 991475	22-06-76
		CH-A- 564321	31-07-75
		DE-A, C 2303436	16-08-73
		FR-A, B 2173966	12-10-73
		GB-A- 1423701	04-02-76
		SE-B- 411508	14-01-80
		US-E- RE30096	18-09-79
GB-A-1502026	22-02-78	NONE	
US-A-4801097	31-01-89	NONE	
FR-A-2156248	25-05-73	AU-B- 464967	11-09-75
		AU-A- 4757572	23-05-74
		DE-A- 2249575	19-04-73
		GB-A- 1404352	28-08-75
		US-A- 3731345	08-05-73
US-A-3964127	22-06-76	NONE	
EP-A-0447003	18-09-91	NL-A- 9000566	01-10-91
		US-A- 5182120	26-01-93
US-A-3121449		NONE	
EP-A-0218790	22-04-87	US-A- 4700899	20-10-87
		AU-B- 582277	16-03-89
		AU-A- 6359586	30-04-87
		CA-A- 1259893	26-09-89
		JP-A- 62121655	02-06-87