

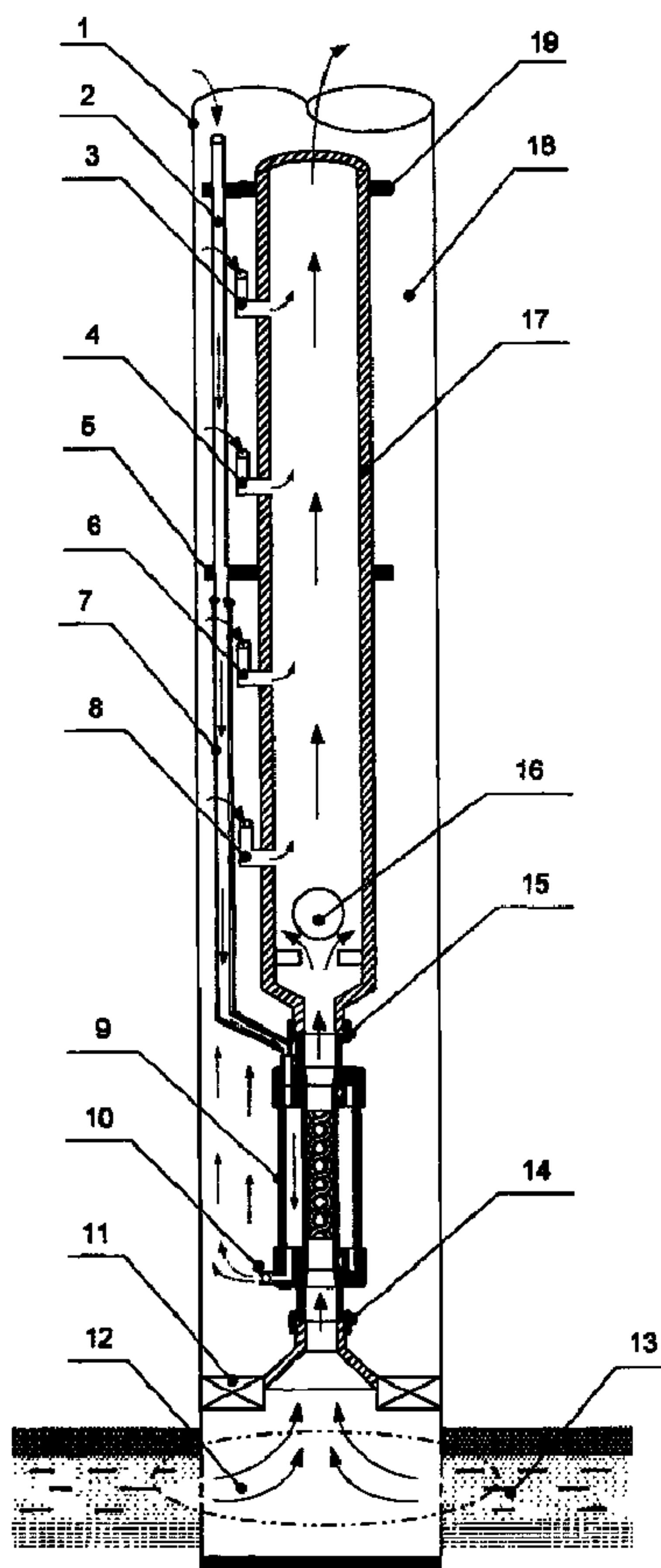

(86) Date de dépôt PCT/PCT Filing Date: 2002/10/11
 (87) Date publication PCT/PCT Publication Date: 2003/05/30
 (45) Date de délivrance/Issue Date: 2010/05/11
 (85) Entrée phase nationale/National Entry: 2004/04/05
 (86) N° demande PCT/PCT Application No.: HR 2002/000047
 (87) N° publication PCT/PCT Publication No.: 2003/044318
 (30) Priorité/Priority: 2001/10/12 (HR P20010739 A)

(51) Cl.Int./Int.Cl. *E21B 43/12* (2006.01),
F04D 13/04 (2006.01)
 (72) Inventeur/Inventor:
MATIC, JURAJ, HR
 (73) Propriétaire/Owner:
NIZETIC, TOMISLAV, HR
 (74) Agent: SMITHS IP

(54) Titre : TURBINE A GAZ POUR L'EXTRACTION DE PETROLE
 (54) Title: GAS TURBINE FOR OIL LIFTING



(57) Abrégé/Abstract:

Gas turbine driven oil lifting device represents a device for increasing the quantity of oil obtained in the unit of time and the percentage of total amount obtained from oil bearing geological deposits. The device is installed in technical column (1) and

(57) **Abrégé(suite)/Abstract(continued):**

consists of sections (12) and (18), separated by a bypass packer (11), on which gas turbine (9) is fixed by coupling (14), and tubing (17) with valves (3), (4), (6), (8) is fixed to the turbine (9) by coupling (15). Above the gas turbine (9) a check valve (16) is installed in the tubing (17). Parallel with the tubing (17), a supply tube of the turbine (2) is fixed by couplings (5) and (19), and is by its bottom end connected to the opening (20) at the upper head (34) of the gas turbine (9) by a flexible hose (7). The device may operate continually and periodically. It may be applied for recovery of liquids from all the liquid bearing geological deposits, having insufficient pressure for natural flow.

(12) INTERNATIONAL APPLICATION PUBLISHED UNDER THE PATENT COOPERATION TREATY (PCT)

(19) World Intellectual Property Organization
International Bureau(43) International Publication Date
30 May 2003 (30.05.2003)

PCT

(10) International Publication Number
WO 03/044318 A1

- (51) International Patent Classification⁷: E21B 43/12, F04D 13/04
- (71) Applicant and
(72) Inventor: MATIC, Juraj [HR/HR]; Malo Trojstvo 12, 43226 Veliko Trojstvo (HR).
- (21) International Application Number: PCT/HR02/00047
- (74) Common Representative: NIZETIC, Tomislav; Antuna Augustincica 13, 10000 Zagreb (HR).
- (22) International Filing Date: 11 October 2002 (11.10.2002)
- (25) Filing Language: Croatian
- (81) Designated States (*national*): AE, AG, AL, AM, AT, AU, AZ, BA, BB, BG, BR, BY, BZ, CA, CH, CN, CO, CR, CU, CZ, DE, DK, DM, DZ, EC, EE, ES, FI, GB, GD, GE, GH, GM, HU, ID, IL, IN, IS, JP, KE, KG, KP, KR, KZ, LC, LK, LR, LS, LT, LU, LV, MA, MD, MG, MK, MN, MW, MX, MZ, NO, NZ, OM, PH, PL, PT, RO, RU, SD, SE, SG, SI, SK, SL, TJ, TM, TN, TR, TT, TZ, UA, UG, US, UZ, VN, YU, ZA, ZM, ZW.
- (26) Publication Language: English
- (84) Designated States (*regional*): ARIPO patent (GH, GM, KE, LS, MW, MZ, SD, SL, SZ, TZ, UG, ZM, ZW), Eurasian patent (AM, AZ, BY, KG, KZ, MD, RU, TJ, TM),
- (30) Priority Data: P20010739 A 12 October 2001 (12.10.2001) HR
- (71) Applicants (*for all designated States except US*): NIZETIC, Tomislav [HR/HR]; Antuna Augustincica 13, 10000 Zagreb (HR). KEGLEVIC, Kresimir [HR/HR]; Durmitorska 28 A, 10000 Zagreb (HR).

[Continued on next page]

(54) Title: GAS TURBINE FOR OIL LIFTING

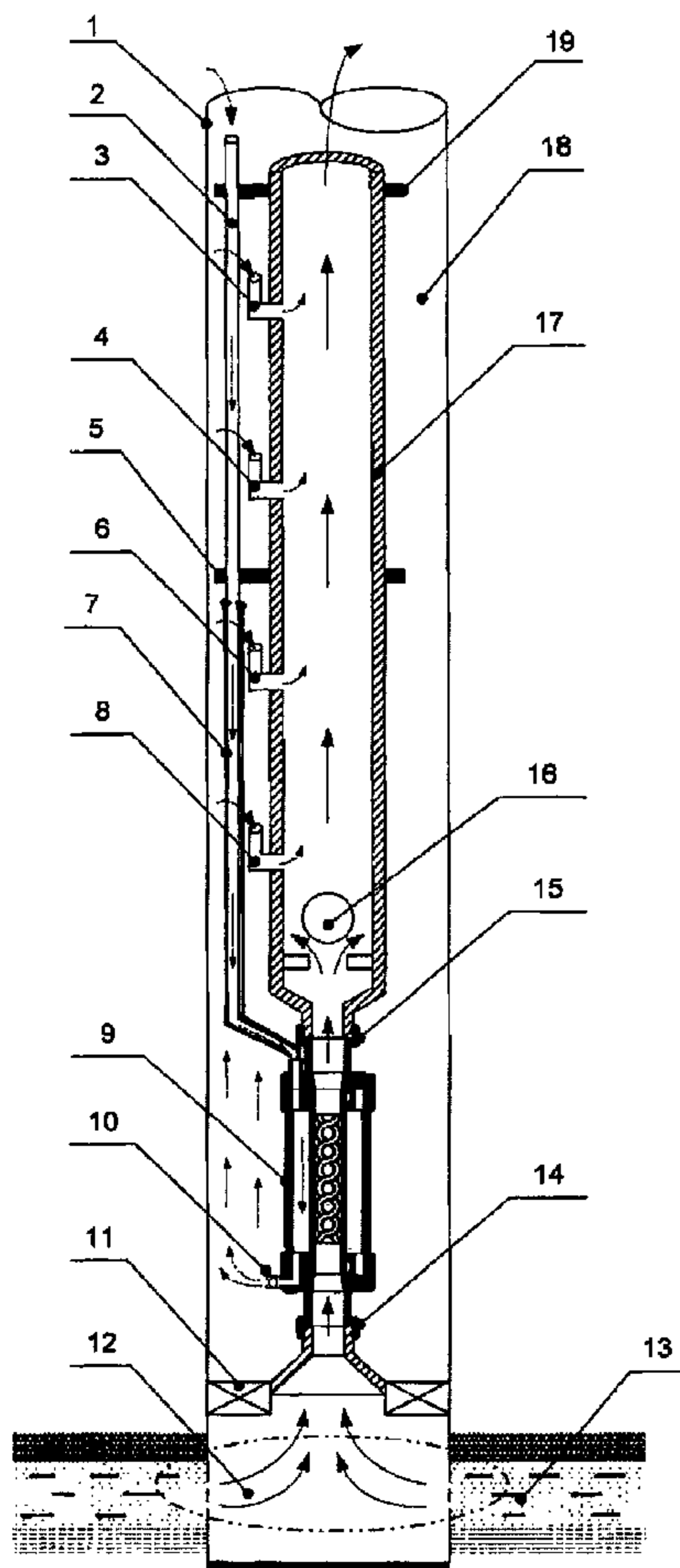

(57) Abstract: Gas turbine driven oil lifting device represents a device for increasing the quantity of oil obtained in the unit of time and the percentage of total amount obtained from oil bearing geological deposits. The device is installed in technical column (1) and consists of sections (12) and (18), separated by a bypass packer (11), on which gas turbine (9) is fixed by coupling (14), and tubing (17) with valves (3), (4), (6), (8) is fixed to the turbine (9) by coupling (15). Above the gas turbine (9) a check valve (16) is installed in the tubing (17). Parallel with the tubing (17), a supply tube of the turbine (2) is fixed by couplings (5) and (19), and is by its bottom end connected to the opening (20) at the upper head (34) of the gas turbine (9) by a flexible hose (7). The device may operate continually and periodically. It may be applied for recovery of liquids from all the liquid bearing geological deposits, having insufficient pressure for natural flow.

WO 03/044318 A1

WO 03/044318 A1



European patent (AT, BE, BG, CH, CY, CZ, DE, DK, EE, ES, FI, FR, GB, GR, IE, IT, LU, MC, NL, PT, SE, SK, TR), OAPI patent (BF, BJ, CF, CG, CI, CM, GA, GN, GQ, GW, ML, MR, NE, SN, TD, TG).

For two-letter codes and other abbreviations, refer to the "Guidance Notes on Codes and Abbreviations" appearing at the beginning of each regular issue of the PCT Gazette.

Published:

— *with international search report*

GAS TURBINE FOR OIL LIFTING

TECHNICAL FIELD OF THE INVENTION

The invention relates to the field of oil production, and in particular to the recovery of oil
5 from deep wells.

According to the International Patent Classification (IPC) the subject matter of the invention is classified under E 21 B 4/00 and E 21 B 43/00, defining methods or apparatus for obtaining oil, gas, water and soluble materials from deep wells.

10 TECHNICAL PROBLEM

The technical problem to be solved by this invention comprises the following: how to increase the quantity of oil obtained in the unit of time from bore holes incurring appreciable decrease of deposit natural energy, and how to increase the percentage of oil quantity obtained from drainage zones of such bore holes, simultaneously maintaining control over production
15 parameters.

STATE OF THE ART

Processes for increasing production in the unit of time and percentage of oil quantity obtained from oil bearing deposits, used so far, may be divided into chemical, biological and
20 mechanical processes. Chemical processes include the injection of various chemical agents in the oil bearing deposit, to decrease oil viscosity and facilitate it to flow into the bore hole.

Biological processes include the injection of microorganisms in the oil bearing deposit, where the replication and metabolism products thereof increase the oil deposit pressure and decrease the viscosity of oil.

25 Mechanical processes include processes for the enlargement of the drainage zone, processes for the increase of the oil deposit pressure and devices for pumping the oil from bore holes.

Processes for the enlargement of the drainage zone include hydraulic fracturing processes and making of horizontal bores.

Processes for increasing deposit pressure are gas drive and water drive recovery.

30

- 2 -

Devices used for recovery of oil from bore holes having pressure insufficient for natural flow are: bore hole pump, bore hole centrifugal pump, screw suction pump, diaphragm suction pump and gas driven lifting device, that may be of permanent type, periodical type – type of piston lift and chamber lift and device for recovery of oil fluid from deep wells, patent HR P920143. The disadvantage of the abovementioned solutions, including a device for recovery of oil fluid from deep wells is that any of those solutions, used individually, doesn't increase production dynamics or percentage of oil quantity obtained from the oil bearing deposits, maintaining control over production process. The additional disadvantage of the solution presented as a device for recovery of oil fluid from deep wells is complex installation and continuous operation, while the quantity obtained in the unit of time is small and restricted by dynamic pressure, generated by such an operating regime without damaging the oil bearing deposit.

The aim of the solution according to this application is to construct such a device which will increase production in the unit of time and percentage of oil quantity obtained from the oil bearing deposit, while using very little energy and maintaining control over production.

DESCRIPTION OF THE SOLUTION TO THE TECHNICAL PROBLEM

The defined technical problem is solved by the gas turbine driven oil lifting device from deep wells.

The structural design of the gas turbine driven oil lifting device provides for the division of production column – casing (1) in two parts, connected by a bypass packer (11). The gas turbine (9) is fixed above the packer (11), and the tubing (17) is fixed above the gas turbine (9). Above the turbine (9), a check valve is set in the tubing (17), and above the check valve (16), equipment for gas driven lifting of oil fluid, consisting of several valves (3), (4), (6), (8) having various opening pressures is installed on the tubing (17). The opening pressure of the valve (8), which is next to the turbine, is the lowest one, while the pressure of each subsequent valve is higher. In the ring-shaped area (18), between the tubing (17) and the casing (1), there is the turbine supply tube (2), which fixed to the tubing (17) by collars (5) and (19). The bottom end of the turbine supply tube (2) is fixed to the gas turbine (9) rotor inlet (20) by a flexible hose.

- 3 -

Structural connection of elements, carried out in the abovementioned manner, allows gas to be driven, by means of a compressor, through the turbine supply tube (2) to the gas turbine (20), starting to revolve it. The gas is driven out from the gas turbine (28) through a check valve (10) entering the ring area (18) between the tubing (17) and casing (1). Turbine blades (24) allow rotation of the rotor (32) that contains a rotary pump (25).

Rotation of rotary pump (25) that is immersed in oil, drives oil upwards into the tubing (17). Introduction of gas in the ring area (18) causes pressure increase in it and opening of the bottom valve (8), the opening pressure of which determines the difference between the turbine inlet and outlet pressures. Gas enters through it into the tubing (17), mixes with oil and therewith facilitates the oil to be lifted.

The increased pressure in the ring area (18), generated by a higher oil level in the tubing (17), opens in turn, where the opening pressures are achieved, upper valves (6), (4), (3), adjusted to higher opening pressures, starting to release the gas flow into the tubing (17), making the oil in it lighter, and helping it to raise to the surface.

During the turbine operation (9), the check valve (16) is open, enabling free flow of gas upwards. When the introduction of gas stops, the turbine (9) stops, and the pressure of oil left in the tubing (17) presses to the check valve (16), and closes it. Turbine rotations, during its operation, generate appreciable negative pressure, which extends to the oil bearing deposit (13). Check valve (16) separates hermetically the negative pressure zone (12) and the tubing (17), preventing oil from flowing back to the area of lowered pressure (12) under the valves, and enabling increased flow of oil from the oil bearing deposit (13) to the area of negative pressure (12). Owing to great difference between the pressures of the zone of the bore hole (12) and adjacent area (13) which is lower, and the area distant from the bore hole in which the turbine operation (9) didn't appreciably decrease the pressure, the flow of oil from the distant areas into the bore hole (12) and adjacent area, is increased and accelerated. The increase of pressure in the area (12) under the check valve, generated by inflow of oil from the oil bearing deposit and distant areas, during the turbine rest, and its increase, exceeding the pressure of the hydrostatic column above the check valve (16), causes the check valve in the tubing (17) to open and allow a free inflow of oil through the turbine (9) and upwards. After the pressures are leveled and the column of oil in tubing (17) stopped to increase, gas introduced through a turbine supply tube (2) to the turbine inlet (20) puts the turbine (9) into

- 4 -

operation and lifts oil. The cycle repeats. Such an operation of the turbine (9), check valve (16) and valves (3), (4), (6), (8), for gas driven lifting device, increases the amount of oil
5 obtained in the unit of time, and the oil quantity obtained in total, from deposits saturated with liquid hydrocarbons (13), maintaining at the same time control over production parameters.

Check valve (10) on the turbine outlet (28) is intended to prevent the entry of fluids into the turbine, during the well completion process.

This is the main advantage of the invention.

10

DESCRIPTION OF THE DRAWINGS

The invention is described in more details in the example of carrying it out, shown in the drawings in which:

Figure 1 shows the scheme of the gas turbine driven lifting device according to the invention

15 Figure 2 shows ground plan of the gas turbine

Figure 3 shows cross section of A-A gas turbine

Gas turbine driven lifting device consists of production column - casing (1), which is divided into two sections (12) and (18) by a bypass packer (11). In section (18), gas turbine (9) is fixed to the bypass packer (11) by a coupling (14). The tubing (17) is fixed to the gas turbine
20 (9) by a coupling (15). A check valve (16) is set in the tubing (17) above the turbine (9). The tubing (17) has, above the check valve (16), spindle valves (3), (4), (6) and (8), set one above the other. Parallel with the inlet tube (17) there is a turbine supply tube (2), which is fixed to inlet tube (17) by stabilizing collars (5) and (19). Turbine supply tube (2) is fixed to the gas turbine by flexible hose (7). Gas turbine (9) consists of rotor (32), which has blades (24) on
25 the outer side, and rotary pump (25) inside. Rotor (32) of the turbine (9) is set in the cylinder (23) on the upper part of which upper head with openings (20) and (35) is screwed in, and on the bottom part, bottom head (30) with openings (28) and (29) and check valve (10) which is set at the outlet of the turbine (28). The rotor (32) is rotationally embedded in its upper part in the bearing (22), sealed by shaft seals (33), and in the bottom bearing (26) sealed with shaft
30 seals (27). Gas turbine has a coupling (15) on its upper side, and a coupling (14) on its bottom side. In casing (1), gas turbine is fixed to bypass packer (11) by coupling (14), and to tubing (17) by coupling (15).

METHOD FOR CARRYING THE INVENTION OUT

The device operates in the way such as follows: gas under pressure is driven from the compressor through a supply tube of the turbine (2), which is connected by a flexible pipe (7) to the opening (20) of the upper head (34), then enters the cylinder (23), and activates the blades (24) that rotate the rotor (32). Rotary pump (25) that is immersed in oil is rotating together with the rotor (32). By its rotation, rotary pump (25) drives oil from bottom part of casing (12...) into tubing (17). Gas leaves the cylinder through an opening (28) in the lower head (30), and enters the ring area (18), which is hermetically closed on its upper and lower side. Increase of gas pressure in the ring area (18) opens valves (3), (4), (6), (8). Valve (8), serving also as a regulator of difference between the turbine pressure and flow through the turbine. It is adjusted to the lowest opening pressure. Possible further increase of pressure in the ring area (18) opens in turn valves (6), (4) and (3).

Valves open and close automatically, depending on opening pressures, which they are adjusted to. Opening of the valves in such a way allows gas to enter from the ring area (18) into tubing (17) and lift oil, decreasing the pressure of oil affecting the gas turbine (9) and the worm. Gas turbine (9) starts to rotate faster and lifting larger quantity of oil. When supply of gas through a turbine supply tube (2) stops, the turbine (9) stops to operate momentarily.

Check valve (16) that has been open during the turbine operation, closes owing to pressure of hydrostatic column in the tubing (17), hermetically separating the area of low pressure (12), created by turbine operation (9), from the upper part of the tubing (17). Owing to pressure difference oil flows from the distant parts of the deposit to the area of lower pressure (12), created by turbine operation. After a certain time, owing to inflow of oil to the area of lower pressure (12), the pressure in the area (12) increases, and if it exceeds the pressure of hydrostatic column in the tubing (17), the check valve (16) opens and allows free flow of oil through the turbine (9). With new introduction of gas in the turbine (9), the turbine (9) starts to operate, and the cycle repeats.

Check valve (10) at the turbine outlet (28) prevents fluid from entering the turbine during the well completion process.

INDUSTRIAL APPLICATION OF THE INVENTION

5 The invention is intended to increase the recovery of liquids from liquid bearing geological deposits, such as recovery of oil or water from deep wells, particularly in the cases of partial depletion of deposits, where, owing to the deposit low pressure, natural flow is missing. The intention is to increase the quantity of oil obtained from the deposit in the unit of time, and to increase the percentage of total quantity of liquid obtained from the deposit, using the least energy possible.

10 The application of the technical solution according to this invention includes usual procedures, equipment and material, provided that the staff is additionally trained for controlling and handling of the equipment.

Safety working measures are of standard type, and are not environmentally dangerous.

15 This solution provides for periodical turbine operation on high velocity rotation resulting in a large quantity of liquid recovered in a short period of time and creation of low pressure in bore hole areas, extending to oil bearing deposit.

CLAIMS

1. Gas turbine driven oil lifting device, said device being intended to increase production of oil in the unit of time and percentage of the oil quantity obtained from an oil bearing deposit (13), in particular from bore holes incurring appreciable decrease of deposit
5 natural energy, the device being installed in the production column-casing (1), consisting of tubing (17), bypass-packer (11), valves (3, 4, 6, 8), check valves (16, 10), gas turbine (9), couplings (14, 15), collars (5, 19), tube (2), flexible hose (7) and rotary pump (25), the production column-casing (1) consisting of sections (12) and (18), separated by a bypass packer (11), while the gas turbine (9) is fixed to the bypass packer (11) by coupling (14),
10 the tubing (17) with valves (3, 4, 6, 8) is fixed to the gas turbine (9) by coupling (15), and above the gas turbine (9) and above the check valve (16), valve (8) is installed in the tubing (17), the supply tube (2) of the gas turbine (9) is fixed along the tubing (17) by stabilizing collars (5, 19), ending in flexible hose (7), entering the gas turbine (9) at the upper head (20), while check valve (10) is installed at the turbine outlet (28), and wherein
15 the rotary pump (25) is contained in the gas turbine (9) for rotation therewith, characterized in that opening of the valves (3, 4, 6, 8) allows gas leaving the turbine (9) to enter into the tubing (17).
2. Gas turbine driven oil lifting device according to claim 1, characterized by the fact, that
20 the bypass-packer (11) and the check valve (16) separate hermetically sections (12) and (18).
3. Gas turbine driven oil lifting device according to claim 1, characterized by the fact, that
25 check valve (10) is installed at the turbine outlet, preventing the entry of fluid in the turbine during the well completion process.
4. Gas turbine driven oil lifting device according to claim 1, characterized by the fact, that
30 check valve (16), preventing return of oil through the turbine (9) to area (12), is installed in the tubing above the turbine (9) and below valve (8).
5. The process of adjusting the device according to claim 1, characterized by the fact, that the difference between the opening pressures of the system of valves (3, 4, 6, 8) on tubing (17) must be adjusted to be as follows: the opening pressure of the valve (8) next to the

gas turbine (9) shall be the lowest, the opening pressure of each subsequent valve (6, 4, 3) shall be higher than the opening pressure of the valve below it.

- 5 6. Process of adjusting the device according to claim 1, characterized by the fact, that the adjusting of opening pressure of valve (8), next to the turbine (9), under constant pressure of gas from the surface, adjusts the difference between the turbine inlet and outlet pressures, and adjustment of flow through valve (8) adjusts the flow of gas through the turbine (9) in the unit of time.
- 10 7. The application of the device according to claims 1 and 2, characterized by the fact, that apart from the continuous operation, periodical operation of the gas turbine driven oil lifting device may be applied, said periodical operation comprising the steps of:
 - allowing operation of the gas turbine (9) at high velocity of rotary pump (25) rotation, resulting in a large amount of oil lifted in a short period of time, and in the generation of negative pressure area (12) after the termination of the gas turbine (9) operation and closing of check valve (16), and
 - 15 - separating the area (12), that extends to parts of the layer near to the bore hole, from the tubing (17) by means of said check valve (16).
- 20 8. Gas turbine driven oil lifting device according to claim 1, characterized by the fact, that the rotary pump (25) is fixed into the rotor (32) of the gas turbine (9) by a warm-cold method.
- 25 9. Application of the gas turbine driven oil lifting device according to any one of claims 1 to 4 and 8 for recovery of liquids from liquid bearing geological deposits having deposit pressure insufficient for natural flow.
- 30 10. Application of the process according to any one of claims 5 and 6 for recovery of liquids from liquid bearing geological deposits having deposit pressure insufficient for natural flow.

11. The application according to claim 7, wherein said application is for recovery of liquids from liquid bearing geological deposits having deposit pressure insufficient for natural flow.

1/3

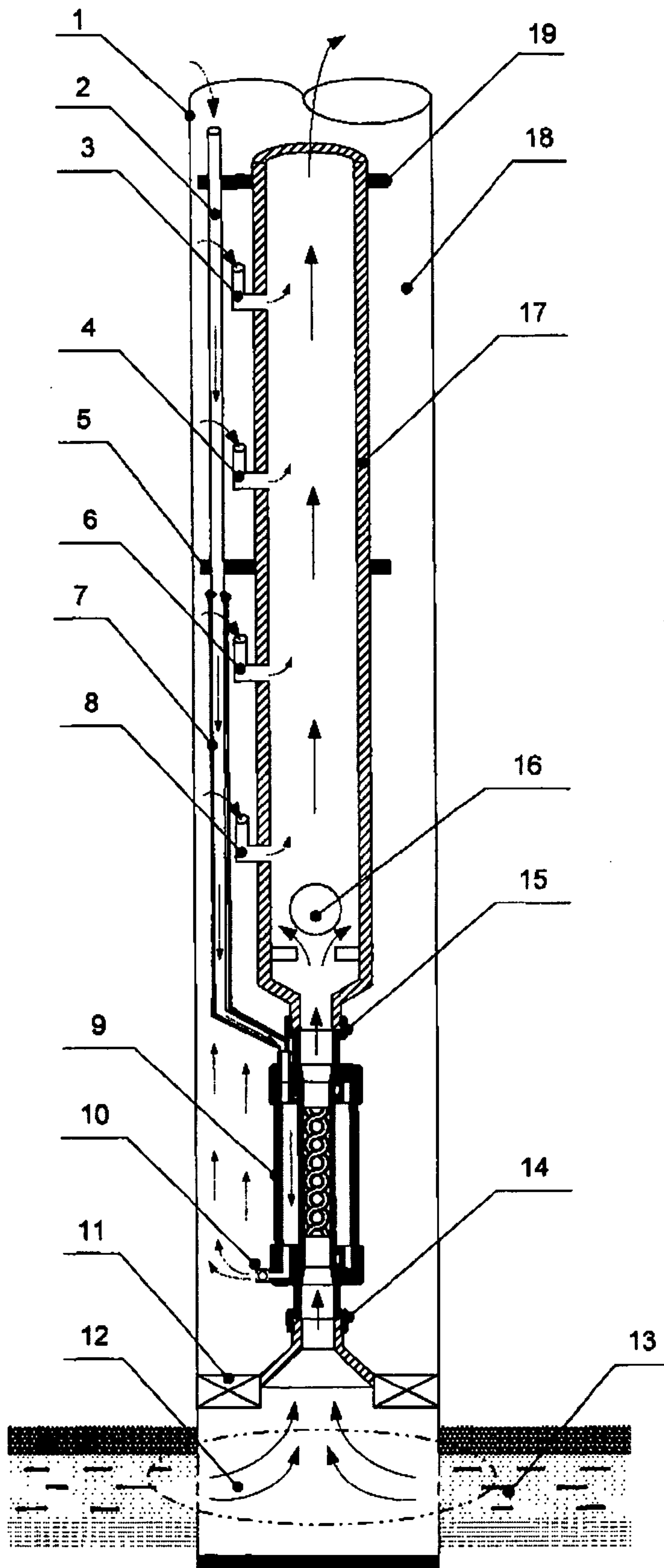

Fig. 1

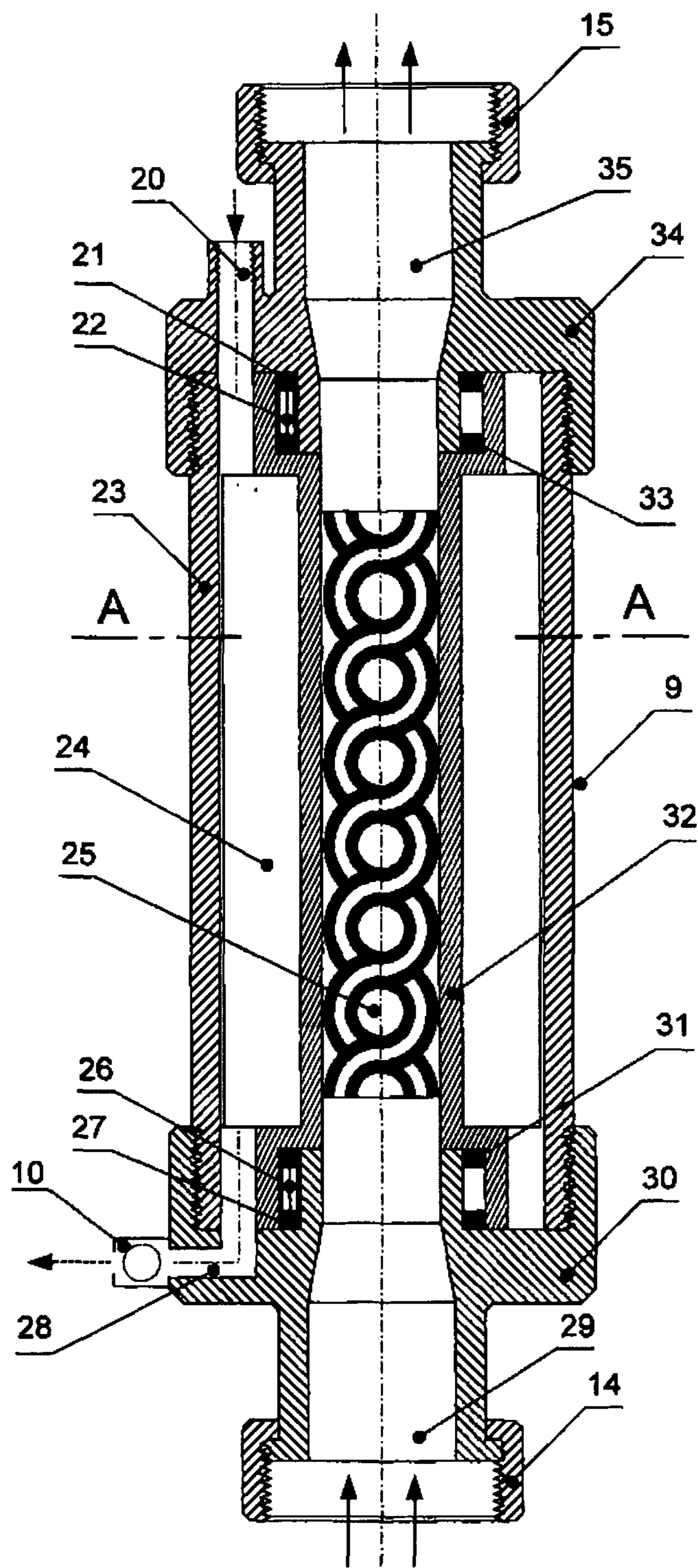

Fig. 2

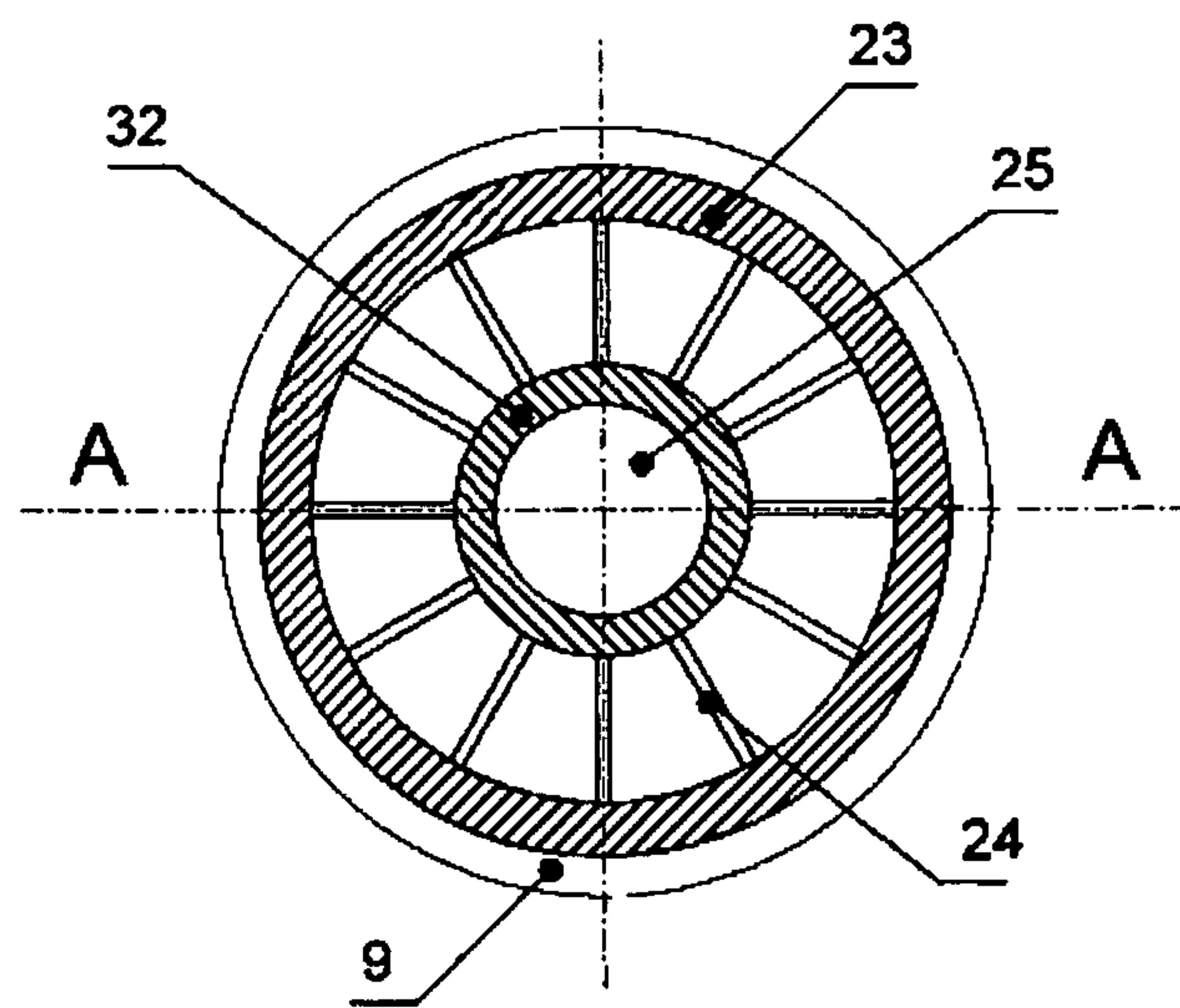

Fig. 3

