

No. 689,092.

Patented Dec. 17, 1901.

M. F. KENELY.  
BOILER.

(Application filed July 31, 1901.)

(No Model.)

2 Sheets—Sheet 1.

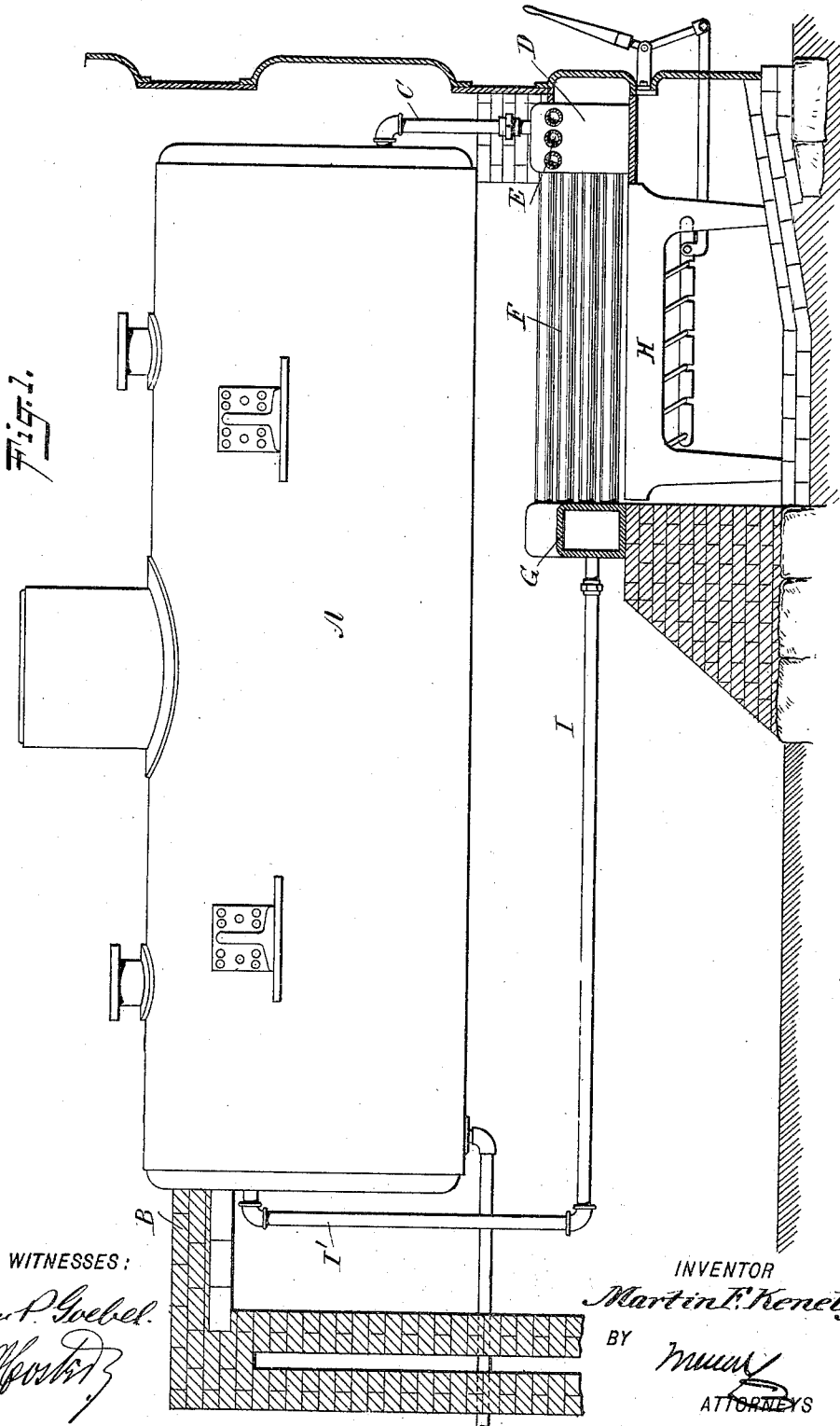

WITNESSES:

*William P. Goebel.*  
*Geo. H. Hester.*

INVENTOR

*Martin F. Kenely*

BY

*Munn*  
ATTORNEYS

No. 689,092.

Patented Dec. 17, 1901.

M. F. KENELY.  
BOILER.

(Application filed July 31, 1901.)

(No Model.)

2 Sheets—Sheet 2.

Fig. 2.

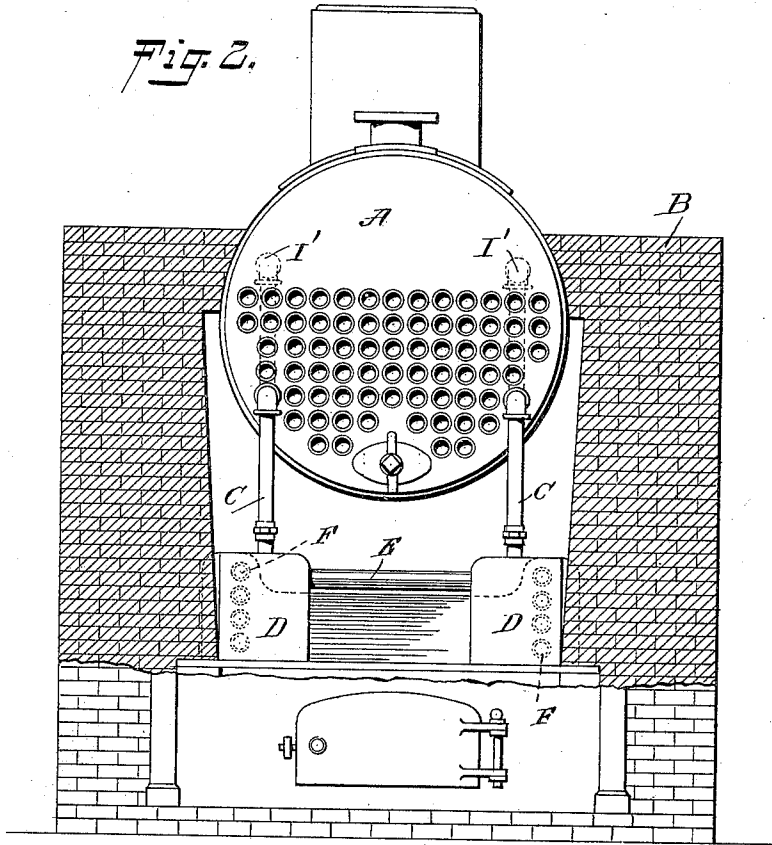
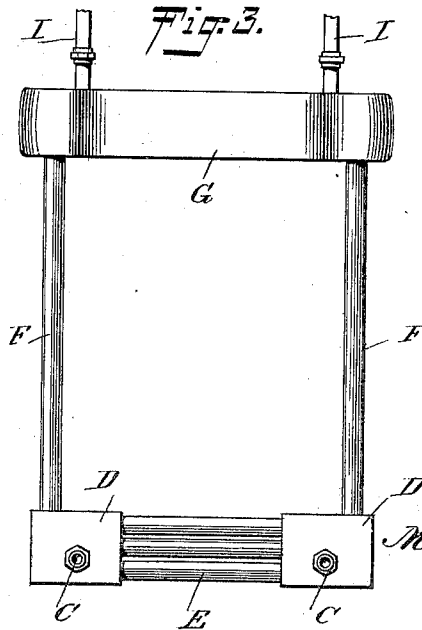

Fig. 3.



WITNESSES:

*William P. Laebel.*  
*Rev. G. H. Smith.*

INVENTOR

*Martin F. Kenely*

BY

*Mum*  
ATTORNEYS

# UNITED STATES PATENT OFFICE.

MARTIN F. KENELY, OF ELIZABETH, NEW JERSEY.

## BOILER.

SPECIFICATION forming part of Letters Patent No. 689,092, dated December 17, 1901.

Application filed July 31, 1901. Serial No. 70,373. (No model.)

To all whom it may concern:

Be it known that I, MARTIN F. KENELY, a citizen of the United States, and a resident of Elizabeth, in the county of Union and State of New Jersey, have invented a new and Improved Boiler, of which the following is a full, clear, and exact description.

The object of the invention is to provide a new and improved boiler arranged to insure a rapid circulation and heating of the water for quickly generating steam and to utilize the fuel employed to the greatest advantage and with economy.

The invention consists of novel features and parts and combinations of the same, as will be fully described hereinafter and then pointed out in the claims.

A practical embodiment of the invention is represented in the accompanying drawings, forming a part of this specification, in which similar characters of reference indicate corresponding parts in all the views.

Figure 1 is a longitudinal sectional elevation of the improvement. Fig. 2 is a front elevation of the same with part of the front removed, and Fig. 3 is a plan view of the water-heating chambers forming the walls of the fire-box.

The shell A is set in the usual manner in the brickwork B, and the water-compartment in said shell A is connected at its front end by downwardly-extending pipes C with the corner water-chambers D, connected with each other by a horizontal row of transverse pipes E, entering the chambers D at or near the tops thereof, as is plainly indicated in Fig. 2, so as to leave sufficient space below the pipes for feeding the fuel to the fire-box. The corner chambers D are connected by horizontal rows of pipes F with a bridge-wall chamber G, it being understood that said chambers D G and pipes E F form the walls of the fire-box, arranged over the grate H, the bridge-wall chamber G also forming the bridge-wall for the fire-box. From the rear ends of the bridge-wall chamber G extend rearwardly the pipes I, connected at their rear ends I' with the rear end of the shell A, at the steam-compartment thereof. Now it will be seen that when the fuel is burning in the fire-box the heat emanating from the burning fuel thoroughly heats the walls of

the fire-box—that is, the chambers D G and the pipes E F—so that the water therein is highly heated and readily flows through the pipes I into the steam-compartment of the shell A at the rear thereof. The water in the front end of the shell A returns by the pipes C to the corner chambers D and is thoroughly subjected to heat, so that a proper circulation of the water from the boiler through the fire-box and back into the boiler is insured to cause a very rapid generation of steam. By the arrangement described a fire-box formed in the manner set forth is not liable to burn out, as is so frequently the case with fire-boxes heretofore constructed and mainly composed of fire-brick and the like.

The chambers D, as well as the bridge-wall chamber G, are provided with suitable man-holes for cleaning the chambers and the pipes E F whenever desired.

Having thus fully described my invention, I claim as new and desire to secure by Letters Patent—

1. In a boiler, the combination with a shell, of a bridge-wall chamber connected therewith, corner chambers at the front of the boiler-grate, two sets of pipes connecting the corner chambers with the bridge-wall chambers and forming the sides of a combustion-chamber, and another set of pipes connecting the corner chambers and arranged in connection with the front of the boiler, to form a fuel-inlet opening to the combustion-chamber.

2. A boiler having a fire-box, comprising corner water-chambers connected with the water-compartment of the boiler-shell, a bridge-wall chamber forming the bridge-wall of the fire-box, and connected with the steam-compartment of the boiler-shell, a horizontal row of pipes connecting the corner chambers with each other at or near the tops thereof, and vertical rows of pipes connecting the corner water-chambers with the bridge-wall chamber, as set forth.

In testimony whereof I have signed my name to this specification in the presence of two subscribing witnesses.

MARTIN F. KENELY.

Witnesses:

EDWARD NUGENT,  
GEORGE F. MCCANDLESS.