

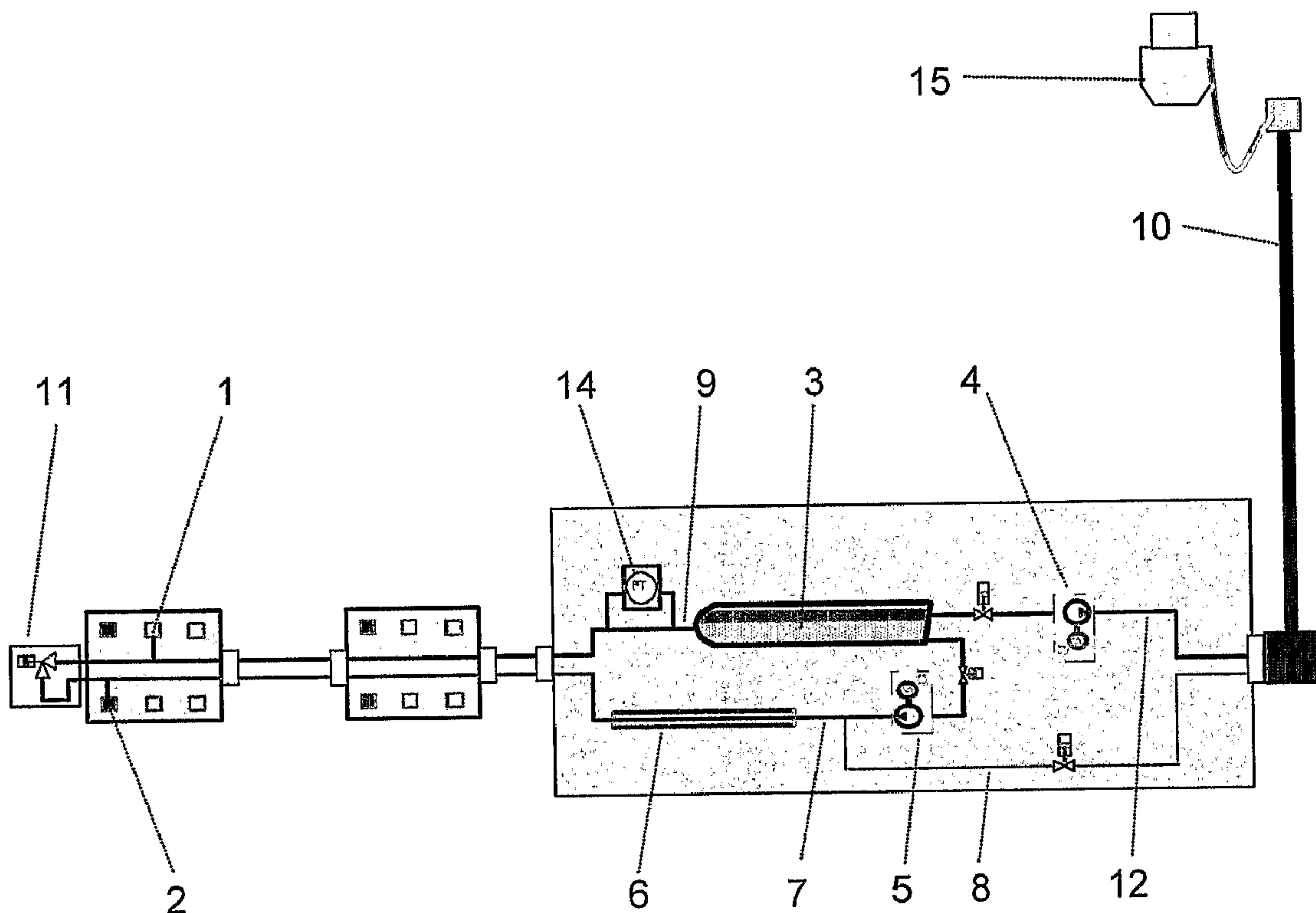

(86) Date de dépôt PCT/PCT Filing Date: 2007/10/19  
 (87) Date publication PCT/PCT Publication Date: 2008/05/02  
 (45) Date de délivrance/Issue Date: 2015/07/07  
 (85) Entrée phase nationale/National Entry: 2009/03/04  
 (86) N° demande PCT/PCT Application No.: NO 2007/000373  
 (87) N° publication PCT/PCT Publication No.: 2008/051087  
 (30) Priorité/Priority: 2006/10/27 (NO20064918)

(51) Cl.Int./Int.Cl. *E21B 43/01* (2006.01),  
*E21B 36/00* (2006.01), *E21B 43/40* (2006.01)  
 (72) Inventeur/Inventor:  
BAKKE, WILLIAM, NO  
 (73) Propriétaire/Owner:  
STATOIL PETROLEUM AS, NO  
 (74) Agent: FETHERSTONHAUGH & CO.

(54) Titre : SYSTEME DE TRAITEMENT SOUS-MARIN  
 (54) Title: SUB SEA PROCESSING SYSTEM



(57) **Abrégé/Abstract:**

Sub-sea processing system for the production of oil and/or gas from one or more production wells (1), especially wells producing heavy oil on deep water and with high viscosity. The system includes, beyond the production well/s (1), one or more injection wells (2) for the injection of produced water, a separator (3), a production pump (4), a water injection and circulation pump (5) and a heating arrangement (6). A water circulation and injection pipe loop (7) is provided to interconnect the separator (3), the injection and circulation pump (5), the heating arrangement (6), the flow control device (11) and the wells (1, 2) enabling circulation of heated water to the wells (1,2) via the separator (3) and heating arrangement (6).

(12) INTERNATIONAL APPLICATION PUBLISHED UNDER THE PATENT COOPERATION TREATY (PCT)

(19) World Intellectual Property Organization  
International Bureau(43) International Publication Date  
2 May 2008 (02.05.2008)

PCT

(10) International Publication Number  
**WO 2008/051087 A1**

## (51) International Patent Classification:

*E21B 43/01* (2006.01)      *E21B 43/40* (2006.01)  
*E21B 36/00* (2006.01)

## (21) International Application Number:

PCT/NO2007/000373

## (22) International Filing Date: 19 October 2007 (19.10.2007)

(25) Filing Language: English

(26) Publication Language: English

## (30) Priority Data:

20064918      27 October 2006 (27.10.2006)      NO

(71) Applicant (for all designated States except US): **NORSK HYDRO ASA** [NO/NO]; N-0240 Oslo (NO).

## (72) Inventor; and

(75) Inventor/Applicant (for US only): **BAKKE, William** [NO/NO]; Lyngåsveien 15, N-3440 Royken (NO).(74) Agent: **HOV, Espen**; Tandbergs Patentkontor AS, P.O. Box 7085 Majorstuen, N-0306 Oslo (NO).

(81) Designated States (unless otherwise indicated, for every kind of national protection available): AE, AG, AL, AM, AT, AU, AZ, BA, BB, BG, BH, BR, BW, BY, BZ, CA, CH, CN, CO, CR, CU, CZ, DE, DK, DM, DO, DZ, EC, EE, EG, ES, FI, GB, GD, GE, GH, GM, GT, HN, HR, HU, ID, IL, IN, IS, JP, KE, KG, KM, KN, KP, KR, KZ, LA, LC, LK, LR, LS, LT, LU, LY, MA, MD, ME, MG, MK, MN, MW, MX, MY, MZ, NA, NG, NI, NO, NZ, OM, PG, PH, PL, PT, RO, RS, RU, SC, SD, SE, SG, SK, SL, SM, SV, SY, TJ, TM, TN, TR, TT, TZ, UA, UG, US, UZ, VC, VN, ZA, ZM, ZW.

(84) Designated States (unless otherwise indicated, for every kind of regional protection available): ARIPO (BW, GH, GM, KE, LS, MW, MZ, NA, SD, SL, SZ, TZ, UG, ZM, ZW), Eurasian (AM, AZ, BY, KG, KZ, MD, RU, TJ, TM), European (AT, BE, BG, CH, CY, CZ, DE, DK, EE, ES, FI, FR, GB, GR, HU, IE, IS, IT, LT, LU, LV, MC, MT, NL, PL, PT, RO, SE, SI, SK, TR), OAPI (BF, BJ, CF, CG, CI, CM, GA, GN, GQ, GW, ML, MR, NE, SN, TD, TG).

## Published:

— with international search report

## (54) Title: SUB SEA PROCESSING SYSTEM

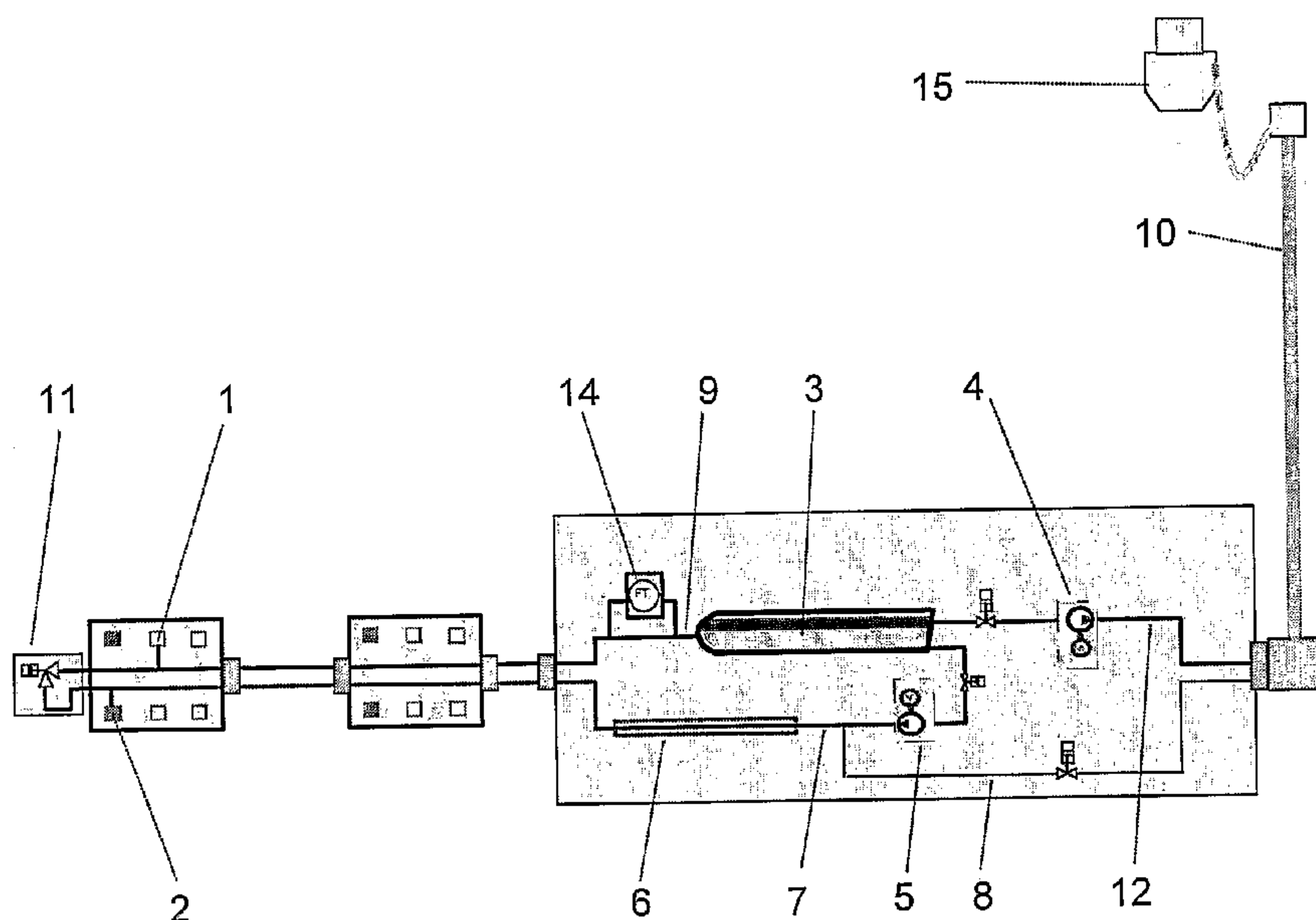

(57) Abstract: Sub-sea processing system for the production of oil and/or gas from one or more production wells (1), especially wells producing heavy oil on deep water and with high viscosity. The system includes, beyond the production well/s (1), one or more injection wells (2) for the injection of produced water, a separator (3), a production pump (4), a water injection and circulation pump (5) and a heating arrangement (6). A water circulation and injection pipe loop (7) is provided to interconnect the separator (3), the injection and circulation pump (5), the heating arrangement (6), the flow control device (11) and the wells (1, 2) enabling circulation of heated water to the wells (1,2) via the separator (3) and heating arrangement (6).

WO 2008/051087 A1

5

10

Sub sea processing system

15

The present invention relates to a sub sea processing system in connection with the production of oil and/or gas from one or more wells, especially wells producing heavy oil in deep water and with high viscosity.

20

Oil and gas sub-sea field developments in deeper waters and closer to arctic areas face various technical challenges as a result of the more hostile environmental conditions.

Overcoming these challenges requires a combination of careful and innovative design of production systems, and extensive and tightly controlled multi-phase flow assurance, as well as operational strategies and procedures. Design of sub-sea production systems

25

normally begins with fluid characterization followed by establishment of a field architecture and development of economical flow-line configurations consistent with safety and minimum intervention requirements. Understanding and designing for the various flow assurance conditions and requirements of the deep water system may lead

30

to minimum intervention and least possible production loss. The performance goal for steady state operations should be to achieve platform arrival temperatures above hydrate formation temperatures and/or wax appearance temperature (WAT) as a minimum. The performance goal for transient, i.e. shut-in, operations is to achieve adequate, cool-down time before the pipe contents cool to the hydrate formation

32137-2

2

temperature after shut-in. Besides shut-in, depressurization and wax removal come into play as other major transient challenges in deeper waters.

Sub-sea pipeline bundles are commonly known and represents enhanced pipeline systems for the transportation of oil and gas and remote operation of sub-sea oil and gas wells. Such bundles may include a carrier pipe (outer casing or shell), within  
5 which may be provided one or more flow-lines for oil and gas, pipeline(s) or other arrangement for heating as well as hydraulic and/or electric control lines for the remote operation of the wells. This bundle solution may provide highly efficient thermal insulation and/or active heating elements to minimize thermal losses.

10 Bundle solutions are commonly used, among other situations, where operation takes place on deep water, where seabed areas are congested, where diverless operations are mandatory or where anchor patterns restrict available seabed. However, bundle solutions as such do not solve the challenges associated with well operations in deep water with low temperature and production of heavy oil with high viscosity, but may  
15 be included in the solutions designed for such situations.

With the present invention is provided a sub-sea processing system in connection with the production of oil and/or gas from one or more wells, especially wells producing heavy oil in deep water and with high viscosity. The system is designed to maintain preferred production temperature and is, in particular, designed to obtain  
20 required temperature conditions under start-up and shut-in.

According to an aspect of the present invention, there is provided sub-sea processing system for the production of oil and/or gas from one or more production wells, wherein the system includes: one or more injection wells for the injection of produced water, or produced water deposit(s); a separator with an inlet and outlets for water, oil  
25 and/or gas; a water injection and circulation pump; a heating arrangement; and a flow control device, wherein a water circulation and injection pipe loop is provided to interconnect the separator, the injection and circulation pump, the heating

32137-2

2a

arrangement, the flow control device, the one or more injection wells and the one or more productions wells, whereby, prior to start-up and during production of any of the wells, the loop circulates hot water to control the temperature of the fluid flow in the loop, thereby controlling the viscosity and the water cut in the fluid flow.

- 5 The present invention will be further described in the following by way of example and with reference to the figures, where:

Fig. 1 shows a principal sketch or scheme of a processing system according to the invention,

5

Fig. 2 shows a principal sketch or scheme of an alternative processing system according to the invention.

10 Fig. 1 shows, as stated above, a principal sketch or scheme of the processing system according to the invention. The system may include one or more production wells 1 for the production of oil and/or gas, one or more injection wells 2 for the injection of produced water, a flow control device 11, a separator 3, a production pump 4, a water injection and circulation pump 5 and a heating arrangement 6. The heating arrangement  
15 may preferably be in the form of an electrical heating system however, depending on the environmental situation, e.g. the surrounding temperature, sufficient heat may be provided through the work (heat energy) generated by the circulation pump 5.

The major feature of the invention is the provision of a water circulation and injection pipe loop 7 interconnecting the separator 3, the injection and circulation pump 5, the  
20 heating arrangement 6, the flow control device 11 and the wells 1 and 2. Water is initially added to the system through a water supply line 8 and is heated by the circulation pump and, if required, by the heating arrangement 6. The heated water is circulated by the circulation pump 5 to the injection well 2, further to the flow control device 11 and the production well 1 and thereafter to the separator 3, before finally  
25 being returned from the separator to the circulation pump 5. At start-up of the production wells the heated water in the pipe loop system prevents wax and/or hydrates to deposit in the piping. Before starting production, the hot water gradually heats the well to the required start-up temperature to avoid that any wax or hydrates being present in the produced oil will be deposited in the well or production piping. Further, during start-up,  
30 produced well fluid will mix with the water in the loop and after a while, as production increases, reach steady state conditions. Thus produced fluid in the form of oil/water and possible gas flows through the production and circulation pipeline 9 to the separator 3 where the major parts of the hydrocarbons (oil and possible gas) are separated from the water. The produced oil and possible gas being present in the fluid flow is

transferred by means of the production pump 4 from the separator 3 to the desired destination 15 (a platform, production ship, trunk line, shore terminal etc.) via a production pipeline 12. Alternatively as shown in Fig. 2, the oil and gas may be transported individually from the separator in separate oil and gas pipelines 12 and 13 respectively.

The produced water on the other hand is circulated from the separator 3 by the circulation pump 5 to the injection well 2 and/or to the flow control device 11. Further, based on the amount of produced water from the wells, additional injection water may be added to the circulation system through the water supply line 8 to maintain sufficient water for injection and to maintain the desired water cut conditions to obtain the best possible separation situation in the separator 3. A multiphase detection device 14 is provided prior to the separator 3 measuring the amount of water being present in the fluid flow ahead of the separator, whereby water is added to the system through the supply line 8, the flow control device 11, or production/injection wellhead chokes adjusted accordingly based on these and other measurements.

At shut-in, when production of oil and gas is halted, circulation of water is maintained to keep the temperature at the desired level to avoid wax or hydrate deposits. If production is halted over a longer period of time, it may be appropriate to stop the circulation of water in the system. In such case, however, all of the oil in the circulation system should be evacuated and replaced by water and/or by a mixture of water and traditional inhibitors. Water or a water/inhibitor mixture should be injected into the production well to avoid depositions of wax and build up of hydrates in the upper parts of the production well being cooled down by the cold surroundings.

As indicated above any separator could be used to separate the water from the hydrocarbons in the system. However, a pipe separator may in some situations represent the desired choice due to separation performance and structural design. Thus, by using a pipe separator, the system as described above and including the separator 3, the heater 6, the pumps 4, 5 and the circulation and production piping 7, 8, 9 could easily fit within a bundle pipe arrangement which would make the system according to the invention quite compact and applicable for deep water installations.

32137-2

5

The vertical column 10 on the right hand side of the Figs. 1 and 2 indicate a riser bundle being connected to a production platform or ship etc. 15 and may include all required riser and supply lines such as the production lines 10, 13, the water supply line gas lift lines and electrical cables etc.

- 5 The scope of the claims should not be limited to the above examples and the attached figures, but should be given the broadest interpretation consistent with the description as a whole. Thus, the system does not require the use of injection well(s) to handle produced water. Instead the produced water could be handled by a disposal solution, for instance a disposal well.
- 10 The injection and production wells may be arranged as individual wells, template wells or bundle integral wells.

Further, the separator and pump station may constitute a separate modular installation or is integrated in the pipe-loop.

- 15 Still further, the water supply to the system may be supplied by means of a separate water producing well.

32137-2

6

CLAIMS:

1. Sub-sea processing system for the production of oil and/or gas from one or more production wells, wherein the system includes:

5 one or more injection wells for the injection of produced water, or produced water deposit(s);

a separator with an inlet and outlets for water, oil and/or gas;

a water injection and circulation pump;

a heating arrangement; and

a flow control device,

10 wherein a water circulation and injection pipe loop is provided to interconnect the separator, the injection and circulation pump, the heating arrangement, the flow control device, the one or more injection wells and the one or more productions wells, whereby, prior to start-up and during production of any of the wells, the loop circulates hot water to control the temperature of the fluid flow in the  
15 loop, thereby controlling the viscosity and the water cut in the fluid flow.

2. System according to claim 1, wherein the pipe loop is provided in a bundle arrangement.

3. System according to claim 1, wherein the pipe loop constitute individual flexible or rigid flow lines.

20 4. System according to any one of claims 1 to 3, wherein the injection and production wells are arranged as individual wells, template wells or bundle integral wells.

32137-2

7

5. System according to any one of claims 1 to 4, wherein the separator and pump constitute a separate modular installation or is integrated in the pipe-loop.
6. System according to claim 1, wherein a production pump is provided at the outlet end of the separator to transfer the produced oil and gas to the desired  
5 destination via a production pipeline.
7. System according to claim 1 or 2, wherein a separate gas production line is provided for the evacuation of the produced gas.
8. System according to any one of claims 1 to 7, wherein the produced water is injected into a disposal well.
- 10 9. System according to any one of claims 1 to 8, wherein water supply to the system is provided by means of a separate water producing well.
10. System according to any one of claims 1 to 9, wherein the flow control device constitutes more than one device.
11. System according to any one of claims 1 to 10, wherein the flow control  
15 device constitutes more than one separate retrieval modules.
12. System according to any one of claims 1 to 11, wherein the one or more production wells produce heavy oil with high viscosity in deep water.

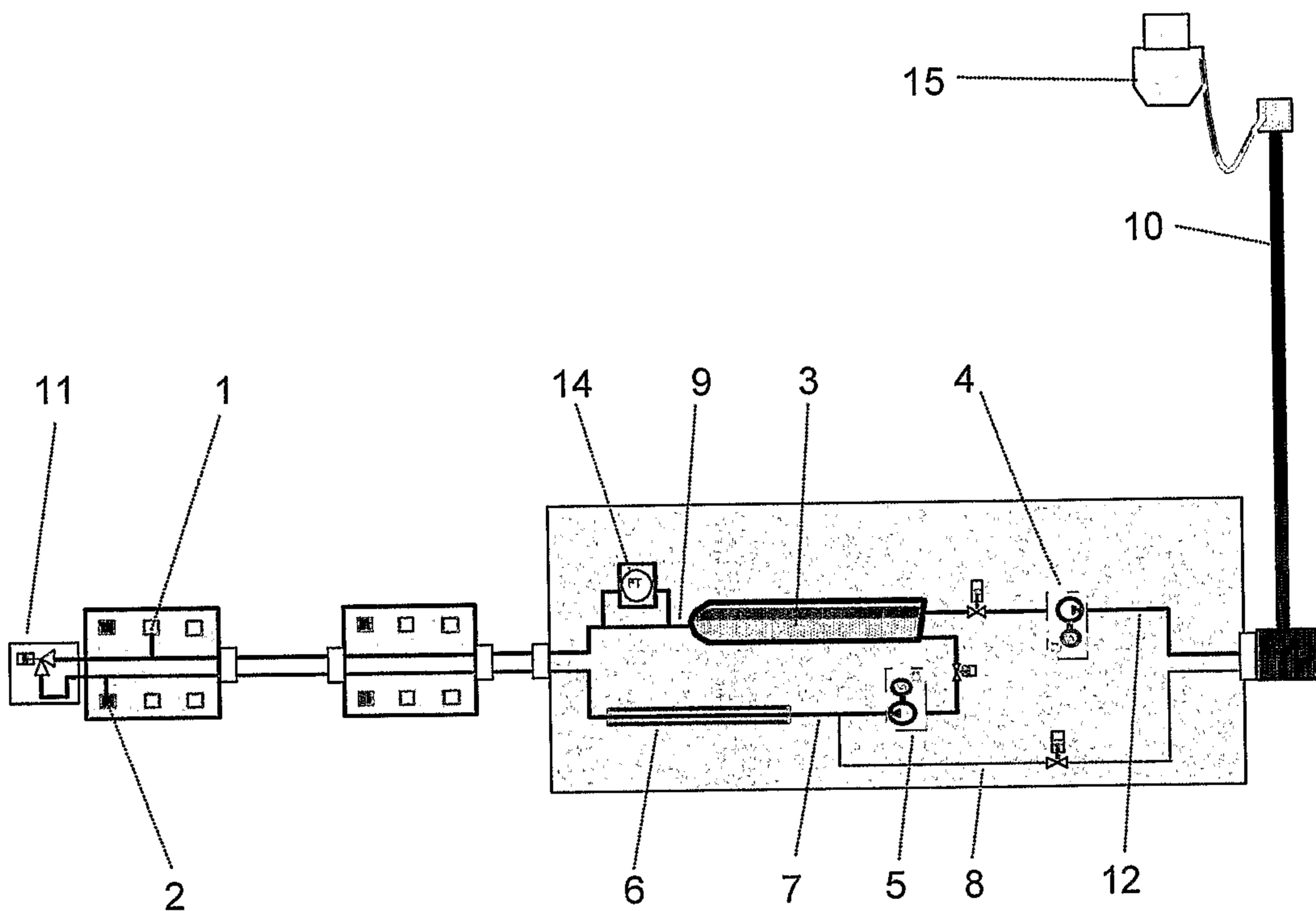

Fig. 1

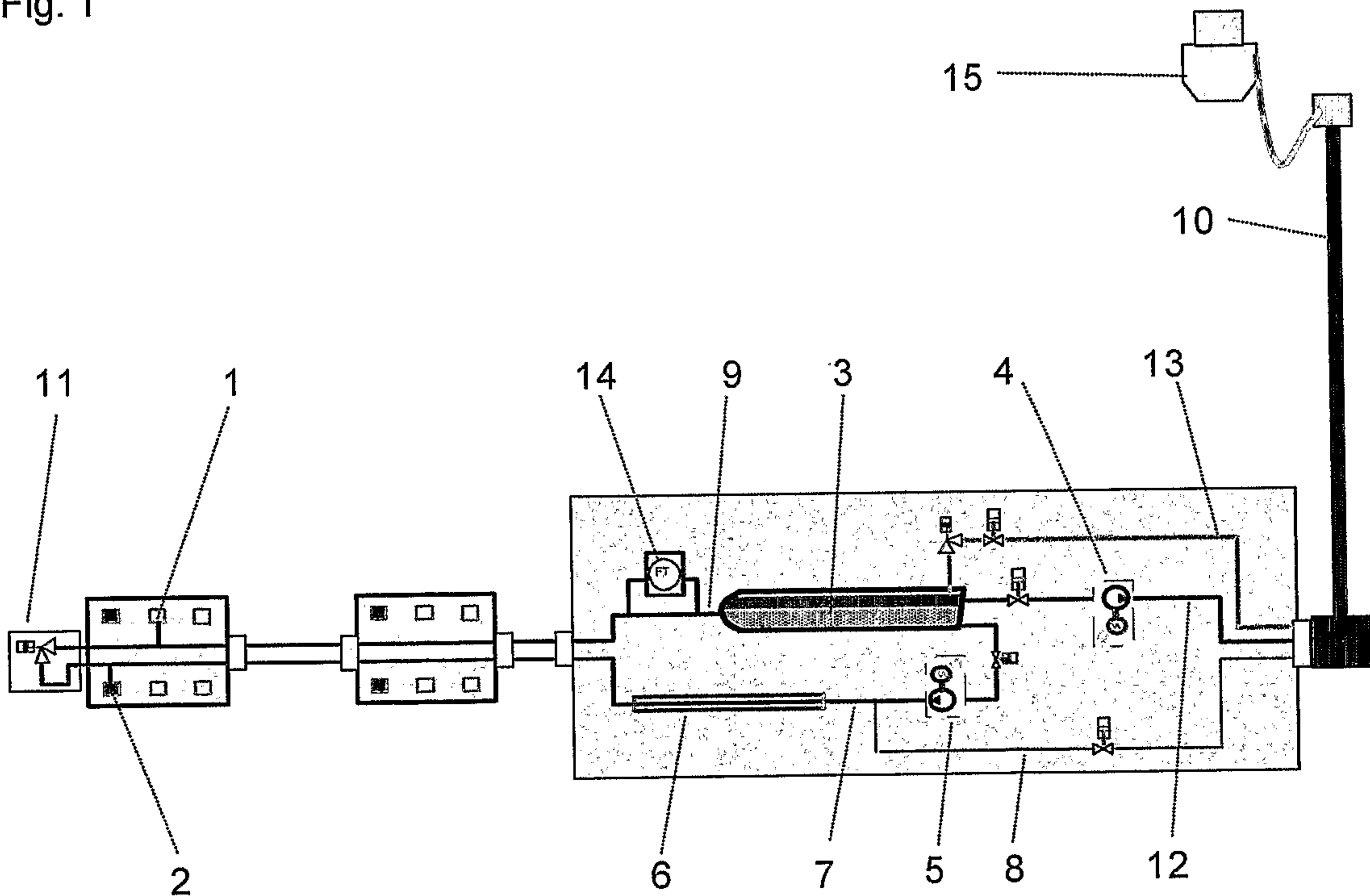

Fig. 2

