

(No Model.)

C. P. POOLE.
CONDUIT FOR ELECTRIC RAILWAYS.

No. 413,731.

Patented Oct. 29, 1889.

Fig. 1.

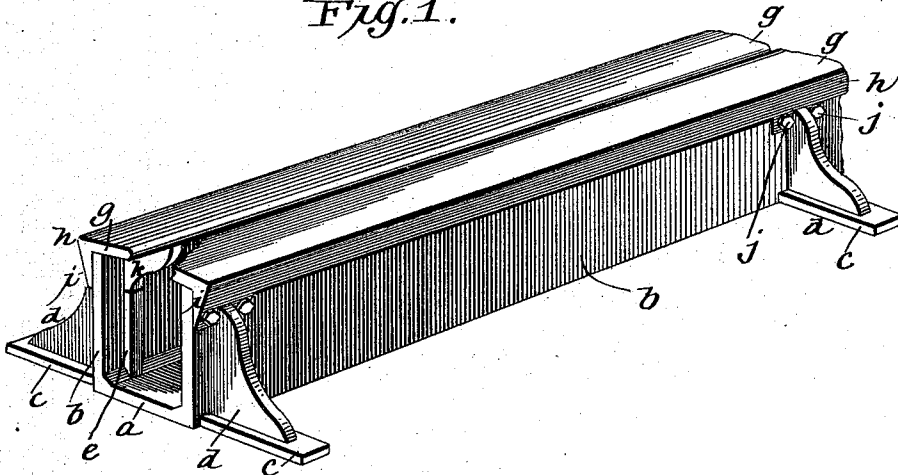
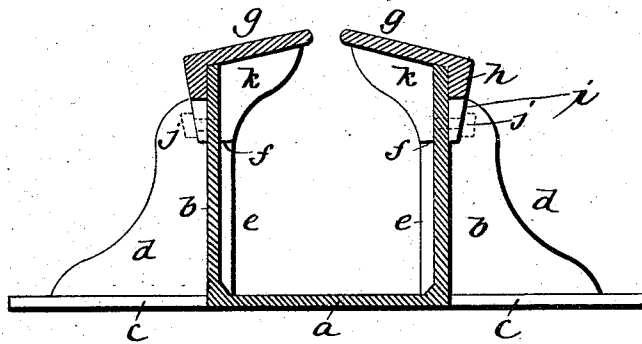

Fig. 2.



WITNESSES:

Frank A. Ober

Wm. H. Reubens

INVENTOR
Cecil P. Poole,

BY

Wm. H. Reubens
ATTORNEY

UNITED STATES PATENT OFFICE.

CECIL PERCY POOLE, OF LYNCHBURG, VIRGINIA.

CONDUIT FOR ELECTRIC RAILWAYS.

SPECIFICATION forming part of Letters Patent No. 413,731, dated October 29, 1889.

Application filed March 23, 1889. Serial No. 304,571. (No model.)

To all whom it may concern:

Be it known that I, CECIL PERCY POOLE, a citizen of the United States, residing in Lynchburg, in the county of Campbell and State of Virginia, have invented certain new and useful Improvements in Conduits for Electric Railways, of which the following is a specification.

My improved conduit consists of a rectangular metallic box or trough and a cover of similar material, both made in sections of practicable length for being produced by casting, said cover being composed of two parts, known as "slot-rails," and the box and cover comprising the novel features of construction and arrangement, which will be hereinafter described and claimed.

Further objects are cheapness of construction, strength of arrangement, and convenience in laying in the first place and for subsequent access.

Referring to the accompanying drawings, Figure 1 is a perspective view of a short section of my improved conduit, a corner of the front end of one of the slot-rails being broken off; and Fig. 2 is a transverse section of the same.

I produce the trough, of which *a* represents the bottom, and *b* the sides, with the exterior integral base-flanges *c* projecting laterally from the bottom at suitable intervals apart for bolting the conduit to the ties or other foundation on which the conduit is to be laid, each flange having a brace-web *d* extending nearly to the top of the side of the box. I also make said trough with the interior vertical stay-ribs *e* of the sides, these being in practice located at shorter intervals apart than the exterior braces, but not extending up the sides so far, and terminating in shoulders at *f*, thereby serving for the foot-rests of the braces of the slot-rails besides their function as stay-ribs for the sides of the trough. I make the slot-rails, which consist of the cover-plates *g*, with a depending flange *h* on the outer edge, reaching down the outside of the box to the top of the brace-webs *d*, or thereabout. The flange has downward projections upon each side of the brace-webs in the form of strong lips *i*, for securing the flange to the sides of the box by tap-bolts *j*. On the under side of the slot-rails I provide the

bracket-braces *k*, integral therewith and coincident with the stay-ribs *e*. They have foot-rests on the shoulders *f* of said ribs. These braces and the lips *i*, bolted to the outside of the box sides, form a simple and efficient means for sustaining the overhanging slot-rails, which are subjected to the stresses of heavy trucking over them.

The braces *k* join the slot-rails only, being separated from the flanges *h* to the extent of the thickness of the sides of the box, so that the slot-rails come to a bearing on the upper edges of the sides of the box when the foot-bearings of the braces *k* rest on the shoulders *f*'. The flanges *h* also bear on the upper ends of the brace-webs *d* between the lips *i*, thus making three different bearing-points between which the support of the slot-rails is distributed, with advantage in avoidance of undue local strains. The arrangement is such that having previously fitted the parts the slot-rails have only to be placed on the sides of the box after it has been placed in position and the tap-bolts screwed in.

The flanges *h* and lips *i* taper downward, so that when the cover is to be lifted or removed there will be no disturbance of the earth or pavement in which the flanges are packed or embedded, except where it is necessary to remove enough to permit the removal of the bolts. In other places the packed earth or pavement will remain and the cover can be replaced with only such displacements at the localities of the bolts.

With the improved construction described it has been found unnecessary to alter the thickness of the material of which the conduit is made in order to meet varying conditions of strain, as this can be provided for by having the braces and stay-ribs closer together or farther apart, according as the conduit is to be subjected to heavier or lighter traffic.

The box or trough of the conduit may have foot-rests for the bracket-braces, which do not include stay-ribs extending to the bottom of the trough, and although I prefer to arrange them so I do not mean to be limited to such arrangement. While it is better to have the flanges *h* rest on the top of the braces *d* between the lips *i* and share with the bearing of the slot-rails on the top of the box sides and with the bracket-braces on the shoulders

of the stay-ribs in the vertical support of the slot-rails, it is manifest that without such bearing the advantages of my improved conduit will be had in about the same measure, and I do not limit my claims in that respect.

Having now described my invention, I claim—

1. The combination, with the metallic box or trough, of the metallic slot-rails resting upon the upper edges of the sides and having the flanges and fastening-lips outside of and bolted to the box sides and the bracket-braces inside and supported on foot-rests upon the box sides, substantially as described.

2. The combination, with the metallic box or trough having the exterior laterally-projecting base-flanges and brace-webs, of the metallic slot-rails resting on the upper edges of the box sides and having the flanges outside of the box sides and bracket-braces inside of the box, said outside flange resting on the brace-web and having the fastening-ribs embracing the brace-webs and bolted to the sides of the box.

3. The combination, with the metallic box

or trough having the interior stay-ribs, with supporting-shoulders at the upper ends, also having the exterior laterally-projecting base-flanges and brace-webs, of the slot-rails resting on the upper edges of the box sides, having the bracket-braces inside of the box and resting on the shoulders of the stay-ribs, also having the outside flanges resting on the brace-webs and provided with downwardly-projecting lips embracing the brace-webs and bolted to the box sides, as set forth.

4. The combination, with the sides of the box or trough, of the slot-rails resting on the upper edges of the box sides and having bracket-brace supports inside of the box, also a flange and bolting-lips extending down outside of the box sides, said flange and bolting-lips being tapered, substantially as set forth.

In witness whereof I have hereunto affixed my seal and signed my name in the presence of two subscribing witnesses.

CECIL PERCY POOLE. [L. S.]

Witnesses:

W. M. LILE,
M. I. WALKER.