

(No Model.)

2 Sheets—Sheet 1.

F. H. RICHARDS.
FURNACE.

No. 510,550.

Patented Dec. 12, 1893.

Fig. 1.

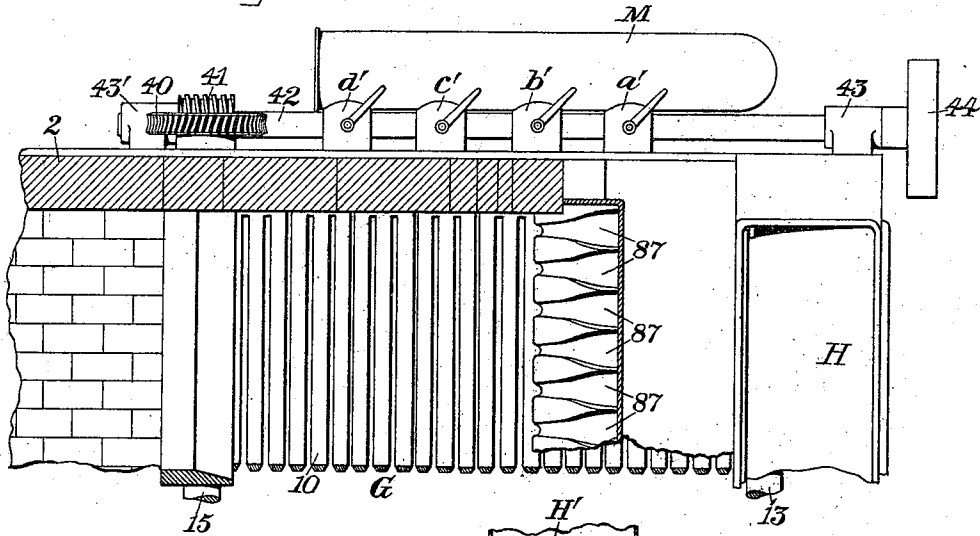
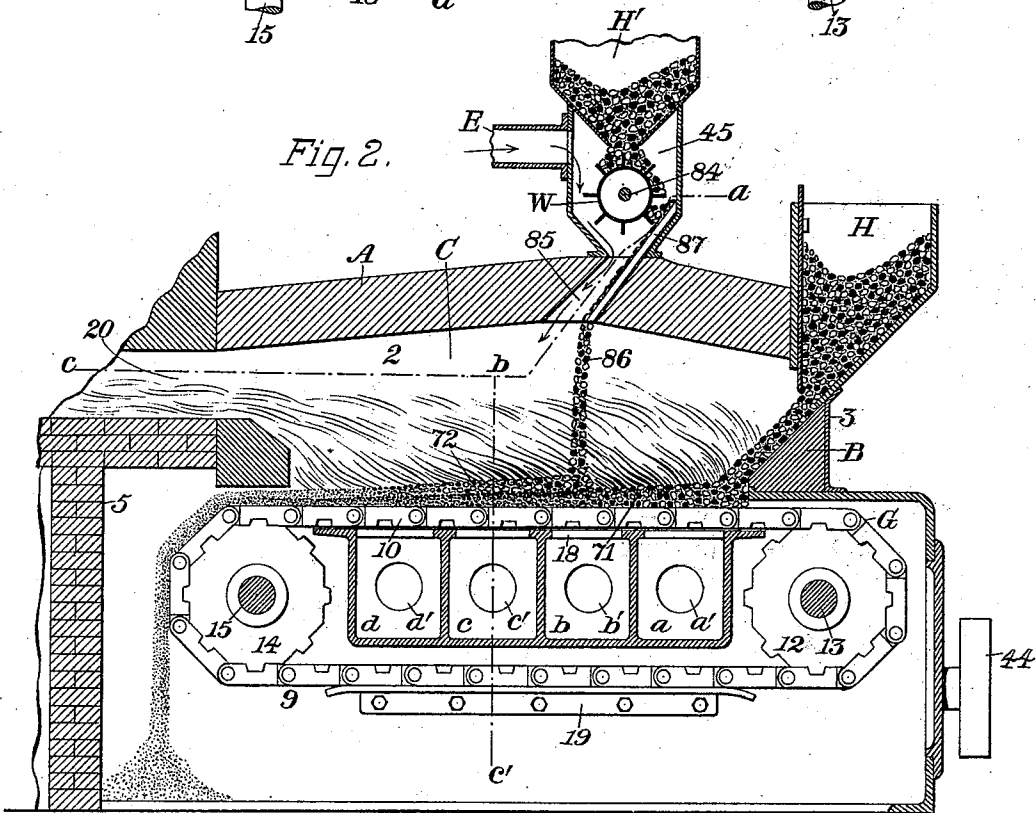

Fig. 2.



Witnesses:
John L. Edwards Jr.
Fred. J. Dole

Inventor:
F. H. Richards

F. H. RICHARDS.
FURNACE.

No. 510,550.

Patented Dec. 12, 1893.

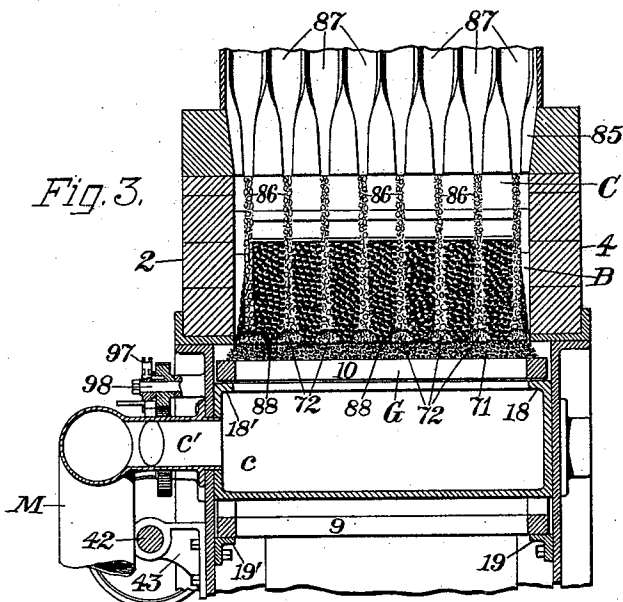
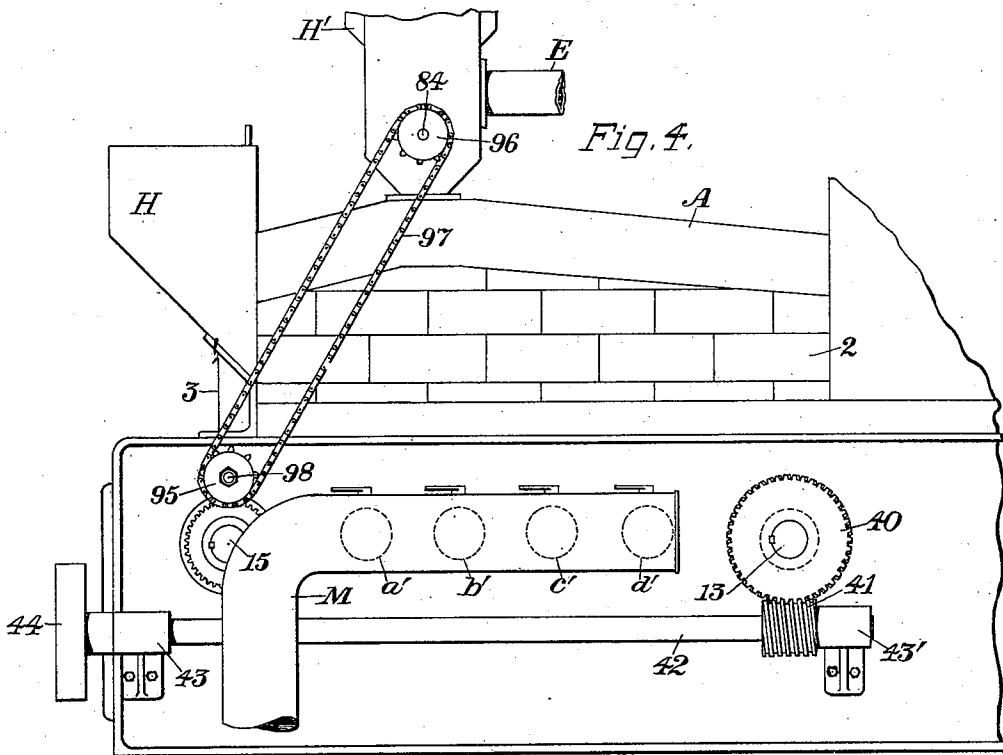

Witnesses:
John L. Edwards Jr.
Fred. J. Dole.

Inventor:
F. H. Richards

UNITED STATES PATENT OFFICE.

FRANCIS H. RICHARDS, OF HARTFORD, CONNECTICUT, ASSIGNOR TO ECKLEY
B. COXE, OF DRIFTON, PENNSYLVANIA.

FURNACE.

SPECIFICATION forming part of Letters Patent No. 510,550, dated December 12, 1893.

Application filed September 1, 1893. Serial No. 484,557. (No model.)

To all whom it may concern:

Be it known that I, FRANCIS H. RICHARDS, a citizen of the United States, residing at Hartford, in the county of Hartford and State of Connecticut, have invented certain new and useful Improvements in Furnaces, of which the following is a specification.

This invention relates to traveling-grate furnaces; the object being to provide an improved furnace of that class adapted for burning two grades of fuel at the same time.

My present invention is in a general way in the nature of an improvement on the furnace described and claimed in Letters Patent No. 499,716, granted to Eckley B. Coxe, June 20, 1893, to which reference may be had for a more particular description than is contained herein of certain details of the furnace-mechanism; it is also specifically in the nature of an improvement on the furnace described and claimed in the prior application of said Eckley B. Coxe, Serial No. 479,998, filed July 10, 1893, to which I have permission to refer.

The principal object of my present invention is to provide means for supplying the second (and usually lower) grade of fuel to the furnace in separate streams to form narrow separate layers, which shall not interfere so much with the proper combustion of the lower layer of fuel; also, to supply fresh air to the combustion-chamber, and at the same time protect the second fuel-supply apparatus from the heat of the furnace-gases.

In the drawings accompanying and forming a part of this specification, Figure 1 is a sectional plan view (on line *a b c*, Fig. 2) of a traveling grate furnace embodying my present improvements. Fig. 2 is a sectional side elevation of the furnace. Fig. 3 is a vertical transverse section on line *a b c*, Fig. 2, showing the parts at the right-hand of said line as seen from a point at the left-hand thereof. Fig. 4 is a side elevation of the furnace as seen from the right-hand in Fig. 3. In Figs. 2 and 3 the furnace is shown supplied with fuel as when in operation.

Similar characters designate like parts in all the figures.

For illustrating the application and mode of operation of my present improvements, I have shown the same applied to the furnace

which is described and claimed in the aforesaid Letters Patent No. 499,716. This furnace comprises a traveling grate and means for actuating the same, and has its furnace-chamber C, and also the grate-mechanism, inclosed by the usual side-walls 2 and 4, and end-walls 3 and 5.

The endless-grate, designated in a general way by G, comprises the lower and upper runs, 9 and 10, respectively; said upper run constituting the furnace-floor under which is located the series of air-blast chambers *a, b, c, d*, these being supplied by the air-pipes *a', b', c', d'*, through a conduit, M, leading from a blower, air-compressor or other air-supply, not shown. The upper and lower runs, respectively, of the endless grate are shown supported on guides, 18 and 18' and 19 and 19', respectively. For actuating the traveling-grate G, this is shown carried by the chain-wheels 12 and 14, which are supported on the shafts 13 and 15, respectively; and for revolving the one of the shafts and thereby actuating the grate, said shaft 15, is shown furnished with the worm-wheel 40, which meshes with a worm, 41, on a driving-shaft, 42, that is supported in bearings, 43, 43', and is driven by a driving-pulley, 44, from some suitable source of power. Not shown. These several details belonging to the invention described and claimed in the aforesaid Letters Patent, a further description of the same is deemed unnecessary.

For delivering the regular or first supply of fuel to the endless-grate, the furnace is or may be provided with the supply-hopper H, whose mouth or discharge-opening delivers the fuel directly onto the grate, over an ignition-block, B, as illustrated in Fig. 2. Immediately rearward of said supply-hopper H, the furnace-chamber C is shown covered with a roof or arch, designated by A, in which an opening is made at 85, through which to supply the grate with an additional quantity of fuel, usually of another and lower grade. From the furnace-chamber C, the gases may be conducted through the flue 20 to be used. As a means for regularly delivering the additional fuel-supply to the furnace-chamber through the aforesaid opening 85, a feed-apparatus is shown set over said opening, and

comprises a hopper, H', suitably supported, and a feed-wheel or bucket-wheel, W, set underneath said hopper in position for receiving the fuel therefrom and delivering the same in a falling stream, 86, into the furnace-chamber, as fully illustrated in Fig. 2. For actuating said feed-wheel, the shaft 84 of said wheel is shown furnished with a pulley or chain-wheel, 96, which is connected by a driving band or chain, 97, with a chain-wheel, 95, carried on a stud, 98, and geared with the shaft 15. By making the wheels 95 and 96 of proper relative dimensions, any required speed may be imparted to said feed-wheel, for delivering to the furnace any required proportion of the secondary fuel.

The operation of the furnace, except as to the secondary fuel-supply, is substantially the same as illustrated and described in the aforesaid Letters Patent No. 499,716. The fuel in the hopper H is delivered directly to the grate, on which it is spread in a layer, and during the regular operation of the furnace is ignited at a point adjacent to or over the first air-blast chamber *a*, which chamber is, in practice, supplied with air at a moderate pressure. The air-blast chamber *b* is ordinarily supplied with air at a considerably higher pressure, for the purpose of increasing the combustion and raising the burning mass to a high temperature. During or immediately following the thorough ignition of the layer 71, of fuel, the secondary supply of fuel is delivered to the furnace-chamber, being deposited in a series of separated layers, 72, superimposed upon said lower layer 71. In practice, said secondary supply is intended to be of a relatively low grade, such, for instance, as carbonaceous slates and minerals found in connection with veins of pure coal. The secondary fuel being delivered into the hot furnace-chamber upon a bed of fuel already brought to a high state of combustion, the carbon is rapidly distilled therefrom and mingled with the furnace-gases, to be consumed in the rearward portions of the furnace-chamber; the refuse mineral being finally carried off with the ashes and cinder from the higher grade of fuel forming the first layer upon the furnace-floor.

It will be remembered that in the furnace herein shown, when operated as described in the aforesaid Patent, No. 499,716, the air-pressures in the chambers *c* and *d* will (usually) be normally less than in the air-blast chamber *b*; but in the present instance, owing to the increased quantity of fuel beyond the point where the secondary supply is delivered to the grate, the air-pressure will, in some cases, be somewhat increased in one or more of said chambers, for forcing the combustion of the combined primary and secondary layers of fuel. In this connection it will be understood that the number and width of the successive air-blast chambers will be regulated according to the duty required of the furnace.

According to my present improvements, the

passage-way 85 in the furnace-roof through which the second fuel-supply is delivered to the furnace-chamber C is set inclined, preferably as shown in Fig. 2, and the upper surface at the forward side of said opening is furnished with a series of guides, 87, which, when the fuel is delivered upon them, as from the feed-wheel W, as illustrated in Fig. 2, divide it into separate streams, 86, Fig. 3, which, by passing down said guides are separated and, descending upon the lower layer 71 of fuel upon the traveling grate, form a series of narrow layers 72 separated from each other so as not to interfere so much with the combustion of said lower and principal layer received by the grate from the first fuel-supply apparatus, which, in the present instance, is the aforesaid hopper H.

By delivering the second fuel-supply to the grate in relatively narrow layers, spaces, 88, between said layers are provided for the escape of the gases from the lower layer. By this means the combustion of the lower layer may be more rapid, and the second fuel-supply is subjected at the edges of said narrow layers 72 to the action of the flames within the furnace-chamber, and is thereby more effectively decarbonized, and the carbon thereof better utilized. For preventing the furnace-gases from ascending through said roof-space 85, and to prevent the same from burning out and destroying the second fuel-supply apparatus, also to furnish a moderate supply of fresh-air to mingle with the gases of the furnace-chamber and thereby promote the combustion of the same, the chamber 45 of said fuel-supply apparatus H' is closed, and is supplied with an air-blast through some suitable pipe, as E, attached thereto. Said supplemental air-supply being delivered through said pipe E to said closed chamber 45, passes at the side of said feed-wheel W and downwardly through said roof passage-way, as indicated by the arrows, carrying with it any furnace-gases which may have descended into said passage-way. By this means, all of the objects here specified are readily attained, and the supplemental supply of air is delivered to the furnace-chamber in a manner and at the point for securing the most effective combustion, especially when using for the first fuel-supply a fuel of a bituminous or semi-bituminous character.

Having thus described my invention, I claim—

1. In a furnace, the combination with the furnace-chamber and its roof having an opening therein, of a traveling grate and a fuel-supply therefor, means for supplying air to the grate, a second fuel-supply in position for delivering fuel to the grate through said roof-opening at a point beyond the normal ignition-line of the fuel first supplied, and fuel-guides set to divide the second fuel-supply into separated layers, substantially as and for the purpose set forth.

2. In a furnace, the combination with the

furnace-chamber and its roof having an opening therein, of a traveling grate—and a fuel supply therefor, a second fuel supply in position for delivering fuel to the grate through the roof-opening and comprising a chamber covering said opening, and an air-supply for said chamber, whereby a supply of fresh air may be delivered to the furnace-chamber through said opening, substantially as described and for the purpose specified.

3. In a furnace, the combination with the furnace-chamber and its roof having an opening therein, and with a traveling-grate and the

first fuel-supply therefor, of the second fuel-supply located above said roof opening and comprising a chamber covering said opening, a feed-wheel within said chamber for delivering the second supply of fuel to the furnace, means for actuating the feed-wheel and the traveling-grate, and an air-supply for said chamber, substantially as described.

FRANCIS H. RICHARDS.

Witnesses:

FRED. J. DOLE,
JOHN L. EDWARDS, Jr.