



- (51) International Patent Classification:  
G01S 13/00 (2006.01)
- (21) International Application Number:  
PCT/IB2018/050819
- (22) International Filing Date:  
09 February 2018 (09.02.2018)
- (25) Filing Language: English
- (26) Publication Language: English
- (30) Priority Data:  
62/457,394 10 February 2017 (10.02.2017) US
- (71) Applicant: UHNDER, INC. [US/US]; 3409 Executive Center Dr., Suite 205, Austin, Texas 78731 (US).
- (72) Inventors: MAHER, Monier; 7744 Mohawk Pl., St. Louis, Missouri 63105 (US). DAVIS, Curtis; 1734 Fron-

tenac Woods Lane, St. Louis, Missouri 63141 (US). RUSH, Frederick; 3600 Greystone Dr., Apt. 714, Austin, Texas 78731 (US). ESHRAGHI, Aria; 1709 Acacia Bud Dr., Austin, Texas 78733 (US).

(74) Agent: LEHMAN, Jeffrey; 2851 Charlevoix Dr., SE, Suite 207, Grand Rapids, Michigan 49546 (US).

(81) Designated States (unless otherwise indicated, for every kind of national protection available): AE, AG, AL, AM, AO, AT, AU, AZ, BA, BB, BG, BH, BN, BR, BW, BY, BZ, CA, CH, CL, CN, CO, CR, CU, CZ, DE, DJ, DK, DM, DO, DZ, EC, EE, EG, ES, FI, GB, GD, GE, GH, GM, GT, HN, HR, HU, ID, IL, IN, IR, IS, JO, JP, KE, KG, KH, KN, KP, KR, KW, KZ, LA, LC, LK, LR, LS, LU, LY, MA, MD, ME, MG, MK, MN, MW, MX, MY, MZ, NA, NG, NI, NO, NZ, OM, PA, PE, PG, PH, PL, PT, QA, RO, RS, RU, RW, SA,

(54) Title: RADAR DATA BUFFERING

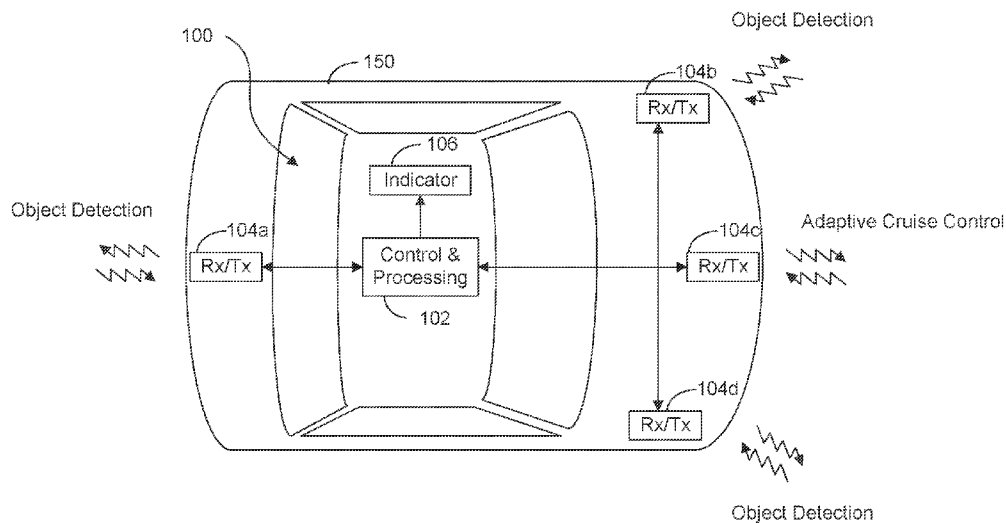

FIG. 1

(57) Abstract: A radar system includes transmitters and receivers configured for installation and use in a vehicle. The transmitters transmit radio signals. The receivers receive radio signals that include the transmitted radio signals reflected from objects in an environment. Each receiver has an RF front end, an analog-to-digital converter (ADC), a digital signal processor, and a controller. The digital signal processor processes the data from the ADC and stores data samples in a buffer. The buffer operates in several modes defined by the controller. These modes include replay mode, loopback mode, quiet mode and throttle mode. By controlling the buffer, the same received samples can be processed in multiple ways to generate information on targets at different ranges and velocities. The buffer is read out and the data is processed further to enable the radar system to determine range, velocity and angle of targets in the environment.



SC, SD, SE, SG, SK, SL, SM, ST, SV, SY, TH, TJ, TM, TN,  
TR, TT, TZ, UA, UG, US, UZ, VC, VN, ZA, ZM, ZW.

- (84) Designated States** (*unless otherwise indicated, for every kind of regional protection available*): ARIPO (BW, GH, GM, KE, LR, LS, MW, MZ, NA, RW, SD, SL, ST, SZ, TZ, UG, ZM, ZW), Eurasian (AM, AZ, BY, KG, KZ, RU, TJ, TM), European (AL, AT, BE, BG, CH, CY, CZ, DE, DK, EE, ES, FI, FR, GB, GR, HR, HU, IE, IS, IT, LT, LU, LV, MC, MK, MT, NL, NO, PL, PT, RO, RS, SE, SI, SK, SM, TR), OAPI (BF, BJ, CF, CG, CI, CM, GA, GN, GQ, GW, KM, ML, MR, NE, SN, TD, TG).

**Published:**

- *with international search report (Art. 21(3))*
- *in black and white; the international application as filed contained color or greyscale and is available for download from PATENTSCOPE*

## RADAR DATA BUFFERING

### CROSS REFERENCE TO RELATED APPLICATIONS

**[0001]** The present application claims the filing benefits of U.S. provisional application, Ser. No. 62/457,394, filed Feb. 10, 2017, which is hereby incorporated by reference herein in its entirety.

### FIELD OF THE INVENTION

**[0002]** The present invention is directed to radar systems, and in particular to radar systems for vehicles.

### BACKGROUND OF THE INVENTION

**[0003]** The use of radar to determine range, velocity, and angle (elevation or azimuth) of objects in an environment is important in a number of applications including automotive radar and gesture detection. Radar typically transmits a radio frequency (RF) signal and listens for the reflection of the radio signal from objects in the environment. A radar system estimates the location of objects, also called targets, in an environment by correlating delayed versions of the received radio signal with the transmitted radio signal. A radar system can also estimate the velocity of the target by Doppler processing. A radar system with multiple transmitters and multiple receivers can also determine the angular position of a target.

**[0004]** A radar system consists of transmitters and receivers. The transmitters generate a baseband signal which is up-converted to a radio frequency (RF) signal that propagates according to an antenna pattern. The transmitted signal is reflected off of objects or targets in the environment. The received signal at each receiver is the totality of the reflected signal from all targets in the environment. The receiver down converts the received signal to baseband and compares the baseband received signal to the baseband signal at one or more transmitters. This is used to determine the range, velocity and angle of targets in the environment.

## SUMMARY OF THE INVENTION

**[0005]** The present invention provides methods and a system for achieving better performance in a radar system implemented as a modulated continuous wave radar. An exemplary radar system of the present invention is a radar system for a vehicle that includes multiple transmitters and receivers, implemented as a multiple-input, multiple-output (MIMO) radar system. Each exemplary receiver of the radar system comprises a receive front end, an analog-to-digital converter (ADC), a pre-buffer signal processing unit to process samples from the ADC, and a buffer configured to hold data samples for processing by a post-buffer signal processor. An exemplary buffer is configured to selectively operate in one of several possible processing modes, such as a replay mode, a loopback mode, a quiet mode, and throttle modes. These selectable modes for the buffer provide for an improved operation of the receiver in detecting objects in an environment by allowing the receivers to process the data samples in a variety of ways. In an aspect of the invention, a same set of stored data samples may be processed a number of different ways.

**[0006]** A radar sensing system for a vehicle in accordance with an embodiment of the present invention includes a plurality of transmitters and a plurality of receivers. The transmitters are configured for installation and use on a vehicle and configured to transmit radio signals. The receivers are configured for installation and use on the vehicle and are configured to receive radio signals which include transmitted radio signals transmitted by the transmitters and reflected from objects in an environment. Each receiver includes an antenna, a radio frequency front end, an analog-to-digital converter (ADC), and a controller. The receiver is structured as a pipeline where one subsystem processes input data and generate output data processed by another subsystem. Part of the pipeline includes a pre-buffer processor that processes the data from the ADC. Another part of the pipeline is a buffer which stores the data samples related to the output of the analog-to-digital converter. The buffer can operate in several modes, as defined by the controller. These modes include replay mode, loopback mode, quiet mode, and throttle mode. The buffer can also feed information back to the pre-buffer processor.

**[0007]** A radar sensing system for a vehicle in accordance with an embodiment of the present invention includes a plurality of transmitters, a plurality of receivers, and a controller. The plurality of transmitters are configured for installation and use on a vehicle and configured to transmit radio signals. The plurality of receivers are configured for installation and use on the vehicle and configured to receive radio signals that include the transmitted radio signals transmitted by the transmitters and reflected from objects in an environment. The controller is configured to control the transmitters and the receivers. Each receiver comprises (i) a radio frequency (RF) front end configured to process the received radio signals to output processed radio signals; (ii) an analog-to-digital converter (ADC) configured to receive the processed radio signals and output data samples related to the processed radio signals; (iii) a pre-buffer signal processing unit configured to perform correlations; (iv) a buffer configured to store the data samples output by the ADC; and (v) a post-buffer processor configured to receive data samples output from the buffer. The buffer is configured to operate in one of several modes, as defined by the controller. The buffer is further configured to selectively output the stored data samples, as defined by the controller. The post-buffer processor is configured to perform at least one of range processing, velocity processing, and angular processing on the stored data samples, as defined by the controller.

**[0008]** A method for controlling a radar sensing system for a vehicle in accordance with an embodiment of the present invention includes providing a radar system that includes a plurality of transmitters configured for installation and use on a vehicle and a plurality of receivers configured for installation and use on the vehicle. The method includes transmitting, with the transmitters, radio signals, and receiving, with the receivers, radio signals that include the transmitted radio signals transmitted by the transmitters and reflected from objects in an environment. The method further includes processing, with a radio frequency (RF) front end of a first receiver of the plurality of receivers, the received radio signals and outputting processed radio signals. Processing the radio signals with an analog-to-digital converter (ADC) and outputting data samples. Processing the ADC samples with a first signal processor. The processed ADC samples are stored in a buffer of the first receiver. One of several operational modes are selected for the buffer, and stored data samples are outputted as defined by the

selected operational mode. Performing, with a post-buffer processor of the first receiver, at least one of range processing, velocity processing, and angular processing on the stored data samples.

**[0009]** In an aspect of the present invention, the buffer replays the same sequence of samples a plurality of times, such that the same data samples are processed a number of different ways.

**[0010]** In an aspect of the present invention, a post-buffer processing unit is put into a sleep mode while a pre-buffer processor is actively storing data samples into the buffer.

**[0011]** In a further aspect of the present invention, post-buffer processing includes a method for selectively scaling the amplitudes of the data samples. The scaling comprises setting the values of one or more data samples to a value of zero.

**[0012]** In yet another aspect of the present invention, the data stored in the buffer is used for calibrating at least one of a radio frequency portion and a digital processing portion of the RF front end.

**[0013]** In another aspect of the present invention, a cyclic redundancy check (CDC) is evaluated on data subsequent to post-buffer processing.

**[0014]** These and other objects, advantages, purposes and features of the present invention will become apparent upon review of the following specification in conjunction with the drawings.

#### BRIEF DESCRIPTION OF THE DRAWINGS

**[0015]** FIG. 1 is a plan view of an automobile equipped with a radar system in accordance with the present invention;

**[0016]** FIG. 2A and FIG. 2B are block diagrams of radar systems in accordance with the present invention;

**[0017]** FIG. 3 is a block diagram illustrating a radar system with a plurality of receivers and a plurality of transmitters in accordance with the present invention;

**[0018]** FIG. 4 is a block diagram of a receive pipeline and transmit pipeline of a radar system in accordance with the present invention; and

**[0019]** FIG. 5 is a block diagram of a digital processing section of the receive pipeline of FIG. 4 in accordance with the present invention.

#### DESCRIPTION OF THE PREFERRED EMBODIMENTS

**[0020]** The present invention will now be described with reference to the accompanying figures, wherein numbered elements in the following written description correspond to like-numbered elements in the figures. Methods and systems of the present invention may achieve better performance from an exemplary radar system by allowing data collected by the radar system to be processed in multiple ways. For example, targets may be detected in multiple sets of ranges (e.g., 0-40 meters and 100-300 meters) by processing the data multiple ways. Multiple processing may also be used to remove additional interference. The use of multiple processing allows for a more accurate determination of velocity information by providing multiple Doppler shifts to the stored data before estimating the Doppler shift of different targets.

**[0021]** FIG 1. Illustrates an exemplary radar system 100 configured for use in a vehicle 150. In an aspect of the present invention, a vehicle 150 may be an automobile, truck, or bus, etc. The radar system 100 may utilize multiple radar systems (e.g., 104a-104d) embedded into an automobile as illustrated in FIG. 1. Each of these radar systems may employ multiple transmitters, receivers, and antennas (see FIG. 3). These signals are reflected from objects (also known as targets) in the environment and received by one or more receivers of the radar system. A transmitter-receiver pair is called a virtual radar (or sometimes a virtual receiver). As illustrated in FIG. 1, the radar system 100 may comprise one or more transmitters and one or more receivers 104a-104d for a plurality of virtual radars. Other configurations are also possible. FIG. 1 illustrates the receivers/transmitters 104a-104d placed to acquire and provide data for object detection and adaptive cruise control. As illustrated in FIG. 1, a controller 102 receives and the

analyzes position information received from the receivers 104a-104d and forwards processed information (e.g., position information) to, for example, an indicator 106 or other similar devices, as well as to other automotive systems. The radar system 100 (providing such object detection and adaptive cruise control or the like) may be part of an Advanced Driver Assistance System (ADAS) for the automobile 150.

**[0022]** An exemplary radar system operates by transmitting one or more signals from one or more transmitters and then listening for reflections of those signals from objects in the environment by one or more receivers. By comparing the transmitted signals and the received signals, estimates of the range, velocity, and angle (azimuth and/or elevation) of the objects can be estimated.

**[0023]** There are several ways to implement a radar system. One way, illustrated in FIG. 2A uses a single antenna 202 for both transmitting and receiving radio signals. The antenna 202 is connected to a duplexer 204 that routes the appropriate signal from the antenna 202 to the receiver 208 or routes the signal from the transmitter 206 to the antenna 202. A control processor 210 controls the operation of the transmitter 206 and the receiver 208 and estimates the range and velocity of objects in the environment. A second way to implement a radar system is illustrated in FIG. 2B. In this system, there are separate antennas for transmitting (202A) and receiving (202B). A control processor 210 performs the same basic functions as in FIG. 2A. In each case, there may be a display 212 to visualize the location of objects in the environment.

**[0024]** A radar system with multiple antennas, transmitters and receivers is illustrated in FIG. 3. Using multiple antennas 302, 304 allows an exemplary radar system 300 to determine an angle (azimuth or elevation or both) of targets in the environment. Depending on the geometry of the antenna system, different angles (e.g., azimuth or elevation) can be determined.

**[0025]** The radar system 300 may be connected to a network via an Ethernet connection or other types of network connections 314, such as, for example, CAN-FD and FlexRay. The radar system 300 will have memory (310, 312) to store software and data used for processing the radio signals in order to determine range, velocity, and

location of objects. Memory 310, 312 may also be used to store information about targets in the environment. There may also be processing capability contained in the ASIC 208 apart from the transmitters 203 and receivers 204.

**[0026]** An exemplary radar system includes  $N_T$  transmitters and  $N_R$  receivers for  $N_T \times N_R$  virtual radars, one for each transmitter-receiver pair. For example, a radar system with eight transmitters and eight receivers will have 64 pairs or 64 virtual radars (with 64 virtual receivers). When three transmitters (Tx1, Tx2, Tx3) generate signals that are being received by three receivers (Rx1, Rx2, Rx3), each of the receivers is receiving the transmission from each of the transmitters reflected by objects in the environment. Each receiver can attempt to determine the range and Doppler of objects by correlating with delayed replicas of the signal from each of the transmitters. The physical receivers may then be “divided” into three separate virtual receivers, each virtual receiver correlating with delay replicas of one of the transmitted signals.

**[0027]** There are several different types of signals that transmitters in different types of radar systems employ. A radar system may transmit a pulsed signal or a continuous signal. In a pulsed radar system, a signal is transmitted for a short time during a first time period and then no signal is transmitted for a short time during a subsequent second time period. This is repeated over and over. When the signal is not being transmitted, the receiver listens for echoes or reflections from objects in the environment. Often a single antenna is used for both the transmitter and receiver. The radar transmits on the antenna and then listens to the received signal on the same antenna. This process is then repeated. In a continuous wave radar system, the signal is continuously transmitted. There may be an antenna for transmitting and a separate antenna for receiving. Another classification of radar systems is the modulation of the signal being transmitted. One type of modulation is frequency modulation (FM) while another type of modulation is phase modulation (PM). In a frequency modulated continuous wave (FMCW) radar system the transmitted signals are sinusoidal signals with varying frequency. By measuring the time difference between when a certain frequency was transmitted and when the received signal contained that frequency was received, the range to an object can be determined. By measuring several different

time differences between a transmitted signal and a received signal, velocity information can be obtained.

**[0028]** A second type of continuous wave signal used in radar systems is a phase modulated continuous wave (PMCW) signal. In this type of radar system, the transmitted signal from a single transmitter is a sinusoidal signal in which the phase of the sinusoidal signal varies according to a certain pattern or code, sometimes called a spreading code, and is known at the PMCW radar receiver. The transmitted signal is phase modulated by mixing a baseband signal (e.g., with two values +1 and -1) with a local oscillator to generate a transmitted signal with a phase that is changing corresponding to the baseband signal. Typically, the phase during a given time period (called a chip period or chip duration) is one of a finite number of possible phases. A spreading code consisting of a sequence of chips, (e.g., +1, +1, -1, +1, -1, . . .) that is mapped (e.g., +1 → 0, -1 →  $\pi$ ) into a sequence of phases (e.g., 0, 0,  $\pi$ , 0,  $\pi$ , . . .) is used to modulate a carrier to generate the radio frequency (RF) signal. The spreading code could be a periodic sequence or could be a pseudo-random sequence with a very large period so it appears to be a nearly random sequence. The spreading code could be a binary code (e.g., +1 or -1). The resulting signal has a bandwidth that is proportional to the rate at which the phases change, called the chip rate  $R_c$ , which is the inverse of the chip duration  $T_c = 1/R_c$ . By comparing the return signal to the transmitted signal the receiver can determine the range and the velocity of reflected objects.

**[0029]** In some radar systems the signal (e.g. a PMCW signal) is transmitted over a short time period (e.g. 1 microsecond) and then turned off for a similar time period. The receiver is only turned on during the time period where the transmitter is turned off. In this approach, reflections of the transmitted signal from very close targets will not be completely available because the receiver is not active during a large fraction of the time when the reflected signals are being received. This is called pulse mode.

**[0030]** The radar sensing system of the present invention may utilize aspects of the radar systems described in U.S. Pat. Nos. 9,846,228; 9,806,914; 9,791,564; 9,791,551; 9,772,397; 9,753,121; 9,599,702; 9,575,160 and/or 9,689,967, and/or U.S. Publication

Nos. US-2017-0309997; US-2017-0307728 and/or US-2017-0310758, and/or U.S. patent applications, Ser. No. 15/496,038, filed Apr. 25, 2017, Ser. No. 15/689,273, filed Aug. 29, 2017, and/or Ser. No. 15/705,627, filed Sep. 15, 2017, and/or U.S. provisional applications, Ser. No. 62/486,732, filed Apr. 18, 2017, Ser. No. 62/528,789, filed Jul. 5, 2017, Ser. No. 62/573,880, filed Oct. 18, 2017, Ser. No. 62/598,563, filed Dec. 14, 2017, and/or Ser. No. 62/623,092, filed Jan. 29, 2018, which are all hereby incorporated by reference herein in their entireties.

**[0031]** An exemplary transmitter 400 and receiver 450 of a radar system is illustrated in FIG. 4. The transmitter 400 has a digital processor 410 that generates a baseband transmitted signal. The baseband signal is converted to an analog signal by a digital-to-analog converter (DAC) 420 and then mixed up to a carrier frequency and amplified by a radio frequency (RF) front end 430 before being radiated by an antenna 440. Each receiver 450 of the radar system generally will have a receive antenna 460, an analog RF front end 470, followed by an analog-to-digital converter (ADC) 480 that outputs complex valued digitized samples (i.e., values comprising a mathematical real component and a mathematical imaginary component), and then a digital baseband processing section 490.

**[0032]** As illustrated in FIG. 4, the digital baseband processing section 490 of the receiver 450 will process samples from the ADC 480. This processing includes calculating correlations with different delays of the baseband signal for each of the possible transmitted baseband signals. There are a variety of ways that the correlation process can be accomplished, including matched filter and Fourier transform processing methods. This processing to calculate correlations can be done for a set of distances. Each delay of the baseband signal corresponds to a range for a target. A range bin is a range corresponding to a certain delay of the baseband signal used in a correlation. A correlation with a particular delay is an indication of whether or not a target is present at that particular range. For example, a spreading code might have a chip rate of  $R_c = 500$  Mchips/second which would correspond to a chip duration of  $T_c = 2$  nanoseconds. An exemplary receiver might perform correlation delays at intervals of 2 nanoseconds, starting with a delay of 2 nanoseconds up to a maximum delay of 256 nanoseconds.

That is, 128 different correlations would be performed. A target at a distance of 30 meters would produce a delay of 200 nanoseconds. A correlation with the baseband spreading code at a delay of 100 chips (200 nanoseconds) would produce a large magnitude output because the reflected signal off of the target at 30 meters would produce a large correlation when the baseband spreading signal is delayed by 200 nanoseconds. A target at a distance of 30.3 meters would produce a large correlation with a baseband signal delayed by 101 chips (202 nanoseconds). Targets at a distance close to 30 meters (e.g. within  $\pm 0.15$  meters) would produce larger outputs when correlated with a baseband signal delayed by 100 chips than when correlated with a baseband signal delayed by either 99 chips or 101 chips. The exemplary range bin corresponding to 30 meters would be of width 0.3 meters. An exemplary correlation unit might therefore be set up to produce a selected set of correlations (e.g. 128 correlations for range bins starting at 0.3 meters to a distance of 38.4 meters). In other words, as illustrated in FIG. 5, a correlation processing unit 532 may be configured to produce a selected quantity of correlations or to determine the presence of targets in a selected set of range bins. Furthermore, an exemplary correlation processing unit 532 could be configured to consider different sets of range bins to perform correlations over, such that the correlation unit 532 performs multiple correlations, each correlation performed over a selected set of range bins from the sets of range bins. As discussed herein, several different correlations may also be performed on a same set of data samples.

**[0033]** As illustrated in FIG. 5, an exemplary Doppler processing unit 534, part of the post-buffer processing unit 530, may be configured to determine a velocity of a target in a range bin by processing multiple correlation outputs up to a certain maximum Doppler shift, known as the maximum unambiguous Doppler or maximum unambiguous velocity. However, if some pre-processing is performed prior to the Doppler processing (e.g. by pre-rotating the samples), then a different set of possible velocities can be estimated.

**[0034]** As discussed herein, a receiver's correlation processing unit 532 may have a limitation on the quantity and or selection of range bins that can be processed. Similarly, the receiver's Doppler processing unit 534 may have a limitation on quantity and/or range of target velocities that can be estimated.

**[0035]** As illustrated in FIG. 5, an exemplary digital baseband processing section 490 is divided into three sections (510, 520, and 530). The first section is a pre-buffer processor 510 and processes the output of the ADC (480) in order to remove interference from other radars and possibly to change the sample rate of the ADC output. The second section is a buffer 520 configured to store data samples. The data buffer 520 is described in detail below. The last section is a post-buffer processor 530, which is configured to perform correlation processing to determine the ranges of targets, Doppler processing to determine the velocity of the targets, and then, in combination with other receivers, is further configured to determine angular locations of the targets.

**[0036]** Configured to store complex samples, an exemplary buffer 520 provides intermediate storage for incoming received signals as well as PRN TX sequences. This intermediate storage can be used in various modes, such as throttle, loopback, replay, and bypass, which are described in detail below. The buffer 520 may be configured as an intermediate memory and preferably stores 16,384 chips. Because the exemplary buffer 520 simultaneously supports a write operation as well as a read operation, the buffer 520 is configured to utilize two memories in a ping-pong fashion. Each memory of the buffer 520 preferably stores a data sample representing the 16,384 chips. In each memory location of the buffer 520, a complex sample may be stored from the pre-buffer processor 510, with the real and imaginary parts each represented using 11 bits for each of the receivers. In addition, the buffer 520 stores the spreading code for each of the possible transmitted signals (e.g. 12 bits for each chip corresponding to the 12 different transmitted signals). Therefore, the total number of bits stored is preferably  $2 \times 16,384 \times (11 \times 2 \times 8 + 12)$  bits = 770,048 bytes = 752 Kbytes for the ping-pong style memory (1Kbyte=1024 bytes). The first factor of 2 is for the ping-pong memory. As discussed herein, there are 16,384 chips. Each chip requires the storing of I and Q samples of 11 bits each for each of the 8 receivers. Additionally, for each chip, 12 spreading code values are needed for the 12 different transmitters in order to perform the correlations.

**[0037]** The samples stored in the buffer 520 may be processed in various fashions or techniques. Different processing techniques may be configured to yield different range

bins over which a correlation is to be calculated. Different processing techniques may also be used to produce different Doppler frequencies used to estimate the velocity of targets in the environment. It may also be advantageous to store these processed outputs rather than merely processing the samples and then discarding the samples (processed outputs) after the processing is complete.

**[0038]** In an aspect of the present invention, a variety of selectable modes of operation for an exemplary buffer 520 are available. One mode of operation is a “bypass mode.” In this mode, data is passed to the next unit with almost no additional storage.

**[0039]** Another mode of operation is a “replay mode.” In the replay mode, the buffer 520 “replays” the same data samples multiple times. This provides various options for further processing. The buffer 520 may also be used to play back data faster as compared to incoming data, and is therefore able to perform additional operations in the same amount of time. For example, if incoming data is stored at 250 Mchips/second, but the processing unit 530 is operating at 1 GHz, the same stored data can be replayed up to 4 times.

**[0040]** The data stored in the buffer 520 may also be replayed and then processed with different spreading code chips from different transmitters. If the correlation processor 532 for a set of 4 transmitters operates at 4 times the rate at which chips are accumulated in memory, then the correlation processor 532 would be able to process the spreading code chips from 16 transmitters without losing data.

**[0041]** By replaying the data from the buffer 520, correlations over multiple sets of range bins is possible. If the correlation processor 532, for example, can generate 256 range bins, the start/end of the TX code, or the RX code, or both, may be changed to increase the quantity of range bins. In addition, part of the previous or next PRI data may also be provided as necessary. If there is time for 4 replays (e.g. the processing speed of the correlation processor 532 is 4 times the rate at which samples are stored), the number of range bins may be increased from 256 to 1024.

**[0042]** By using the replay mode for the buffer operation in pulse mode described above, whereby the transmitter is ON for a short time interval and then OFF for another short interval, the receiver may detect targets in a first or initial processing. Knowing when the received signal samples correspond to reflections from near targets, those data samples (corresponding to the near targets) can be excised (set to 0). The correlation processing may then be repeated without the large samples from near targets. This allows for a better detection of far targets. In other words, once the large samples are removed from the set of data samples, the set of data samples may be processed again.

**[0043]** The replay mode may also be used to increase the unambiguous Doppler. By applying a frequency shift to the output of the buffer 520 before performing the Doppler processing (534), the set of Doppler frequency results shifts. For example, if the correlation samples are produced at a rate of 40,000 samples per second, the maximum unambiguous Doppler velocity is about 38m/second (85mph). The Doppler processor 534 would be able to estimate Doppler velocities between -38 m/s and +38 m/s. If the data out of the buffer 520 is multiplied on a chip-by-chip basis by an exemplary sinusoidal signal with a frequency of 40kHz, corresponding to a Doppler velocity of 76 m/s, the Doppler processor 534 would be able to estimate Doppler velocities between +38 and +114 m/s.

**[0044]** A further mode of operation is “throttle mode 1.” In this mode, the correlators 532 are operating on a partial duty cycle. If the ADC 480 produces 2 Gchips/s, the data is forwarded to the next processing block in the digital pipeline (the post-buffer processor 530) at a slower rate, e.g. 800 Megasamples-per-second (Ms/s). Only a part of the data stored in the buffer 520 is forwarded to the post-buffer processor 530. Therefore, the post-buffer processor 530 may operate at a 40% duty cycle.

**[0045]** Another mode of operation is “throttle mode 2.” This mode is also throttling the received data from the pre-buffer processor 510 so that the correlation processor 532 can process the data at a lower rate (up to 800 Mchips/s). This mode (“throttle mode 2”) may be used if the correlation processor 532 cannot match the speed of the pre-buffer

processing 510, or for example, to bypass incoming data from the ADC 480 (which is arriving at up to 2 Gigasamples-per-second (Gs/s)), to supply data to the correlation unit 532 at a much lower rate.

**[0046]** A further mode is a “debug and loopback mode.” In this mode a control processor 210, illustrated in FIGS. 2A and 2B, may write specific data into the buffer 520. The control processor 210 may then trigger the data forward for processing to mimic an actual radar scan. The control processor 210 may also configure the buffer 520 and specify how many chips are to be stored. For the loopback mode, the control processor 210 may store a small subset of data and provide a start pointer, a stored length of data, and a total number of chips to be sent. The buffer 520 may then repeat the same pattern until a specified number of output chips have been made available to the correlation processor 532. Two loopback modes are possible. A first exemplary loopback mode allows the data to be reprocessed by the pre-buffer processing 510, as illustrated by a connection 515 in Figure 5. This allows, for example, additional interference mitigation. Alternatively, the loopback may not include further pre-processing 510.

**[0047]** Another possibility (an exemplary second loopback mode) is that the buffer 520 may be written by the control processor 210, which allows the control processor 210 to write very specific data samples into the buffer 520 and play it back, and have the samples processed by the post-buffer processor 530. This allows the use of synthetic input data for verification purposes, but it can also be used as a HW accelerator for RDC processing.

**[0048]** Another mode is known as “quiet mode 1.” In this mode the buffer 520 may store all incoming data (both RX and TX data) without forwarding anything to the correlation processing unit 532 while the data is being received. This may ensure that the digital noise from the correlators 532 and the rest of the digital post-buffer processor 530 will be minimal. In other words, the post-buffer processor 530 is in a sleep mode while the RF front end pre-buffer processor 510 is storing data in the buffer 520. As soon as the received signal has been completely received for a certain time interval, the stored data

may be forwarded to the post-buffer processor 530 for further processing, such as performed by the correlation processor 532. The maximum number of chips stored preferably could be up to 22,000 chips.

**[0049]** An alternative to quiet mode 1 is “quiet mode 2.” Quiet mode 2 is similar to quiet mode 1. In quiet mode 2, the data is forwarded to the buffer 520 right from the ADC 480. In other words, even the pre-buffer processor 510 is not operating when the data is stored (in the buffer 520).

**[0050]** A further mode is the “raw data capture mode.” In some situations, it may be desirable to have more data available for just one receiver of the receiver pipeline. Because a buffer 520 of a particular receiver is shared between receivers, if only one receiver is active, the buffer 520 of that receiver may optionally store more samples from that receiver by using memory for the receiver’s samples that is normally allocated to the other receivers. The buffer 520 may also be used to capture raw data for calibration or further analysis since the buffer 520 can store data samples from all the receivers simultaneously at a rate that is faster than at which the samples are generated. In addition, the storing of samples may be stopped or triggered based on certain events, e.g. an external pin, or saturation, or other internal events, and may therefore be used as a digital oscilloscope for debugging.

**[0051]** Another mode is the “functional safety mode.” Periodically, a predefined pattern may optionally be used and passed to the post-buffer processor 530. A cyclic redundancy check (CRC), an error detecting code, is calculated based on the result of the post-buffer processing (530). That is, the data at the output of the post-buffer processor 530 is used to generate CRC parity checks. These parity checks are stored in memory (the buffer 520). The number of parity checks stored is much smaller than the number of data bits at the output of the post-buffer processor 530, so storing these parity checks does not require a significant amount of memory. Subsequently, the same data may be passed to the post-buffer processor 530 and another CRC may then be computed. The new CRC is compared to the previously computed CRC. If the two CRCs do not match, an indication of hardware fault is generated. This mode may be

used to provide periodic checks to see if the hardware is processing data properly or if there is a hardware error.

**[0052]** Changes and modifications in the specifically described embodiments can be carried out without departing from the principles of the present invention, which is intended to be limited only by the scope of the appended claims, as interpreted according to the principles of patent law including the doctrine of equivalents.

## CLAIMS:

1. A radar sensing system for a vehicle, the radar sensing system comprising:
  - a transmitter configured for installation and use on a vehicle, and configured to transmit radio signals;
  - a receiver configured for installation and use on the vehicle, and configured to receive radio signals that include the transmitted radio signals transmitted by the transmitter and reflected from objects in an environment;
  - a controller configured to control the transmitter and the receiver;
  - wherein the receiver comprises: (i) an analog-to-digital converter (ADC) configured to sample the radio signals and output data samples; (ii) a pre-buffer processor configured to selectively perform signal processing operations on the ADC samples, (iii) a buffer configured to store the output data samples from the pre-buffer processor and release the stored data samples; and (iv) a post-buffer processor configured to receive the released data samples and perform processing operations on the released data samples, as defined by the controller; and
  - wherein the controller is configured to selectively control an operation of the post-buffer processor in a series of operations, such that a different processing is performed in a first processing as compared to a later second processing.
2. The radar sensing system of claim 1, wherein the post-buffer processor is configured to perform at least one of range processing, velocity processing, and angular processing on the released data samples, as defined by the controller.
3. The radar sensing system of claim 2, wherein the post-buffer processor is configured to perform complex signal rotation to shift a frequency of the data samples, as defined by the controller.
4. The radar sensing system of claim 2, wherein the post-buffer processor is configured to perform a cyclic redundancy check (CRC) on selected data codes after processing the data samples, as defined by the controller.

5. The radar sensing system of claim 2, wherein the post-buffer processor is configured to perform correlation operations as part of the range processing.
6. The radar sensing system of claim 5, wherein the pre-buffer processor is configured to store samples in the buffer, and wherein the post-buffer processor is placed into a sleep mode, as defined by the controller, when the pre-buffer processor is actively storing data samples in the buffer.
7. The radar sensing system of claim 2, wherein the post-buffer processor is configured to selectively scale amplitudes of the data samples.
8. The radar sensing system of claim 7, wherein scaling an amplitude comprises setting a data sample to a value of zero.
9. The radar sensing system of claim 1, wherein the receiver further comprises a radio frequency (RF) front end configured to process the received radio signals to output processed radio signals.
10. The radar sensing system of claim 9, wherein the ADC is configured to sample the processed radio signals and output the data samples.
11. The radar sensing system of claim 9, wherein the post-buffer processor is configured to use data samples stored in the buffer to calibrate a radio frequency processing portion of the RF front end.
12. The radar sensing system of claim 9, wherein the post-buffer processor is configured to use data samples stored in the buffer to calibrate a digital processing portion of the RF front end.
13. The radar sensing system of claim 1, wherein the buffer is configured to selectively operate in one of a plurality of operational modes, as defined by the controller.

14. The radar sensing system of claim 13, wherein the buffer is configured to selectively release the stored data samples, as defined by the controller.
15. The radar sensing system of claim 13, wherein the buffer is configured to replay a sequence of stored data samples a plurality of times, and wherein the replayed sequence of stored data samples is processed differently as compared to a previous processing.
16. The radar sensing system of claim 13, wherein a first operational mode of the buffer is selected for the first processing, and wherein a second operational mode of the buffer is selected for the second processing.
17. The radar sensing system of claim 1, wherein the pre-buffer processor is configured to pass the ADC samples directly to the buffer for storage.

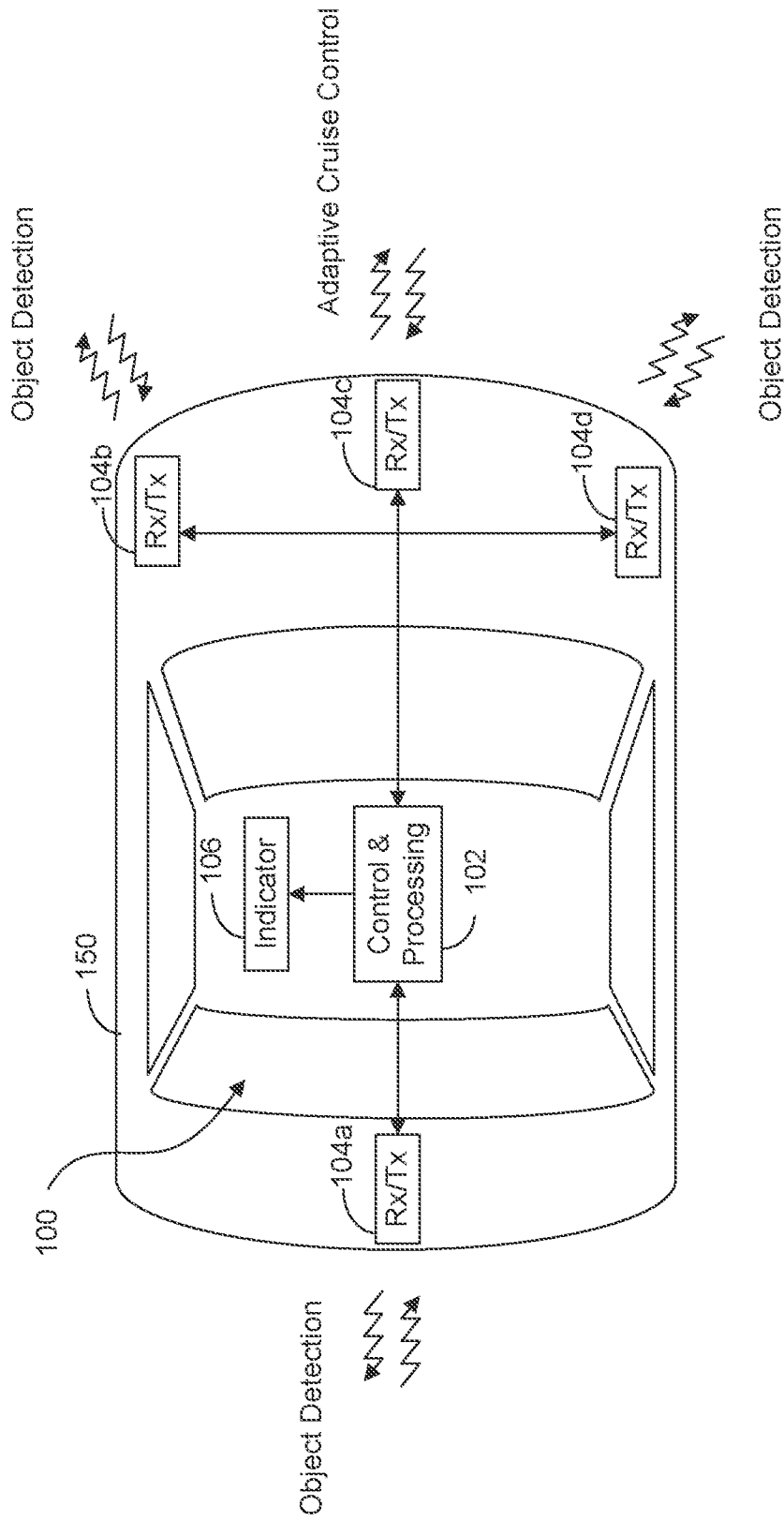

FIG. 1

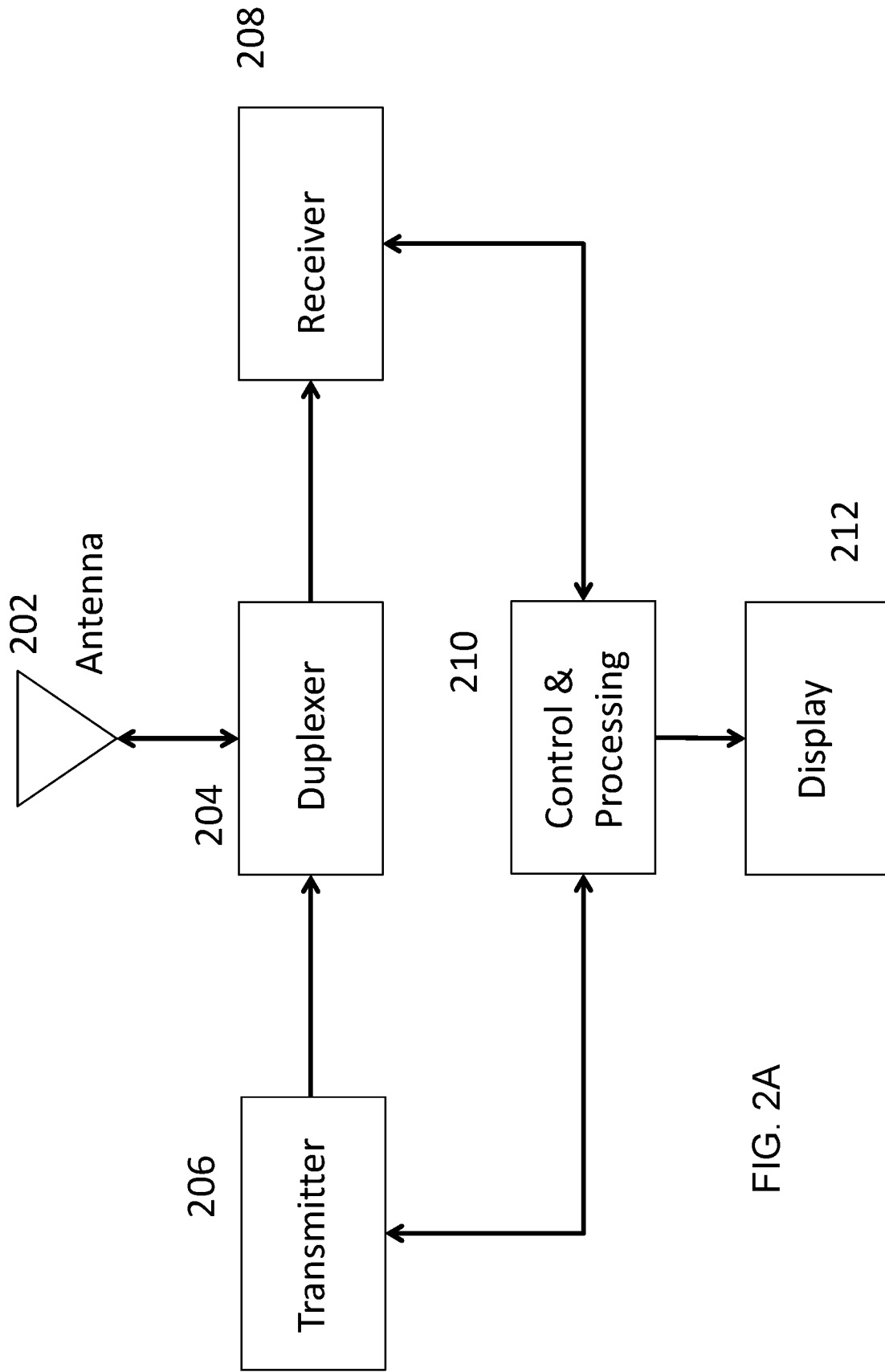

FIG. 2A

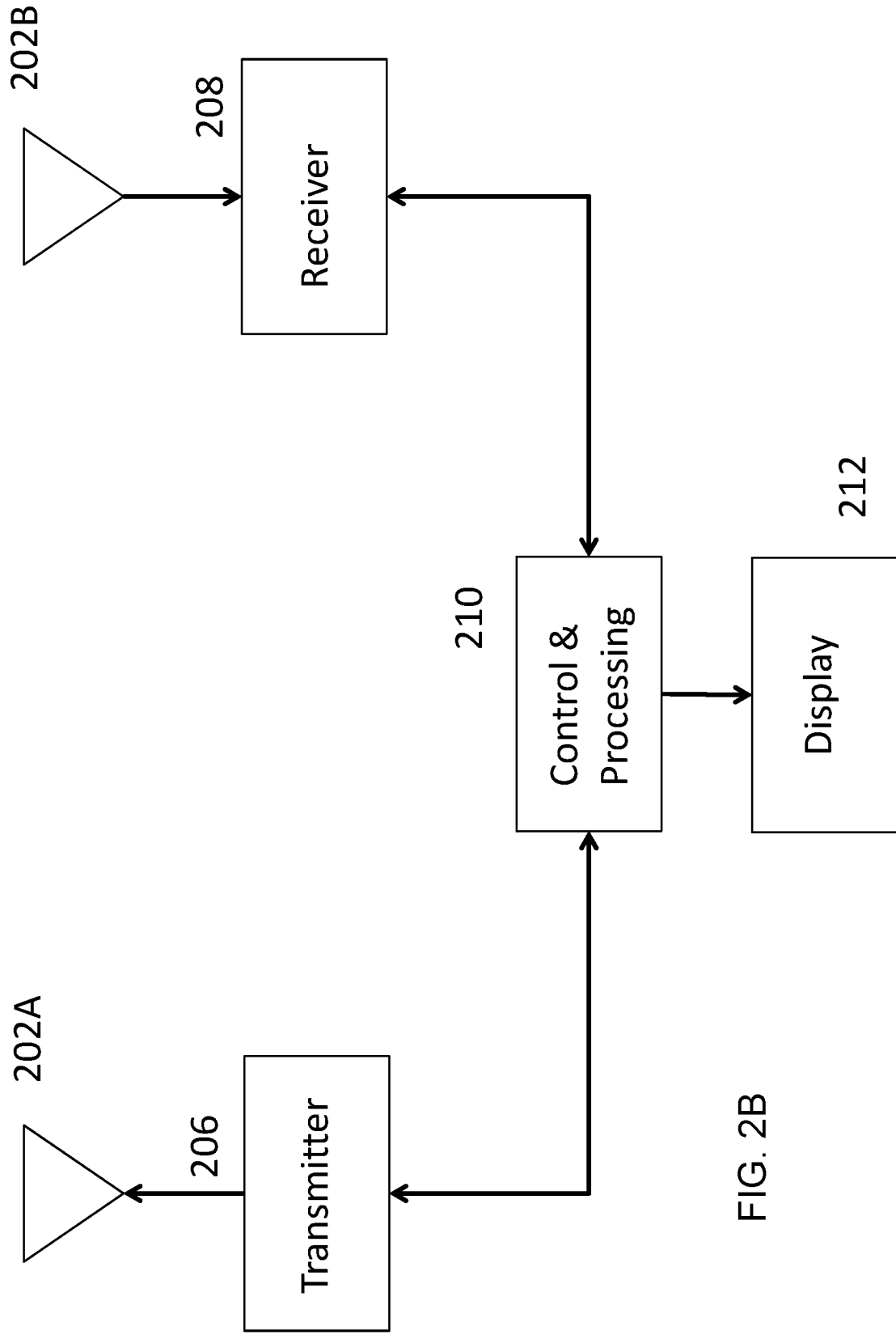

FIG. 2B

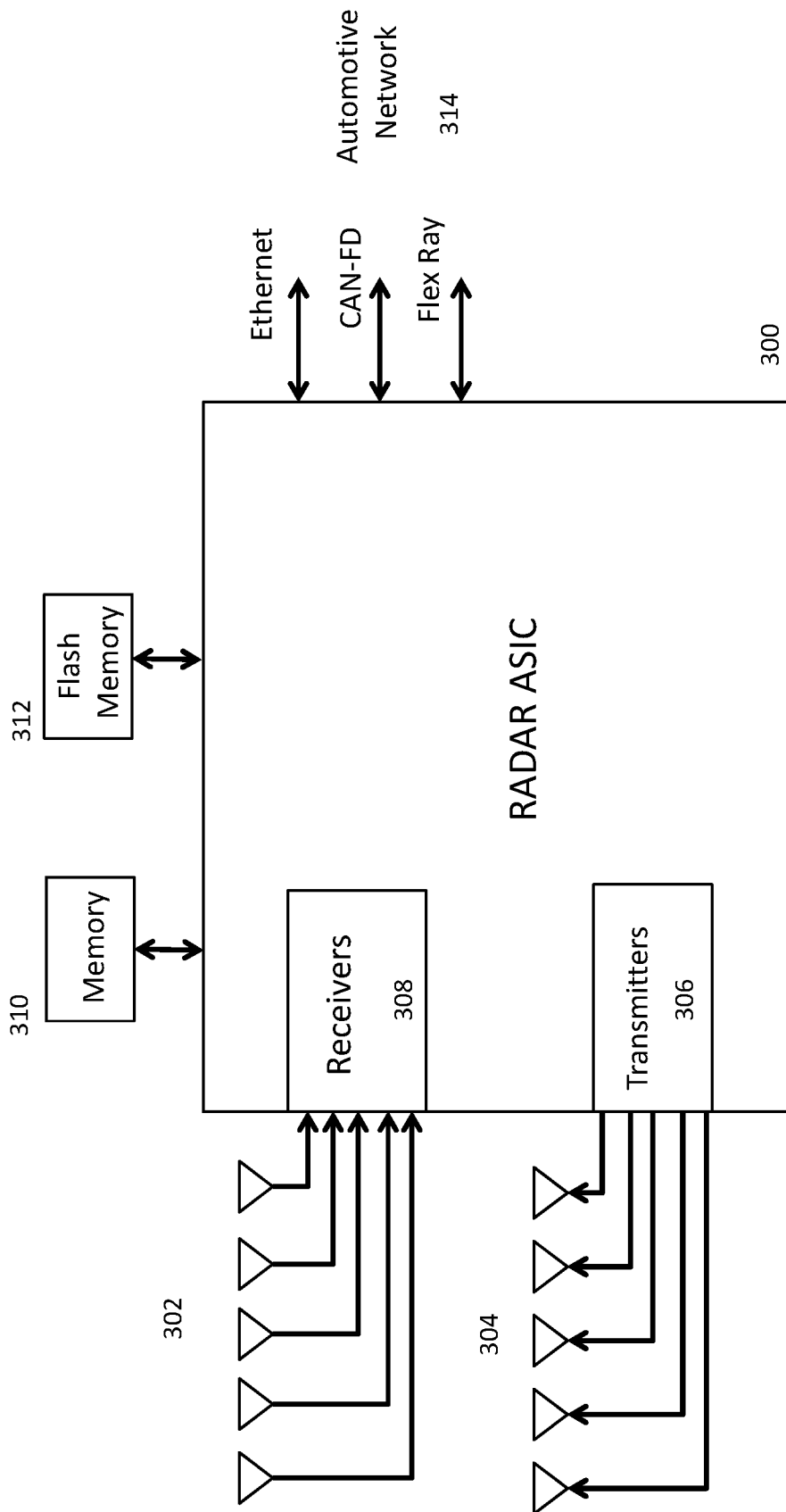

FIG. 3

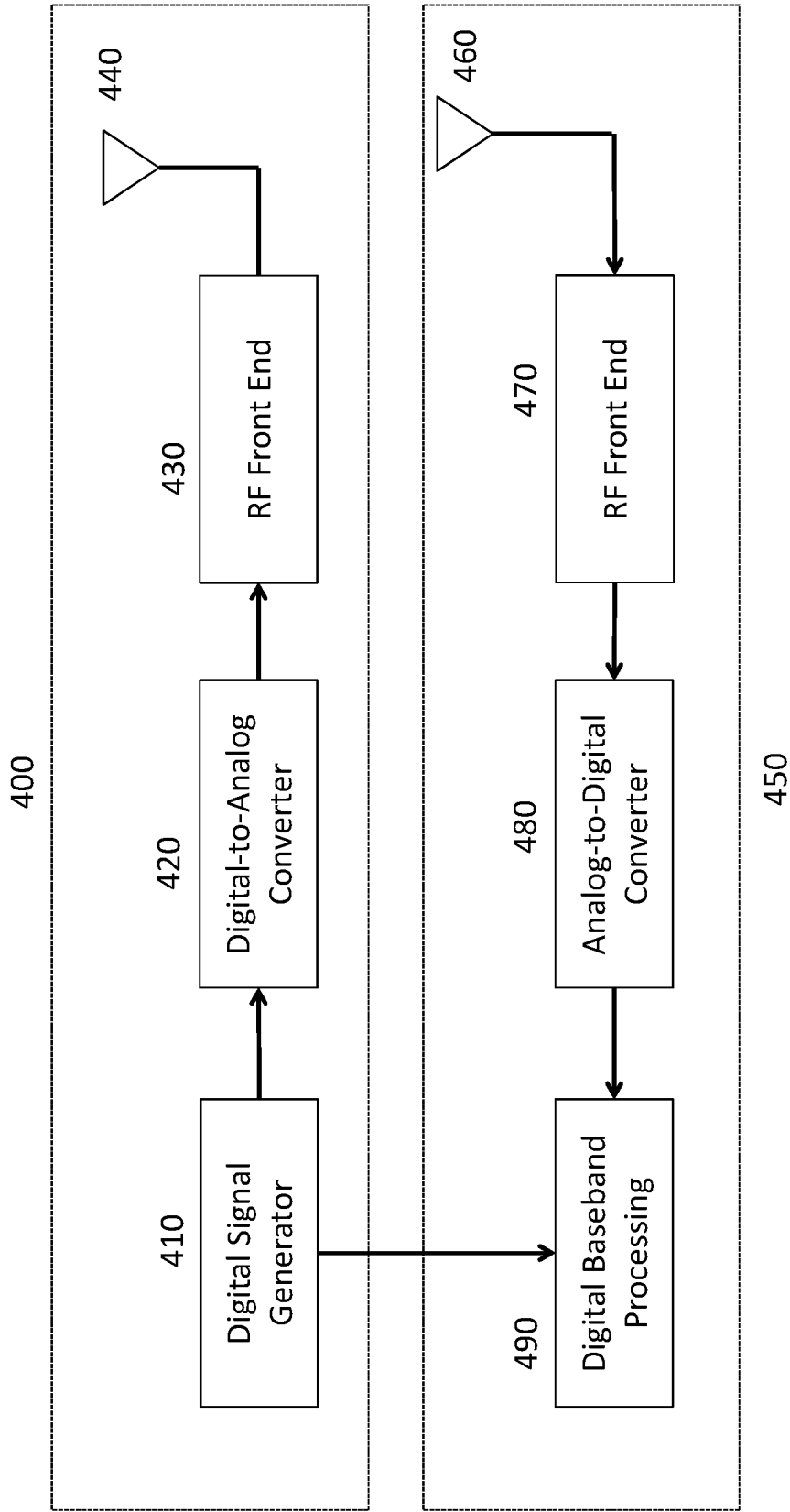
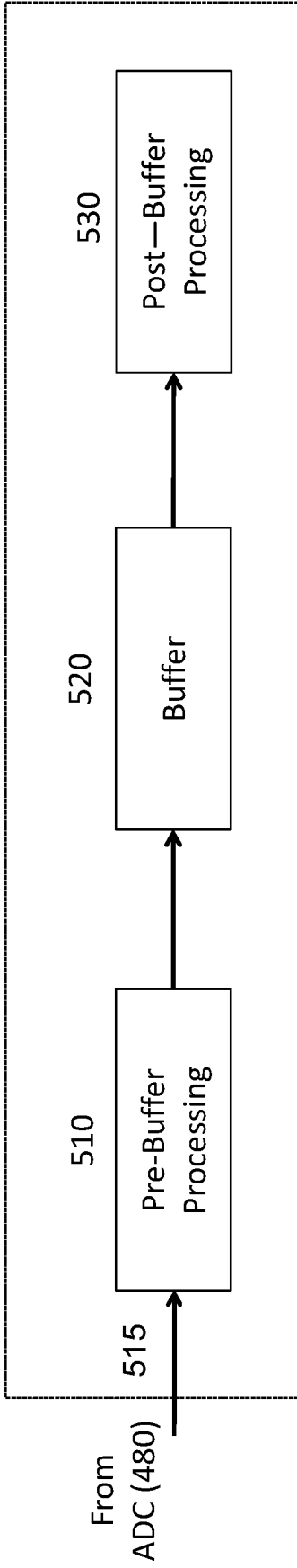

FIG. 4

490



6/6

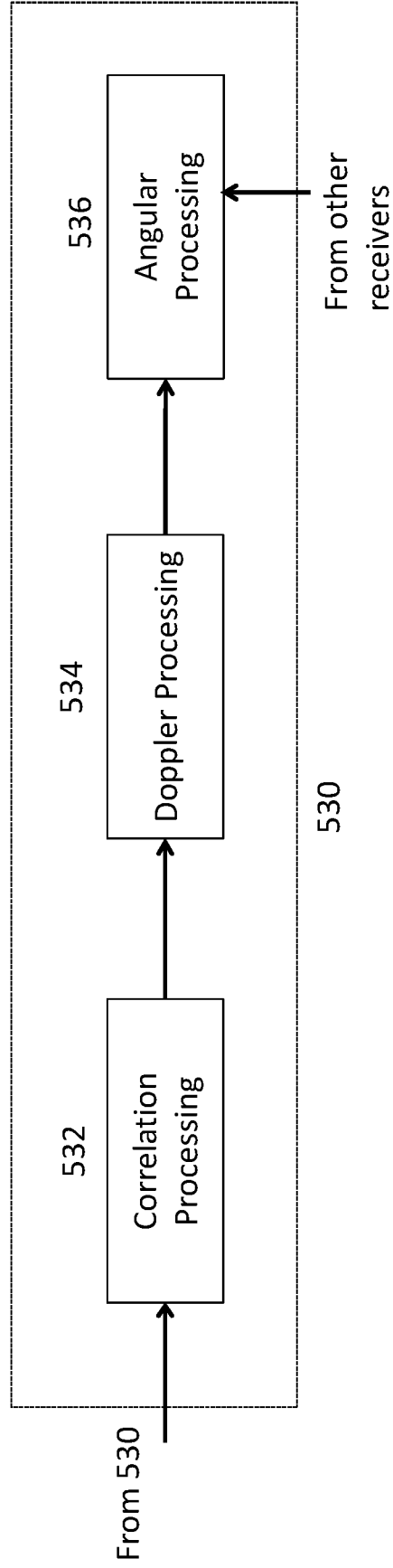

FIG 5

## INTERNATIONAL SEARCH REPORT

International application No.

PCT/IB 18/50819

## A. CLASSIFICATION OF SUBJECT MATTER

IPC(8) - G01S 13/00 (2018.01)

CPC - G01S 13/93, G01S 7/412, G01S 13/931, G01S 2013/9353, G01S 2013/9371, G01S 19/42, G08G 1/0104, H04N 21/231, G01S 13/345

According to International Patent Classification (IPC) or to both national classification and IPC

## B. FIELDS SEARCHED

Minimum documentation searched (classification system followed by classification symbols)

See Search History Document

Documentation searched other than minimum documentation to the extent that such documents are included in the fields searched

See Search History Document

Electronic data base consulted during the international search (name of data base and, where practicable, search terms used)

See Search History Document

## C. DOCUMENTS CONSIDERED TO BE RELEVANT

Category*	Citation of document, with indication, where appropriate, of the relevant passages	Relevant to claim No.
X	US 2017/023663 A1 (Texas Instruments, Inc) 26 January 2017 (26.01.2017); entire document, especially, abstract, FIG.1-3, 6,7, para [0017], [0023], [0027], [0028], [0036], [0037], [0041], [0042],[0049], [0051], [0052], [0057], [0059], [0088], [0090], [0092], [0095], [0099],	1-3, 5, 9-14, 16,17
Y		4, 6-8, 15
Y	US 5,581,464 A (Woll et al.) 03 December 1996 (03.12.1996); entire document, especially, abstract, col.5, ln 31-35	4
Y	US 5,691,724 A (Aker et al.) 25 November 1997 (25.11.1997); entire document, especially, abstract, FIG.24E, col.3, ln 36-39, col.26, ln 26-31, col.36, ln 20-45	6-8
Y	US 2003/0080713 A1 (Kirmuss) 01 May 2003 (01.05.2003); entire document, especially, abstract, para [0043], [0139]	15
A	US 2010/0289692 A1 (Winkler) 18 November 2010 (18.11.2010); entire document	1-17

 Further documents are listed in the continuation of Box C. See patent family annex.

## \* Special categories of cited documents:

"A" document defining the general state of the art which is not considered to be of particular relevance

"E" earlier application or patent but published on or after the international filing date

"L" document which may throw doubts on priority claim(s) or which is cited to establish the publication date of another citation or other special reason (as specified)

"O" document referring to an oral disclosure, use, exhibition or other means

"P" document published prior to the international filing date but later than the priority date claimed

"T" later document published after the international filing date or priority date and not in conflict with the application but cited to understand the principle or theory underlying the invention

"X" document of particular relevance; the claimed invention cannot be considered novel or cannot be considered to involve an inventive step when the document is taken alone

"Y" document of particular relevance; the claimed invention cannot be considered to involve an inventive step when the document is combined with one or more other such documents, such combination being obvious to a person skilled in the art

"&amp;" document member of the same patent family

Date of the actual completion of the international search

08 May 2018

Date of mailing of the international search report

23 MAY 2018

Name and mailing address of the ISA/US

Mail Stop PCT, Attn: ISA/US, Commissioner for Patents  
P.O. Box 1450, Alexandria, Virginia 22313-1450  
Facsimile No. 571-273-8300

Authorized officer:

Lee W. Young

PCT Helpdesk: 571-272-4300  
PCT OSP: 571-272-7774