

REPUBLIC OF SOUTH AFRICA
PATENTS ACT, 1978

PUBLICATION PARTICULARS AND ABSTRACT

(Section 32(3)(a) – Regulations 22(1)(g) and 31)

Official Application No.		Lodging Date	Acceptance Date
21	01 2004/6181	22 3 AUGUST 2004	43 21-9-05

International Classification	Not for Publication
51 B65D	Classified By: McCALLUM RADEMEYER & FREIMOND

Full Name(s) of Applicant(s)	
71	MEADWESTVACO PACKAGING SYSTEMS LLC

Full Name(s) of Inventor(s)	
72	LE BRAS, Philippe; MARIÉ, Philippe

Earliest Priority Claimed		
Country	Number	Date
33 GB	31 0202869.4	32 7 February 2002

Title of Invention	
54	CARTON WITH OVERLAPPED BASE PANELS AND BLANK THEREFOR

57	Abstract (not more than 150 words)	Number of Sheets	33
----	------------------------------------	------------------	----

(57) Abstract: A carton of the wrap-around type has a pair of overlapped base panels (12,20). One of the bases panels (12) which carries a locking tab (38) overlies a tongue (42) protruding from the end edge of the other base panel (20). The protruding tongue (42) is formed with a complementary locking aperture (40) engaged by the locking tab (38) to secure the overlapped panels (12, 20) together. On either side of the locking tab (38), the said one base panel (12) has a hinged tab (50, 52) protruding from the end edge of that panel. Each of the hinged tabs underlies the end edge (44,46) of the other base panel (20), one on each side of the protruding tongue (42). This 'over and under' arrangement presents less of an externally overlapped edge than is the case of a simple complete overlap and thus mitigates against the base panels being skewed or prized apart leading to tearing and/or dislodgment of the locking means.

ADVERTISEMENT DRAWING

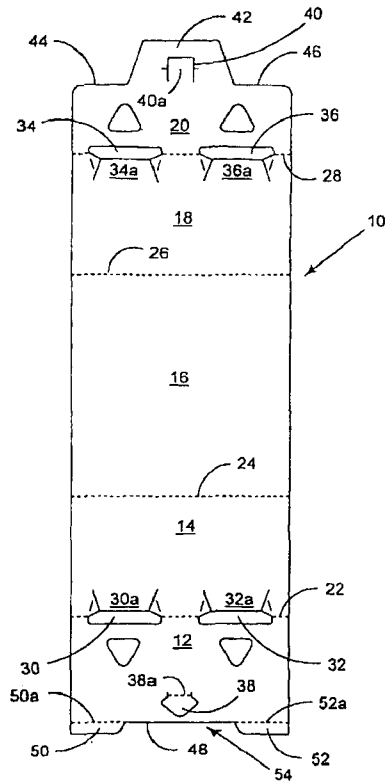

- 1 -

CARTON WITH OVERLAPPED BASE PANELS
AND BLANK THEREFOR

Background of the Invention

5

This invention relates to a carton with overlapped base panels and to a blank for forming the carton. More specifically, the invention relates to a wrap-around carton in which the base panels are overlapped and secured together by a single punch lock. Punch locks are well known and comprise a locking tab formed in one of the base panels which is driven through and secured in locking engagement with a receiving aperture defined by hinged tab in the other base panel.

10

It has been found that in cartons which have a single central punch lock which secure the base panels together two problems are experienced. One problem relates to the vulnerability of the lock to tearing, which sometimes occurs when the base panels are prized out of face contacting relationship with one another, for example, when the carton is stacked on a supermarket shelf, which has a tendency to put a tearing stress on the lock. Another problem encountered is that the base panels tend to pivot or skew relative to one another about the lock which also can cause tearing of the lock, or disengagement of the lock, which then destroys the integrity of the carton so that for packaging and marketing purposes it is completely useless.

15

20

The present invention seeks to provide a carton having a base panel arrangement so that the panels are not overlapped in the conventional way, i.e. where one panel end edge completely overlaps the other panel end edge, but rather are overlapped in an 'over and under' arrangement.

25

A known carton and blank of the wrap-around type is disclosed in GB 1 493 811 which includes shaped base panels in which one of the base panels includes a series of three punched locks all disposed along a tongue of the panel and the complementary locking

30

- 2 -

apertures are formed in the opposite base panel adjacent an end edge which is recessed from the rest of that panel.

There is no disclosure of the panels being overlapped in other than the conventional manner and, indeed, if the 'over and under' overlapping arrangement envisaged by the present invention were to be adopted then the punch locks could not be brought into register with the complementary locking apertures so that the base panels of the carton could not be locked together.

Summary of the Invention

The present invention seeks to overcome or at least mitigate the problems of the prior art.

One aspect of the present invention provides a carton comprising first and second overlapping panels provided respectively with mutually engaged male and female punch-lock arrangement and alignment means for facilitating alignment of the locking tabs during the panel interlocking process. The alignment means comprises a tongue protruding from an end edge of the first panel and a pair of flaps hinged in a spaced arrangement to an end edge of the second panel. Each of the hinged flaps underlies the end edge of the first panel, one on each side of the protruding tongue.

Preferably, the second panel is disposed over the tongue while the hinged flaps are disposed under the first panel in engagement with the opposed side edges of the tongue.

According to an optional feature of this aspect of the present invention, the protruding tongue includes a locking aperture which is engaged by a locking tab disposed adjacent the end edge of the second panel to secure the overlapping first and second panels together. Preferably, the aperture is defined by said female locking tab.

A second aspect of the present invention provides a carton for accommodating at least one article which carton includes a pair of overlapping base panels which are secured together

- 3 -

along a part or parts only over the overlap so that an exposed edge of an unsecured panel is exposed externally of the carton. An end edge part of one base panel is overlapped externally of the carton, relative to an end edge part of the other base panel, and an adjacent end edge part of the other base panel is overlapped externally of the carton relative to another end edge part of the one base panel.

Preferably, the end edge part of the one base panel is secured to the end edge part of the other base panel, whereas the adjacent end edge part of the other base panel is left unsecured to the one base panel.

In some embodiments, the end edge part of the one base panel is a part of that panel intermediate the opposite extremities of its end edge and wherein the adjacent end edge part of the other base panel comprises a pair of spaced end edge parts flanking, one of each of the intermediate edge part.

The intermediate edge part of the one panel may overlap a protruding tongue disposed intermediate the pair of spaced end edge portions.

Preferably, the intermediate edge part of the one panel is a recessed edge part of the end edge of that panel and is flanked by spaced protruding tabs.

Alternatively, the end edge parts flanking the protruding tongue may overlap respective ones of the protruding tabs.

According to an optional feature of the second aspect of the present invention, the protruding tabs are hinged to the adjacent parts of the one base panel.

According to a further optional feature of this aspect of the present invention, the intermediate end edge part of the one base panel and the adjacent end edge parts of the other base panel are substantially aligned.

- 4 -

A second aspect of the present invention provides a blank comprising first and second overlapping panels provided respectively with mutually engaged male and female punch-lock arrangement and alignment means for facilitating alignment of the locking tabs during the panel interlocking process, the alignment means comprising a tongue protruding from an end edge of the first panel and a pair of flaps hinged in a spaced arrangement to an end edge of the second panel and wherein each of the hinged flaps underlies the end edge of the first panel, one on each side of the protruding tongue.

Preferably, the protruding tongue includes a locking aperture which is engaged by a locking tab disposed adjacent the end edge of the second panel to secure the overlapping first and second panels together.

Preferably, the aperture is defined by said female locking tab

Brief Description of the Drawings

Exemplary embodiments of the invention will now be described by way of example only, with reference to the accompanying drawings, in which:-

FIGURE 1 is a plan view of a blank for forming a wrap-around carton according to one embodiment of the invention;

FIGURE 2 is a perspective view of the blank partially applied to a group of four containers, which in this embodiment are pots containing dairy produce;

FIGURE 3 is a plan view of the loaded carton showing the base panels being brought into an overlapping relationship;

FIGURE 4 is a plan view of the base panel similar to Figure 3, but in which the locking tab is almost in registry with the locking aperture in order that the locking tab can be engaged;

- 5 -

FIGURE 5 is a plan view of the overlapped base panels of the completed carton in which the base panels are fully overlapped and locked together; and

FIGURE 6 is a perspective view of the loaded carton according to one embodiment of the invention as shown from above and one end.

Detailed Description of the Preferred Embodiment

Referring to the drawings and, in particular, Figure 1, there is shown a blank 10 formed from paperboard or sheet material having a similar function. In this embodiment, the blank is of the well-known wrap-around type to be wrapped around a set of containers, for example a group of pots 'P' (Figure 2). The elongate blank 10 comprises in series a first base panel 12, a first side wall panel 14, a top panel 16, second side wall panel 18, and a second base panel 20 hinged one to the next along successive transverse fold lines 22, 24, 26 and 28 respectively.

In one class of embodiments, in order to prevent end-wise movement of the articles when they are received in the sleeve formed from the blank, heel retention apertures 30, 32 are formed partially in the first base panel 12 and partially in the side wall panel 14 along the transverse fold line 22. The heel retention openings are enhanced by hinged flaps 30a, 32a respectively. Similar heel retention apertures 34, 36 are formed partially within second base panel 20 and partially within side wall 18 along transverse fold line 28. These heel retention openings also are enhanced by hinged flaps 34a, 36a respectively.

First base panel 12 is formed with a "male" locking tab 38 of the punch-lock type. These locks are well known in the art and the locking tab is adapted to be hinged about its base hinge line 38a out of the plane of the blank and received in a locking aperture 40 defined, in this embodiment, by a hinged tab 40a ("female" tab) formed in the second base panel 20 when the locking tab is brought into registry with the locking aperture.

30

- 6 -

Normally in prior art arrangements, the base panels are simply overlapped by bringing the panel having the locking tab, externally of the carton, into overlapping relationship with the panel having the locking aperture. However, in the present invention, the panels are overlapped in an "over and under" arrangement. To this end, the extreme end edge of second
5 base panel 20 is formed with a protruding tongue 42 which protrudes beyond the adjacent parts 44, 46 of the remainder of the end edge of base panel 20. Preferably, the locking aperture 40 is formed within the protruding tongue 42. At the opposite end of the blank the first base panel 12 is formed with a central end edge 48 which is flanked by a pair of hinged flaps 50, 52 having hinge lines 50a, 52a respectively to define a recess.

10

In order to form the completed carrier in flat collapsed condition from the blank, a series of sequential folding operations are required and will be described further with reference to Figures 2 to 6 of the drawings. The folding operations can be performed in one or more straight line machines, so that the carton is not required to be rotated or inverted to complete
15 its construction. The folding process is not limited to that described below and can be altered according to particular manufacturing requirements.

20

Referring now to Figures 2 to 4 of the drawings, the blank is applied to the group of pots 'P' as shown so that the base panel 20 is brought into contact with the bases of the pots and the top wall 16 of the blank and the tops of the pots. Thus, peripheral heel portions of two adjacent pots are received in respective ones of the heel retention openings 34, 36.

25

The base panel 12 is then manipulated to overlie the other two remaining pots and during the course of manipulation the hinged flaps 50, 52 are folded inwardly of the carton along fold lines 50a, 52a respectively and are then introduced in sliding engagement beneath the end edge portions 44, 46 on either side of the projecting tongue 42 of end panel 20, shown in Figure 3. Likewise, as the panels are brought into sliding overlapping relationship, the tongue 42 passes through recess 54 and beneath the end edge portion 48 of base panel 20 shown in Figure 4.

30

- 7 -

Thus, the panels are overlapped in an 'under and over' arrangement with the tongue 42 of base panel 20 underlying an intermediate area of base panel 12, while the adjacent end edges 44, 46 are overlying the hinged flaps 50, 52 shown in Figure 5.

5 The overlapping engagement is best shown with reference to Figures 3 and 4. With reference to Figure 5, when the base panels 12 and 20 are fully overlapped, it will be seen that the locking tab 38 is brought fully into overlying registry with the locking aperture 40 and thereafter it can be punch locked into locking engagement so as to secure the base panels 12, 20 together. When fully engaged in overlapping relationship, the end edge 48 of base panel
10 12 is in substantial alignment with the end edge portions 44, 46 of base panel 20.

Thus, when the base panels are fully overlapped in their 'over and under' arrangement and the securing lock engaged, there is only a relatively short run of exposed base panel, i.e. the recessed end edge 48 of base panel 12, which is vulnerable to being prized apart from base
15 panel 20. However, the recessed end edge 48 is within the intermediate locked area of the base panels and is thus resistant to being lifted away from base panel 20.

Likewise, the 'over and under' locking arrangement prevents skewing, that is relative rotation of the base panels, around the central lock which was a disadvantageous feature of known
20 conventionally overlapped base panels.

The completed loaded carton is shown in perspective view in Figure 6 of the drawings in which one of the hinged flaps is shown beneath the base of one of the pots.

25 It will be recognized that as used herein, directional references such as 'top', 'base', 'end', 'side', 'upper', 'lower', 'inner' and 'outer' do not limit the respective panels to such orientation but merely serve to distinguish these panels from one another. Any reference to hinged connection should not be construed as necessarily referring to a single fold line only; indeed, it is envisaged that hinged connection can be formed from one or more of one of the
30 following: a score line, a frangible line or a fold line, without departing from the scope of the invention.

- 8 -

It should be understood that numerous changes may be made within the scope of the invention. For example, the carton may be adapted to accommodate a single article or more than two articles. However, the size and shape of the apertures and panels may be adjusted
5 according to the particular requirements of the articles to be packaged and other known article retention means may be employed. The present invention and its preferred embodiment relates to a carton which is shaped to provide satisfactory rigidity to hold items such as primary containers securely but with a degree of flexibility. The shape of the blank minimizes the amount of paperboard required for the carton. The items can be applied to the
10 carrier by hand or automatic machinery. It is anticipated the invention can be applied to a variety of carton or tray types and not limited to those of the wraparound sort.

- 9 -

CLAIMS

1. A carton comprising first and second overlapping panels provided respectively with mutually engaged male and female punch-lock locking tabs and alignment means for facilitating alignment of the locking tabs during the panel interlocking process, the alignment means comprising a tongue protruding from an end edge of the first panel and a pair of flaps hinged in a spaced arrangement to an end edge of the second panel and wherein each of the hinged flaps underlies the end edge of the first panel, one on each side of the protruding tongue.
2. A carton according to claim 1 wherein the second panel is disposed over the tongue while the hinged flaps are disposed under the first panel in engagement with the opposed side edges of the tongue.
3. A carton according to claim 1 or claim 2 wherein the protruding tongue includes a locking aperture which is engaged by the male locking tab disposed adjacent the end edge of the second panel to secure the overlapping first and second panels together.
4. A carton according to claim 3 wherein the locking aperture is defined by said female locking tab.
5. A carton for accommodating at least one article which carton includes a pair of overlapping base panels which are secured together along a part or parts only over the overlap so that an exposed edge of an unsecured panel is exposed externally of the carton characterized in that an end edge part of one base panel is overlapped externally of the carton, relative to an end edge part of the other base panel, and an adjacent end edge part of the said other base panel is overlapped externally of the carton relative to another end edge part of the said one base panel.

- 10 -

6. A carton according to claim 5 wherein the said end edge part of the said one base panel is secured to the said end edge part of said other base panel, whereas the adjacent end edge part of the said other base panel is left unsecured to said one base panel.
- 5 7. A carton according to claim 6 wherein the said end edge part of the said one base panel is a part of that panel intermediate the opposite extremities of its end edge and wherein the adjacent end edge part of the said other base panel comprises a pair of spaced end edge parts flanking, one of each said of, said intermediate edge part.
- 10 8. A carton according to claim 7 wherein the intermediate edge part of the said one panel overlaps a protruding tongue disposed intermediate the said pair of spaced end edge portions.
9. A carton according to claim 8 wherein the intermediate edge part of the said one panel is a recessed edge part of the end edge of that panel and is flanked by spaced protruding tabs.
- 15 10. A carton according to claim 5, wherein the said end edge parts flanking said protruding tongue overlap respective ones of the said protruding tabs.
11. A carton according to claim 9 or claim 10 wherein the protruding tabs are hinged to
20 the adjacent parts of the said one base panel.
12. A carton according to any of claims 5 to 11 wherein the intermediate end edge part of the said one base panel and the adjacent end edge parts of the said other base panel are substantially aligned.
- 25 13. A blank for forming a carton according to any of claims 1 to 4 or claims 5 to 12.
14. A blank comprising first and second overlapping panels provided respectively with mutually engaged male and female punch-lock arrangement and alignment means for
30 facilitating alignment of the locking tabs during the panel interlocking process, the alignment means comprising a tongue protruding from an end edge of the first panel and a pair of flaps

- 11 -

hinged in a spaced arrangement to an end edge of the second panel and wherein each of the hinged flaps underlies the end edge of the first panel, one on each side of the protruding tongue.

- 5 15. A blank according to claim 14 wherein the protruding tongue includes a locking aperture which is engaged by a locking tab disposed adjacent the end edge of the second panel to secure the overlapping first and second panels together.
16. A blank according to claim 15 wherein the aperture is defined by said female locking
10 tab.

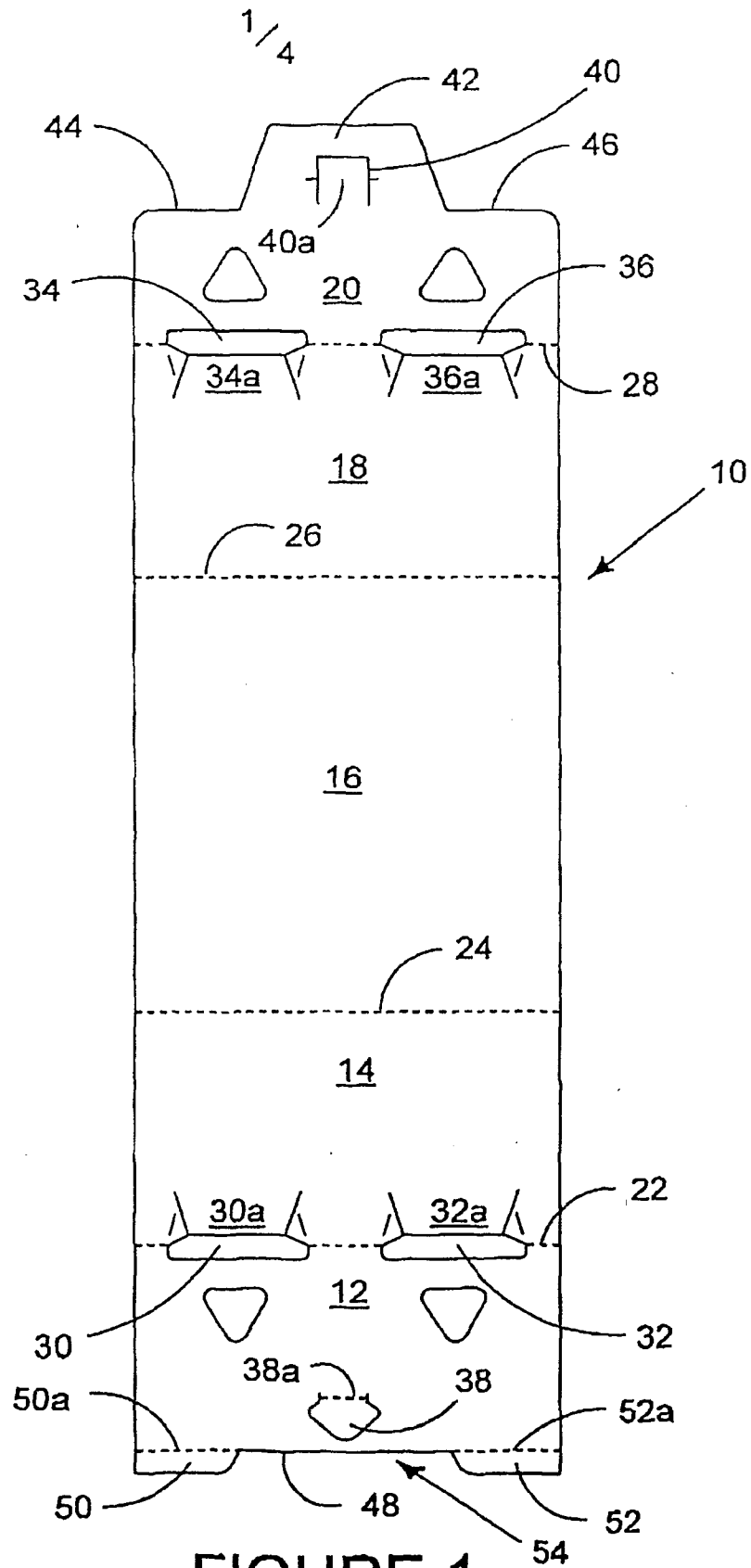

FIGURE 1

2/4

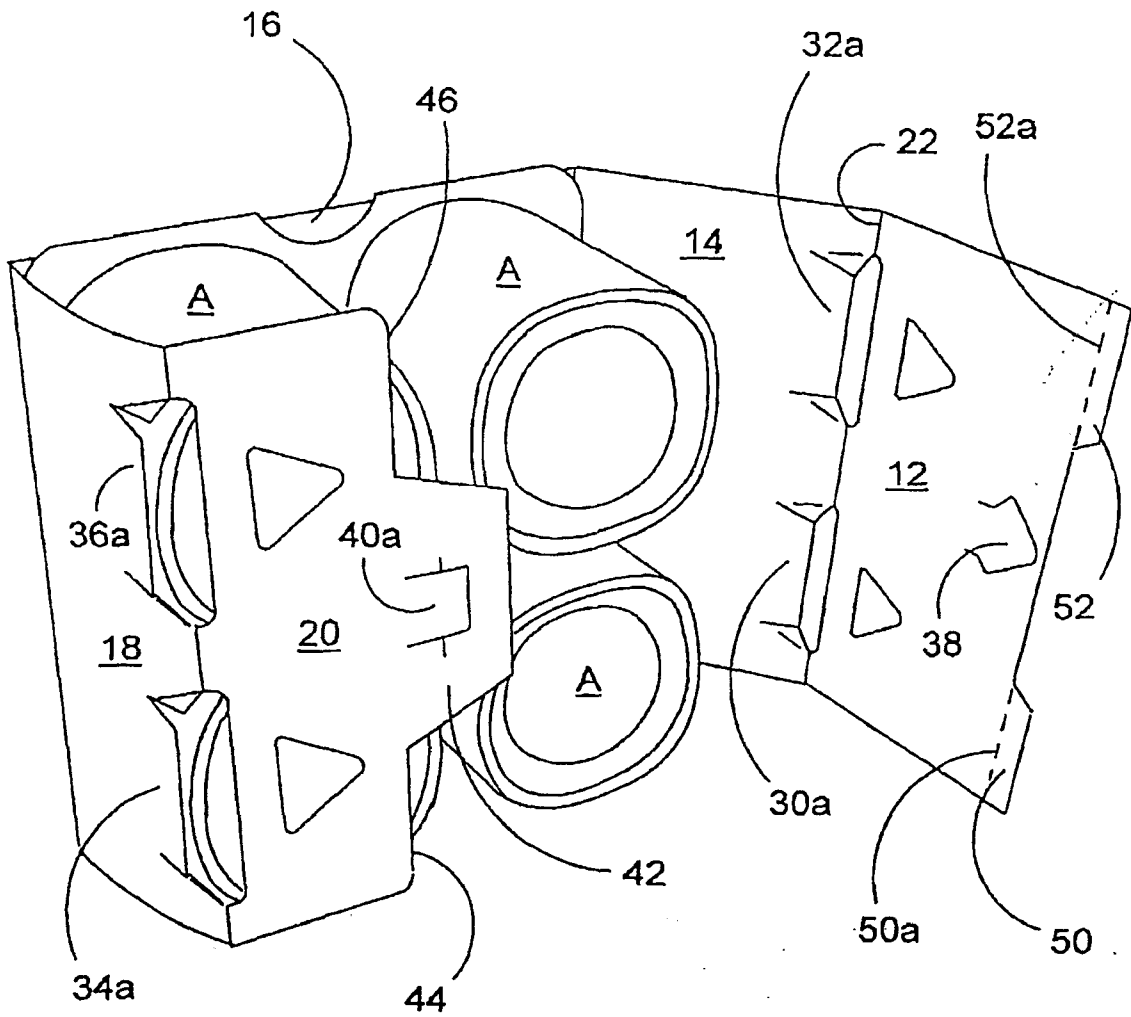

FIGURE 2

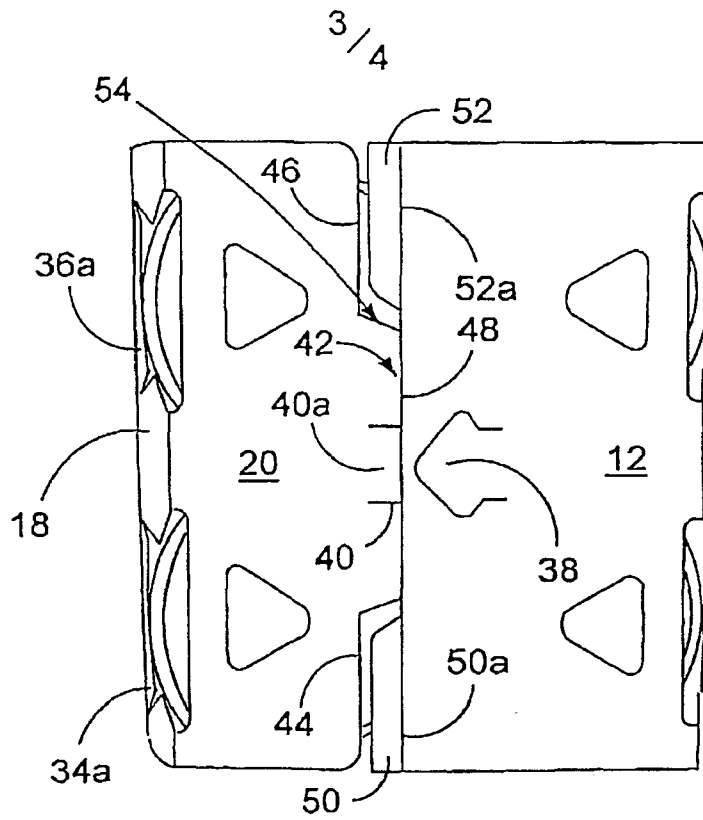

FIGURE 3

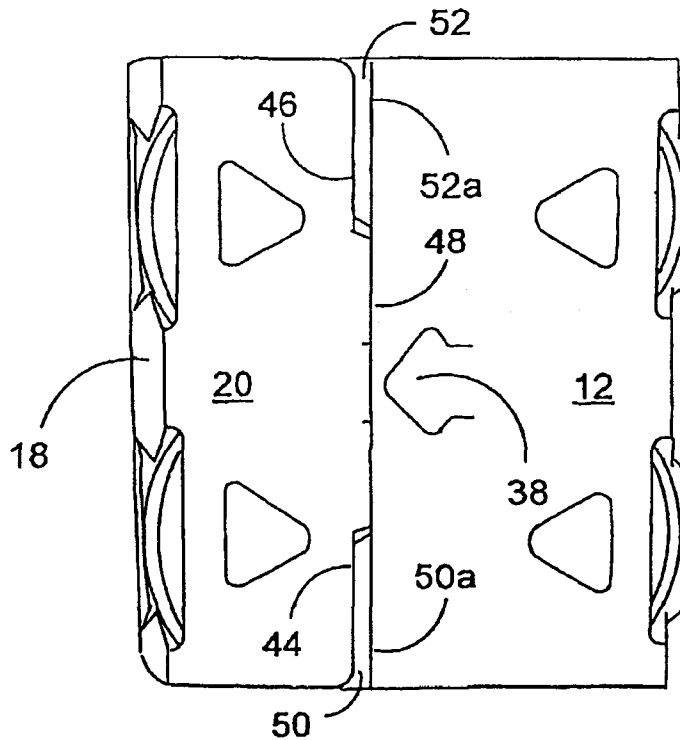

FIGURE 4

4 / 4

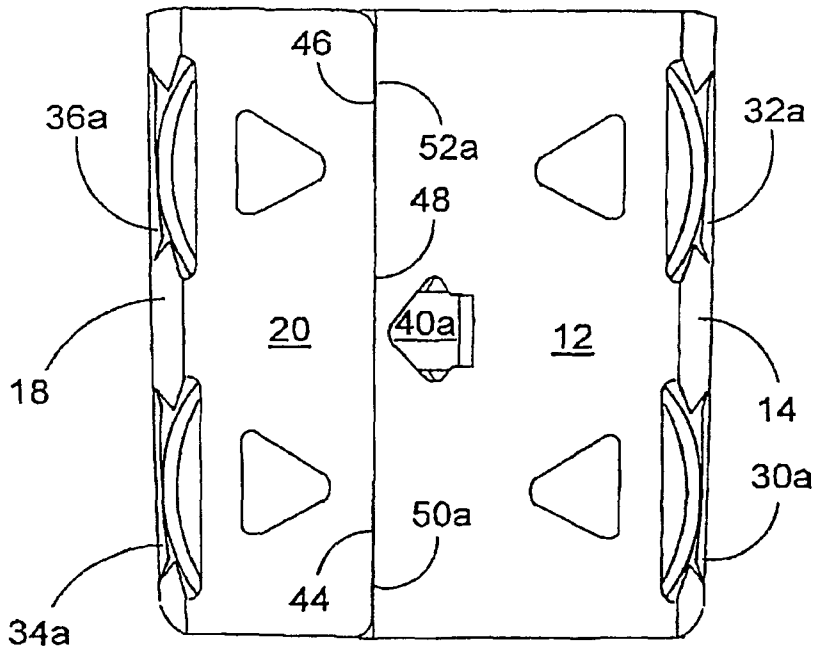

FIGURE 5

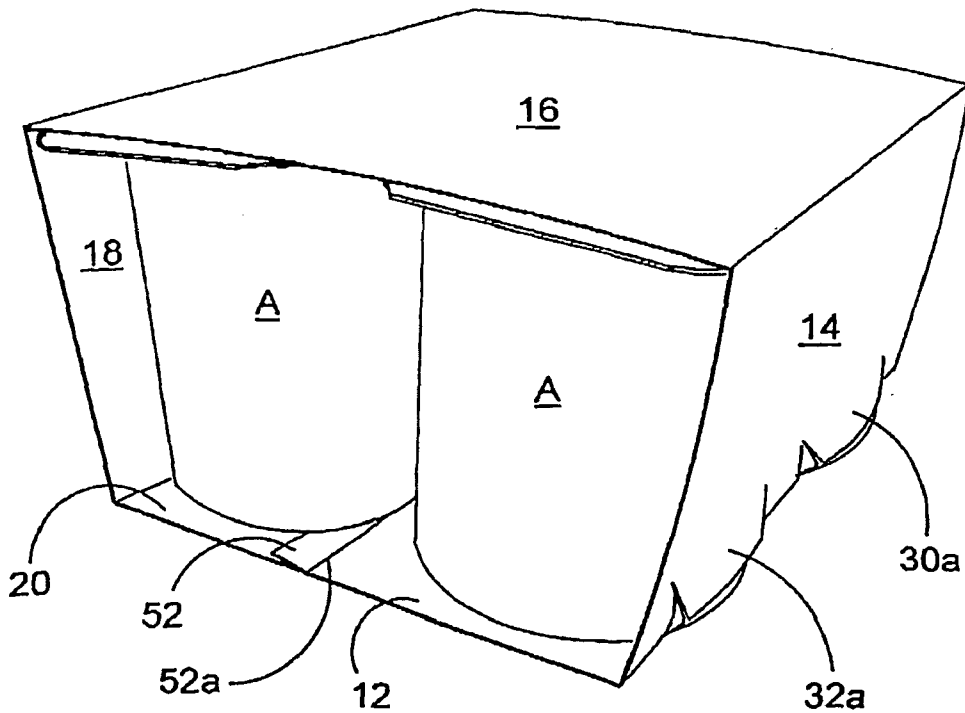

FIGURE 6