

(19)



(11)

EP 2 843 103 B1

(12)

EUROPEAN PATENT SPECIFICATION

(45) Date of publication and mention of the grant of the patent:
23.02.2022 Bulletin 2022/08

(51) International Patent Classification (IPC):
D06F 58/22 ^(2006.01) **D06F 25/00** ^(2006.01)

(21) Application number: **13182334.6**

(52) Cooperative Patent Classification (CPC):
D06F 58/22; D06F 25/00

(22) Date of filing: **30.08.2013**

(54) APPLIANCE FOR DRYING LAUNDRY WITH AUXILIARY DE-FLUFF FILTER

GERÄT ZUM TROCKNEN VON WÄSCHE MIT ZUSÄTZLICHEM ENTFUSLUNGSFITER

APPAREIL POUR SÉCHER LE LINGE AVEC FILTRE À PELUCHES AUXILIAIRE

(84) Designated Contracting States:
AL AT BE BG CH CY CZ DE DK EE ES FI FR GB GR HR HU IE IS IT LI LT LU LV MC MK MT NL NO PL PT RO RS SE SI SK SM TR

• **Contarini, Andrea**
I-33080 Porcia (PN) (IT)

(43) Date of publication of application:
04.03.2015 Bulletin 2015/10

(74) Representative: **Electrolux Group Patents**
AB Electrolux
Group Patents
S:t Göransgatan 143
105 45 Stockholm (SE)

(73) Proprietor: **Electrolux Appliances Aktiebolag**
105 45 Stockholm (SE)

(56) References cited:
EP-A1- 2 458 073 **EP-A1- 2 471 994**
DE-A1- 19 756 708 **GB-A- 1 554 725**
JP-A- 2008 079 855 **JP-A- 2010 005 097**
US-A1- 2011 271 543 **US-B1- 7 020 986**

(72) Inventors:
• **Viero, Massimo**
I-33080 Porcia (PN) (IT)

EP 2 843 103 B1

Note: Within nine months of the publication of the mention of the grant of the European patent in the European Patent Bulletin, any person may give notice to the European Patent Office of opposition to that patent, in accordance with the Implementing Regulations. Notice of opposition shall not be deemed to have been filed until the opposition fee has been paid. (Art. 99(1) European Patent Convention).

Description

[0001] The present invention relates to laundry machines comprising two de-fluff filter. The present invention refers to appliances for drying laundry, both for domestic and professional use.

[0002] Drying and washing/drying laundry machines - which will be referred to simply as laundry machine in the following - typically comprise a casing substantially parallepiped-shaped. The casing accommodates a laundry treating chamber, comprising a drum, generally rotatable, apt to contain the laundry to be dried, in the case of a washing/drying laundry machine, the drum is rotatably contained in a tub. A front panel of the casing has a loading opening to access the treating chamber for loading/unloading the laundry, and a door is provided for closing the loading opening, particularly during the laundry machine operation.

[0003] The casing also accommodates the electrical, electronic, mechanical, and hydraulic components necessary for the operation of the laundry machine. Particularly, laundry-drying capable machines features an air circuit (comprising, for example, fans, air ducts, a moisture condensing unit, a heating unit, *etc.*) adapted to heat air, blow it into the drum where it removes moisture from the laundry, suck out from the drum the moisturized air, de-moisturize the air and reiterate such actions thereby performing a laundry drying cycle.

[0004] During a washing and/or drying process, the laundry under treatment typically loses lint particles or fluff. The fluff is generally light and tiny, thus it can be brought out from the drum by the hot drying air flowing therein and then into the air circuit.

[0005] Once in the air circuit, the fluff is likely to accumulate therein, thereby possibly obstructing air ducts of the air circuit or negatively affecting the operation of one or more of its components (e.g., fluff may deposit on a fan, to the extent of possibly causing the latter to operate with a lower efficiency or completely stop it). In general, fluff accumulation has a detrimental effect on the laundry drying machine operation.

[0006] Therefore de-fluff filters have been designed for the purpose of retaining the fluff so as to prevent it from damaging the laundry machine components.

[0007] EP2471994 discloses a laundry drying appliance comprising a worktop with a filter.

[0008] For example, JP 2008/079855 discloses a drum type washing/drying machine that is provided with a filter chamber on which the filter for catching the foreign matters such as waste thread mainly is detachably mounted in the middle of a circulation air sending route for executing a laundry drying process by performing circulation through the circulation air sending route provided with a dehumidifying means and a heating means. The filter is in the double filter structure of a main filter functioning first to circulation air which enters from the circulation air introduction port of the filter chamber and is discharged from a circulation air discharge port and a backup filter

functioning after that. Since the backup filter is mounted before the main filter and is taken out after that and the main filter is mounted after the backup filter and is taken out before that, it is independently detached leaving the backup filter in the filter chamber to cope with the clogging treatment.

[0009] US 7,020,986 discloses a drum type washing and drying machine that includes a cylindrical rotary drum provided with multiple drum perforations on the cylindrical surface thereof and having a rotating shaft in a horizontal or a slanted direction, a water tub, supported in a main body of the machine, for accommodating the rotary drum therein; an air circulation channel for re-circulating air exhausted from the rotary drum back into the rotary drum via a dehumidification unit and a heating unit; and a lint trap device, installed in the air circulation channel, for filtering lint generated from laundry. The lint trap device at least includes a first and a second filter member capable of being detachably attached to each other, and the assembly of the first and the second filter member is freely attachably and detachably installed on a front upper portion of the main body in an approximately horizontal direction.

[0010] Nevertheless, the de-fluff filter needs to be periodically cleaned to avoid it to get clogged, event that may reduce the laundry machine efficiency or even cause a laundry drying machine malfunction, at least of the air circuit thereof. To this purpose, the de-fluff filter is usually removably accommodated in a filter seat within the air circuit, for example in a position located at the front of the casing in a top portion thereof, i.e. in position that are easily reachable by a user. Notwithstanding the presence of a well maintained de-fluff filter some fluff, particularly the smallest particles, are able to escape the de-fluff filter and accumulate in the air circuit.

[0011] The Applicant has tackled the problem of devising a laundry machine comprising a de-fluff filter arrangement comprising an auxiliary further de-fluff filter and a corresponding positioning thereof within the air circuit of the laundry machine adapted to improve the filtering efficiency of the drying process.

[0012] The Applicant has devised an auxiliary de-fluff filter that is easy to insert into, and to remove out of a corresponding housing, adapted to operate together with a (primary) de-fluff filter.

[0013] The present invention proposes a laundry machine as defined by claim 1 and adapted to dry laundry by means of a flow of drying air. The laundry machine comprises a casing for accommodating components necessary for the operation of the laundry machine. Inside the casing, a laundry treating chamber adapted to contain the laundry to be dried. A casing top element incorporating at least part of an air circuit in fluid communication with the laundry treating chamber through an inlet opening and through an outlet opening, and defining an air-path for the flow of drying air between said inlet and outlet openings. Said casing top element comprises a first filter housing for removably accommodating a first

de-fluff filter, said filter housing being provided in the air-path and being accessible through a housing aperture provided on the casing top element. The laundry machine further comprises a first de-fluff filter for trapping fluff or lint particles carried by the flow of drying air crossing said de-fluff filter, the first de-fluff filter comprising a filtering element and a hollow chamber accessible through an inlet aperture and through an outlet portion. In the solution according to an embodiment of the present invention, in the air-path for the flow of drying air defined by the casing top element, the laundry machine further comprises a second de-fluff filter removably received in a second filter housing.

[0014] Preferred features of the present invention are set in the dependent claims.

[0015] In an embodiment of the invention, the first and the second de-fluff filters are slidably coupled to the casing top element.

[0016] In the invention, the casing top element further comprises an inner panel and a base element, the inner panel being adapted to couple with at least a portion of the base element in such a way to define the air-path for the flow of drying, the first and second filter housings being provided between the inner panel and the base element.

[0017] In the invention, the second filter housing comprises a first groove provided in the inner panel and a second groove provided in the base element in such a way to be parallel and facing each other when the inner panel is coupled with the at least a portion of the base element, a distance between the first groove and the second groove is designed to substantially correspond to a cross-sectional height of the second de-fluff filter in such a way that the latter slidably fits the former.

[0018] In an embodiment of the invention, the first filter housing is accessible through a filter aperture which is delimited by a separating wall having a slot for inserting/extracting the second de-fluff filter in/from the second filter housing.

[0019] In the invention, the first de-fluff filter comprises an outlet portion, and wherein the second filter housing is provided facing said outlet portion when the first de-fluff filter is inserted in the first filter housing.

[0020] In an embodiment of the invention, the second filter housing defines a path which elastically deforms the second de-fluff filter when the latter is received/removed into/from said second filter housing.

[0021] In an embodiment of the invention, the first filter housing comprises an opened side having a frame that defines a plurality of side windows separated one from the other by separating elements, the second filter housing being provided adjacent to the opened side of the first filter housing.

[0022] In the invention, the second de-fluff filter is a strip-like element comprising a filtering portion adapted to filter the flow of drying air and a grasping portion adapted to be seized by a user during an insertion/extraction of the second de-fluff filter in/from the second filter hous-

ing.

[0023] In an embodiment of the invention, the grasping portion has a grip portion comprising a plurality of ribs formed transversally to an insertion/extraction direction of the second de-fluff filter in/from the second filter housing, and/or comprising a finger hole adapted to be hooked by a finger of a user.

[0024] In an embodiment of the invention, the first de-fluff filter comprises at least one filtering mesh, and the second de-fluff filter comprises at least one filtering mesh which is finer than the filtering mesh of the first de-fluff filter.

[0025] In an embodiment of the invention, the second de-fluff filter comprises a frame that encircles a filtering portion, which, in turn, comprises a plurality of filtering meshes, said frame having a plurality of mullion elements each mullion element dividing two adjacent filtering meshes from each other.

[0026] In an embodiment of the invention, each mesh of the second de-fluff filter is aligned with one of the plurality of side windows defined by the frame of the opened side of the first filter housing.

[0027] In an embodiment of the invention, the second de-fluff filter comprises an elastically deformable engagement element adapted to engage with a corresponding engagement portion provided on the second filter housing for holding the second de-fluff filter in place.

[0028] In an embodiment of the invention, the second de-fluff filter is made in resilient material so as to be elastically bent.

[0029] These, and others, features and advantages of the solution according to the present invention will be better understood with reference to the following detailed description of some embodiments thereof, provided for illustrative and not restrictive purposes, to be read in conjunction with the attached drawings. In this regard, it is expressly intended that the drawings are not necessarily to scale and that, unless specified otherwise, they simply aim to conceptually illustrate the structures and procedures. In particular:

Figure 1 is a perspective view of a laundry machine according to an embodiment of the present invention;

Figure 2A is a perspective view of the laundry machine of **Figure 1**, showing a top thereof in exploded view;

Figure 2B is a perspective view of a base element of the top of the laundry machine according to an embodiment of the present invention;

Figure 3A is a perspective exploded view of a de-fluff filter according to an embodiment of the present invention;

Figure 3B is a cross-sectional perspective view on **IIIB-IIIB** axis of a de-fluff filter according to an embodiment of the present invention comprising an enlarged view of a portion of a transversal sidewall thereof;

Figure 3C is a perspective view with removed parts of a de-fluff filter and of an inlet aperture of a de-fluff filter housing according to an embodiment of the present invention;

Figure 3D and **3E** are two cross-sectional side views on **IIIDE-IIIDE** axis of a rear portion of a de-fluff filter according to an embodiment of the present invention;

Figure 3F is a perspective view from below of a de-fluff filter according to an embodiment of the present invention;

Figure 3G and **3H** show two perspective views the de-fluff filter showing a lid thereof in a closed and in an opened position, respectively, with enlarged views highlighting features of the lid;

Figure 4A is a plan view of a top base element with a de-fluff filter inserted according to an embodiment of the present invention, featuring portions in transparency for highlighting mechanical interaction between the two;

Figure 4B is a plan view of the top base element of **Figure 4A** with the de-fluff filter in a released condition;

Figure 5A is a perspective view of an auxiliary de-fluff filter according to an embodiment of the present invention;

Figure 5B is a cross-sectional view of a portion of an air circuit of a laundry machine along a **V-V** axis in which housing grooves accommodate the auxiliary de-fluff filter of **Figure 5A**, and

Figure 5C is a cutaway and exploded view of the portion of the air circuit comprising the housing grooves and the auxiliary de-fluff filter.

[0030] With reference to the drawings, **Figure 1** is a perspective view of a laundry machine, globally denoted as **100**, according to an embodiment of the present invention.

[0031] The laundry machine **100** comprises a laundry treatment chamber **105** for accommodating the items to be dried or washed and dried, such as clothes, garments, linen, and similar laundry items. Preferably, the laundry treatment chamber **105** includes a drum (not shown) rotatably mounted inside a machine cabinet or casing **110**, and in case the laundry machine **100** is a washing/drying laundry machine the drum is arranged within a tub (not shown) housed in the machine casing or cabinet **110**.

[0032] The casing **110** generally accommodates all the electrical, electronic, mechanical, and hydraulic components necessary for the operation of the laundry machine. The casing **110** has generically a parallelepiped shape, with a front wall **115**, two side walls **120** (only one visible in **Figure 1**), a rear wall (not visible), a basement and a top element, or simply top **125**. The front wall **115** is provided with an opening for accessing the drum and with an associated door **117** for closing the opening. In the upper part of the front wall **115**, a machine control panel **130** is located, and, aside the control panel **130**, a drawer

135 is provided, which is part of a washing treatment products dispensing arrangement, for loading laundry washing treatment products like detergents and softeners. The top **125** closes the casing **110** from above, and defines a worktop.

[0033] In one embodiment of the invention, a de-fluff filter (aesthetic) cover **140** is exposed on the control panel **130** on the front wall **115**, e.g. above the drawer **135**, and flush therewith. Preferably, the de-fluff filter cover **140** may comprise a pushbutton portion **145** (which purpose will be described in the following).

[0034] Reference is now made to **Figures 2A-2B**, which are a perspective view of the laundry machine **100** with its top **125** in exploded view and a perspective view of a base element **205** of the top **125** with some parts removed.

[0035] In one embodiment of the invention, the top **125** integrates part of an air circuit adapted to circulate drying air across the laundry treating chamber **105** for drying the laundry stored therein (as described in greater detail below).

[0036] The top **125** comprises the base element **205**, which has an inlet opening **210** and an outlet opening **215**, the inlet opening **210** being in fluid communication with the laundry treatment chamber **105** through a chamber outlet, the outlet opening **215** being in fluid communication with a fan arrangement **216**.

[0037] The fan arrangement **216** comprises a fan and a corresponding fan duct, the fan produces the drying air flow inside the air circuit by sucking drying air from the outlet opening **215** and blowing the drying air into the laundry treatment chamber **105**, the outlet opening **215** and the laundry treatment chamber **105** being both fluidly connected to the fan arrangement **216**.

[0038] In the region of the base element **205**, preferably near the front-left corner thereof, a filter housing **217** is provided suitable to house a de-fluff filter **218** (described in greater detail below). Preferably, the filter housing **217** has roughly a right trapezoid outline in plan view (e.g., similar to a grand piano), with a shorter sidewall **217a** (corresponding to a lesser base of the right trapezoid) in fluid communication with the chamber outlet by means of the inlet opening **210**, and a larger sidewall **217b** (opposite to the shorter sidewall **217a**, and corresponding to a greater base of the right trapezoid) that has a housing aperture **219** opened on the machine front wall **115** preferably in a separating wall **205a** (visible in **Figure 5C**) of the base element **205**, preferably in a portion adjacent to the control panel **130**, even more preferably above the drawer **135** for allowing the insertion of the de-fluff filter **218**. Moreover, the filter housing **217** comprises a right sidewall **217c** substantially corresponding to a portion of a lateral sidewall of the base element **205** of the top **125** (and corresponding to the right leg of the right trapezoid) and a transversal opened side **217d**, preferably inclined (opposite to the right sidewall **217c** and corresponding to the inclined leg of the right trapezoid).

[0039] In one embodiment of the present invention, the inlet opening **210** is fluidly connected to an adapter element **212**, which is provided to fluidly connect the inlet opening **210** with the filter housing **217** and the de-fluff filter **218** (when inserted in the filter housing **217**). Preferably, but not limitatively, the adapter element **212** may be a parallelepiped-shape element adapted to be coupled to the base element **205**, with conical or cylindrical passage(s) provided therein with two opposite apertures to fluidly connect the inlet opening **210** with the de-fluff filter **218**. The adapter element **212** may be made of any suitable material, e.g. a polymeric material, and is coupled to the base element **205** by means of any suitable coupling arrangement, e.g. by tightly fitting a rear portion of the filter housing **217** (adjacent to the shorter sidewall **217a**).

[0040] In a preferred embodiment of the invention, the aperture facing the filter housing **217** of the adapter element **212** is surrounded by a gasket element **212a** which protrudes towards the inside of the filter housing **217**. In alternative embodiments of the present invention in which the adapter element **212** is not provided, an alternative gasket element may be directly provided around the inlet opening **210**.

[0041] In one embodiment of the present invention, the transversal opened side **217d** comprises a frame **220** that defines a plurality of side windows **220a** separated one from the other by separating elements, such as for example mullion elements **220b**, preferably prism-shaped. Preferably, at the frame **220** housing grooves (not shown in **Figures 2A** and **2B**, but visible in **Figure 5B** where are denoted with the references **505u** and **505l**) adapted to house an auxiliary filter **221** (described in detail in the following) are provided. Advantageously, a plurality of flap elements **222** may be provided. The flap elements **222** protrude from the frame **220** opposite to the filter housing **217** in order to direct the drying air flow exiting the transversal opened side **217d** towards the rest of the air circuit defined in the top **125**.

[0042] In the central region of the base element **205**, there is accommodated a first heat-exchanging unit, such as a moisture condensing element **225**, for example comprising an evaporator of a heat pump apparatus. The moisture condensing element **225** is adjacent to the transversal opened side **217d**, and thus the external surface of the former is in fluid communication with the latter. Next to the moisture condensing element **225**, opposite to the filter housing **217**, there is provided a second heat-exchanging unit, such as a drying air heating element **230**, for example comprising a condenser of the heat pump apparatus. The moisture condensing element **225** has the function of dehydrating the drying air, by cooling it down; the drying air heating element **230** has instead the function of heating the dehydrated drying air. A compressor (not shown) for the heat pump may be attached to the base element **205** in correspondence of the front-right corner thereof, the body of the compressor protruding from below the base element **205**. In an alternative

embodiment, the compressor may be located in the bottom of the casing **110**, attached to the basement of the laundry machine **100**, and be fluidly connected to the moisture condensing element **225** accommodated in the top **125** by means of flexible pipes that preferably run along a rear corner of the casing **110** or along the laundry treatment chamber **105** of the laundry machine **100**. In a different embodiment of the present invention, the laundry machine **100** may comprise an air-air or an air-water heat exchanger apparatus and an electric heater instead of the heat pump apparatus.

[0043] The base element **205** of the top **125** is covered by an inner panel **235**, that covers essentially the moisture condensing element **225**, the drying air heating element **230** and the de-fluff filter **218**. The top **125** is completed by an outer (aesthetic) panel **240**. The base element **205** and the inner panel **235** define an air-path that conveys the moisture-laden air coming from the laundry treatment chamber **105** (through the inlet opening **210**) towards the de-fluff filter **218**, preventing the moisture-laden air from entering directly the moisture condensing element **225** or the drying air heating element **230** (i.e., before being filtered by the de-fluff filter **217**), and then the drying air flow follows the air-path from the de-fluff filter **218** to the heating element **230**, passing through the moisture condensing element **225**, and eventually reaching the outlet opening **215**.

[0044] Preferably, the top **125**, once assembled, forms a unit that is ready to be mounted to the casing **110**, simply by placing it in the correct alignment, so that the openings **210** and **215** matches the chamber outlet and an intake of the fan arrangement **216**, respectively, thus realizing a closed air circuit comprising the laundry treatment chamber **105** and the air-path defined by the base element **205** and the inner panel **235**, and the fan arrangement **216**. The top **125** may then be secured to the casing **110** by conventional means (e.g., by means of gluing, screwing or other connecting means).

[0045] In the laundry machine **100**, when operated in dryer mode (i.e., for drying items stored in the drum), drying air (i.e., warm and dry air) is typically caused to flow through the drum **105** inside the laundry treating chamber **105**, where the items to be dried are contained. The drying air binds to moisture particles from the laundry and/or dispersed within the laundry treating chamber **105** and carries them away. The drying air may also carry away fluff (e.g., generated from the laundry during laundry treating processes) from the laundry together with moisture particles. After exiting the drum through the chamber outlet, the flow of now moisture-laden drying air passes through the de-fluff filter **218** where substantially any fluff carried by the drying air flow together with moisture particles is caught and remains trapped. Instead, the moisture-laden drying air is conveyed towards the moisture condensing element **225**, where the moisture-laden drying air is at least partially dried, i.e. dehydrated, and such dehydrated drying air flow is then heated by the air heating element **230** through which the drying air flows,

which heats the drying air up to a drying temperature (e.g., set by a user through the control panel **130** via the selection of a drying program). Then the drying air is sucked by the fan through the fan intake and is caused to pass again through the drum **105** drying the laundry therein stored and then repeating the cycle just described.

[0046] Considering now **Figures 3A-3H**, they are different views of the de-fluff filter **218** according to embodiments of the present invention.

[0047] The de-fluff filter **218** is designed to be inserted inside the filter housing **217** preferably through the housing aperture **219** exposed on the front wall **115**. Preferably, the de-fluff filter **218** is designed such as an extractable drawer.

[0048] The de-fluff filter **218** comprises a filter box **303**, a cover element, such as for example a lid **306**, and in addition it may preferably comprise a closing element, such as a swinging bulkhead **309**, an ejection device **312**, and a locking element **315**.

[0049] The filter box **303** has a parallelepiped shape, preferably with a roughly rectangular trapezoid base. For example, the filter box **303** of the filter housing **217** may have a shape similar to that of a grand piano, with a rear sidewall **303a**, a front sidewall **303b**, a first transversal sidewall **303c**, a second transversal sidewall **303d**, preferably curved, and a bottom wall **303e**. The sidewalls **303a**, **303b**, **303c**, **303d** delimit a top aperture **303t** of the filter box **303**. The filter box **303** may be made in any suitable material, such as for example a suitable polymer (e.g., Polypropylene PP).

[0050] Preferably (as can be appreciated in **Figure 2B**), the filter box **303** is designed in such a way that, once the de-fluff filter **218** is inserted into the filter housing **217**, the former substantially tightly fits the latter. Even more preferably, the sidewalls **303a** and **303c** are adapted to substantially flank the sidewalls **217a** and **217c**, respectively, of the filter housing **217** and may contact them, while the front sidewall **303b** substantially closes the housing aperture **219** and the second transversal sidewall **303d** faces the transversal opened side **217d** of the filter housing **217**, preferably remaining separated therefrom.

[0051] Preferably, the filter box **303** is designed in such a way that its second transversal sidewall **303d** remains spaced apart from the transversal opened side **217d** of the filter housing **217**, thus defining a gap between the second transversal sidewall **303d** and the transversal opened side **217d**.

[0052] The second transversal sidewall **303d** operates substantially as a filtering portion and as an outlet portion of the de-fluff filter **218**. The second transversal sidewall **303d** comprises a frame **318** that encloses a plurality of windows **318a** separated from each other by separating elements, such as for example box mullion elements **318b**, preferably parallelepiped shaped. The box mullion elements **318b** extend from a lower portion of the frame **318** (at the bottom wall **303b**) of the filter box **303** up to

a higher portion of the frame **318** (at the top aperture **303t**). Advantageously, the box mullion elements **318b** are designed to align with the mullion elements **220b** of the transversal opened side **217d** (once the de-fluff filter **305** is inserted into the filter housing **217**), in such a way to not to hinder the drying air flow.

[0053] The filter box **303** further comprises a filtering element, such as for example a filtering mesh **321** preferably rectangular and is sized with a length and a height substantially equal to a length and a height of the second transversal sidewall **303d**. The filtering mesh **321** is coupled to the second transversal sidewall **303d** covering the apertures of the windows **318a** in such a way to filter the drying air flow passing therethrough (as will be described in greater detail in the following). The filtering mesh **321** is preferably coupled to the second transversal sidewall **303d** on an internal face thereof (i.e., facing the inside of the filter box **303**). The filtering mesh **321** may be made in any suitable material, such as for example a suitable polymer (e.g., Polyethersulfone or "PES") that may be over-injected onto the internal face of the second transversal sidewall **303d**. Alternatively, the filtering mesh **321** may be attached to the frame **318** of the second transversal sidewall **303d** in any other suitable manner (e.g., by gluing together the filtering mesh **321** and the second transversal sidewall **303d**) or, conversely, may be removably coupled with the frame **318** (e.g., by providing suitable snap-fit engage elements). Alternatively, a plurality of smaller filtering meshes may be provided each one adapted to be coupled to a respective window **318a**.

[0054] It should be noted that the mullion elements **318b**, along enhancing the structural strength of the frame **318** also enhance a robustness the filtering mesh **321** preventing deformation of the filtering mesh **321** that the air flow may provoke, e.g. a bending of the central portion of the filtering mesh **321** in the direction of the flow of air that could cause a concentration of trapped fluff in such bent central portion.

[0055] The filter box **303** preferably also comprises a cover support **324** attached to (or, alternatively, formed integral with) the front sidewall **303b**. The cover support **324** is designed to protrude outwards from the aperture **219** in the larger sidewall **217b** in order to support the de-fluff filter cover **140** (when the de-fluff filter **218** is inserted into the filter housing **217**). Preferably, the cover support **324** comprises a tab **327** protruding substantially transversal to the front sidewall **303b** towards the rear sidewall **303a** on an end the cover support **324**. For example, the de-fluff filter cover **140** may be coupled to the cover support **324** by means of one or more snap-fit elements (not shown), each fitting a corresponding coupling element, such as holes **324a**, provided on the cover support element **324**. In other embodiments according to the present invention, a tab may be placed in a different position and/or more than just a tab may be provided.

[0056] The cover support **324**, the front sidewall **303b** and/or the de-fluff filter cover **140** may be either formed

as different elements that can be engaged one another in any suitable known manner, or as a one-piece element. **[0057]** In alternative embodiments of the present invention, an alternative cover element may be provided featuring a grasping element (such as for example a handle).

[0058] The rear sidewall **303a** of the filter box **303** comprises an inlet aperture **330** which is adapted to receive the drying air flow coming from the laundry treatment chamber **105** through the inlet opening **210** in the shorter sidewall **217a**. Preferably the outlet portion, i.e. the second transversal sidewall **303d**, has a greater extension than the inlet aperture **330**, such that the filtering mesh **321** arranged on the outlet portion **303d** may have a wide extension. Preferably, the rear sidewall **303a** is also provided with a protruding frame **333** that surrounds the inlet aperture **330** and protrudes from a border of the filter box **303** surrounding the inlet aperture **330** towards the outside of the filter box **303**. The protruding frame **333** is adapted to engage with the gasket element **212a** of the adapter element **212** preferably in an airtight manner (thus fluidly connecting the de-fluff filter **218** with inlet opening **210**).

[0059] Advantageously, the swinging bulkhead **309** is provided at the inlet aperture **330**. The swinging bulkhead **309** has a shape, e.g. substantially rectangular, adapted to close, preferably seal, the inlet aperture **330**. The swinging bulkhead **309** is designed to have a weight such that a kinetic force of the drying air flow (schematically represented by an arrow in **Figure 3E**) from the laundry treatment chamber **105** is able to swing the bulkhead towards inside of the filter box **303** (thus, clearing the inlet aperture **330**). The swinging bulkhead **309** may be made in any suitable material, e.g. a polymer.

[0060] Preferably, the swinging bulkhead **309** is hinged to the first transversal sidewall **303c** and to the second transversal sidewall **303d** close to the rear sidewall **303a**. For example, the swinging bulkhead **309** may be provided with two protruding pins **309a** on opposite shortest sides (at top corners thereof), which are adapted to be inserted into two matching rear bores **336**, a first one provided in the first transversal sidewall **303c** and a second one provided in the second transversal sidewall **303d**. Preferably, at the inlet aperture **330** an abutment element **330a** is provided that is adapted to prevent the swinging bulkhead **309** from swinging towards the outside of the filter box **303** (i.e., the swinging bulkhead **309** is allowed to swing only towards the inside of the filter box **303**). Thanks to the swinging bulkhead **309** and the abutment element **330a** it is possible to prevent, or substantially reducing, any spurious flow of air from the de-fluff filter **218** towards the inlet opening **210** (i.e., opposite to the direction desired for the flow of drying air).

[0061] Preferably, in the bottom wall **303e** a niche **339** is formed. The niche **339** extends inwards into the filter box **303**. The niche **339** comprises a side opening **339a** on the transversal wall **303c** and is preferably located close to the front wall **303b**. Inside the niche **339**, a first

rail element **339b** preferably protrudes from a bottom wall thereof (e.g. in a central position), parallel to the transversal wall **303c**. Moreover, engagement elements, such as snap-fit elements **339c**, protrude from sidewalls of the niche **339**, preferably with the exception of the sidewall where the side opening **339a** is formed.

[0062] The niche **339** is adapted to house the ejection device **312** that allows ejecting the de-fluff filter **218** from its housing **217** (as described in the following). The ejection device **312** allows the de-fluff filter **218** to be at least slightly ejected from the filter housing **217** so as to be easily grasped by a user.

[0063] In one embodiment of the present invention, the ejection device **312** comprises a substantially box-like container **312a**, with a major side opened and a (long) lateral side lower than the others. The box-like container **312a** houses a pushing element **342** adapted to engage with a matching engaging element provided in the right sidewall **217c** (not shown in **Figures 3A-3H**, but visible in **Figures 4A** and **4B** wherein is denoted with the reference **410**) in order to block the de-fluff filter **218** in an operating position (as described in the following).

[0064] For example, the pushing element **342** comprises an engaging head **345** and a biasing element **348** (such as for example a coil spring), with the engaging head **345** that has a portion partly protruding outwards the box-like container **312a** (through the lowest lateral side mentioned above) and also protruding outwardly from the side opening **339a**, once the ejection device is inserted into the niche **339**. The engaging head **345** is coupled to a biasing element **348**, for example a coil spring, at one end of the latter, while an opposite end of the biasing element **348** contacts a (short) lateral side of the box-like container **312a**.

[0065] Moreover, the ejection device **312** may comprise a second rail element **312b** (provided in a bottom wall of the box-like container **312a**) and engage elements, such as matching snap-fit elements **312c** (provided in lateral sides of the box-like container **312a**) adapted to match the snap-fit elements **339c**, (if provided in the niche **339**). Advantageously, the first and second rail elements **339b** and **312b** are adapted to guide a sliding of the engaging head **345**, which comprises rail slots **345a** adapted to be fitted by the rail elements **339b** and **312b**, and guide slots **345b** adapted to be fitted by a border on the opened side of the box-like container **312a** of the ejection device **312** and by a border of the side opening **339a** of the niche **339**, in order to guide (longitudinally) the movements of the engaging head **345** when the latter is biased by the biasing element **348**, or the whole de-fluff filter **217** is moved against such biasing (as will be described in the following).

[0066] The locking element **315** is adapted to maintain the de-fluff filter **218** in the operating position once inserted into the filter housing **217**.

[0067] For example, the locking element **315** is substantially an "L"-shaped lever that comprises a push portion **315a** and a nose portion **315b** substantially trans-

versal to the former. The push portion **315a** is preferably parallelepiped-shaped, while the nose portion **315b** is substantially a stick element comprising a nose element **351**. The nose element **351** protrudes transversal to the nose portion **315b**, and is preferably positioned at a free end of the nose portion **315b** opposite to an intersection the two portions **315a** and **315b**. The nose element **351** comprises a blocking element **351a**, with preferably, a cylindrical shape with an inclined top surface (inclined with a higher edge facing towards the cover support **324** and a lower edge facing towards the filter box **303** when the locking element **315** is coupled with the cover support **324**) and one or more sliding elements **351b** such as for example two ribs having a right triangle shape with the right angle thereof adjacent to the blocking element **351a**.

[0068] At the intersection between the two portions **315a** and **315b** two pins **315c** protrude in opposite directions from the locking element **315** substantially transversal to both the portions **315a** and **315b**. The locking element **315** is preferably hinged to the cover support **324** by means of the pins **315c** which are inserted into corresponding pinholes **324b** provided in opposite position on the cover support **324**. In such a hinged position, the nose element **351** is exposed from a nose window **324b** provided in a lower portion the cover support **324**. The locking element **315** also comprises a biasing element, such as a coil spring **315d**, which is coupled to the push portion **315a** (at a rear side thereof) at one of its ends, and contact a recessed wall **324d** of the cover support **324** at the opposite end.

[0069] In an inner portion of the filter box **303** a guiding wall **354** may be preferably provided in order to guide the drying air flow from the inlet aperture **330** to the second transversal sidewall **303d**. For example, the guiding wall **354** may be a curved wall connecting the first transversal sidewall **303c** with an end of the second transversal sidewall **303d** adjacent to the front sidewall **303b**. Generally, the guiding wall **354** is designed in such a way to provide the best fluid-dynamic behaviour for the drying air flow inside the de-fluff filter box **218** (e.g., adapted to effectively direct the drying air flow homogeneously towards the whole second transversal sidewall **303d** generating the lowest turbulence in the drying air flow as possible).

[0070] The top aperture **303t** of the filter box **303** is closed by the lid **306**, preferably in an airtight manner. The lid **306** may be preferably made of a suitable polymer.

[0071] More preferably the lid **306** is made of a bi-component plastic using over-injection technology. For example, a lid frame **357**, preferably comprising peripheral portion **357a** and internal (reinforcing) ribs **357b**, may be made of Acrylonitrile Butadiene Styrene (ABS). Conversely, transparent panes **360** provided enclosed by the lid frame **357**, preferably with each transparent pane **360** provided in position delimited by ribs **357b** and/or the peripheral portion **357a** of the lid frame **357**, may be made of Polycarbonate (PC). The transparent panes **360** allow a user to verify the presence, and the quantity, of fluff trapped inside the filter box **303** without the need of open-

ing it.

[0072] On the lid frame **357**, a sealing border **357c** is preferably provided. The sealing border **357c** protrudes from the lid frame **357** from a lower side thereof (i.e., towards the inside of the filter box **303** when the lid **306** closes the top aperture **303t** of the latter), and preferably along positions of the lid frame **357** that corresponds to the rear sidewall **303a**, the second transversal sidewall **303d**, the guiding wall **354** and a portion of the first transversal sidewall **303c** of the filter box **303**, in such a way to be contained inside the filter box **303** once the lid **306** is coupled with the former. Preferably, the lid borders mentioned above, the sealing border **357c** and the top portion of the sidewalls **303a**, **303c**, and **303d** are adapted to hinder the passage to fluff by forming a meandering path (as can be appreciated in the enlargement of **Figure 3B**). Even more preferably, the sealing border **357c** and the top portion of the sidewalls **303a**, **303c**, and **303d** are designed in such a way to couple together by a snap-fit engagement. The sealing border **357c** is designed to substantially seal the top aperture **303t** of the filter box **303**, when in a closed position, thus allowing air entering and/or exiting a hollow chamber **361** within the de-fluff filter **218** (i.e., defined by the filter box **303** and the lid **306** in closed position in which trapped fluff remains confined) only through the inlet aperture **330** and the windows **318a** in the second transversal sidewall **303d**.

[0073] In one embodiment of the present invention, the sealing border **357c** may also be provided with a gasket in order to obtain an improved airtight coupling with the filter box **303**.

[0074] In order to allow a user easily opening (i.e., decouple) the lid **306** from the filter box **303**, one or more grasping portions may be provided, such as for example one or more opening flaps **357d**, preferably at ends of the peripheral portion **357a** of the lid frame **357** corresponding to the first transversal sidewall **303c** and the second transversal sidewall **303d** in the proximity of the rear sidewall **303a** of the filter box **303**.

[0075] In an embodiment of the invention, the lid **306** comprises one or more (air) guiding blades **363** (three in the figures) protruding from a lower side of the lid **306** (i.e., towards the inside of the filter box **303** when the lid **306** closes the top aperture **303t**). Preferably, the guiding blades **363** are provided in positions corresponding to the ribs **357b** and made in the same material of the lid frame **357** and, even more preferably, integral with the latter (thus obtaining a mechanically robust structure).

[0076] The guiding blades **363** are, preferably, designed in such a way to reach the bottom wall **303e** of the filter box **303**, when the lid **306** closes the top aperture **303t**, thus substantially subdividing the hollow chamber **361** of the filter box **303** in sub-chambers, having preferably a sectional area that increases along the drying air flow direction path, in such a way to distribute substantially evenly the drying air flow inside the filter box **303**, and have a preferably curved shaped to provide the best fluid-dynamic behaviour for the drying air flow thus

homogeneously directing the drying air flow towards the filtering mesh **321** and avoiding localized fluff accumulations and consequent localized occlusions thereof.

[0077] Preferably, the guiding blades **363** are designed in such a way to be aligned with the mullion elements **318b** of the frame **318**, thus avoiding to hinder the drying air flow passing through the de-fluff filter **218**.

[0078] In other embodiments of the present invention, alternative guiding blades may be provided protruding from the bottom wall of the filter box instead from the lid.

[0079] In order to be pivotally coupled to the filter box **303**, the lid **306** comprises a couple of hinges **366**, preferably protruding substantially at opposite ends of a front side of the lid **306** (i.e., corresponding to the front sidewall **303b** of the filter box **303**). Each hinge **366** protrudes from the lid frame **357** transversally thereto and has a pin **366a** in its turn protruding from the center of a flat portion **366b** transversally thereto, with the flat portion **366b** that is preferably substantially circular.

[0080] Each pin **366a** is adapted to engage a matching front bore **369** provided on the first transversal sidewall **303c** and on the second transversal sidewall **303d** in a location adjacent to the front sidewall **303b**. Each flat portion **366b** is provided with a couple of notches **366c** separated by a substantially 90° angle (even though greater or smaller angles are not excluded) along the periphery of the flat portion **366b**, and adapted to engage a corresponding bump **371** provided in a recessed portion of the first transversal sidewall **303c** and of the second transversal sidewall **303d** close to the front sidewall **303b**. Preferably, a first one of the notches **366c** and the pin **366a** define a line substantially parallel to the peripheral portion **357a** of the lid frame **357**, while a second one of the notches **366c** define with the same pin **366a** a line substantially transversal to the peripheral portion **357a** of the lid frame **357**.

[0081] The engagement between the bumps **371** and the notches **366c** substantially parallel to the lid **306** defines a closed position in which the lid **306** closes the top aperture **303t**, while the engagement between the bumps **371** and the notches **366c** substantially transversal to the lid **306** defines an opened position in which the lid **306** is transversal to the top aperture **303t**.

[0082] Having outlined the structures of the top **125** of the laundry machine **100** and the de-fluff filter **218**, the insertion and the removal the de-fluff filter **218** from its housing **217** are now described, by making reference to the **Figures 4A** and **4B** that are top views with removed parts of the base element **205** of the top **125** with the de-fluff filter **218** shown in an inserted position and in a released position inside the filter housing **217**, respectively.

[0083] As mentioned above, the de-fluff filter **218** is inserted into the filter housing **217** through the housing aperture **219** with the rear sidewall **303a** of the filter box **303** first, and with the lid **306** in the closed position. During the insertion of the de-fluff filter **218**, the engaging head **345** intercepts and engages the matching engaging element **410** formed in the right sidewall **217c** of the filter

housing **217**. The engaging head **345** remains substantially blocked in a position abutting the matching engaging element **410**, while the de-fluff filter **218** is further inserted into the filter housing **217**. Thanks to such an abutment, the biasing spring **348** is compressed (i.e., switches from an elongated condition to a shrunk condition accumulating potential energy). It should be apparent to those skilled in the art that the rail elements **339b** and **312b** maintain the engaging head **345** in correct position, i.e. preventing any torsion thereof due to the lateral abutment with the matching engaging element **410** combined with the increasing compression provided by the insertion of the de-fluff filter **218** into the filter housing **217**.

[0084] Once the insertion of the de-fluff filter **218** in the filter housing **217** is completed, the protruding frame **333** (protruding from the inlet aperture **330** of the filter box **318**) engages the gasket element **210a** obtaining a substantially airtight fluid connection with the inlet opening **210** of the filter housing **217**. Substantially at the same time, the nose element **351** engages with a lower border of a nose slot **420** formed in the base element **205** close to the aperture **219**. The nose element **351** engaging the lower border of the nose slot **420** prevents the biasing element **348** of the ejection device **312** from extending back into the elongated condition, thus maintaining the de-fluff filter **218** in the inserted position inside the filter housing **217**.

[0085] In order to prevent incorrect insertions in the filter housing **217** of the de-fluff filter **218**, the de-fluff filter **218** can preferably be inserted in the filter housing **217** only if the tab **327** is inserted inside a tab slot **425** that is provided on the separating wall **205a** of the base element **205**, which substantially separates the control panel **130** from the inner portion of the top **125**, preferably in a position close to the aperture **219**.

[0086] A user can easily unlock the de-fluff filter **218** from its housing **217** simply by pressing the pushbutton portion **145** of the aesthetic cover **140** of the de-fluff filter **218**.

[0087] The pushbutton portion **145** is provided with an appendage **435** (even though more appendages may be provided as well) that contacts the push portion **315a** of the locking element **315**. Therefore, by pushing the pushbutton portion **145** the pushing action is transferred to the push portion **315a**, which causes the locking element **315** to pivot about the axis defined by its two pins **315c**. This pivoting makes the sliding elements **351b** intercept the lower border (i.e., the more external border) of the nose slot **420** with their inclined edges deforming in a non-permanent manner the nose portion **315b**. Such deformation disengages the blocking element **351a** of the nose element **351** from the nose slot **420**, which in its turns allows the biasing element **348** of the pushing element **342** to extend in the elongated condition (thus releasing the stored potential energy as a kinetic force). The extension of the biasing element **348**, with the engaging head **345** still abutting the matching engaging element **410**, provokes the de-fluff filter **218** to slide out

from the filter housing **217** through the aperture **219** for a releasing length substantially corresponding to the difference between the length of the biasing element **348** in the rest condition and the length of the biasing element **348** in the compressed condition (such release length is advantageously designed in such a way to allow an easy grasping of the de-fluff filter **218** by a user). It should be noted that the sliding of the de-fluff filter **218** out from the filter housing **217** is substantially rectilinear thanks to the rails **339b** and **312b** which prevents the lateral swaying of the de-fluff filter **218**.

[0088] The de-fluff filter **218** according to the present invention is thus adapted to be easily positioned and removed inside its filter housing **217**.

[0089] Particularly, the ejection device **312**, the locking device **315** and the tab **327** provide a simple and efficient arrangement that ensure a correct insertion in operating position of the de-fluff filter **218** inside the filter housing **217** (with substantially no air leakages inside the top **125**). This ensures that the correct insertion of the de-fluff filter **218** completes the air-path for the drying air, since the de-fluff filter **218** forms a fundamental portion thereof. Indeed, the de-fluff filter **218** along with trapping the fluff carried by the drying air flow, particularly thanks to the guiding wall **354** and the blades **363**, directs the drying air flow towards the moisture condensing unit **225** with a minimal generation of turbulences and with a homogeneous distribution thereof along the whole length of the transversal opened side **274d**, thus improving the heat exchanging operation of the heat exchanger **225** and **230**.

[0090] Moreover, the ejection device **312** and the locking device **315** according to the present invention allow an effortless releasing the de-fluff filter **218** for the user (it is just needed to push the pushbutton **145** and then manually complete the extraction of the de-fluff filter **218**). Such effortless releasing together with the transparent panes **360** and with the positioning the de-fluff filter **218** within the top **125** of the laundry machine **100**, greatly simplify the de-fluff filter **218** inspection and cleaning by a user lowering the chance of a clogging the de-fluff filter **218** due to lack of maintenance and a consequent reduction of efficiency of the drying air circuit.

[0091] The auxiliary de-fluff filter **221** and its housing arrangement are now described by making reference to **Figures 5A - 5C**, which show a perspective view of the auxiliary de-fluff filter **221** and a cross-sectional view along the **V-V** axis of the transversal opened side **217d** with the auxiliary de-fluff filter **221** inserted in corresponding housing grooves **505u** and **505l**, and a cutaway and exploded view of such housing grooves **505u**, **505l** and of the auxiliary de-fluff filter **221**, respectively.

[0092] The auxiliary de-fluff filter **221** is substantially a strip-like element that comprises a filtering portion **510f** and a grasping portion **510g**. Preferably, the filtering portion **510f** and the grasping portion **510g** are made in one piece of any suitable material, such as a resilient polymer.

[0093] The filtering portion **510f** comprises a frame **515**

that encircles at least one, but preferably a plurality of filtering meshes **520** separated by auxiliary mullion elements **525** (i.e., each auxiliary mullion element **525** divides two corresponding adjacent filtering meshes **520** between which the auxiliary mullion element **525** is provided). Preferably, the filtering meshes **520** are narrower (i.e., finer) than the filtering mesh **321** of the de-fluff filter **218** is, in order to trap small fluff particles escaped from the latter.

[0094] Also in this case, the auxiliary mullion elements **525**, bestow an enhanced robustness to each one of the plurality filtering meshes **520** preventing deformation of the filtering meshes **520** that the air flow may provoke.

[0095] The grasping portion **510g** is provided at one end of the auxiliary de-fluff filter **221** and comprises a grip portion **530** preferably adapted to be firmly gripped with only two fingers by a user, e.g. the grip portion **530** comprises a plurality of ribs **535** preferably formed transversal to a largest side of the auxiliary de-fluff filter **221** for enhancing a grip from the user. The grasping portion **510g** also comprises a finger hole **540** adapted to be hooked by a finger of a user in order to more easily extract the auxiliary de-fluff filter **221** from the top **125** of the laundry machine **100**.

[0096] At the border between the grasping portion **510g** and the filtering portion **510f**, at opposite positions on a rim **550** of the frame **515** of the auxiliary de-fluff filter **221** at least two elastic engagement element **545** are preferably provided. Preferably, each elastic engagement element **545** substantially comprises a bump **545a** protruding outwardly from the rim **550** of the auxiliary de-fluff filter **221** and an eyelet **545b** just beneath the bump **545a**.

[0097] In one embodiment of the invention, the auxiliary de-fluff filter **221** can be easily made to slide into a path defined by housing grooves **505u** and **505l** by a user. The auxiliary de-fluff filter **221** is inserted inside the top **125** through an auxiliary slot **555** positioned adjacent to (preferably between) the housing aperture **219** and the tab slot **425** in the front sidewall **205b** of the base element **205**, for example by a user holding the auxiliary de-fluff filter **221** by its grasping portion **510g**. Preferably the auxiliary slot **555** is positioned in such a way to be hidden by the cover element **140** when the de-fluff filter **218** is inserted in the filter housing **217**.

[0098] The housing grooves **505u** and **505l** runs in the inner panel **235** and in the base element **205**, respectively, parallel and opposite to each other (when the inner panel **235** covers the base element **205**), and preferably adjacent to the frame **220** of the transversal opened side **217d** of the filter housing **217**. A distance between the housing grooves **505u** and **505l** is designed to substantially correspond to the cross-sectional height of the auxiliary de-fluff filter **221**, in such a way that the latter slidably fits the former (as can be appreciated in **Figure 5B**).

[0099] The auxiliary de-fluff filter **221** is inserted inside the top **125** through the auxiliary slot **555** positioned adjacent to the housing aperture **219** until the bumps **545a**

trespass corresponding engagement portions (not shown) protruding from the housing grooves **505u** and **505l** in opposite positions (e.g., towards each other). When pressed against the engagement portions, the bumps **545a** of the two elastic engagement elements **545** are deformed, i.e. the bumps **545a** bend inwards closing the respective eyelet **545b**, thus the elastic engagement elements **545** trespass the engagement portions and the auxiliary de-fluff filter **221** reach a working position. In the engaged position the bumps **545a** may return in their normal (i.e., protruding) configuration abutting against the engagement portions, thus securing the auxiliary de-fluff filter **221** in its working position, i.e. completely inserted in the housing path defined by housing grooves **505u** and **505l** (even though embodiments of the present invention featuring bumps that remains compressed when the auxiliary de-fluff filter is in its working position are not excluded). It should be noted that the auxiliary de-fluff filter **221** follows the bend defined by the housing grooves **505u** and **505l** (which substantially corresponds to a bend of the transversal opened side **217d**, as can be appreciated in the exploded view of **Figure 5C**) thanks to its resiliency.

[0100] Advantageously, a sidewall **560** of the auxiliary slot **555**, preferably the sidewall separating the auxiliary slot **555** from the housing aperture **219**, is provided with an aperture **560a** extending towards the inside of the filter housing **217** from the auxiliary slot **555**. The aperture **560a** allows the user easily and completely fitting the auxiliary de-fluff filter **221** in the path defined by housing grooves **505u** and **505l**, since the grasping portion **510g** may be hold by the user (through the aperture **560a**) until the auxiliary de-fluff filter **221** is brought in its working position.

[0101] During the laundry machine **100** operation, the auxiliary de-fluff filter **221** is adapted to trap in its meshes **520** fluff that has possibly escaped from the de-fluff filter **217** in order to prevent such fluff from reaching the heat exchanging units **225** and **230**.

[0102] The auxiliary de-fluff filter **221** provides an improved filtering capability to the air circuit by further reducing an amount of fluff able to reach the moisture condensing unit **225** and/or the air heating element **230**, thus considerably lowering the possibility of malfunction or efficiency reduction connected to fluff dispersed in the air circuit of the laundry machine **100**. The position of the auxiliary de-fluff filter **221** allow a user to perform an inspection and a cleaning thereof contextually with the inspection and the cleaning of the de-fluff filter **218**, while the strip-like shape of the auxiliary de-fluff filter **221** allows a cleaning as easy as possible thereof (e.g., it may be sufficient to rinse the auxiliary de-fluff filter with some water).

[0103] It should be noted that the laundry machine **100** may operate also without the auxiliary de-fluff filter **221** in its working position, i.e. with only the de-fluff filter **218** filtering the air flow coming from the laundry treatment chamber **105**.

Claims

1. A laundry machine (**100**) adapted to dry laundry by means of a flow of drying air, comprising:

a casing (**110**) for accommodating components necessary for the operation of the laundry machine (**100**);

inside the casing, a laundry treating chamber (**105**) adapted to contain the laundry to be dried; a casing top element (**125**) incorporating at least part of an air circuit in fluid communication with the laundry treating chamber through an inlet opening (**210**) and through an outlet opening (**215**), and defining an air-path for the flow of drying air between said inlet (**210**) and outlet (**215**) openings, said casing top element (**125**) comprising:

a inner panel (**235**) and a base element (**205**), the inner panel (**235**) being adapted to couple with at least a portion of the base element (**205**) in such a way to define the air-path for the flow of drying,

a first filter housing (**217**) for removably accommodating a first de-fluff filter (**218**), said filter housing (**217**) being provided in the air-path and being accessible through a housing aperture (**219**) provided on the casing top element (**125**);

a first de-fluff filter (**218**) for trapping fluff or lint particles carried by the flow of drying air crossing said de-fluff filter (**218**), the first de-fluff filter (**218**) comprising a filtering element (**321**) and a hollow chamber (**361**) accessible through an inlet aperture (**330**) and through an outlet portion (**303d**),

characterized in that

in the air-path for the flow of drying air defined by the casing top element (**125**), the laundry machine (**100**) further comprises a second filter housing (**505u,505l**) and a second de-fluff filter (**221**) removably received in the second filter housing (**505u,505l**);

the first and second filter housings (**217,505u,505l**) being provided between the inner panel (**235**) and the base element (**205**);

the first filter housing (**217**) is accessible through a filter aperture (**219**), said filter aperture (**219**) being delimited by a separating wall (**205a**) having a slot (**555**) for inserting/extracting the second de-fluff filter (**221**) in/from the second filter housing (**505u,505l**);

the second filter housing (**505u,505l**) comprises a first groove (**505u**) provided in the

inner panel (235) and a second groove (5051) provided in the base element (205) in such a way to be parallel and facing each other when the inner panel (235) is coupled with the at least a portion of the base element (205), a distance between the first groove (505u) and the second groove (5051) is designed to substantially correspond to a cross-sectional height of the second de-fluff filter (221) in such a way that the latter slidably fits the former; the first de-fluff filter (218) comprises an outlet portion (303d), and wherein the second filter housing (505u,5051) is provided facing said outlet portion (303d) when the first de-fluff filter (218) is inserted in the first filter housing (217); wherein the first filter housing (217) comprises an opened side (217d) having a frame (220) that defines a plurality of side windows (220a) separated one from the other by separating elements (220b), the second filter housing (505u,5051) being provided adjacent to the opened side (217d) of the first filter housing (217); the second de-fluff filter (221) is a strip-like element comprising a filtering portion (510f) adapted to filter the flow of drying air and a grasping portion (510g) adapted to be seized by a user during an insertion/extraction of the second de-fluff filter (221) in/from the second filter housing (505u,5051).

2. The laundry machine (100) according to claim 1, wherein the first and the second de-fluff filters (218,221) are slidably coupled to the casing top element (125).
3. The laundry machine (100) according to any one of the preceding claims, wherein the second filter housing (505u,5051) defines a path which elastically deforms the second de-fluff filter (221) when the latter is received/removed into/from said second filter housing (505u,5051).
4. The laundry machine (100) according to claim 1, wherein the grasping portion (510g) has a grip portion (530) comprising a plurality of ribs (535) formed transversally to an insertion/extraction direction of the second de-fluff filter (221) in/from the second filter housing (505u,5051), and/or comprising a finger hole (540) adapted to be hooked by a finger of a user.
5. The laundry machine (100) according to any preceding claims, wherein the first de-fluff filter (218) comprises at least one filtering mesh (321), and the second de-fluff filter (221) comprises at least one filtering mesh (520) which is finer than the filtering mesh

(321) of the first de-fluff filter (218).

6. The laundry machine (100) according to any of the preceding claims, wherein the second de-fluff filter (221) comprises a frame (515) that encircles a filtering portion (510f), which, in turn, comprises a plurality of filtering meshes (520), said frame (515) having a plurality of mullion elements (525) each mullion element (525) dividing two adjacent filtering meshes (520) from each other.
7. The laundry machine (100) according to claim 6, wherein each mesh (520) of the second de-fluff filter (221) is aligned with one of the plurality of side windows (220a) defined by the frame (220) of the opened side (217d) of the first filter housing (217).
8. The laundry machine (100) according to any one of the preceding claims, wherein the second de-fluff filter (221) comprises an elastically deformable engagement element (545) adapted to engage with a corresponding engagement portion provided on the second filter housing (505u,5051) for holding the second de-fluff filter (221) in place.
9. The laundry machine (100) according to any one of the preceding claims, wherein the second de-fluff filter (221) is made in resilient material so as to be elastically bent.

Patentansprüche

1. Wäschemaschine (100), die dazu ausgelegt ist, Wäsche mittels einer Strömung von Trocknungsluft zu trocknen, umfassend:

eine Einhausung (110) zum Beherbergen von Komponenten, die für den Betrieb der Wäschemaschine (100) erforderlich sind;

in der Einhausung, eine Wäschebehandlungskammer (105), die dazu ausgelegt ist, die zu trocknende Wäsche zu fassen;

ein Einhausungsoberseitenelement (125), das zumindest einen Teil eines Luftkreislaufs in Fluidverbindung mit der Wäschebehandlungskammer über eine Einlassöffnung (210) und über eine Auslassöffnung (215) einschließt und einen Luftweg für die Strömung von Trocknungsluft zwischen den Einlass(210)- und Auslass(215)-Öffnungen definiert, wobei das Einhausungsoberseitenelement (125) umfasst:

eine Innenplatte (235) und ein Basiselement (205), wobei die Innenplatte (235) dazu ausgelegt ist, mit zumindest einem Abschnitt des Basiselements (205) derart gekoppelt zu sein, dass der Luftweg für die

Strömung von Trocknungsluft definiert wird, ein erstes Filtergehäuse (217) zum entfernbaren Behergeben eines ersten Flusenfilters (218), wobei das Filtergehäuse (217) in dem Luftweg bereitgestellt ist und über einen Gehäusedurchgang (219) zugänglich ist, der an dem Einhausungsoberelement (125) bereitgestellt ist; einen ersten Flusenfilter (218) zum Auffangen von Flusen- oder Fusselteilchen, die durch die Strömung von Trocknungsluft, die den Flusenfilter (218) durchquert, mitgeführt werden, wobei der erste Flusenfilter (218) ein Filterungselement (321) und eine Hohlkammer (361) umfasst, die über einen Einlassdurchgang (330) und über einen Auslassabschnitt (303d) zugänglich ist, **dadurch gekennzeichnet, dass** in dem Luftweg für die Strömung von Trocknungsluft, der durch das Einhausungsoberelement (125) definiert ist, die Wäschemaschine (100) ferner ein zweites Filtergehäuse (505u, 5051) und einen zweiten Flusenfilter (221), der entferntbar in dem zweiten Filtergehäuse (505u, 5051) aufgenommen ist, umfasst; die ersten und zweiten Filtergehäuse (217, 505u, 5051) zwischen der Innenplatte (235) und dem Basiselement (205) bereitgestellt sind; das erste Filtergehäuse (217) über einen Filterdurchgang (219) zugänglich ist, wobei der Filterdurchgang (219) durch eine Trennwand (205a) begrenzt ist, die einen Schlitz (555) zum Einsetzen/Herausnehmen des zweiten Flusenfilters (221) in das/aus dem zweite(n) Filtergehäuse (505u, 5051) aufweist; das zweite Filtergehäuse (505u, 5051) eine erste Nut (505u), die in der Innenplatte (235) bereitgestellt ist, und eine zweite Nut (5051), die in dem Basiselement (205) derart bereitgestellt ist, dass sie parallel und einander zugewandt sind, wenn die Innenplatte (235) mit dem zumindest einen Abschnitt des Basiselements (205) gekoppelt ist, umfasst, wobei eine Distanz zwischen der ersten Nut (505u) und der zweiten Nut (5051) so ausgestaltet ist, dass sie im Wesentlichen einer Querschnittshöhe des zweiten Flusenfilters (221) derart entspricht, dass der letztere verschiebbar in die erstere passt; der erste Flusenfilter (218) einen Auslassabschnitt (303d) umfasst, und wobei das zweite Filtergehäuse (505u, 5051) so bereitgestellt ist, dass es dem Auslassabschnitt (303d) zugewandt ist, wenn der ers-

te Flusenfilter (218) in das erste Filtergehäuse (217) eingesetzt ist; wobei das erste Filtergehäuse (217) eine geöffnete Seite (217d) umfasst, die einen Rahmen (220) aufweist, der eine Mehrzahl von Seitenfenstern (220a) definiert, die durch Trennelemente (220b) voneinander getrennt sind, wobei das zweite Filtergehäuse (505u, 5051) angrenzend an die geöffnete Seite (217d) des ersten Filtergehäuses (217) bereitgestellt ist; der zweite Flusenfilter (221) ein streifenartiges Element ist, das einen Filterungsabschnitt (510f), der dazu ausgelegt ist, die Strömung von Trocknungsluft zu filtern, und einen Greifabschnitt (510g), der dazu ausgelegt ist, durch einen Benutzer während eines Einsetzens/Herausnehmens des zweiten Flusenfilters (221) in das/aus dem zweite(n) Filtergehäuse (505u, 5051) ergriffen zu werden, umfasst.

2. Wäschemaschine (100) nach Anspruch 1, wobei die ersten und die zweiten Flusenfilter (218, 221) verschiebbar mit dem Einhausungsoberelement (125) gekoppelt sind.
3. Wäschemaschine (100) nach einem der vorhergehenden Ansprüche, wobei das zweite Filtergehäuse (505u, 5051) einen Weg definiert, der den zweiten Flusenfilter (221) elastisch verformt, wenn der letztere in das/aus dem zweite(n) Filtergehäuse (505u, 5051) aufgenommen/entfernt wird.
4. Wäschemaschine (100) nach Anspruch 1, wobei der Greifabschnitt (510g) einen Griffabschnitt (530) aufweist, der eine Mehrzahl von Rippen (535) umfasst, die transversal zu einer Einsetz-/Entnahmerichtung des zweiten Flusenfilters (221) in das/aus dem zweite(n) Filtergehäuse (505u, 5051) ausgebildet sind, und/oder ein Fingerloch (540) umfasst, das dazu ausgelegt ist, durch einen Finger eines Benutzers eingehakt zu werden.
5. Wäschemaschine (100) nach einem der vorhergehenden Ansprüche, wobei der erste Flusenfilter (218) mindestens ein Filterungsgewebe (321) umfasst, und der zweite Flusenfilter (221) mindestens ein Filterungsgewebe (520) umfasst, das feiner als das Filterungsgewebe (321) des ersten Flusenfilters (218) ist.
6. Wäschemaschine (100) nach einem der vorhergehenden Ansprüche, wobei der zweite Flusenfilter (221) einen Rahmen (515) umfasst, der einen Filterungsabschnitt (510f) umgibt, der wiederum eine Mehrzahl von Filterungsgeweben (520) umfasst, wobei der Rahmen (515) eine Mehrzahl von Pfos-

tenelementen (525) aufweist, wobei jedes Pfosten-element (525) zwei angrenzende Filterungsgewebe (520) voneinander trennt.

7. Wäschemaschine (100) nach Anspruch 6, wobei jedes Gewebe (520) des zweiten Flusenfilters (221) mit einem der Mehrzahl von Seitenfenstern (220a), die durch den Rahmen (220) der geöffneten Seite (217d) des ersten Filtergehäuses (217) definiert sind, ausgerichtet ist. 5 10
8. Wäschemaschine (100) nach einem der vorhergehenden Ansprüche, wobei der zweite Flusenfilter (221) ein elastisch verformbares Eingriffselement (545) umfasst, das dazu ausgelegt ist, mit einem entsprechenden Eingriffsabschnitt in Eingriff zu kommen, der an dem zweiten Filtergehäuse (505u, 5051) zum Fixieren des zweiten Flusenfilters (221) bereitgestellt ist. 15 20
9. Wäschemaschine (100) nach einem der vorhergehenden Ansprüche, wobei der zweite Flusenfilter (221) aus einem nachgiebigen Material besteht, um elastisch gebogen zu werden. 25

Revendications

1. Machine (100) de blanchisserie prévue pour sécher du linge au moyen d'un flux d'air de séchage, comportant : 30
- une carrosserie (110) servant à recevoir des composants nécessaires au fonctionnement de la machine (100) de blanchisserie ; 35
- à l'intérieur de la carrosserie, une chambre (105) de traitement de linge prévue pour contenir le linge à sécher ;
- un élément (125) de dessus de carrosserie incorporant au moins une partie d'un circuit d'air en communication fluïdique avec la chambre de traitement de linge à travers une ouverture (210) d'entrée et à travers une ouverture (215) de sortie, et définissant un trajet d'air pour le flux d'air de séchage entre lesdites ouvertures d'entrée (210) et de sortie (215), ledit élément (125) de dessus de carrosserie comportant : 40 45
- un panneau intérieur (235) et un élément (205) de base, le panneau intérieur (235) étant prévu pour se coupler avec au moins une partie de l'élément (205) de base de manière à définir le trajet d'air pour le flux de séchage, un premier logement (217) de filtre servant à recevoir de façon amovible un premier filtre anti-peluches (218), ledit logement (217) de filtre étant placé dans le trajet d'air et étant accessible à travers un 50 55

orifice (219) de logement aménagé sur l'élément (125) de dessus de carrosserie ; un premier filtre anti-peluches (218) servant à piéger des particules de peluches ou de duvet transportées par le flux d'air de séchage traversant ledit filtre anti-peluches (218), le premier filtre anti-peluches (218) comportant un élément filtrant (321) et une chambre creuse (361) accessible à travers un orifice (330) d'entrée et à travers une partie (303d) de sortie, **caractérisé en ce que** sur le trajet d'air pour le flux d'air de séchage défini par l'élément (125) de dessus de carrosserie, la machine (100) de blanchisserie comporte en outre un second logement (505u, 5051) de filtre et un second filtre anti-peluches (221) reçu de façon amovible dans le second logement (505u, 5051) de filtre ; les premier et seconds logements (217, 505u, 5051) de filtre étant placés entre le panneau intérieur (235) et l'élément (205) de base ; le premier logement (217) de filtre est accessible à travers un orifice (219) de filtre, ledit orifice (219) de filtre étant délimité par une paroi (205a) de séparation dotée d'une fente (555) servant à insérer/extraire le second filtre anti-peluches (221) dans le/du second logement (505u, 5051) de filtre ; le second logement (505u, 5051) de filtre comporte une première rainure (505u) réalisée dans le panneau intérieur (235) et une seconde rainure (5051) réalisée dans l'élément (205) de base de manière à être parallèles et à se faire face lorsque le panneau intérieur (235) est couplé à la ou aux parties de l'élément (205) de base, une distance entre la première rainure (505u) et la seconde rainure (5051) étant conçue pour correspondre sensiblement à une hauteur en section droite du second filtre anti-peluches (221) de telle manière que la seconde s'ajuste de façon coulissante à la première ; le premier filtre anti-peluches (218) comporte une partie (303d) de sortie, et le second logement (505u, 5051) de filtre est placé face à ladite partie (303d) de sortie lorsque le premier filtre anti-peluches (218) est inséré dans le premier logement (217) de filtre ; le premier logement (217) de filtre comportant un côté ouvert (217d) doté d'un cadre (220) qui définit une pluralité de fenêtres latérales (220a) séparées les unes des autres par des éléments (220b) de séparation, le second logement (505u, 5051) de filtre étant placé au voisinage du côté ouvert (217d) du premier logement (217) de filtre ;

- le second filtre anti-peluches (221) est un élément de type bande comportant une partie filtrante (510f) prévue pour filtrer le flux d'air de séchage et une partie (510g) de préhension prévue pour être saisie par un utilisateur pendant une insertion/extraction du second filtre anti-peluches (221) dans le/du second logement (505u, 505l) de filtre.
2. Machine (100) de blanchisserie selon la revendication 1, les premier et second filtres anti-peluches (218, 221) étant couplés de façon coulissante à l'élément (125) de dessus de carrosserie. 5
 3. Machine (100) de blanchisserie selon l'une quelconque des revendications précédentes, le second logement (505u, 505l) de filtre définissant un trajet qui déforme élastiquement le second filtre anti-peluches (221) lorsque ce dernier est reçu/retiré dans ledit/du second logement (505u, 505l) de filtre. 10 15 20
 4. Machine (100) de blanchisserie selon la revendication 1, la partie (510g) de préhension comprenant une partie (530) de poignée comportant une pluralité de nervures (535) formées transversalement à une direction d'insertion/d'extraction du second filtre anti-peluches (221) dans le/du second logement (505u, 505l) de filtre, et/ou comportant un trou (540) pour doigt prévu pour être accroché par un doigt d'un utilisateur. 25 30
 5. Machine (100) de blanchisserie selon l'une quelconque des revendications précédentes, le premier filtre anti-peluches (218) comportant au moins un maillage filtrant (321), et le second filtre anti-peluches (221) comportant au moins un maillage filtrant (520) qui est plus fin que le maillage filtrant (321) du premier filtre anti-peluches (218). 35
 6. Machine (100) de blanchisserie selon l'une quelconque des revendications précédentes, le second filtre anti-peluches (221) comportant un cadre (515) qui encercle une partie filtrante (510f), qui comporte elle-même une pluralité de maillages filtrants (520), ledit cadre (515) comprenant une pluralité de éléments (525) de montants, chaque élément (525) de montant séparant deux maillages filtrants (520) adjacents l'un de l'autre. 40 45
 7. Machine (100) de blanchisserie selon la revendication 6, chaque maillage (520) du second filtre anti-peluches (221) étant aligné avec une fenêtre de la pluralité de fenêtres latérales (220a) définies par le cadre (220) du côté ouvert (217d) du premier logement (217) de filtre. 50 55
 8. Machine (100) de blanchisserie selon l'une quelconque des revendications précédentes, le second filtre anti-peluches (221) comportant un élément (545) d'interaction élastiquement déformable prévu pour interagir avec une partie d'interaction correspondante placée sur le second logement (505u, 505l) de filtre pour maintenir le second filtre anti-peluches (221) en place.
 9. Machine (100) de blanchisserie selon l'une quelconque des revendications précédentes, le second filtre anti-peluches (221) étant réalisé en matériau élastique de façon à être cintré élastiquement.

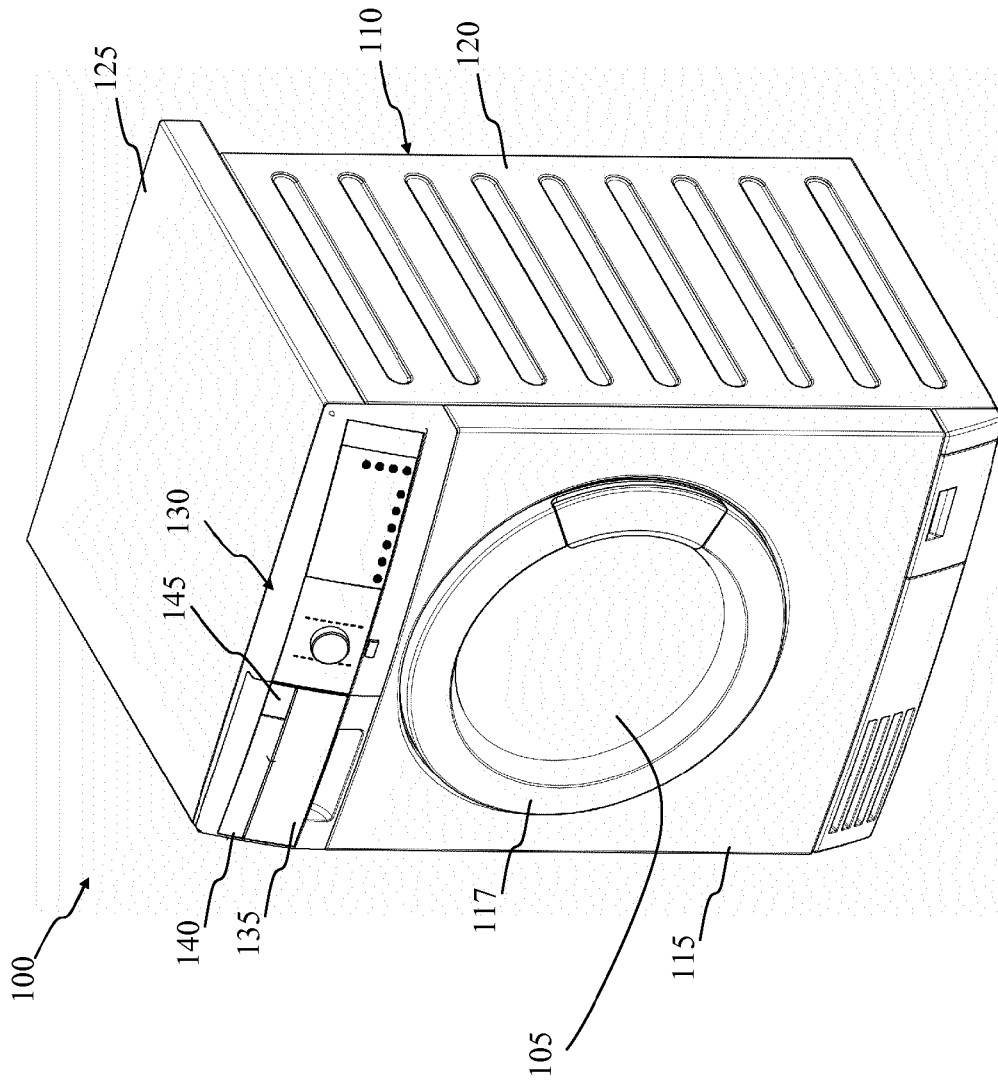

FIG. 1

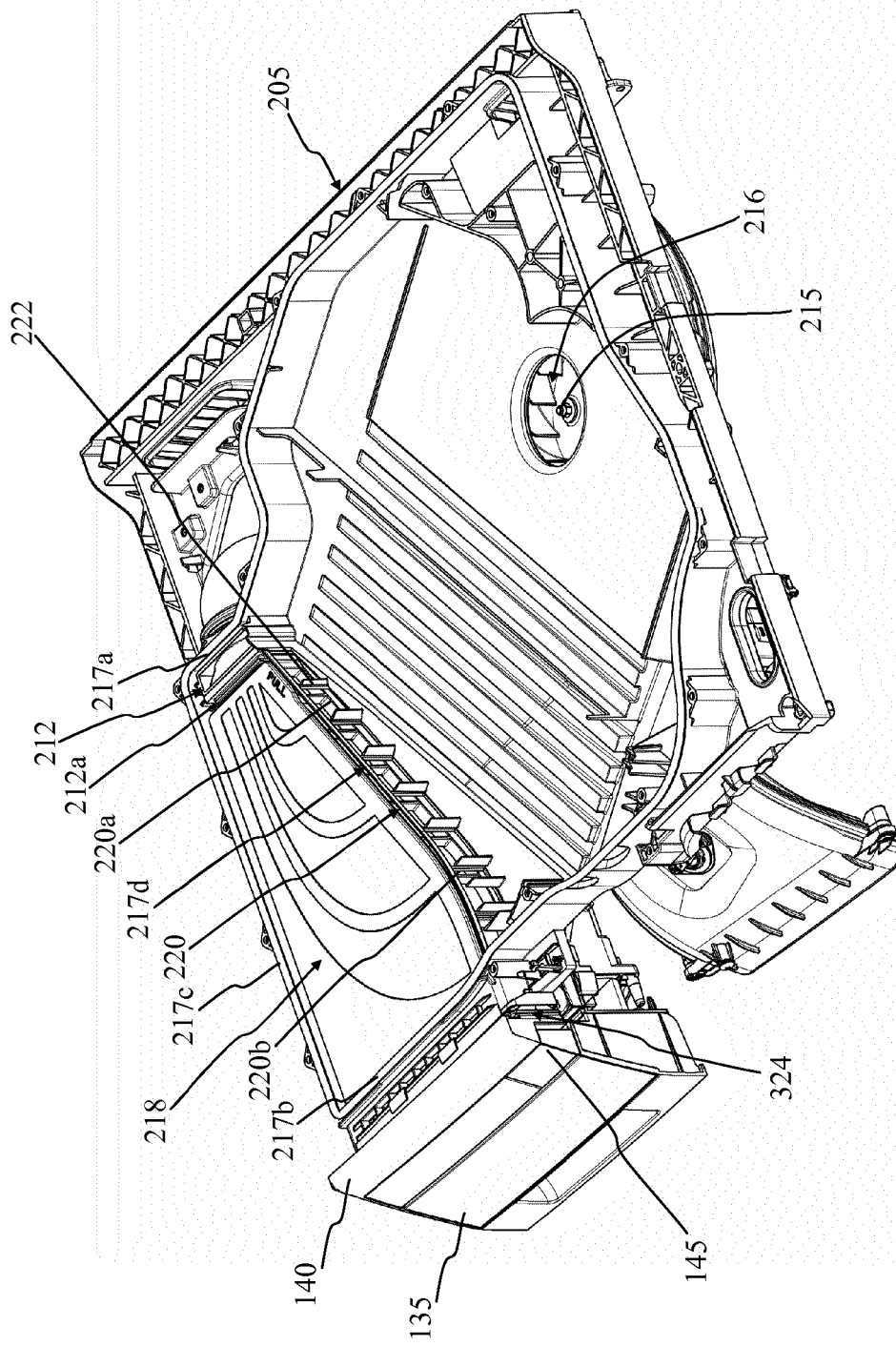

FIG.2B

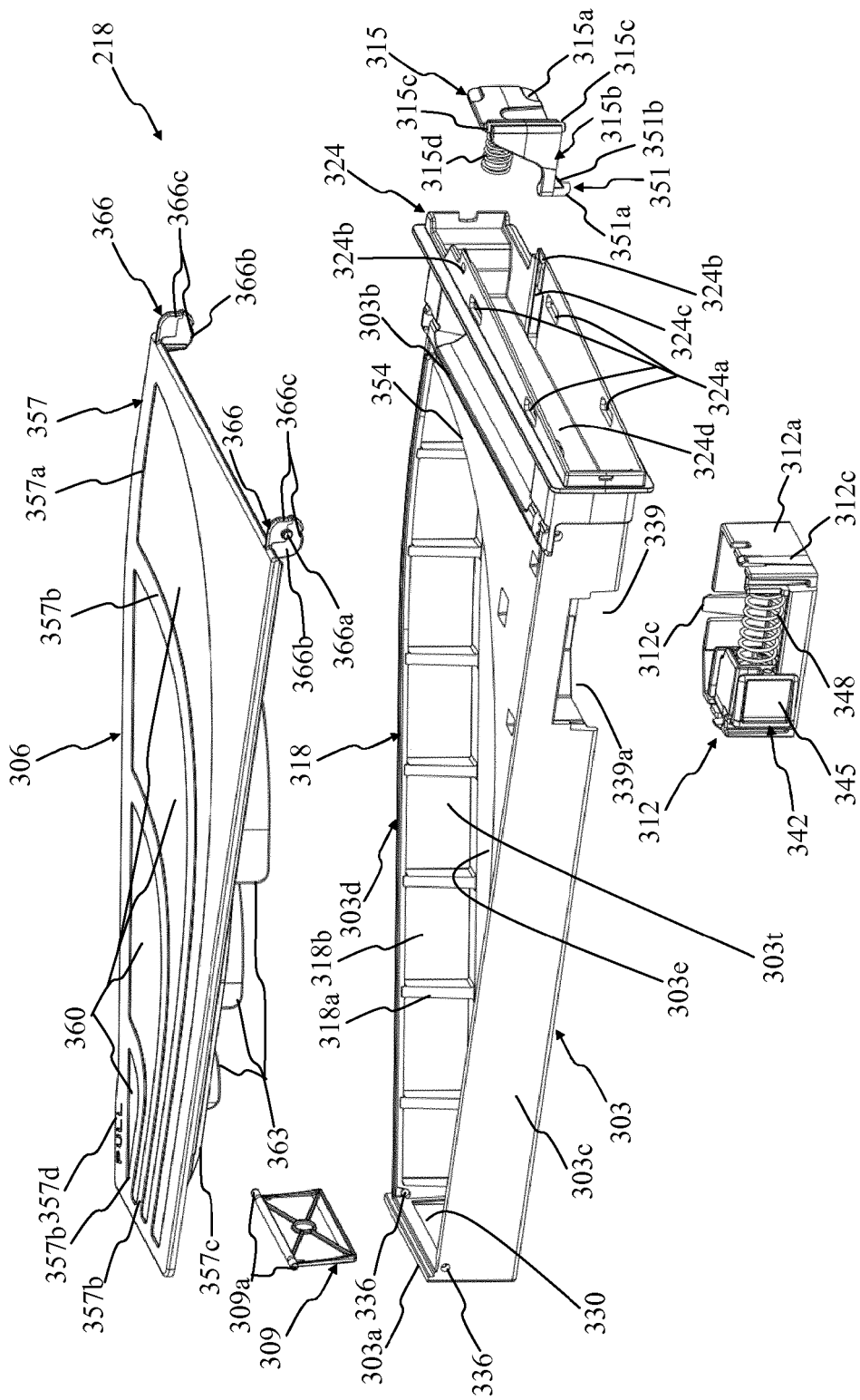

FIG.3A

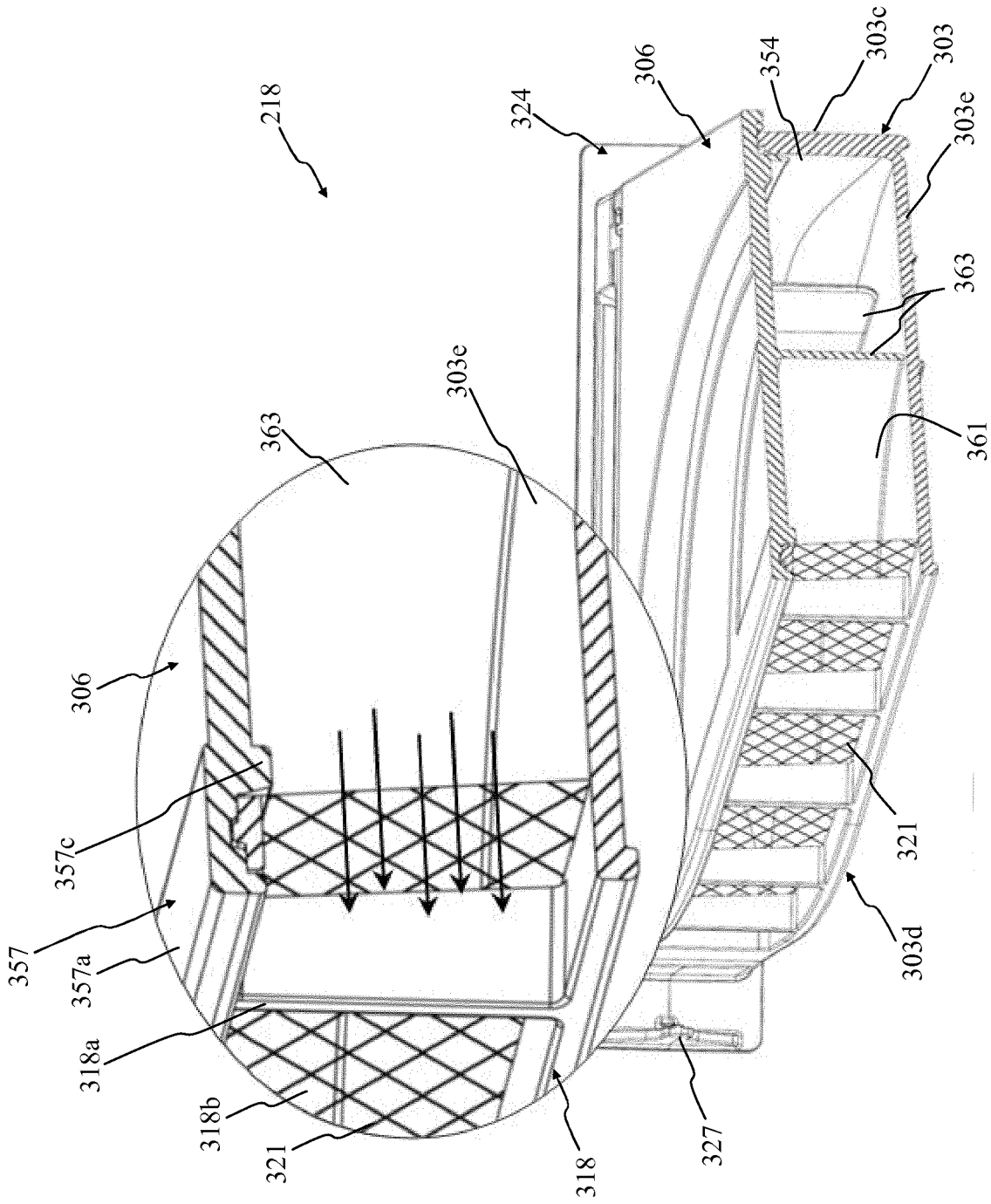

FIG.3B

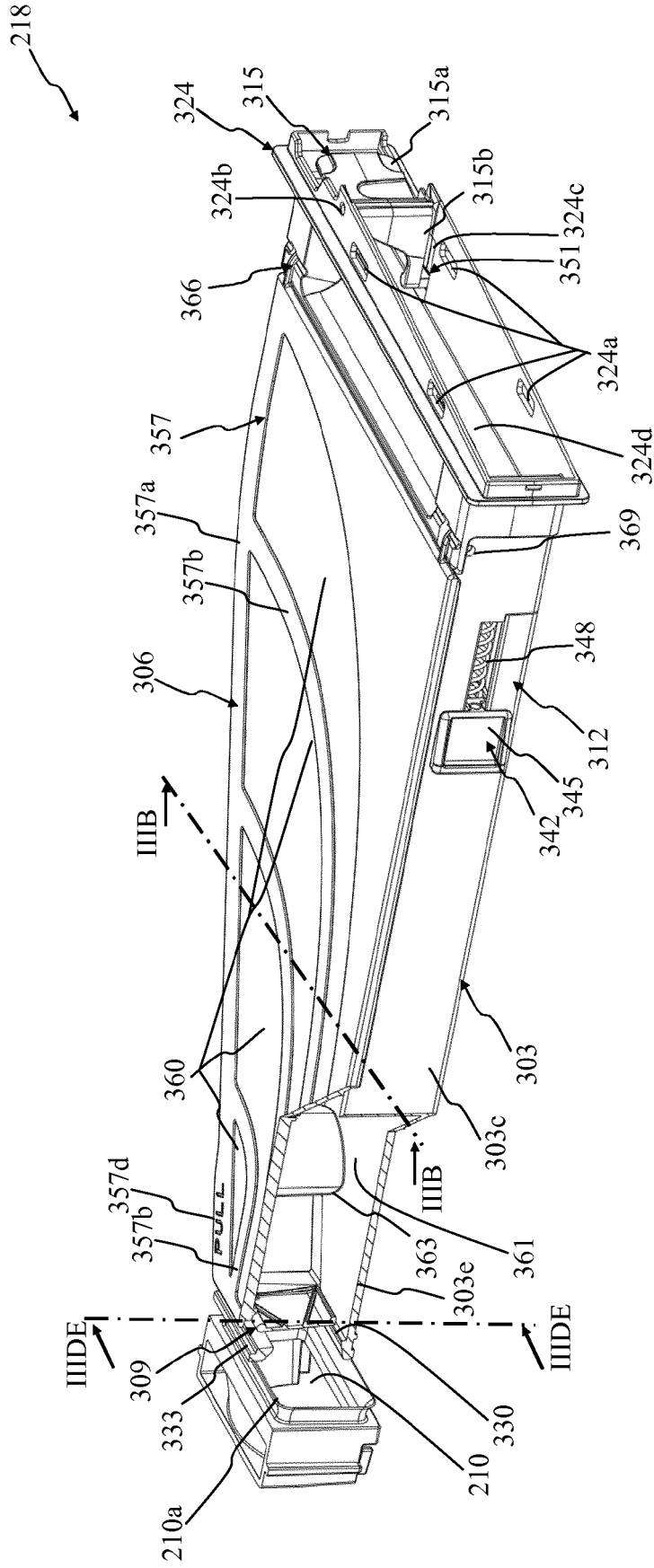

FIG.3C

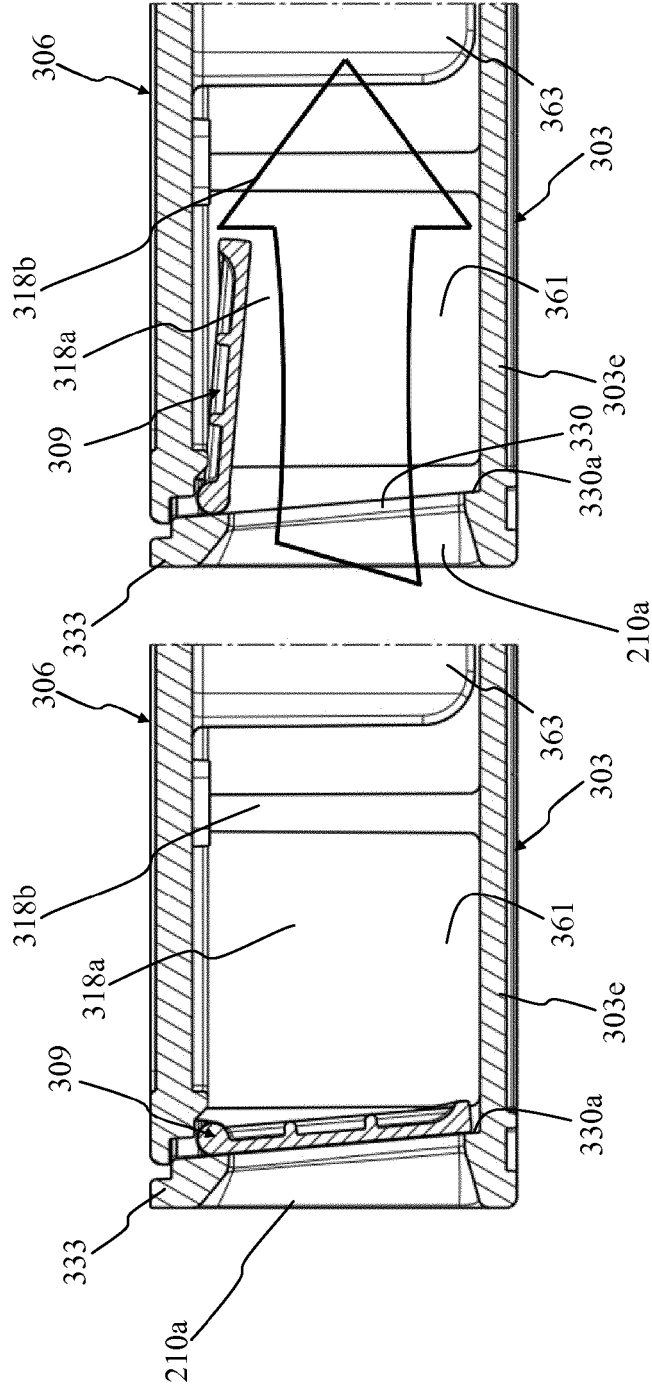

FIG. 3E

FIG. 3D

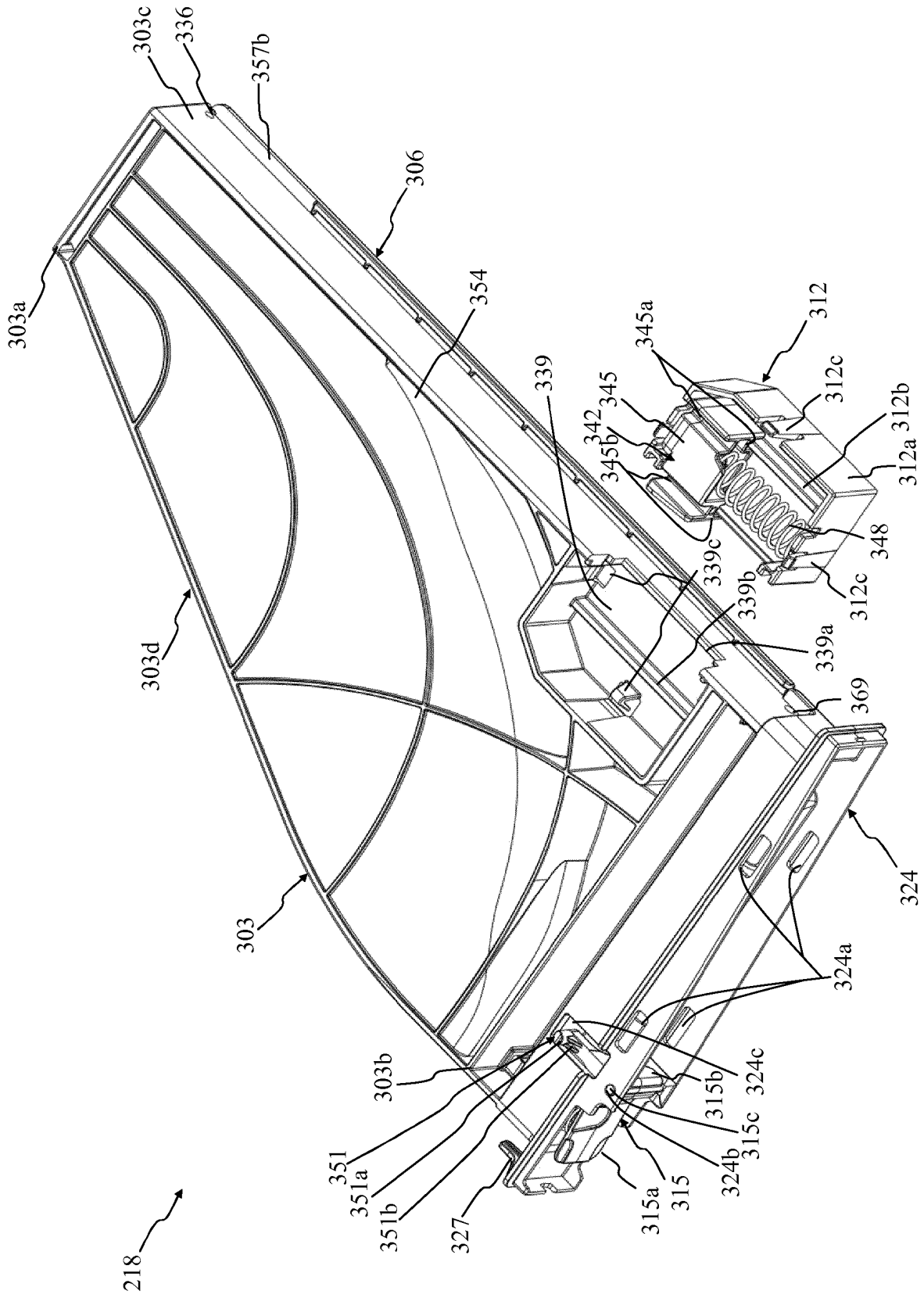

FIG.3F

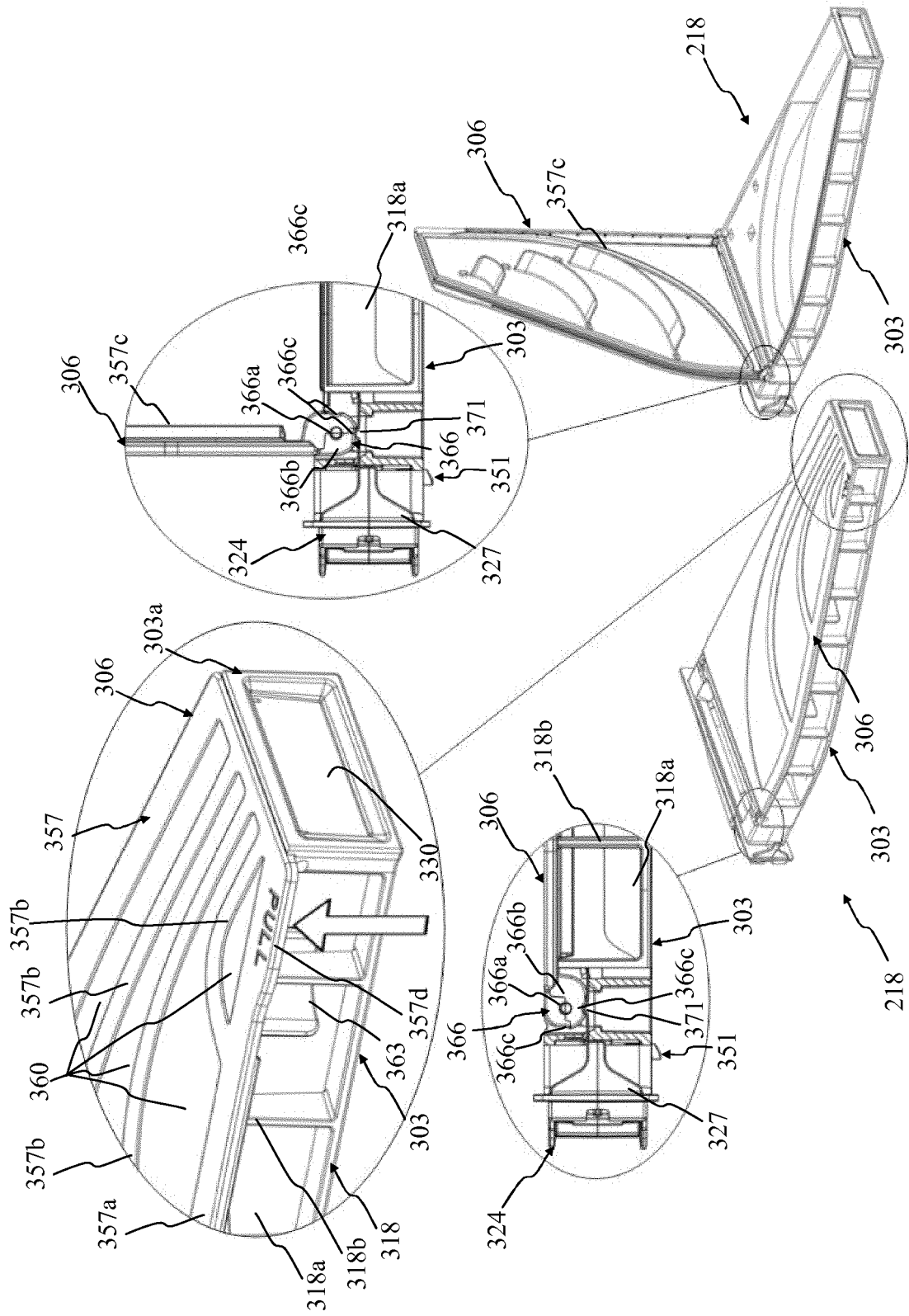

FIG.3H

FIG.3G

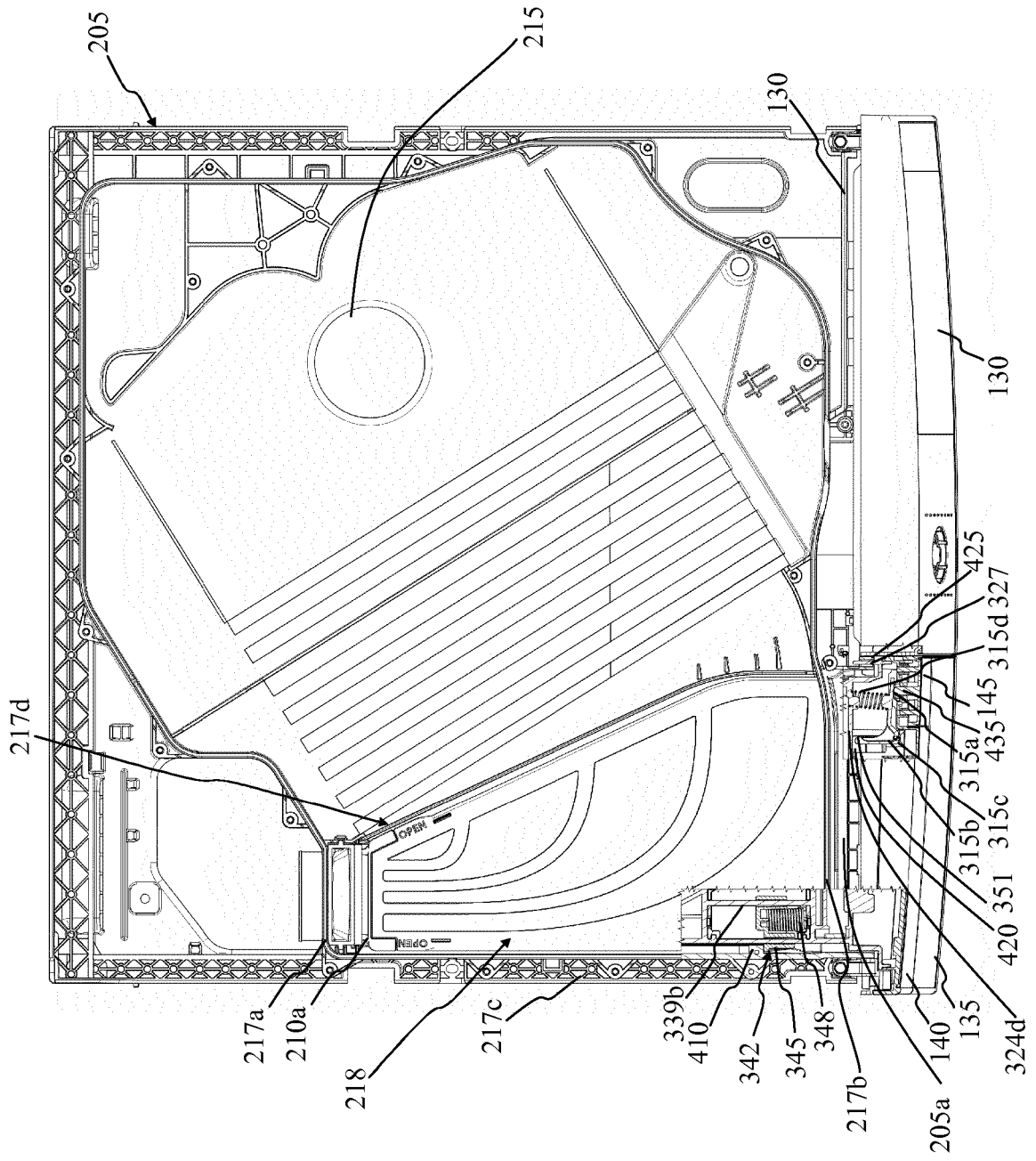

FIG. 4A

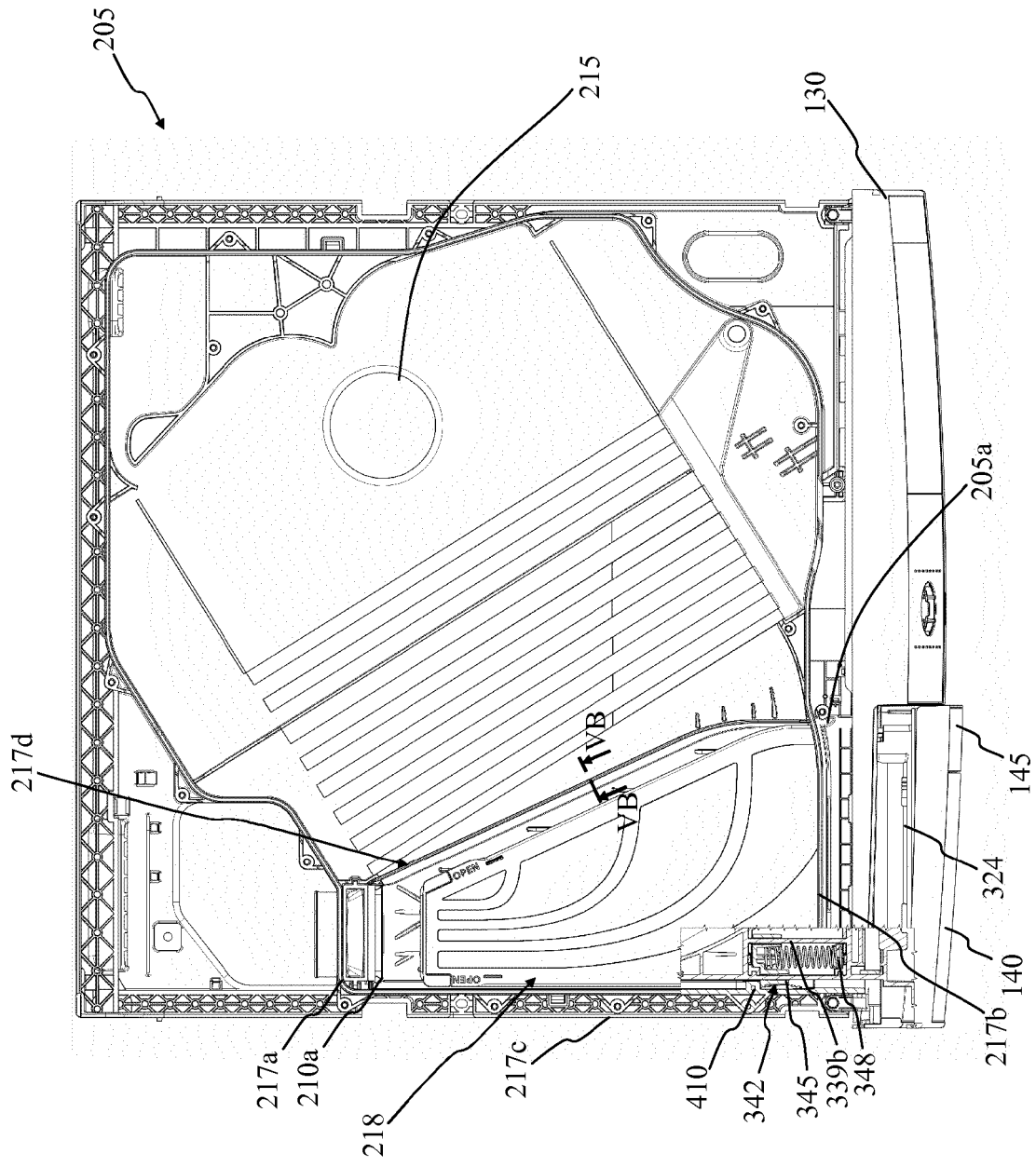

FIG. 4B

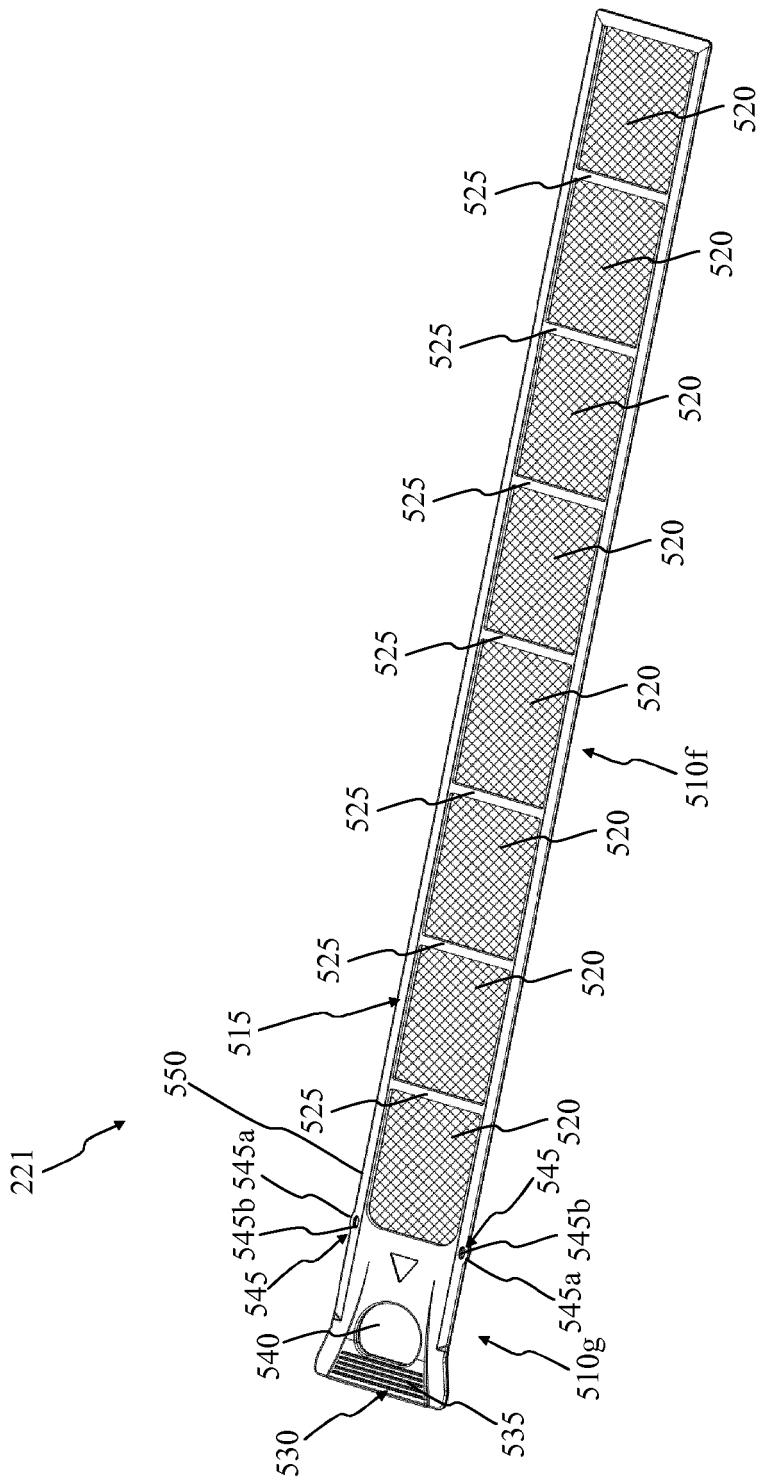

FIG.5A

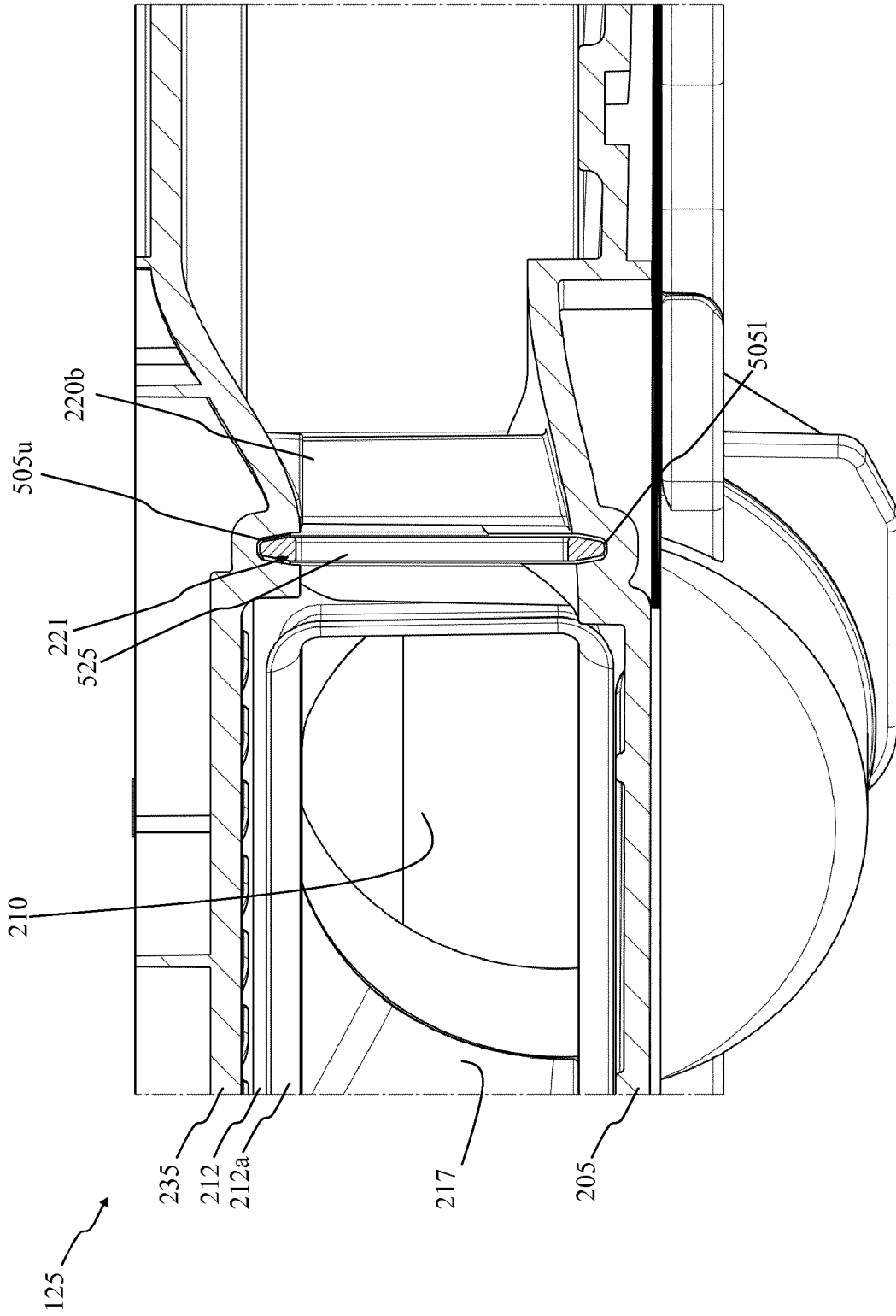

FIG. 5B

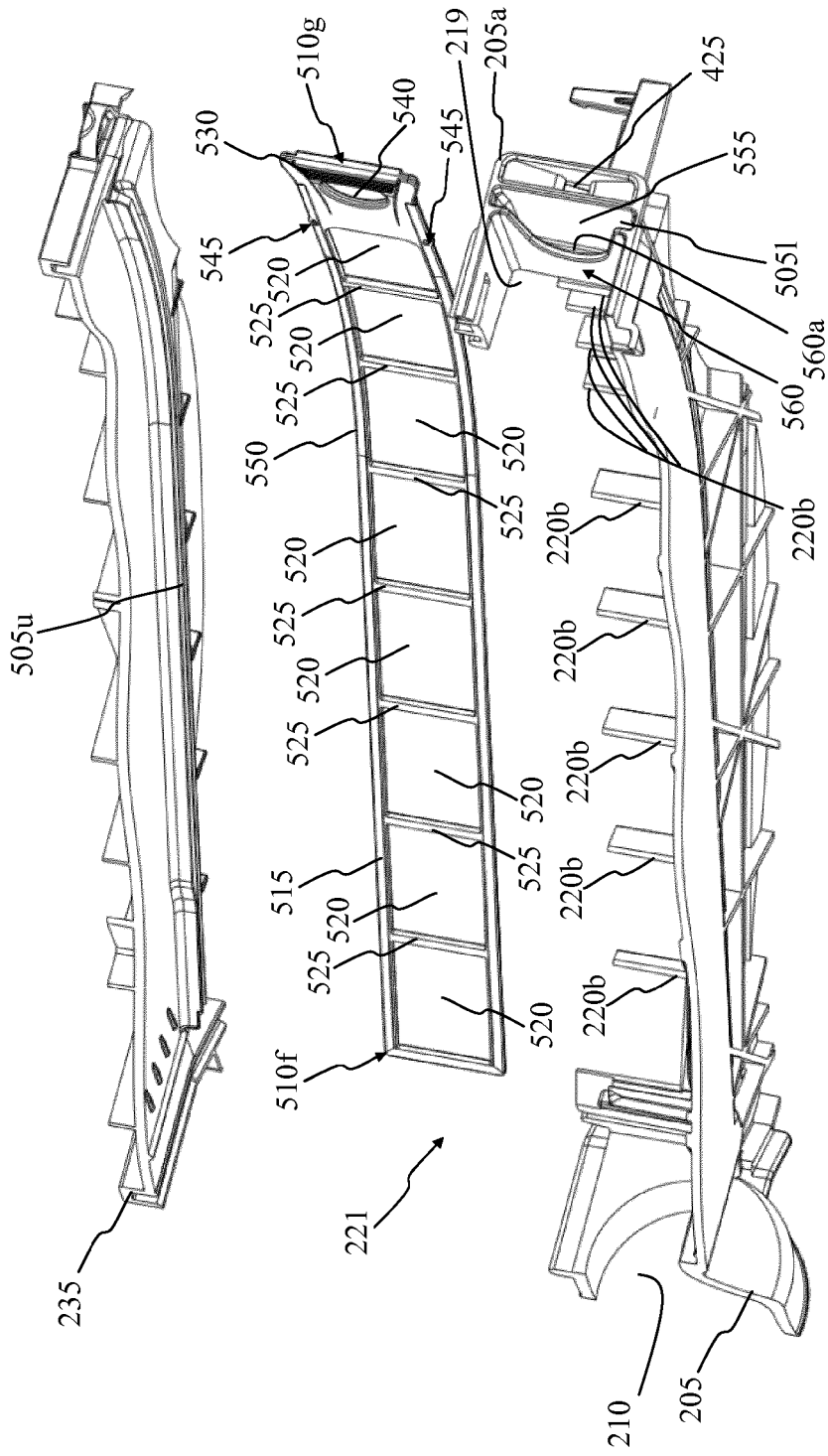

FIG.5C

REFERENCES CITED IN THE DESCRIPTION

This list of references cited by the applicant is for the reader's convenience only. It does not form part of the European patent document. Even though great care has been taken in compiling the references, errors or omissions cannot be excluded and the EPO disclaims all liability in this regard.

Patent documents cited in the description

- EP 2471994 A [0007]
- JP 2008079855 A [0008]
- US 7020986 B [0009]