

(19)



(11)

**EP 4 078 640 B1**

(12)

**EUROPEAN PATENT SPECIFICATION**

(45) Date of publication and mention of the grant of the patent:

**07.02.2024 Bulletin 2024/06**

(51) International Patent Classification (IPC):

**H01H 13/70** <sup>(2006.01)</sup>      **H01H 13/807** <sup>(2006.01)</sup>  
**H01H 13/705** <sup>(2006.01)</sup>      **H01H 13/12** <sup>(2006.01)</sup>  
**H01H 13/18** <sup>(2006.01)</sup>

(21) Application number: **19842899.7**

(52) Cooperative Patent Classification (CPC):

**H01H 13/70; H01H 13/705; H01H 13/807;**  
H01H 13/12; H01H 13/18; H01H 2221/032

(22) Date of filing: **20.12.2019**

(86) International application number:

**PCT/PL2019/050079**

(87) International publication number:

**WO 2021/125983 (24.06.2021 Gazette 2021/25)**

(54) **SHORT STROKE BUTTON ASSEMBLY AND A KEYPAD CONTAINING SUCH SHORT STROKE BUTTON ASSEMBLY**

KURZHUB-TASTENANORDNUNG UND STEUERTASTATUR MIT SOLCH EINER KURZHUB-TASTENANORDNUNG

ENSEMBLE DE BOUTONS À COURSE COURTE ET CLAVIER COMPRENANT CELUI-CI

(84) Designated Contracting States:

**AL AT BE BG CH CY CZ DE DK EE ES FI FR GB GR HR HU IE IS IT LI LT LU LV MC MK MT NL NO PL PT RO RS SE SI SK SM TR**

- **SYREK, Wojciech**  
**34-113 Sosnowice (PL)**

(43) Date of publication of application:

**26.10.2022 Bulletin 2022/43**

(74) Representative: **Lukaszyk, Szymon**

**Kancelaria Patentowa Lukaszyk**  
**Ul. Glowackiego 8/5**  
**40-052 Katowice (PL)**

(73) Proprietor: **Merit Poland Sp. z o.o.**

**30-394 Kraków (PL)**

(56) References cited:

**US-A1- 2008 316 064      US-A1- 2018 074 587**  
**US-A1- 2019 178 729      US-B1- 10 325 734**

(72) Inventors:

- **KWIECIE , Leszek**  
**32-031 Chorowice (PL)**

**EP 4 078 640 B1**

Note: Within nine months of the publication of the mention of the grant of the European patent in the European Patent Bulletin, any person may give notice to the European Patent Office of opposition to that patent, in accordance with the Implementing Regulations. Notice of opposition shall not be deemed to have been filed until the opposition fee has been paid. (Art. 99(1) European Patent Convention).

## Description

**[0001]** The present invention relates to a short stroke button assembly, in particular for use in an automotive vehicle, comprising a housing, at least one button held in said housing and apt to be moved axially in the activation direction along an activation axis, at least one switch corresponding to said button, having an active state and an inactive state separated by an activation gap along said activation axis, and normally maintaining said inactive state, and at least one connector disposed between said button and said switch. The present invention relates also to a keypad comprising a number of such short stroke button assemblies.

### Background of the invention

**[0002]** Button assemblies of this kind are commonly used in consumer devices to provide a distinct tactile response of the button, with a short activation stroke that can amount to 0.5 mm or less.

**[0003]** Unfortunately the chain of tolerances of the particular components of the assembly generates range of lengths between the button and the switch that do not correspond to the activation gap of the switch. This in turn may manifest in a loose fit of the assembly components leading to noise upon pressing the button and a general poor user feeling, sometimes referred to as a "slack", or in an extensive preload of the switch that can cause its unwanted activation.

**[0004]** These adverse effects are obviously multiplied in a keypad comprising a number of short stroke button assemblies, where some buttons may work properly, some buttons may be loose and some buttons may be permanently activated.

**[0005]** Patent publication US2013220789 discloses a process for characterizing a tactile response of a button based on a back off distance. The first mechanical actuator includes a plunger, a dome-shaped flexible membrane, and an electrical contact, all aligned with each other so that a contact signal is generated when the flexible membrane touches the contact. The plunger can be moved a first distance towards the contact until the contact signal is generated at a contact point. Then the plunger can be backed off a second distance from the contact point. The particular feel of the first mechanical actuator can then be correlated to a particular back off distance. This process can be repeated a number of times to classify a number of different "feels" for the first mechanical actuator based on a number of different back off distances.

**[0006]** Patent publication US2008316064 discloses an electronic device comprising a keypad structure and a printed circuit board. The keypad structure comprises a switch, a keypad body, and a touching element. The keypad body having a through hole is disposed relatively to the switch. The touching element is inserted into the through hole and has an adjusting portion. The adjusting

portion of the touching element has a notch. The touching element is screwed in the through hole by engaging a receiving tool with the notch, for moving the touching element relatively to the keypad body so as to change the touching distance. The touching distance could be determined and adjusted according to the user's feeling of touching the keypad,

**[0007]** The publication US 2018/074587 A1 describes a button assembly according to the preamble of claim 1.

**[0008]** It has been the object of the present invention to provide a compact, cost efficient and simple to manufacture short stroke button assembly of the kind mentioned in the outset provided with a simple regulation mechanism in order to adjust the assembly precisely to maintain its inactive state corresponding to or lower than the activation gap.

**[0009]** Another object of the present invention has been to provide a keypad comprising a number of short stroke button assemblies, in which all buttons would provide substantially the same tactile response with substantially the same activation stroke.

### Summary of the invention

**[0010]** The invention provides a short stroke button assembly as set forth in claim 1. Further embodiments are inter alia disclosed in the dependent claims.

**[0011]** The term "substantially helical surface" as used in the specification denotes a surface having the property that the tangent line at any point makes an angle, but not necessarily constant angle, with said activation axis.

**[0012]** According to the invention said first member or said second member is integral with said button, while said second member or said first member is angularly displaceable with respect to the housing.

**[0013]** Said means to maintain relative angular position between said first member and said second member of said connector comprise at least one radial recess or projection formed in one member engageable with at least two radial projections or recesses formed in the other member.

**[0014]** Preferably said button assembly comprises least two radial projections or recesses, formed in said first member or said second member, angularly displaceable with respect to the housing and engageable with at least one radial recess or projection maintaining stable position with respect to the housing.

**[0015]** According to the invention said first member and/or said second member is provided with an interface for a torque applying tool, while said assembly is further provided with at least one control channel to introduce said torque applying tool.

**[0016]** This interface may have a form of a slot, cross, hex, torx, etc. socket or projection.

**[0017]** Preferably said control channel passes through the button.

**[0018]** Preferably said control channel passes through the housing and the switch.

**[0019]** Preferably said first member is provided with a cavity along said activation axis having an internal wall, and said second member provided with a longitudinal protrusion disposed inside said cavity of said first member.

**[0020]** Preferably said first member is proximal to said button and said second member is proximal to said switch.

**[0021]** Preferably said first member is proximal to said switch and said second member is proximal to said button.

**[0022]** Preferably said switch has a form of an elastomeric dome shaped member defining a chamber and provided with an activating element inside said chamber, and a support member having an electrical contact corresponding to said activating element of said elastomeric dome shaped member.

**[0023]** Preferably said dome shaped member is formed by an elastomeric sheet.

**[0024]** The invention also provides a keypad comprising a number of short stroke button assemblies as defined above.

#### Brief description of drawings

**[0025]** The invention shall be described and explained below in connection with the attached drawings in which:

Fig. 1 is a schematic top view of an embodiment of a keypad according to the present invention;

Fig. 2 is a schematic axonometric view of an embodiment of a short stroke button assembly according to the present invention;

Fig. 3 is a schematic axonometric and exploded view of the button assembly shown in Fig. 2;

Fig. 4 is a schematic cross-sectional view of the button assembly shown in Fig. 2;

Fig. 5 is a schematic cross-sectional view of the button assembly shown in Fig. 2. perpendicular to the view shown in Fig. 4;

Fig. 6 is a schematic cross-sectional view of an enlarged fragment D of Fig. 4;

Fig. 7 is a schematic axonometric view of a connector of the short stroke button assembly shown in Fig. 2,

Fig. 8 is a schematic cross-sectional view of the connector shown in Fig. 7 along the plane C-C of Fig. 5;

Fig. 9 is a schematic cross-sectional view of another embodiment of a connector corresponding to the view shown in Fig. 8;

Fig. 10 is a schematic axonometric view of yet another embodiment of a connector of a short stroke button assembly;

Fig. 11 is a schematic axonometric view of yet another embodiment of a connector of a short stroke button assembly;

Fig. 12 is a schematic cross-sectional view of the connector shown in Fig. 11; and

Fig. 12 is a bottom view of the connector shown in

Fig. 11.

#### Detailed description of preferred embodiments

**[0026]** In the following description numerical references of elements performing the same functions remain the same in the drawings, wherein suffixes (a, b, ...) were added, where appropriate, to additionally distinct elements having different construction.

**[0027]** Fig. 1 shows an embodiment of a keypad 1 according to the present invention comprising twelve short stroke buttons 4 each assigned a unique function and controlling a monostable (i.e. returning back to original position after released) switch electrically connected to a controlled system (not shown). Keypad of this type can be used in automotive vehicles but also in other control systems, such as computers, mobile devices, etc.

**[0028]** An embodiment of a short stroke button assembly 2 shown in Figs. 2-8 comprises a housing 3 and a button 4 held in the housing 3 apt to be moved axially in the activation direction along an activation axis A. The button 4 cooperates with a switch 5 through a connector 8a disposed between the button 4 and the switch 5. The switch 5 has an active state and an inactive state separated by an activation gap L (cf. Fig. 6) along said activation axis A and is preloaded to normally maintain said inactive state.

**[0029]** In this embodiment the switch 5, best shown in Figs. 4-6, comprises an elastomeric sheet 6 adjoining a support member 7 in a form of a printed circuit board disposed inside the housing 3. The elastomeric sheet 6 abuts the support member 7 and the support member 7 abuts a housing cover 31 snap-locked within the housing 3. Obviously in an embodiment of a keypad 1 shown in Fig. 1, one housing 3, one elastomeric sheet 6, one support member 7 and one housing cover 31 can be common for all the buttons 4.

**[0030]** As best shown in Fig. 6 the elastomeric sheet 6 comprises an elastomeric dome shaped member 61 facing the button 4 and normally maintaining an expanded, disengaged state due to elastic forces. The dome shaped member 61 defines a chamber 62 and a tubular projection 63 facing the support member 7. The edge of the tubular projection 63 is provided with a conductive layer 64 and the support member 7 is provided with an electrical contacts 74. The conductive layer 64 and the electrical contacts 74 are separated by the activation gap L, which in this embodiment amounts about 0.5 mm.

**[0031]** As it is known from the state of art, when user presses the button 4, the connector 8a moves downward acting on the dome shaped member 61, which collapses and eventually, in an active state, the conductive layer 64 of the tubular projection 63 short-circuits the electrical contacts 74 of the support member 7 having two or more separate electrical paths (not shown), thus creating a conducting path between them and transmitting the signal to the external controlled system (not shown), that the button assembly 2 is coupled with. When user releases

es the button 4, strain energy stored in the dome shaped member 61 during its deformation is released forcing the dome shaped member 61 to return to its neutral position along with the button 4. To this end, the button 4 abuts the holding means (not shown) of the housing 3 preventing the button 4 to spring out during the rebound action of the dome shaped member 61.

**[0032]** In this embodiment the connector 8a comprises a first member 81 provided with a longitudinal cavity 811, extending along the activation axis A, and a second member 82 having a longitudinal protrusion 821 disposed inside the longitudinal cavity 811 of the first member 81. In this embodiment the first member 81 is proximal to the button 4 and the second member 82 is proximal to the switch 8. Furthermore in this embodiment the first member 81 is formed as an integral part of the button 4.

**[0033]** The connector 8a is further provided with means to maintain the relative angular position between the first member 81 and the second member 82 when the torque between these members is below a predefined threshold. In the embodiment shown in Figs. 3-8, the longitudinal cavity 811 of the first member 81 has an internal wall 812 provided with six equiangularly spaced radial recesses 813a. The longitudinal protrusion 821 is provided with two opposite radial projections 823a disposed inside the corresponding two radial recesses 813a of the internal wall 812 of the longitudinal cavity 811 of the first member 81. Therefore the rotation of the first member 81 w/r/t the second member 82 if the torque between these member is below a predefined value is blocked.

**[0034]** Furthermore the first member 81 comprises a protrusion 814 extending along the activation axis A, adjoining the axial face of the longitudinal cavity 811 and flush with the internal wall 812. The second member 82 further comprises a substantially helical surface 824 adjoining to and cooperating with the protrusion 814. which functionality shall be explained later.

**[0035]** The second member 82 is provided at its face proximal to the button 4 with a first interface 825a for a torque applying tool, which in this embodiment has a form of a Torx socket. Furthermore the second member 82 is provided at its face proximal to the switch 5, and adjoining the dome shaped member 61, with a similar second interface 825b also in a form of a Torx socket.

**[0036]** In this embodiment the button assembly 2 is further provided with two control channels 9 to introduce said torque applying tools (torx keys). The first control channel 9a passes through the pressing face of the button 4 and enables access to the first interface 825a of the second member 82. The second channel 9b passes through the housing cover 31 and the switch 5 (in particular through an opening 71 in the support member 7 and the cylindrical projection 63 of the dome shaped member 61 of the elastomeric sheet 6), to enable access to the second interface 825b of the second member 82.

**[0037]** Upon introduction of an appropriate torque applying tool into the interface 825a or 825b through the control channel 9a or 9b and application of a torque suf-

ficient to move the radial projections 823a of the second member 82 out of the equilibrium positions defined by the radial recesses 813a of the first member 81, one may rotate the second member 82 w/r/t the first member 81.

In this process the protrusion 814 of the first member 81 will slide along the helical surface 824 of the second member 82 extending or shortening the length of the connector 8a along the activation axis A. In other embodiments of the present invention, the button 4 might be angularly displaceable with respect to the housing 3 about the axis A and integral with the first member 81 (or the second member 82), so that torque required to modify the length of the connector 8 could be applied directly on the button 4 (without any control channel 9) with the second member 82 (or the first member 81) provided with appropriate means supporting its angular position.

**[0038]** In this embodiment of the invention the adjustment of the button assembly 2 by extending or shortening the length of the connector 8a is possible only in discrete steps corresponding to the adjoining equilibrium positions defined by the radial recesses 813a of the first member 81. To facilitate this switching of radial projections 823a of the second member 82 between the radial recesses 813a of the first member 81, the second member 82 is provided between the radial projections 823a with an internal longitudinal cavity 826 that facilitate radial contraction of the radial projections 823a.

**[0039]** Such an adjustment of the button assembly 2 may be performed by turning the first member 81 w/r/t the second member 82 in a direction extending the length of the connector 8 until the switch 5 is activated. At this point the members 81 and 82 may be turned one step in the opposite direction to inactivate the switch 5. In this position the preload of the switch 5 will be transferred to the other components of the assembly removing any perceivable "slackness".

**[0040]** In the case of a keypad 1 comprising a number of button assemblies 2 the adjustment may be conveniently automated and performed by an array of torque applying rotatable tools each regulating a single button assembly 2.

**[0041]** Another embodiment of a connector 8b is shown in Fig. 9. The connector 8b has a similar construction to the one of the connector 8a with slightly different means to maintain the relative angular position between the first member 81 and the second member 82. Here the internal wall 812 of the longitudinal cavity 811 of the first member 81 has a radial projection 813b, while the external wall 822 of the longitudinal protrusion 821 of the second member 82 has six equiangularly spaced radial recesses 823b.

**[0042]** Another embodiment of the connector 8c is shown in Fig. 10. Here both a first member 81c and a second member 82c are solid blocks, wherein first member 81c is provided with a number of axial guiding fingers 815 holding the second member 82c to maintain its axial position between the members 81c and 82c.

**[0043]** In this embodiment the means to maintain the

relative angular position between the first member 81 and the second member 82 when the torque between the first member 81 and the second member 82 is below a predefined threshold, have a form of an additional high friction, elastomeric layer 83 deposited radially between the first member 81c and the second member 82, or more precisely on the radially internal surfaces of the axial guiding fingers 815 of the first member 81c.

**[0044]** Yet another embodiment of the connector 8d is shown in Figs. 11-13. Here the means to maintain the relative angular position between the first member 81 and the second member 82 comprise a number of radial, equiangularly spaced recesses 823d formed in the second member 82 angularly displaceable about and axially along the activation axis A with respect to the first member (not shown), which is integral with the button 4, as well as with respect to the housing 3. The recesses 823d are engageable with at least one radial projection 32d fixed to the housing 3. The above embodiments of the present invention are therefore merely exemplary. The figures are not necessarily to scale and some features may be exaggerated or minimized. These and other factors however should not be considered as limiting the scope of the invention, which is defined by the appended claims.

#### List of reference numerals

#### [0045]

- 1. keypad
- 2. button assembly
- 3. housing
  - 31. housing cover
  - 32d. radial projection
- 4. button
- 5. switch
- 6. elastomeric sheet
  - 61. dome shaped member
  - 62. chamber
  - 63. tubular projection
  - 64. conductive layer
- 7. support member (printed circuit board)
  - 71. opening
  - 74. electrical contact
- 8. connector (8a, 8b, 8c, 8d)
  - 81. first member
    - 811. longitudinal cavity
    - 812. internal wall
    - 813a. radial recess

- 813b. radial projection
- 814. protrusion
- 815. guiding finger
- 82. second member
  - 821. longitudinal protrusion
  - 822. external wall
  - 823a. radial projection
  - 823b radial recess
  - 823d radial recess
  - 824. helical surface
  - 825. interface for a torque applying tool (825a, 825b)
  - 826. internal cavity
- 83. high friction layer
- 9. control channel (9a, 9b)

#### Claims

1. A short stroke button assembly (2), in particular for use in an automotive vehicle, comprising
  - a housing (3),
  - a button (4) held in said housing (2) and apt to be moved axially in the activation direction along an activation axis (A),
  - at least one switch (5) corresponding to said button (4), having an active state and an inactive state separated by an activation gap (L) along said activation axis (A), and preloaded to normally maintain said inactive state, and
  - at least one connector (8) disposed along said activation axis (A) between said button (4) and said switch (5), wherein
  - said connector (8) comprises
  - a first member (81) and a second member (82) displaceable angularly about and axially along said activation axis (A) with respect to said first member (81),
  - wherein said first member (81) comprises at least one protrusion (814) extending along said activation axis (A) and said second member (82) further comprises at least one substantially helical surface (824) cooperating with said protrusion (814),
  - characterized in that**
  - at least one radial recess (813a) or projection (813b) formed in one member (81, 82) engageable with at least two radial projections (823a) or recesses (823b) formed in the other member (82, 81) to maintain the relative angular position between said first member (81) and said second member (82), wherein
  - said first member (81) or said second member

- (82) is integral with said button (4), while said second member (82) or said first member (81) is angularly displaceable with respect to the housing (3), wherein said first member (81) and/or said second member (82) is provided with an interface (825a, 825b) for a torque applying tool, while said assembly (2) is further provided with at least one control channel (9a, 9b) to introduce said torque applying tool.
2. The button assembly according to Claim 1, **characterized in that**, it comprises at least two radial projections or recesses (823d), formed in said first member or said second member (82), angularly displaceable with respect to the housing (3) and engageable with at least one radial recess or projection (32d) maintaining stable position with respect to the housing (3).
  3. The button assembly according to Claim 1 or 2, **characterized in that**, said control channel (9a) passes through the button (4).
  4. The button assembly according to Claim 1 or 2, **characterized in that**, said control channel (9b) passes through the housing and the switch (5).
  5. The button assembly according to any one of the preceding Claims, **characterized in that**, said first member (81) is provided with a cavity (811) along said activation axis (A) having an internal wall (812), and said second member (82) is provided with a longitudinal protrusion (821) disposed inside said cavity (811) of said first member (81).
  6. The button assembly according to any one of Claims 1 to 5, **characterized in that**, said first member (81) is proximal to said button (4) and said second member (82) is proximal to said switch (5).
  7. The button assembly according to any one of Claims 1 to 5, **characterized in that**, said first member is proximal to said switch (5) and said second member is proximal to said button (4).
  8. The button assembly according to any one of the preceding Claims, **characterized in that**, said switch (5) has a form of an elastomeric dome shaped member (61) defining a chamber (62) and provided with an activating element (64) inside said chamber (62), and a support member (7) having an electrical contact (74) corresponding to said activating element (64) of said elastomeric dome shaped member (61).
  9. The button assembly according to Claim 8, **characterized in that**, said dome shaped member (61) is

formed by an elastomeric sheet (6).

10. A keypad (1) comprising a number of short stroke button assemblies (2) defined in any one of Claims 1 to 9.

#### Patentansprüche

1. Eine Kurzhubtastenbaugruppe (2), insbesondere zur Verwendung in einem Kraftfahrzeug, bestehend aus
  - einem Gehäuse (3),
  - einer Taste (4), die in dem Gehäuse (2) gehalten wird und axial in der Aktivierungsrichtung entlang einer Aktivierungsachse (A) bewegt werden kann,
  - mindestens einem Schalter (5), der der Taste (4) entspricht, einen aktiven Zustand und einen inaktiven Zustand aufweist, die durch einen Aktivierungsspalt (L) entlang der Aktivierungsachse (A) getrennt sind, und vorgespannt ist, um normalerweise den inaktiven Zustand beizubehalten, und
  - mindestens einem Verbinder (8), der entlang der Aktivierungsachse (A) zwischen der Taste (4) und dem Schalter (5) angeordnet ist, wobei der Verbinder (8) ein erstes Element (81) und ein zweites Element (82) umfasst, die in Bezug auf das erste Element (81) winklig um und axial entlang der Aktivierungsachse (A) verschiebbar sind, wobei das erste Element (81) mindestens einen Vorsprung (814) aufweist, der sich entlang der Aktivierungsachse (A) erstreckt, und das zweite Element (82) ferner mindestens eine im Wesentlichen schraubenförmige Oberfläche (824) aufweist, die mit dem Vorsprung (814) zusammenwirkt,] **dadurch gekennzeichnet, dass** mindestens eine radiale Aussparung (813a) oder ein Vorsprung (813b), die bzw. der in einem Element (81, 82) ausgebildet ist und mit mindestens zwei radialen Vorsprüngen (823a) oder Aussparungen (823b), die in dem anderen Element (82, 81) ausgebildet sind, in Eingriff gebracht werden kann, um die relative Winkelposition zwischen dem ersten Element (81) und dem zweiten Element (82) beizubehalten, wobei das erste Element (81) oder das zweite Element (82) mit der Taste (4) einstückig ist, während das zweite Element (82) oder das erste Element (81) in Bezug auf das Gehäuse (3) winklig verschiebbar ist, wobei das erste Element (81) und/oder das zweite Element (82) mit einer Schnittstelle (825a, 825b) für ein Drehmomentwerkzeug versehen ist, während die Baugruppe (2) ferner mit mindes-

tens einem Kontrollkanal (9a, 9b) zum Einführen des Drehmomentwerkzeugs versehen ist.

2. Die Tastenbaugruppe nach Anspruch 1, **dadurch gekennzeichnet, dass** sie mindestens zwei radiale Vorsprünge oder Aussparungen (823d) umfasst, die in dem ersten Element oder dem zweiten Element (82) ausgebildet sind, die in Bezug auf das Gehäuse (3) winklig verschiebbar sind und mit mindestens einer radialen Aussparung oder einem radialen Vorsprung (32d) in Eingriff gebracht werden können, der eine stabile Position in Bezug auf das Gehäuse (3) beibehält.
3. Die Tastenbaugruppe nach Anspruch 1 oder 2, **dadurch gekennzeichnet, dass** der Kontrollkanal (9a) durch die Taste (4) verläuft.
4. Die Tastenbaugruppe nach Anspruch 1 oder 2, **dadurch gekennzeichnet, dass** der Kontrollkanal (9b) durch das Gehäuse und den Schalter (5) verläuft.
5. Die Tastenbaugruppe nach einem der vorhergehenden Ansprüche, **dadurch gekennzeichnet, dass** das erste Element (81) mit einem Hohlraum (811) entlang der Aktivierungsachse (A) versehen ist, der eine Innenwand (812) aufweist, und dass das zweite Element (82) mit einem Längsvorsprung (821) versehen ist, der innerhalb des Hohlraums (811) des ersten Elements (81) angeordnet ist.
6. Die Tastenbaugruppe nach einem der Ansprüche 1 bis 5, **dadurch gekennzeichnet, dass** sich das erste Element (81) in der Nähe der Taste (4) und das zweite Element (82) in der Nähe des Schalters (5) befindet.
7. Die Tastenbaugruppe nach einem der Ansprüche 1 bis 5, **dadurch gekennzeichnet, dass** sich das erste Element in der Nähe des Schalters (5) und das zweite Element in der Nähe der Taste (4) befindet.
8. Die Tastenbaugruppe nach einem der vorhergehenden Ansprüche, **dadurch gekennzeichnet, dass** der Schalter (5) die Form eines elastomeren, kuppelförmigen Elements (61) hat, das eine Kammer (62) definiert und mit einem Aktivierungselement (64) innerhalb der Kammer (62) versehen ist, und ein Trägerelement (7) mit einem elektrischen Kontakt (74), der dem Aktivierungselement (64) des elastomeren, kuppelförmigen Elements (61) entspricht.
9. Die Tastenbaugruppe nach Anspruch 8, **dadurch gekennzeichnet, dass** das kuppelförmige Element (61) durch eine Elastomerfolie (6) gebildet ist.
10. Eine Tastatur (1) mit einer Anzahl von Kurzhubtas-

tenbaugruppen (2) nach einem der Ansprüche 1 bis 9.

## 5 Revendications

1. Un ensemble de boutons à faible course (2), en particulier pour utilisation dans un véhicule automobile, comprenant
  - un boîtier (3),
  - un bouton (4) maintenu dans ledit boîtier (2) et apte à être déplacé axialement dans la direction d'activation le long d'un axe d'activation (A),
  - au moins un commutateur (5) correspondant audit bouton (4), ayant un état actif et un état inactif séparés par un espace d'activation (L) le long dudit axe d'activation (A), et préchargé pour maintenir normalement ledit état inactif, et
  - au moins un connecteur (8) disposé le long dudit axe d'activation (A) entre ledit bouton (4) et ledit commutateur (5), dans lequel
  - ledit connecteur (8) comprend
  - un premier élément (81) et un second élément (82) déplaçable angulairement autour et axialement le long dudit axe d'activation (A) par rapport audit premier élément (81), dans lequel
  - ledit premier élément (81) comprend au moins une saillie (814) s'étendant le long de ladite axe d'activation (A) et ledit second élément (82) comprend en outre au moins une surface sensiblement hélicoïdale (824) coopérant avec ladite saillie (814), **caractérisé en ce que** au moins un évidement radial (813a) ou une saillie radiale (813b) formés dans un élément (81, 82) peut s'engager avec au moins deux saillies radiales (823a) ou renforcements radiaux (823b) formés dans l'autre élément (82, 81) afin de maintenir la position angulaire relative entre ledit premier élément (81) et ledit second élément (82), dans lequel
  - ledit premier élément (81) ou ledit second élément (82) est solidaire dudit bouton (4), tandis que ledit second élément (82) ou ledit premier élément (81) est angulairement déplaçable par rapport au boîtier (3), dans lequel
  - ledit premier élément (81) et/ou ledit second élément (82) est pourvu d'une interface (825a, 825b) pour un outil d'application de couple, tandis que ledit ensemble (2) est en outre pourvu d'au moins un canal de commande (9a, 9b) pour introduire ledit outil d'application de couple.
2. L'ensemble de boutons selon la revendication 1, **caractérisé en ce qu'il** comprend au moins deux saillies ou évidements radiaux (823d), formés dans ledit premier élément ou ledit second élément (82), déplaçables angulairement par rapport au boîtier (3)

et pouvant être engagés avec au moins un évidement radial ou une saillie radiale (32d) maintenant une position stable par rapport au boîtier (3).

3. L'ensemble de boutons selon les revendications 1 ou 2, **caractérisé en ce que** le canal de commande (9a) traverse le bouton (4). 5
4. L'ensemble de boutons selon les revendications 1 ou 2, **caractérisé en ce que** le canal de commande (9b) traverse le boîtier et le commutateur (5). 10
5. L'ensemble de boutons selon l'une quelconque des revendications précédentes, **caractérisé en ce que**, ledit premier élément (81) est pourvu d'une cavité (811) le long dudit axe d'activation (A) ayant une paroi interne (812), et ledit second élément (82) est pourvu d'une protubérance longitudinale (821) disposée à l'intérieur de ladite cavité (811) dudit premier élément (81). 15  
20
6. L'ensemble de boutons selon l'une quelconque des revendications 1 à 5, **caractérisé en ce que** ledit premier élément (81) est proche dudit bouton (4) et ledit second élément (82) est proche dudit commutateur (5). 25
7. L'ensemble de boutons selon l'une des revendications 1 à 5, **caractérisé en ce que** le premier élément est proche du commutateur (5) et le second élément est proche du bouton (4). 30
8. L'ensemble de boutons selon l'une quelconque des revendications précédentes, **caractérisé en ce que** ledit commutateur (5) se présente sous la forme d'un élément en forme de dôme élastomère (61) définissant une chambre (62) et pourvu d'un élément d'activation (64) à l'intérieur de ladite chambre (62), et d'un élément de support (7) présentant un contact électrique (74) correspondant audit élément d'activation (64) dudit élément en forme de dôme élastomère (61). 35  
40
9. L'ensemble de boutons selon la revendication 8, **caractérisé en ce que** ledit élément en forme de dôme (61) est formé par une feuille d'élastomère (6). 45
10. Un clavier (1) comprenant un certain nombre d'ensembles de boutons à faible course (2) définis dans l'une quelconque des revendications 1 à 9. 50  
55

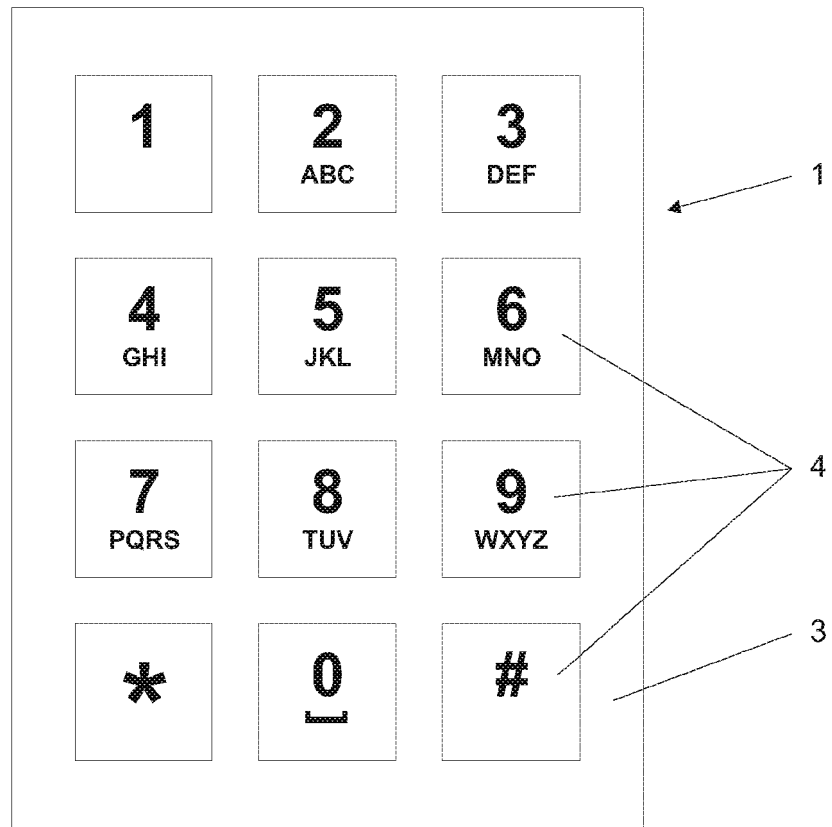

Fig. 1

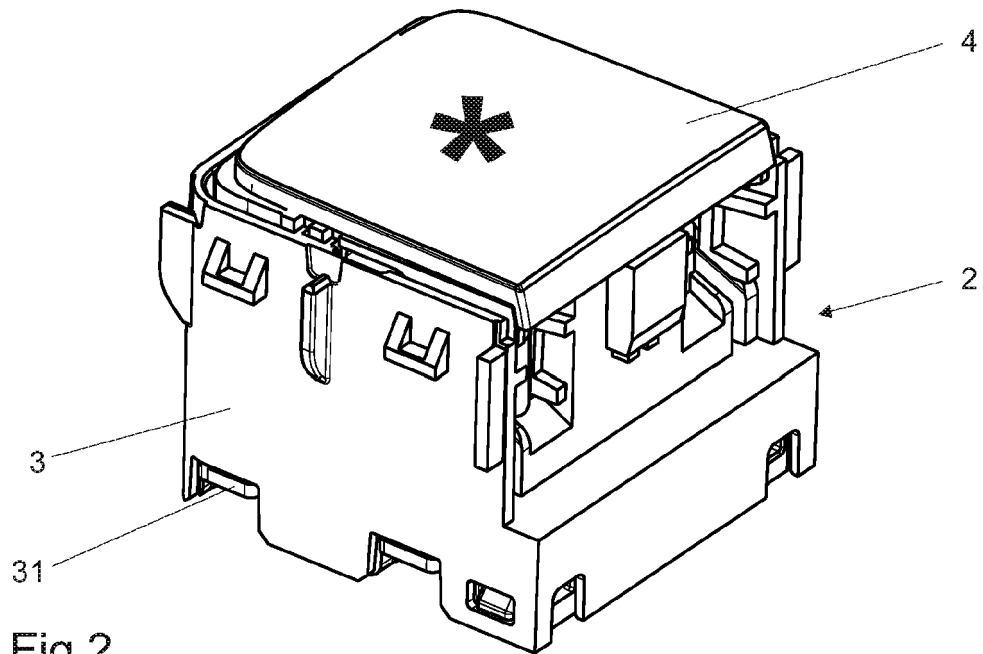
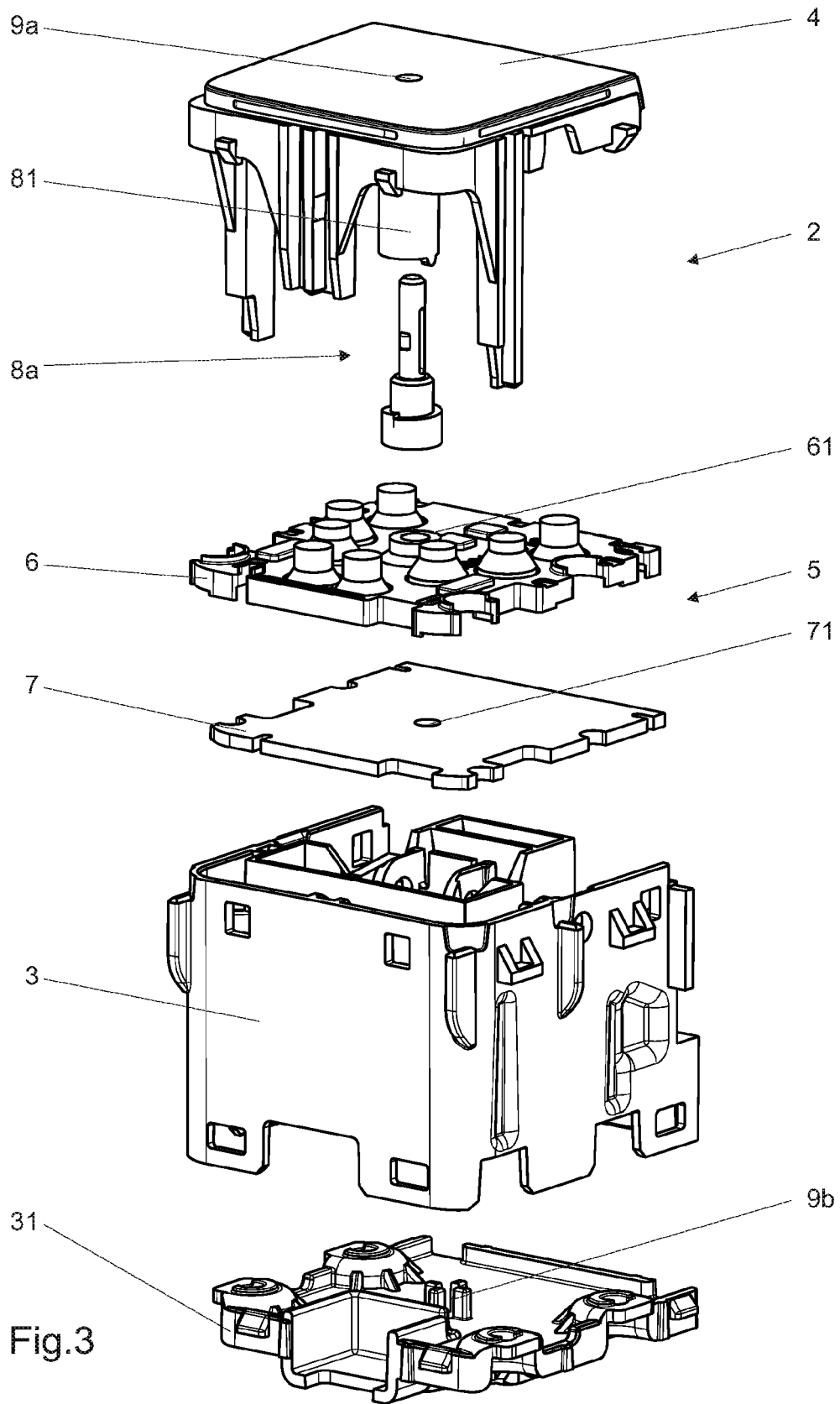

Fig. 2



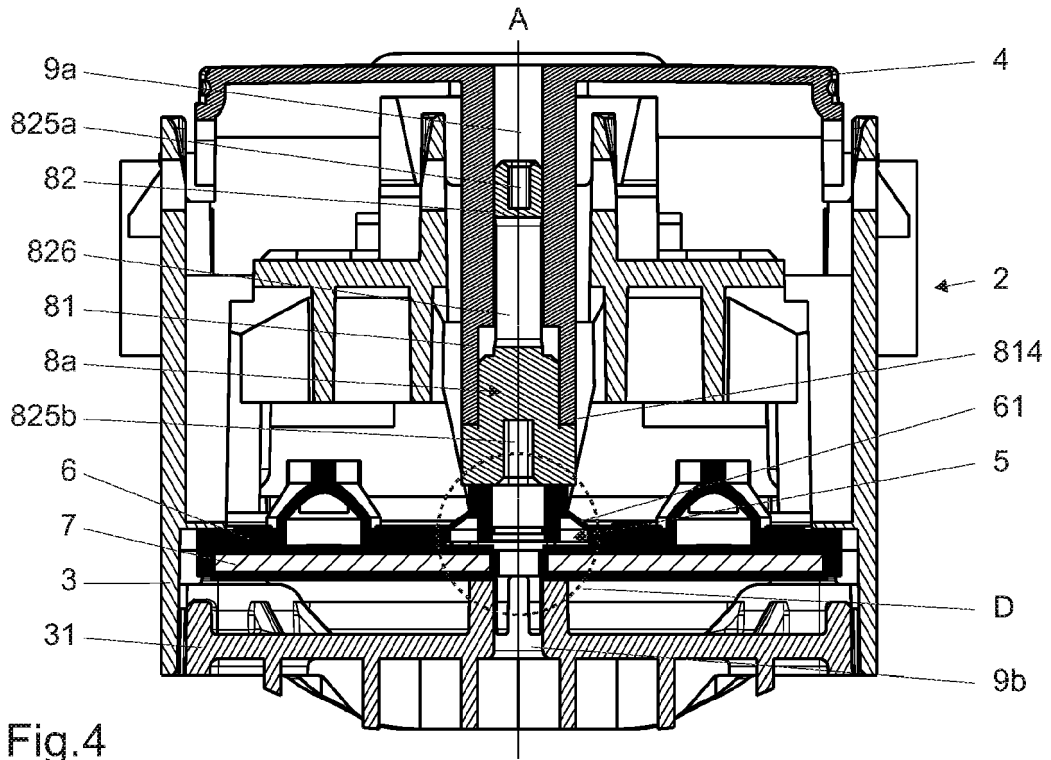

Fig. 4

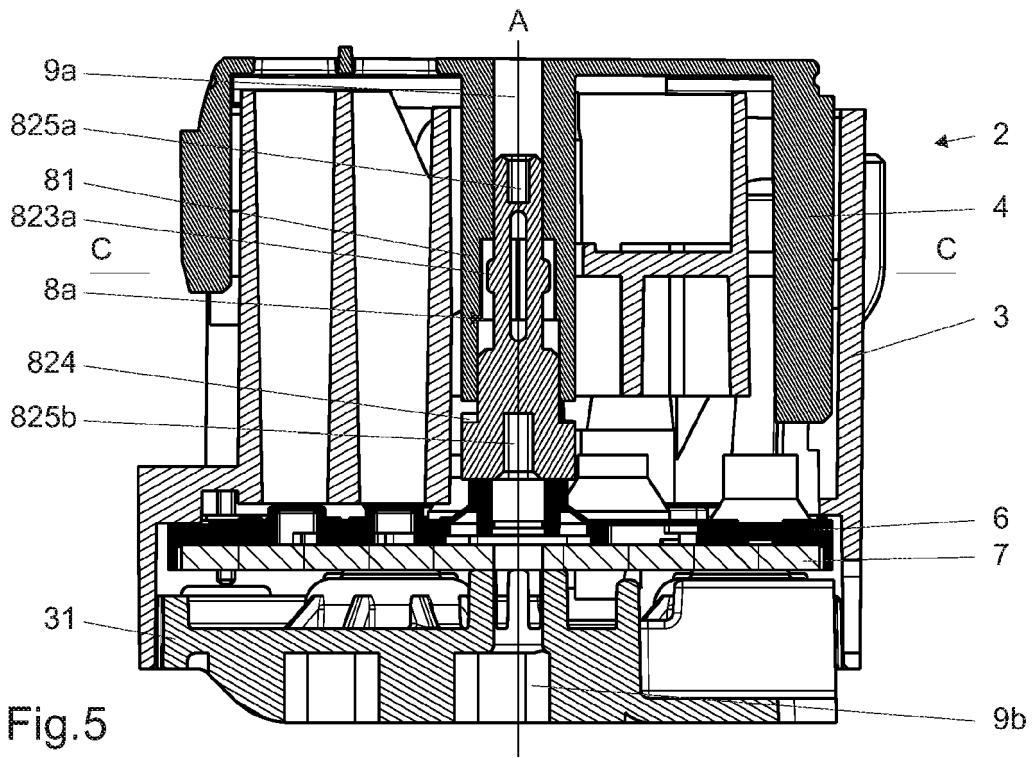

Fig. 5

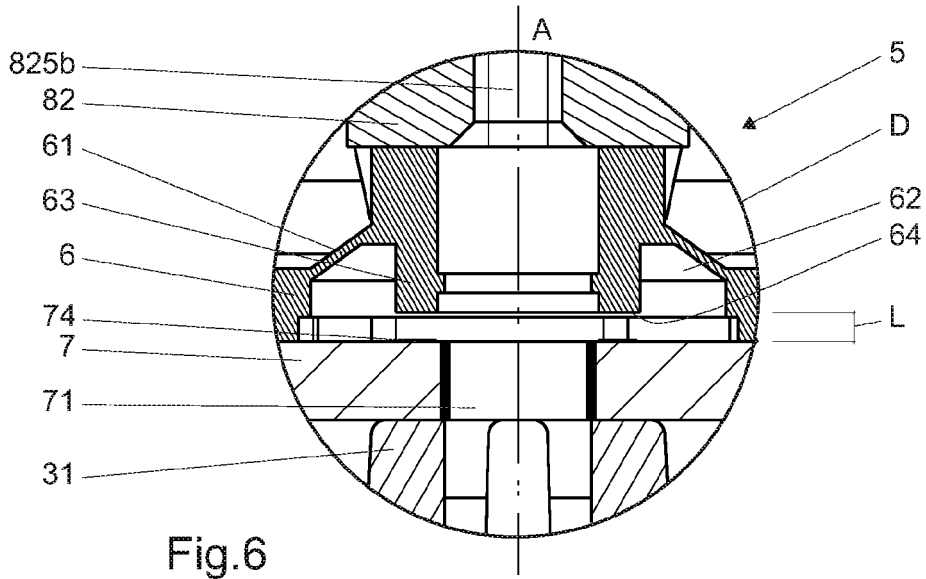

Fig.6

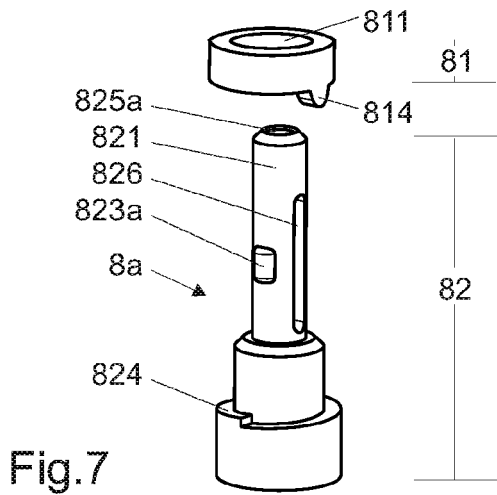

Fig.7

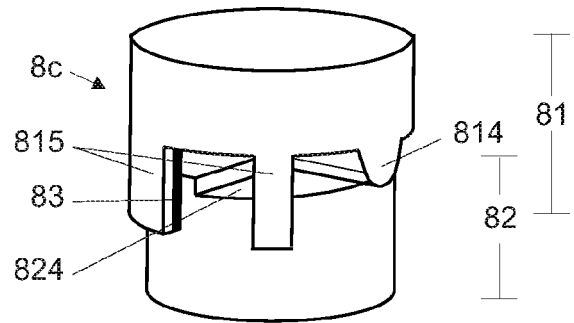

Fig.10

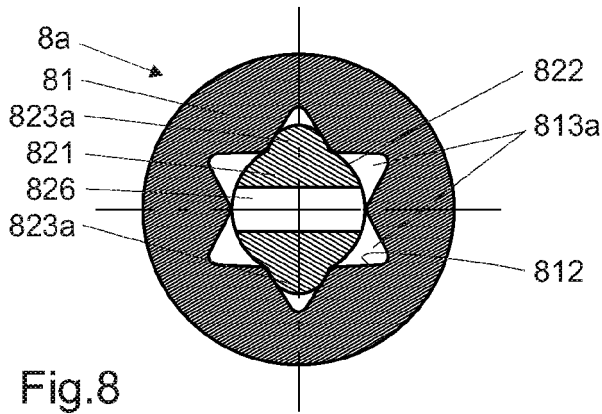

Fig.8

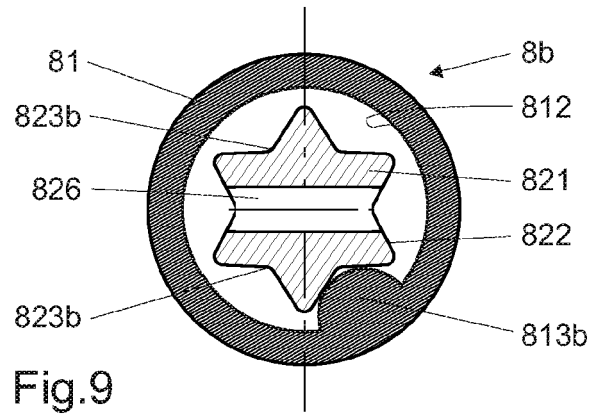

Fig.9

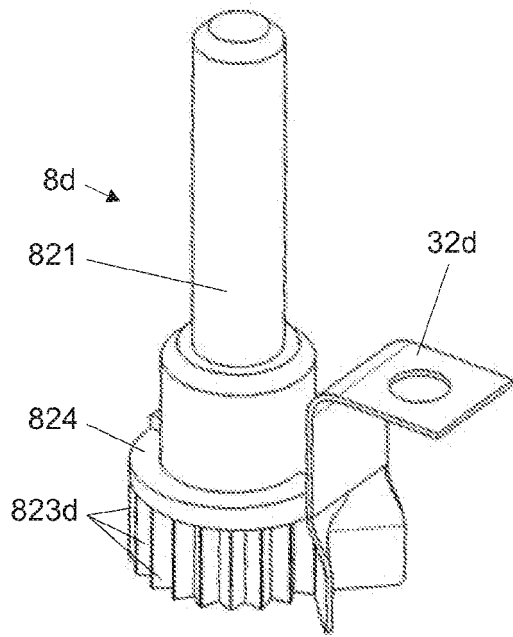

Fig. 11

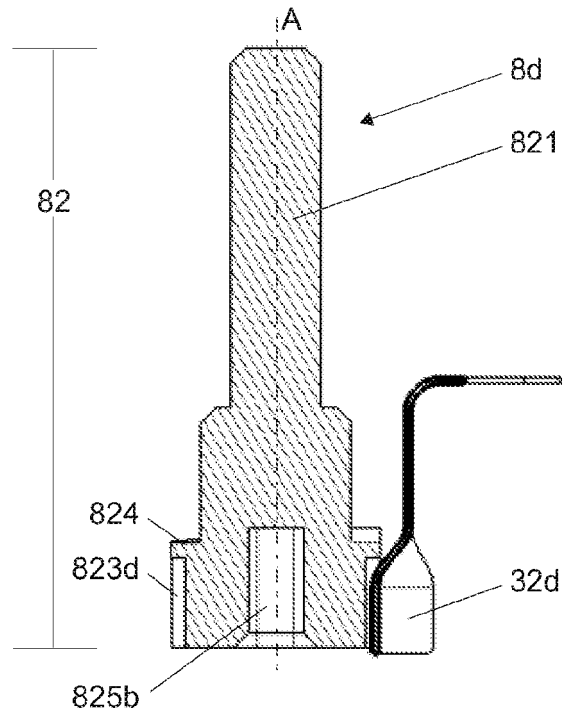

Fig. 12

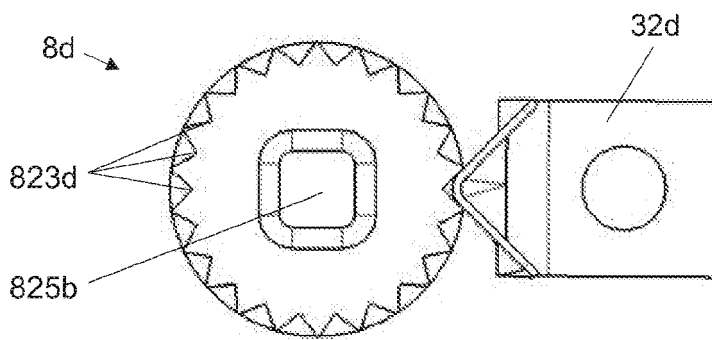

Fig. 13

**REFERENCES CITED IN THE DESCRIPTION**

*This list of references cited by the applicant is for the reader's convenience only. It does not form part of the European patent document. Even though great care has been taken in compiling the references, errors or omissions cannot be excluded and the EPO disclaims all liability in this regard.*

**Patent documents cited in the description**

- US 2013220789 A [0005]
- US 2018074587 A1 [0007]
- US 2008316064 A [0006]