



⑫

## EUROPEAN PATENT SPECIFICATION

④⑤ Date of publication of patent specification :  
**16.12.92 Bulletin 92/51**

⑤① Int. Cl.<sup>5</sup> : **F24F 13/00**, F24F 7/08,  
F04D 29/66, F24F 7/007

②① Application number : **89304889.2**

②② Date of filing : **15.05.89**

---

⑤④ **Acoustic fresh air ventilator.**

---

③⑩ Priority : **17.05.88 GB 8811603**

④③ Date of publication of application :  
**23.11.89 Bulletin 89/47**

④⑤ Publication of the grant of the patent :  
**16.12.92 Bulletin 92/51**

⑧④ Designated Contracting States :  
**AT BE CH DE ES FR GB GR IT LI LU NL SE**

⑤⑥ References cited :  
**FR-A- 2 505 416**  
**US-A- 3 125 286**  
**US-A- 3 789 747**

⑦③ Proprietor : **DIFFUSION ENVIRONMENTAL  
SYSTEMS LIMITED**  
**Diffusion House Central Avenue**  
**East Molesey Surrey (GB)**

⑦② Inventor : **Howard, David Arthur**  
**11 Windmill Drive**  
**Leatherhead Surrey KT22 8PR (GB)**  
Inventor : **Grimmer, Peter Roy**  
**13 Barbara Close**  
**Shepperton Middlesex (GB)**

⑦④ Representative : **Beresford, Keith Denis Lewis**  
**et al**  
**BERESFORD & Co. 2-5 Warwick Court High**  
**Holborn**  
**London WC1R 5DJ (GB)**

**EP 0 342 899 B1**

---

Note : Within nine months from the publication of the mention of the grant of the European patent, any person may give notice to the European Patent Office of opposition to the European patent granted. Notice of opposition shall be filed in a written reasoned statement. It shall not be deemed to have been filed until the opposition fee has been paid (Art. 99(1) European patent convention).

---

## Description

The present invention relates to an acoustic fresh air ventilator suitable for ventilating a compartment.

Acoustic fresh air ventilators commonly provide a means of introducing fresh air into a compartment through a compartment wall and can include a means for extracting stale air from the compartment. References hereafter to "wall" when relating to a compartment is meant to include the ceiling or even the floor of the compartment. Known acoustic fresh air ventilators often include a fan for forced ventilation. In one such ventilator there is provided a motor driven fan mounted within a box or housing whose sides are provided with a layer of acoustic material, the fan being fixed to one wall and the box is so designed as to be mounted in a hole in a wall of the compartment to be ventilated. There are several disadvantages in this arrangement. Firstly, to obtain useful ventilation, the fan must be about 90mm wide by about 180mm in diameter, resulting in a box of about 220mm by 140mm by 250mm. This allows for acoustic lagging on the interior of the sides of the box of about 15mm thick. The hole to accommodate the box in the wall is necessarily of a similar size to that of the box which results in a hole which is structurally undesirable and may be aesthetically unappealing.

United States Patent No 3125286 in the name of G J Saunders discloses a ventilator system designed to reduce the transmission of noise and vibrations from the ventilator fan to the ventilator housing. However, the Sanders ventilator requires fan supports in the form of struts between the fan and the corners of the ventilator housing in order to securely support the fan in position in the housing.

It is one object of the invention to reduce the size of the hole required in the wall of the compartment. A further object of the invention is to improve the acoustic performance of the ventilator.

The acoustic fresh air ventilator according to the invention comprises a box mountable to a compartment wall, one or more fans within the box with suitable conduits from the fan(s) to the outside of the box, the box being packed with acoustic material, wherein the or each fan is unattached to the box and is retained and supported in a predetermined position within the box by the acoustic material.

By mounting the box inside the compartment and fitting the or each extending ducting element through the wall, the size of the hole through the wall need be no more than one standard brick size. Furthermore, the box can be provided with thicker acoustic lining than the known ventilator because there is no requirement to limit the box size relative to the hole through the wall. This results in a substantial noise reduction.

In order to even further reduce fan noise, it has been found advantageous to locate the or each fan unmounted to the box but merely retained in the box

by the acoustic packing material.

The acoustic material is suitably a mineral wool such as rockwool and is contained or structured in such a way that internal conduits between the box sides and fan(s) are formed by shaping the wool packing.

Preferably this acoustic material is in several pieces or pads so that the pieces or pads can be easily removed and replaced to access the fan(s).

The or each external ducting element is preferably formed as a perforated tube surrounded by acoustic material which is in turn surrounded by a further tube.

One embodiment of the invention will now be described with reference to the accompanying drawings in which:

Figure 1 is a plan view of an acoustic ventilator according to the invention, and

Figure 2 is a cross-section taken at A-A of the ventilator of Figure 1.

In the drawings, there is shown an acoustic ventilator with a six sided box 1. The size of the box containing two fans is 603mm by 405mm by 205mm. One side 3 of the box is a lid which may be riveted, bolted or hinged to one or more of the other sides. The box is provided with wall mounting means comprising brackets 4 for mounting the box to a wall 5.

Within the box are two identical motorised centrifugal fans 8 and 10. Suitably these fans are centrifugal fans with single side inlets 12 and 14 respectively. The fans in the embodiment have a capacity of 86 m<sup>3</sup>/h, the fans run up to 2300 rpm and have a self noise level of 51 dBA. The outlets 16 and 18 are substantially square in cross-section and vent into internal conduits 20, 22 which are formed as will be described below within sealed rockwool pads. The fan inlets 24, 26 are also formed within rockwool pads. The fans remain unbolted to the box and are merely located by the acoustic packing within the box. Cabling 28 from the fans extends to an external control either remote or mounted on the exterior of the box. Clearly however, the fan control may be mounted in a suitable place in the box or partially in the box and partially without the box on the lid 3.

The forming of conduits 20, 22, 24 and 26 within the acoustic packing is achieved in the case of conduits 20 and 26 by providing a base liner pad 30 of rockwool enclosed in a pad of nylon or pervious fibre glass material. This pad is suitably strengthened by glue or an epoxy resin to make the pad rigid and to keep conduits 20 and 26 in a predetermined form. A second pad 32 forms one side 34 of conduit 24 and part of walls 33 of conduit 22. Further pads 36, 38 and 40 form the remaining parts of conduits 22 and 24. In this way, the internal conduits are formed without metal and of acoustic material. The padding material prevents the rockwool from migrating within the box. The rockwool used is a heavy density material of 200

kg/m<sup>3</sup>. Any space within the box not occupied by conduits, the fans, or associated electrical elements is therefore filled with acoustic packing which around the fans is generally much thicker than that provided in known prior art assemblies.

Externally, the box has an inlet ducting element 42 and an outlet ducting element 44 formed from metal or plastic external tubes 46 and 46' with perforated aluminium internal tubes 48 and 48'. Between the external and internal tubes is more acoustic material 50 and 50'. Flexible tubes can be joined to ducting elements 42 and 44 particularly when the ventilator is required for ceiling location.

The ducting elements are mounted to the box as close together as acoustically desirable. The larger inlet element 42 with an external diameter of about 100mm is spaced about 25mm from the smaller outlet element 44 which has an external diameter of about 75mm. The resulting hole 70 defined by wall surfaces 71, 72 need only be about 200mm by 100mm which is within a standard sized building brick of about 225mm by 100mm.

To ensure the size of this hole, the centre 45 of element 44 is offset from centre 9 of the outlet of fan 8. This is necessary due to the near abutment of fan 8 with fan 10. The misalignment of centres 9 and 45 is not deleterious due to the spacing of fan 8 from its box sides by pad 30. Some improvement in misalignment could be achieved by rotating fan 10 through 180 degrees and venting conduit 22 through another side wall. Equally a different handed fan could replace fan 10. The chosen configuration has been chosen for simplicity and acoustic performance.

A further external ducting element 52 is mounted to the box at the outlet of conduit 22 which may be used for coupling the ventilator to an air conditioning unit shown diagrammatically at 60. In this way, conduit 22 communicates directly with the air conditioning unit. Conduit 24 terminates in a perforated plate or area 54 in one side of the box 1.

In a modified packing arrangement the conduits 20, 22, 24 and 26 are cast in two blocks forming the whole of the acoustic packing for the box.

The ventilator of the invention provides a simple but convenient method of introducing fresh air and extracting stale air into and from a compartment without the need to provide a large hole in a wall of the compartment. The acoustic performance is extremely good due to the "floating" of the fan(s) in the ventilator box or housing, without the fan(s) being mounted by bolting or the like to the box. The opportunity has been taken in the embodiment of the invention to eliminate metal conduits within the box or housing which reduces the cost of assembly, manufacture and again improves the acoustic performance.

## Claims

1. A ventilator comprising a box having an inlet port and an outlet port, a motorised fan unit having an inlet port and an outlet port disposed in the box, and sound insulating material which packs the box and surrounds and supports the fan unit which is otherwise unsupported, inlet and outlet ducts being formed through the packing material between the inlet ports of the box and fan unit and the outlet ports of the fan unit and box.
2. A ventilator according to claim 1, wherein the acoustic material is a heavy density mineral wool.
3. A ventilator as claimed in claim 1 or 2, wherein the acoustic material is contained in a plurality of shaped pads.
4. A ventilator as claimed in any preceding claim, wherein the box is adapted to be mounted on a wall, at least one of the inlet and outlet ports of the box communicating with a ducting element mounted to the box and projecting therefrom for extension through the wall.
5. A ventilator according to claim 4, wherein the ducting element is formed with a perforate tube defining the air passage way, the tube being surrounded by acoustic material which is in turn surrounded by a further tube.
6. A ventilator as claimed in any preceding claim, and having a further such fan unit similarly mounted in the box.
7. A ventilator according to any preceding claim and an air conditioning unit coupled together.

## Patentansprüche

1. Ein Gebläse mit einem Kasten, der einen Einlaßanschluß und einen Auslaßanschluß aufweist, einer in dem Kasten angeordneten motorbetriebenen Ventilatoreinheit mit einem Einlaßanschluß und einem Auslaßanschluß, und Schallisolationmaterial, das den Kasten füllt und die Ventilatoreinheit, die sonst ungestützt ist, umgibt und stützt, wobei durch das Füllmaterial zwischen den Einlaßanschlüssen des Kastens und der Ventilatoreinheit und den Auslaßanschlüssen der Ventilatoreinheit und des Kastens Einlaß- und Auslaß-Leitungen gebildet sind.
2. Gebläse nach Anspruch 1, wobei das Akustikmaterial hochdichte Mineralwolle ist.

- |    |   |         |   |
|----|---|---------|---|
| 3. | Gebläse nach Anspruch 1 oder 2, wobei das Akustikmaterial in einer Vielzahl von geformten Kissen enthalten ist.   |         |   |
| 4. | Gebläse nach einem der vorhergehenden Ansprüche, wobei der Kasten zur Befestigung an einer Wand angepaßt ist und mindestens einer der Einlaß- und Auslaßanschlüsse des Kastens mit einem an dem Kasten angebrachten und, um sich durch die Wand zu erstrecken, von ihm weggehenden Leitungselement in Verbindung steht. | 5<br>10 | dans lequel l'élément de conduite comprend un tube perforé délimitant un passage de circulation d'air, le tube étant entouré par un matériau acoustique qui est lui-même entouré d'un autre tube. |
| 5. | Gebläse nach Anspruch 4, wobei das Leitungselement aus einer gelochten Röhre, die den Luftweg bestimmt, gebildet ist, wobei die Röhre von Akustik-Material umgeben ist, das wiederum von einer weiteren Röhre umgeben ist.  | 15      | 6. Ensemble de ventilation selon l'une quelconque des revendications précédentes et comportant un autre ventilateur monté de la même manière dans le coffret.                                     |
| 6. | Gebläse nach einem der vorhergehenden Ansprüche mit einer weiteren solchen Ventilatereinheit, die in dem Kasten ähnlich angebracht ist.   | 20      | 7. Ensemble de ventilation selon l'une quelconque des revendications précédentes et unité de conditionnement d'air accouplés ensemble.  |
| 7. | Gebläse nach einem der vorhergehenden Ansprüche sowie eine mit diesem verbundene Klimaanlageeinheit.  | 25      |   |

### Revendications

- |    |  |                |
|----|--|----------------|
| 1. | Ensemble de ventilation comprenant un coffret avec une ouverture d'entrée et une ouverture de sortie, un ventilateur actionné par un moteur comprenant une ouverture d'entrée et une ouverture de sortie, placé à l'intérieur du coffret, et un matériau d'insonorisation garnissant le coffret qui entoure et supporte le ventilateur, ce dernier n'ayant aucun autre support, des conduites d'entrée et de sortie étant formées à travers le matériau de garnissage entre les ouvertures d'entrée du coffret et du ventilateur et entre les ouvertures de sortie du ventilateur et du coffret. | 30<br>35<br>40 |
| 2. | Ensemble de ventilation selon la revendication 1, dans lequel le matériau acoustique est une laine minérale à haute densité.   | 45             |
| 3. | Ensemble de ventilation selon la revendication 1 ou 2, dans lequel le matériau acoustique est contenu dans plusieurs blocs profilés.   | 50             |
| 4. | Ensemble de ventilation selon l'une quelconque des revendications précédentes, dans lequel le coffret est conçu pour un montage mural et au moins une des ouvertures d'entrée et de sortie du coffret communique avec un élément de conduite fixé au coffret et en saillie pour traverser le mur.  | 55             |
| 5. | Ensemble de ventilation selon la revendication 4,  |                |

FIG. 1.

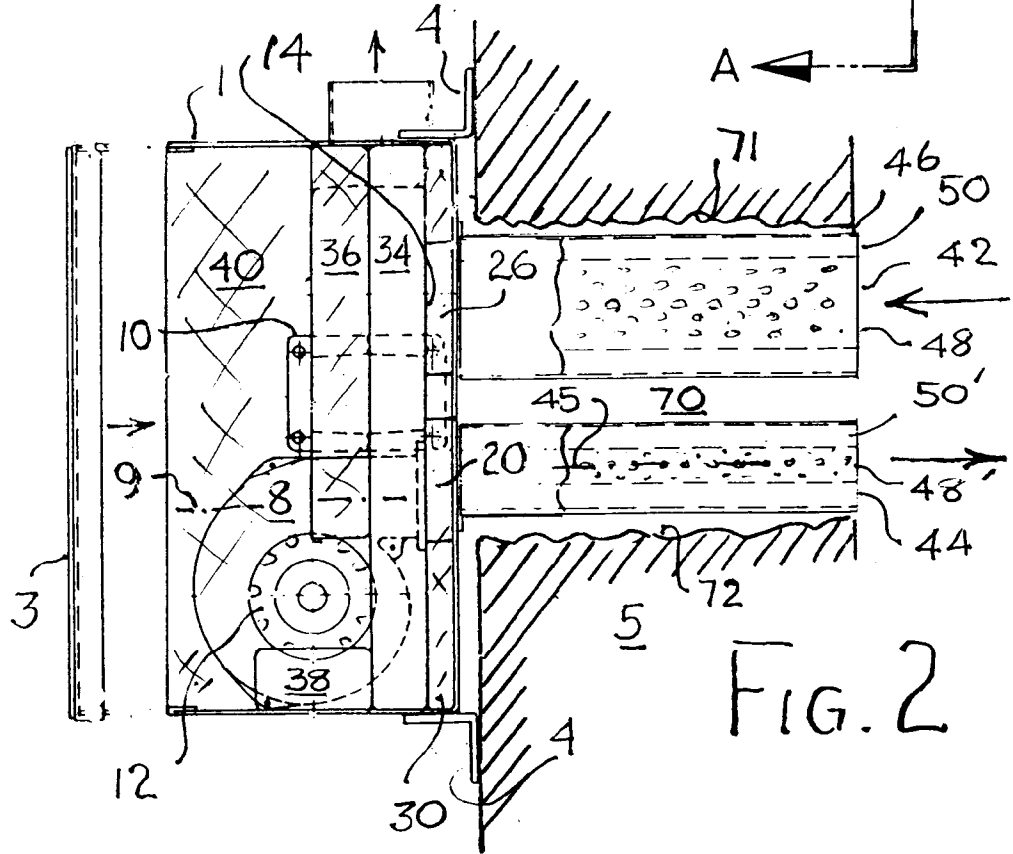
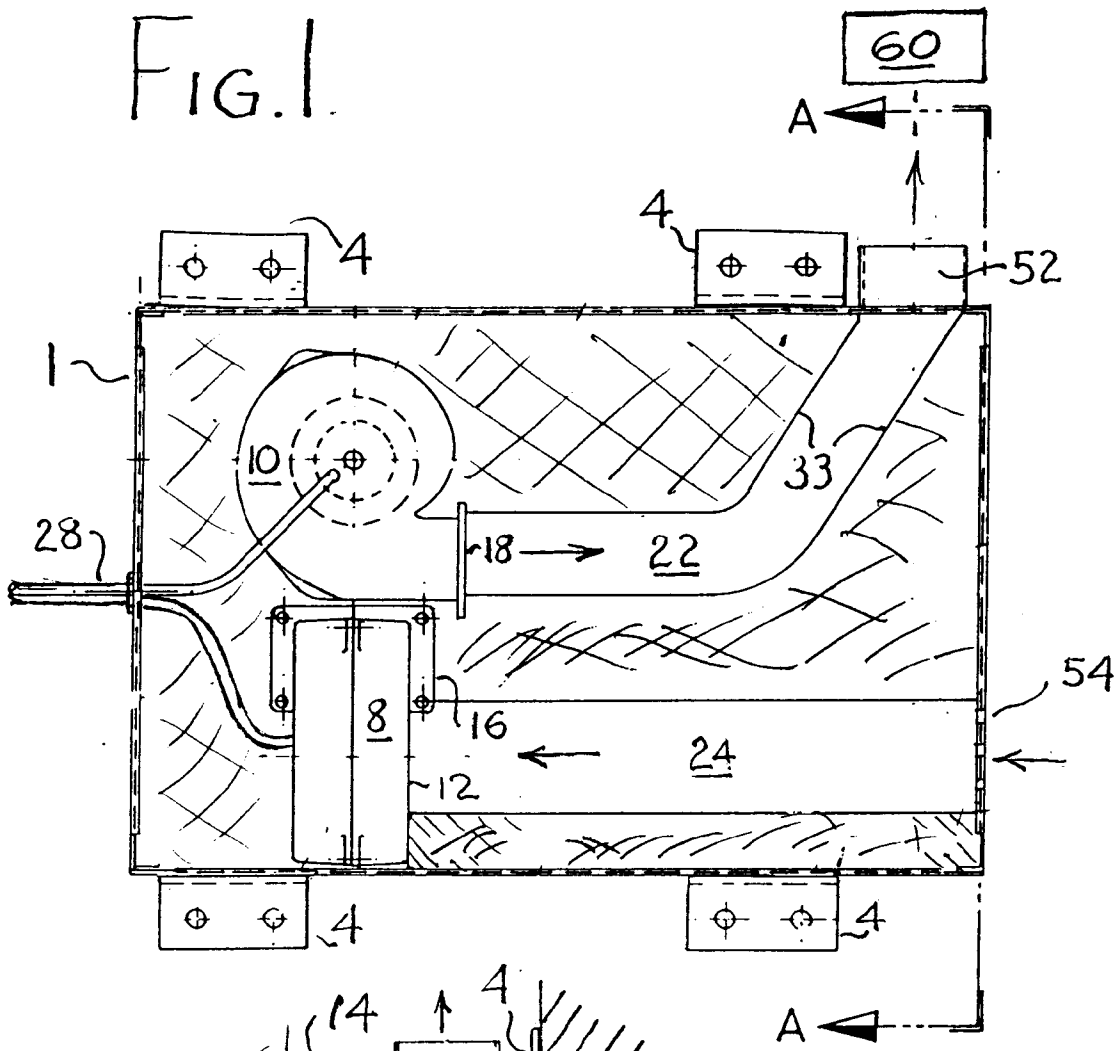

FIG. 2