



(72) BUNSCHOTEN, GERRIT KLAAS, NL

(72) PRITCHARD, NORMAN JASON, NL

(71) UNILEVER PLC, GB

(51) Int.Cl.<sup>6</sup> B05B 11/00, B65D 51/28, G01F 11/08

(30) 1997/12/15 (97203930.9) EP

(54) **DISPOSITIF DE DOSAGE DE CONCENTRE POUR  
ATOMISEURS RECHARGEABLES**

(54) **CONCENTRATE DOSING DEVICE FOR REFILLABLE SPRAY  
DISPENSERS**

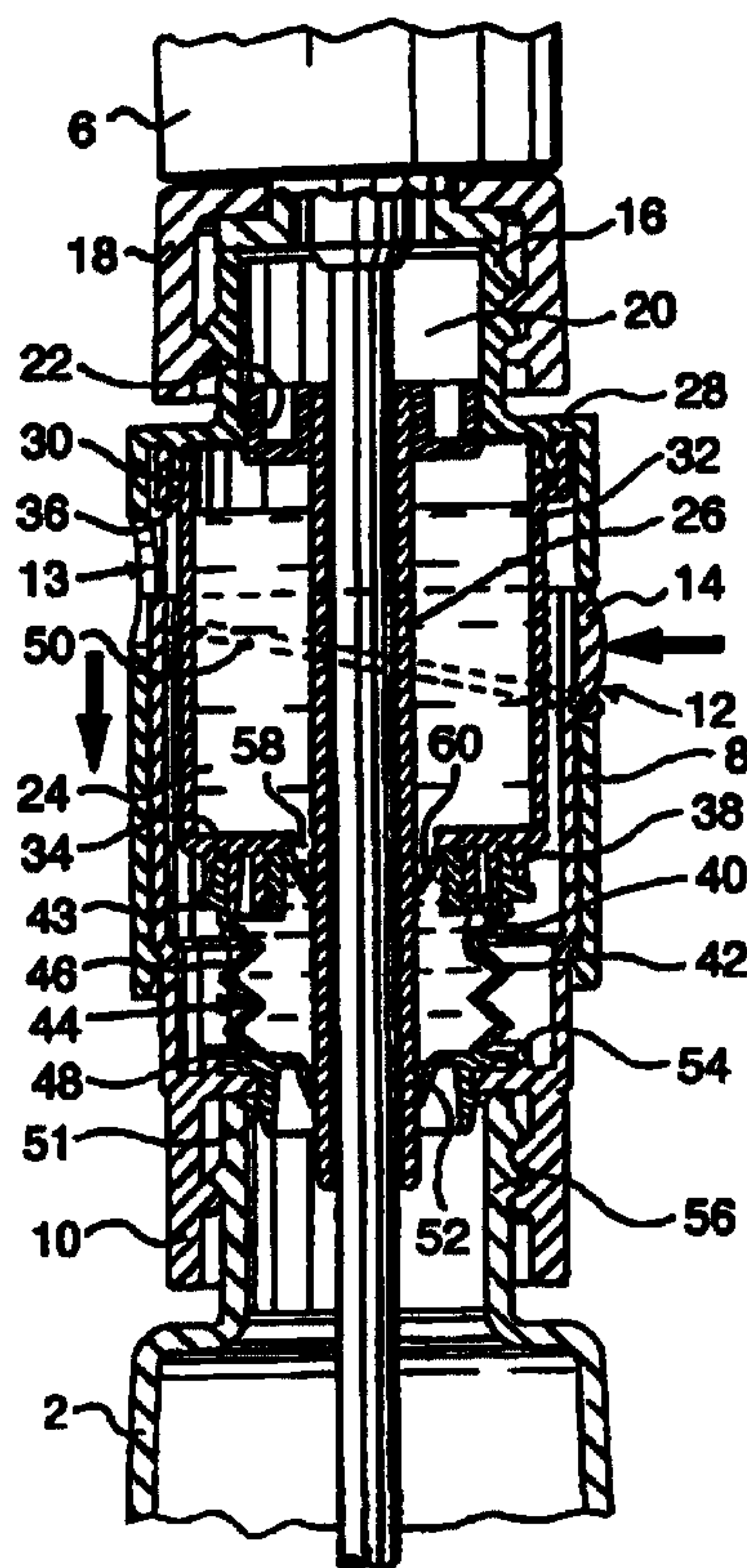

(57) L'invention concerne un dispositif permettant de doser une quantité prédéterminée de concentré dans un atomiseur (2). Ce dispositif, qui peut être inséré entre une tête de pulvérisation (6) et l'atomiseur (2), comprend un compartiment réservoir (24) pouvant recevoir une quantité prédéterminée de concentré, et un compartiment de dosage (44) associé audit compartiment réservoir (24). Le concentré peut être transféré dans le compartiment de dosage (44), lequel a une forme permettant de doser une quantité prédéterminée de concentré à injecter dans l'atomiseur (2).

(57) The invention relates to a device for dosing a predetermined amount of concentrate into a spray dispenser (2), said device being insertable between a spray head (6) and the spray dispenser (2), the device comprising: a reservoir chamber (24) for storing a predetermined amount of concentrate; a dosing chamber (44) associated with said reservoir chamber (24), wherein concentrate is transferable into the dosing chamber (44) having such a form as to be able to dose a predetermined amount of concentrate into the spray dispenser (2).

**PCT**WORLD INTELLECTUAL PROPERTY ORGANIZATION  
International Bureau

## INTERNATIONAL APPLICATION PUBLISHED UNDER THE PATENT COOPERATION TREATY (PCT)

|  |  |   |
|--|--|---|
| <p>(51) International Patent Classification <sup>6</sup> :<br/><b>B05B 11/00, B65D 51/28, G01F 11/08</b></p>   | <p><b>A1</b></p>   | <p>(11) International Publication Number: <b>WO 99/30836</b><br/>(43) International Publication Date: 24 June 1999 (24.06.99)</p> |
| <p>(21) International Application Number: PCT/EP98/07546<br/>(22) International Filing Date: 19 November 1998 (19.11.98)<br/>(30) Priority Data:<br/>97203930.9 15 December 1997 (15.12.97) EP<br/>(71) Applicant (for all designated States except AU BB CA CY GB GD GH IE KE LK LS MN MW NZ SD SG SZ TT UG): UNILEVER N.V. [NL/NL]; Weena 455, NL-3013 AL Rotterdam (NL).<br/>(71) Applicant (for AU BB CA CY GB GD GH IE KE LK LS MN MW NZ SD SG SZ TT UG only): UNILEVER PLC [GB/GB]; Unilever House, Blackfriars, London EC4P 4BQ (GB).<br/>(72) Inventors: BUNSCHOTEN, Gerrit, Klaas; Diversey Lever, Maarssenbroeksedijk 2, NL-3606 AN Maarssen (NL). PRITCHARD, Norman, Jason; Maarssenbroeksedijk 2, NL-3606 AN Maarssen (NL).<br/>(74) Agent: ROSEN JACOBSON, Frans, L., M.; Unilever N.V., Patent Dept., P.O. Box 137, NL-3130 AC Vlaardingen (NL).</p> | <p>(81) Designated States: AL, AM, AT, AU, AZ, BA, BB, BG, BR, BY, CA, CH, CN, CU, CZ, DE, DK, EE, ES, FI, GB, GD, GE, GH, GM, HR, HU, ID, IL, IS, JP, KE, KG, KP, KR, KZ, LC, LK, LR, LS, LT, LU, LV, MD, MG, MK, MN, MW, MX, NO, NZ, PL, PT, RO, RU, SD, SE, SG, SI, SK, SL, TJ, TM, TR, TT, UA, UG, UZ, VN, YU, ZW, ARIPO patent (GH, GM, KE, LS, MW, SD, SZ, UG, ZW), Eurasian patent (AM, AZ, BY, KG, KZ, MD, RU, TJ, TM), European patent (AT, BE, CH, CY, DE, DK, ES, FI, FR, GB, GR, IE, IT, LU, MC, NL, PT, SE), OAPI patent (BF, BJ, CF, CG, CI, CM, GA, GN, GW, ML, MR, NE, SN, TD, TG).</p> <p><b>Published</b><br/>With international search report.<br/>Before the expiration of the time limit for amending the claims and to be republished in the event of the receipt of amendments.</p> |   |

**(54) Title:** CONCENTRATE DOSING DEVICE FOR REFILLABLE SPRAY DISPENSERS**(57) Abstract**

The invention relates to a device for dosing a predetermined amount of concentrate into a spray dispenser (2), said device being insertable between a spray head (6) and the spray dispenser (2), the device comprising: a reservoir chamber (24) for storing a predetermined amount of concentrate; a dosing chamber (44) associated with said reservoir chamber (24), wherein concentrate is transferable into the dosing chamber (44) having such a form as to be able to dose a predetermined amount of concentrate into the spray dispenser (2).

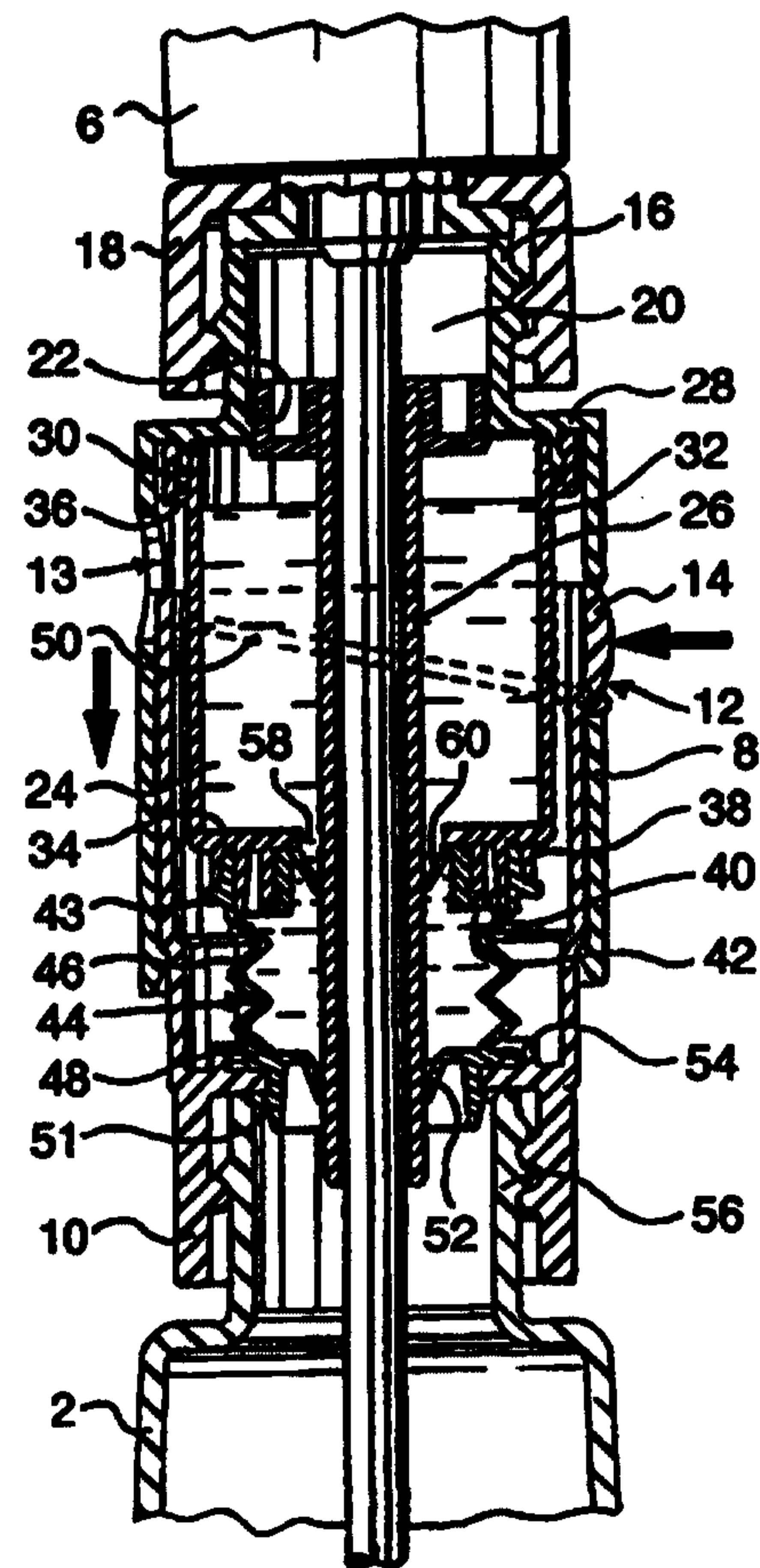

WO 99/30836

IN 17 0000  
PCT/EP98/07546

1

## CONCENTRATE DOSING DEVICE FOR REFILLABLE SPRAY DISPENSERS

Field of the invention

The present invention relates to a device for dosing a  
5 predetermined amount of concentrate into a spray dispenser,  
to a spray assembly comprising such a device and to a  
method for dosing a liquid concentrate into a dispenser.

Background of the invention

10 The use of manually operable spray containers, especially  
spray bottles, for dispensing reagents such as water,  
detergent cleaners, de-icers, insecticides and the like, as  
an alternative to environmentally harmful aerosols, are  
well known.

15 The most spray dispenser bottles currently on the market,  
are pre-filled with a chemical reagent and sold ready to  
use.

Once the contents of these spray dispenser bottles have  
been used up, these spray dispenser bottles are often  
20 thrown away despite the fact that they mostly remain fully  
functional.

Devices insertable between a spray head and a dispenser  
container are known, and are described in US 5,529,216,  
EP-A-0 606 672, and DE-35 35986 for example.

25 Although these devices and systems are functional, they are  
awkward to operate. Furthermore operation of these devices  
often leads to overdosing of the concentrate, and an  
uneconomical operation.

It is an object of the present invention to provide an  
30 improved device for dosing concentrate into a spray  
dispenser.

(A) In addition, EP-A-795,267 discloses a device for  
dosing a predetermined amount of liquid into a spray  
dispenser, said device being insertable between a spray  
head and the spray dispenser

AMENDED SHEET

### Definition of the invention

According to a first aspect of the present invention, there is provided a device for dosing a predetermined amount of concentrate into a spray dispenser, said device being  
 5 insertable between a spray head and the spray dispenser, the device comprising:

- a reservoir chamber for storing a predetermined amount of concentrate;
- a dosing chamber associated with said reservoir chamber,  
 10 wherein concentrate is transferable into the dosing chamber from the reservoir chamber, said dosing chamber having such a form as to be able to dose a predetermined amount of concentrate into the spray dispenser,

insert  
page 2a

According to a second aspect of the present invention there  
 15 is provided an assembly comprising a spray head, a device according to the above, and a container, preferably being a spray dispenser bottle.

According to a third aspect of the present invention there is provided a process for dosing a predetermined amount of  
 20 concentrate into a spray dispenser comprising the steps of:

- arranging the device above between a spray dispenser head and a spray dispenser container;

- displacing the reservoir <sup>chamber</sup> with respect to the dosing chamber so that concentrate flows from the reservoir <sup>chamber</sup> into  
 25 the dosing chamber; and/or <sup>chamber</sup>
- displacing the reservoir <sup>chamber</sup> with respect to the dosing chamber so that the concentrate flows from the dosing chamber into the spray bottle.

### 30 Detailed description of the invention

The device of the present invention enables a user to transfer a predetermined amount of concentrate from the reservoir chamber into the dosing chamber, wherefrom this concentrate is dosed, when desired, into the dispenser in

M 17 02 00

- 2a -

Insert on page 2, line 13:

characterised in that the device comprises a first housing part cooperable with a second housing part, wherein the first housing part is releasably securable to a neck of the spray head and wherein the second housing part is releasably securable to a neck of the spray dispenser.

order to mix with the liquid therein to provide a use solution.

Accordingly, the concentration of the use solution can be adjusted when required and furthermore, when the use  
5 solution is finished, the dispenser is merely refilled with liquid, such as water, whereafter concentrate can be dosed therein by the device.

The dosing chamber is preferably transformable in shape between a first volume and a second volume, wherein the  
10 first volume is greater than the second volume, and most preferably, the dosing chamber has a concertina like form in order to efficiently dose a desired amount of concentrate into the dispenser.

The reservoir chamber is preferably displaceable with  
15 respect to the dosing chamber in order to transform said dosing chamber between its first and second volume shapes. In order to accurately control the transfer of concentrate between the reservoir chamber and the dosing chamber, valve means can be arranged therebetween.

20 The reservoir chamber and dosing chamber are ~~preferably~~ housed within a first and second housing part, wherein the first housing part is cooperable with the second housing part, and wherein the first housing part is preferably displaceable with respect to the second housing part in  
25 order to effect efficient dosing.

The second housing part is preferably releasably lockable within the first housing part in order to provide extra user control and further prevent over-dosing.

The first housing part is ~~preferably~~ releasably securable  
30 to a neck of a spray head and the second housing part is ~~preferably~~ releasably securable to a neck of a dispenser, in order to provide good utility.

The dosing chamber furthermore preferably comprises valve means for controlling the transfer of concentrate into the spray dispenser therefrom.

In order to further prevent overdosing of the concentrate, 5 the device may comprise securing means for securing the dosing chamber in its second volume shape.

The invention will now be further clarified by way of the following specific description with reference to the accompanying drawings, wherein:

- 10 - figure 1 shows a perspective view of a preferred embodiment of an assembly according to the present invention;
- figures 2-3 show cut away exploded side views through section II-II of figure 1, of a preferred embodiment of a 15 device according to the present invention in working;
  - figure 4 shows a partially cut-away perspective view of part of the embodiment from figure 2, 3; and
  - figure 5-7 show a partially cut-away exploded side views of a further embodiment of a device according to the 20 present invention.

An assembly 1 (figure 1) comprises a spray bottle dispenser 2, a device 4 in the form of a "pump action cartridge" and a spray head 6 having a down tube 9 connected thereto which extends through the cartridge 4 and into the bottle 2.

25 The cartridge 4 comprises a first housing part 8 and a second housing part 10. The first housing part 8 is provided with oppositely arranged circular openings 12 and 13 which co-operate with a locking stub 14 of the second housing part 10 (see further figures 2-4). A "screw" thread 30 50 is arranged on the inner surface of the first housing part 8 between the openings 12, 13.

An upstanding neck part 16 of the first housing part 8 is screwably locked into a cap 18 of the spray head 6, see figures 2 and 3.

A ring section 20 is provided within the neck 16 of the housing 8 wherethrough the down tube 9 extends. At the lower side thereof, the ring section 20 contacts two U-elements in cross-section 22, which together with shoulders 5 28 of the neck 16 form an upper wall of a reservoir chamber 24 (figure 2).

The reservoir chamber 24 is defined by an inner wall 26 extending from the elements 22 downwardly along the down tube 9, side walls 32 extending downwardly to terminate in 10 a reservoir lower wall 34 wherein the side wall 32 are provided at the top end thereof with an outstanding L-section in cross-section 36 which cooperates with depending rim 30 of the outer housing 8.

The lower wall 34 is provided with three extending lips, 15 respectively 38, 40 and 42. The lips 38 and 40 extend from the lower wall 34 to enclose an upstanding rim part 43 of a dosing chamber 44.

An opening 58 is provided in the lower wall 34 of the reservoir 24 next to the inner wall 26 thereof.

20 Valves 60 are arranged between the reservoir 24 and the dosing chamber 44.

The dosing chamber 44 has side walls 46 comprising a plurality of sections foldable like a concertina.

A lower wall 48 of the dosing chamber comprises a locking 25 inverted L-shaped in cross-section rim 51 and valves 52.

Lying L-sections in cross-section 54 of the second housing 10 interlock with the lower wall 48 of the dosing chamber 44.

The second housing part 10 is screwed onto an upstanding 30 neck 56 of the dispenser bottle 2.

The reservoir chamber can typically have a capacity of 20-200 ml depending on the type of application whilst the dosing chamber can typically have a capacity of 1-10 ml. It will of course be clear that the device can be produced to

yield different capacities of the reservoir and dosing chamber in order to meet client's wishes.

After having arranged the device 4 between the spray head 6 and the bottle 2 for the first time (figure 2), the spray head 6 and outer housing 8 can be pushed downwards and rotated about the inner housing 10, by first releasing the locking stub 14 from the opening 12 of the outer housing 8 (figure 2) and subsequently rotateably screwing the outer housing 8 downwards, whereby thread 50 follows the stub 14, so that the latter locks into opening 13, figures 3, 4. On doing so, the reservoir 24 is pushed down which in turn concertinas the dosing chamber 44, whereby the first housing 8 slides down over the sidewalls of the second housing 10 so that L-section 36 of the reservoir chamber 24 comes to rest on the side wall 32 of the second housing part 10 where by the dosing chamber achieves its fully folded form (see figure 3). When using the device for the first time in this manner, the dosing chamber 44 will be empty unless the dosing chamber is pre-filled ready for sale and use, as is preferably the case.

In order to fill the dosing chamber, stub 14 is pushed inwards and released from opening 13, whereafter the outer housing 8 and reservoir 24, are pulled upwards by the user, the first housing 8 being rotated about the second housing 10 by means of thread 50 following stub 14 thereby unfolding the walls of the dosing chamber whereby valves 60 open to allow passage of concentrate in the reservoir chamber 24 to flow into the opening dosing chamber 44.

Upward movement of the outer housing 8 and the reservoir 24 is stopped when the locking stub 14 of the inner housing 10 positions itself again in the opening 12 of the housing 8 to lock itself therein. In this state the dosing chamber 44 is filled with concentrate.

In order to dose the contents of the dosing chamber into the bottle, the housing 8 and reservoir chamber are once again pushed down, whereby the dosing chamber folds down to expel the concentrate out through the valves 52 of the dosing chamber and into the bottle. Since dosage is carefully controlled and the dosing chamber is "locked" in its compressed state, from where it must be physically released before any further dosage is possible, overdosing of the concentrate is prevented.

10 The solution in the bottle itself can be sprayed in the normal manner by operating the spray head 6.

In a second embodiment 60 (figures 5-7) of the device according to the present invention the outer housing 62 is locked in a dosing state, figure 6, wherein the dosing chamber is compressed, by means of firstly releasing the locking stub in the outer housing opening, and then simply pushing the outer housing 62 over the inner housing so that a locking lip 64 on the under side of the outer housing 62 is moved over and locked under a locking rim 66 associated with the inner housing 68, see figure 6. In order to release the outer housing from this position, the outer housing and the inner housing must firstly be screwed off of the neck of the dispenser bottle, as shown in figure 7 whereby the locking lip 64 is released from its locked position (figure 6), since the inner housing 68 shrinks to its normal size on release from the dispenser neck 70. Accordingly overdosing of the concentrate is prevented since in order to discharge the dosing chamber, the device 60 must firstly be removed from the dispenser bottle.

30 In order to re-dose concentrate into the bottle, the above steps need merely be repeated.

The invention is not limited to the above described preferred embodiments, the requested rights are rather determined by the following claims.

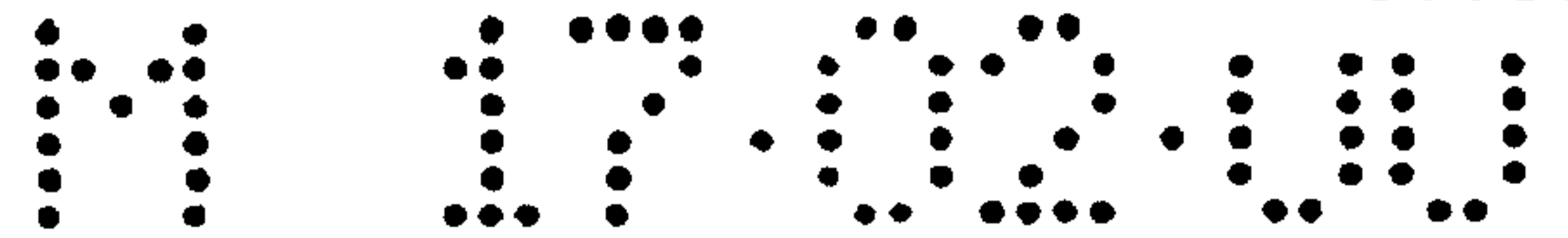

C 7484 (V)

Claims

1. Device (4) for dosing a predetermined amount of concentrate into a spray dispenser (2), said device being insertable between a spray head (6) and the spray dispenser (2), the device comprising:
  - a reservoir chamber (24) for storing a predetermined amount of concentrate;
  - a dosing chamber (44) associated with said reservoir chamber (24), wherein concentrate is transferable into the dosing chamber from the reservoir chamber, said dosing chamber from the reservoir chamber, said dosing chamber (44) having such a form as to be able to dose a predetermined amount of concentrate into the spray dispenser (2), characterised in that the device comprises a first housing part (8) cooperable with a second housing part (10), wherein the first housing part is releasably securable to a neck (18) of the sprayhead (6) and wherein the second housing part (10) is releasably securable to a neck (56) of the spray dispenser (2).
2. Device according to claim 1, wherein the dosing chamber (44) is transformable in shape between a first volume and a second volume, wherein the first volume is greater than the second volume.
3. Device according to claim 1 or 2, wherein the dosing chamber (44) has a concertina like form.
4. Device according to any of the previous claims, wherein the reservoir chamber (24) is displaceable with respect to the dosing chamber (44).

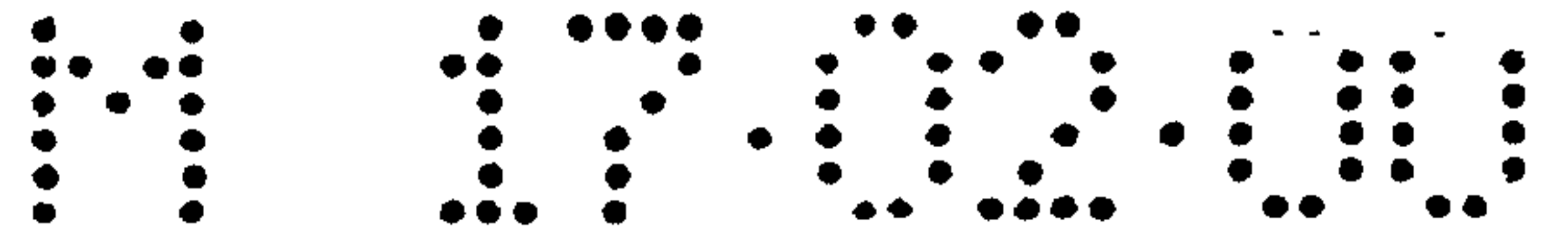

- 2 -

5. Device according to any of the previous claims, wherein the dosing chamber (44) and the reservoir chamber (24) are separated by displaceable valve means (60), displaceable between an open position wherein transfer of concentrate between the reservoir chamber and the dosing chamber is allowable, and a closed position wherein transfer of concentrate between the two chambers is cut off.
6. Device according to claim 5, wherein the chambers are lockable in the closed position.
7. Device according to any of the previous claims, wherein the first housing part (8) is displaceable with respect to the second housing part (10).
8. Device according to claim 7, wherein the second housing part (10) is releasably lockable within the first housing part (8).
9. Device according to any of the previous claims, wherein the dosing chamber (44) further comprises valve means (52) for controlling the transfer of concentrate into the spray dispenser (2) from the dosing chamber (44).
10. Device according to any of the previous claims furthermore comprising securing means (64; 66) for securing the dosing chamber (44) in its second volume shape.
11. Assembly (1) comprising a spray head (6), a device (4) according to any of the previous claims, and a container, preferably being a spray dispenser bottle (2).

M 17.02.00

- 3 -

12. Assembly according to claim 11, wherein the container comprises more than one neck-like opening wherein the device (4) is insertable.
13. Process for repeatedly dosing a predetermined amount of concentrate into a spray dispenser (2), comprising the steps of:
  - arranging a device (4) according to any of the claims 1-10 between a spray dispenser head (6) and a spray dispenser container (2);
  - displacing the reservoir chamber (24) with respect to the dosing chamber (44) so that the concentrate flows from the reservoir chamber into the dosing chamber;
  - and/or
  - displacing the reservoir chamber (24) with respect to the dosing chamber (44) so that the concentrate flows from the dosing chamber into the spray bottle.
14. Use of a device according to any of the claims 1-10 to repeatably dose a predetermined amount of concentrate into a spray dispenser bottle (2).

Fig. 1.

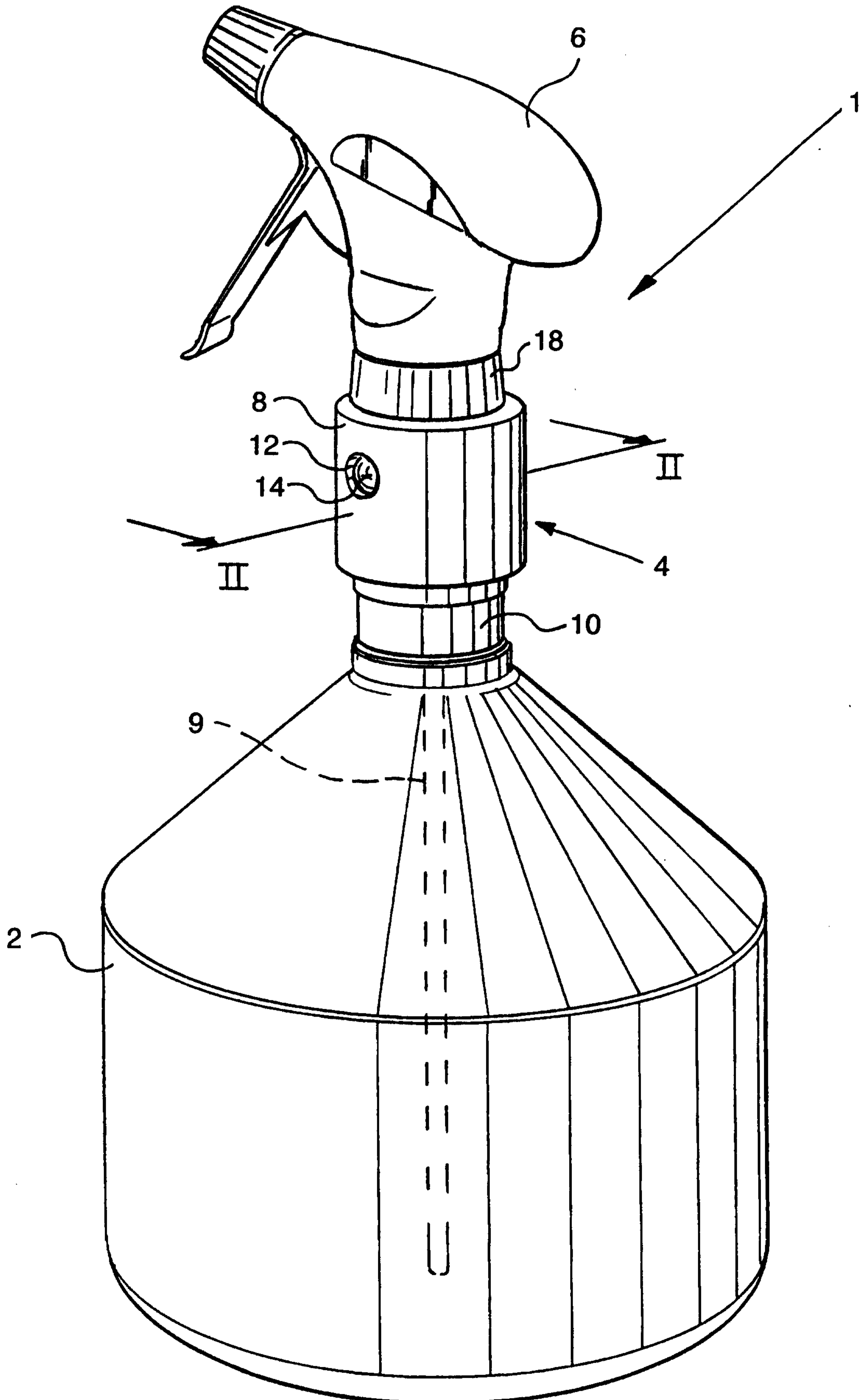

Fig.2.

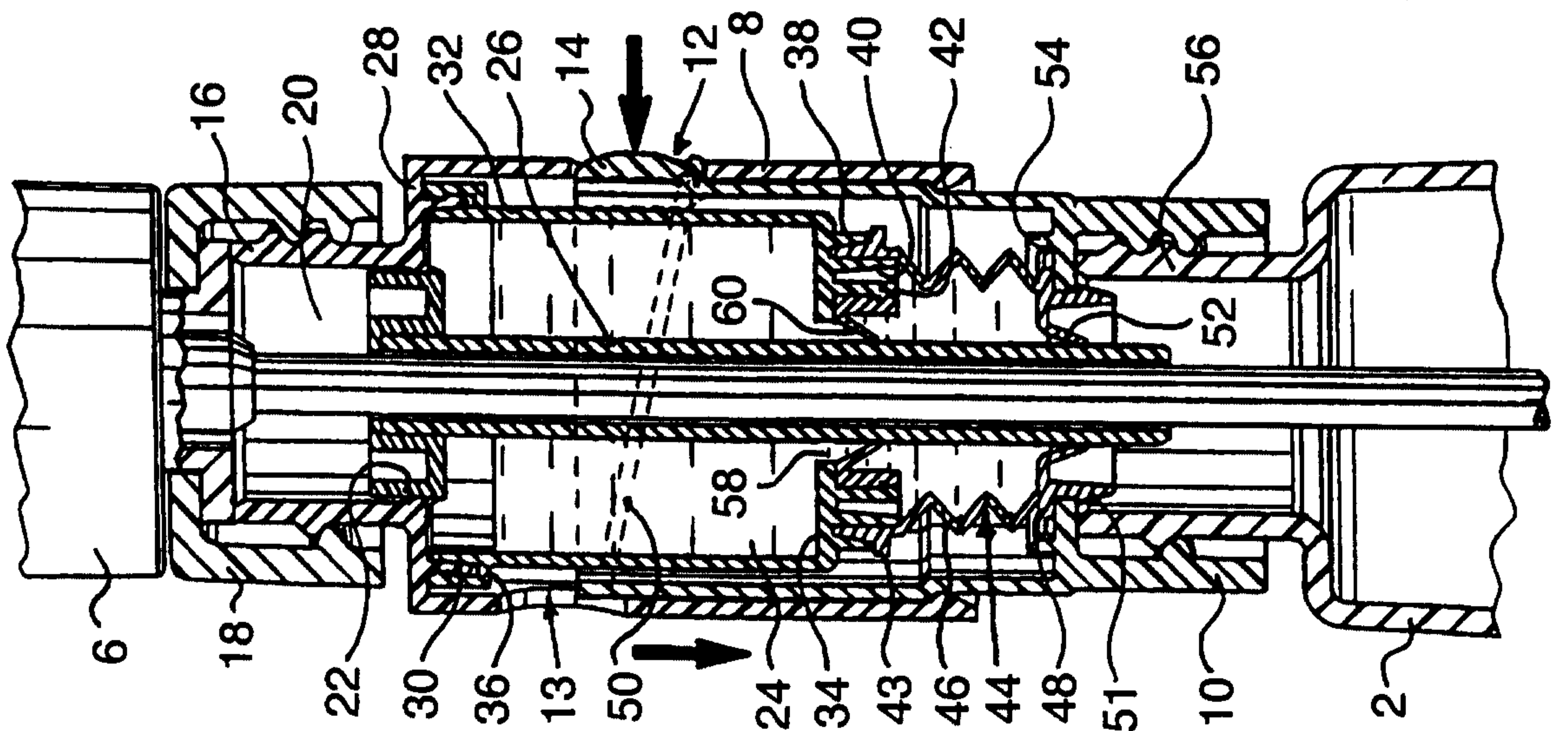

Fig.3.

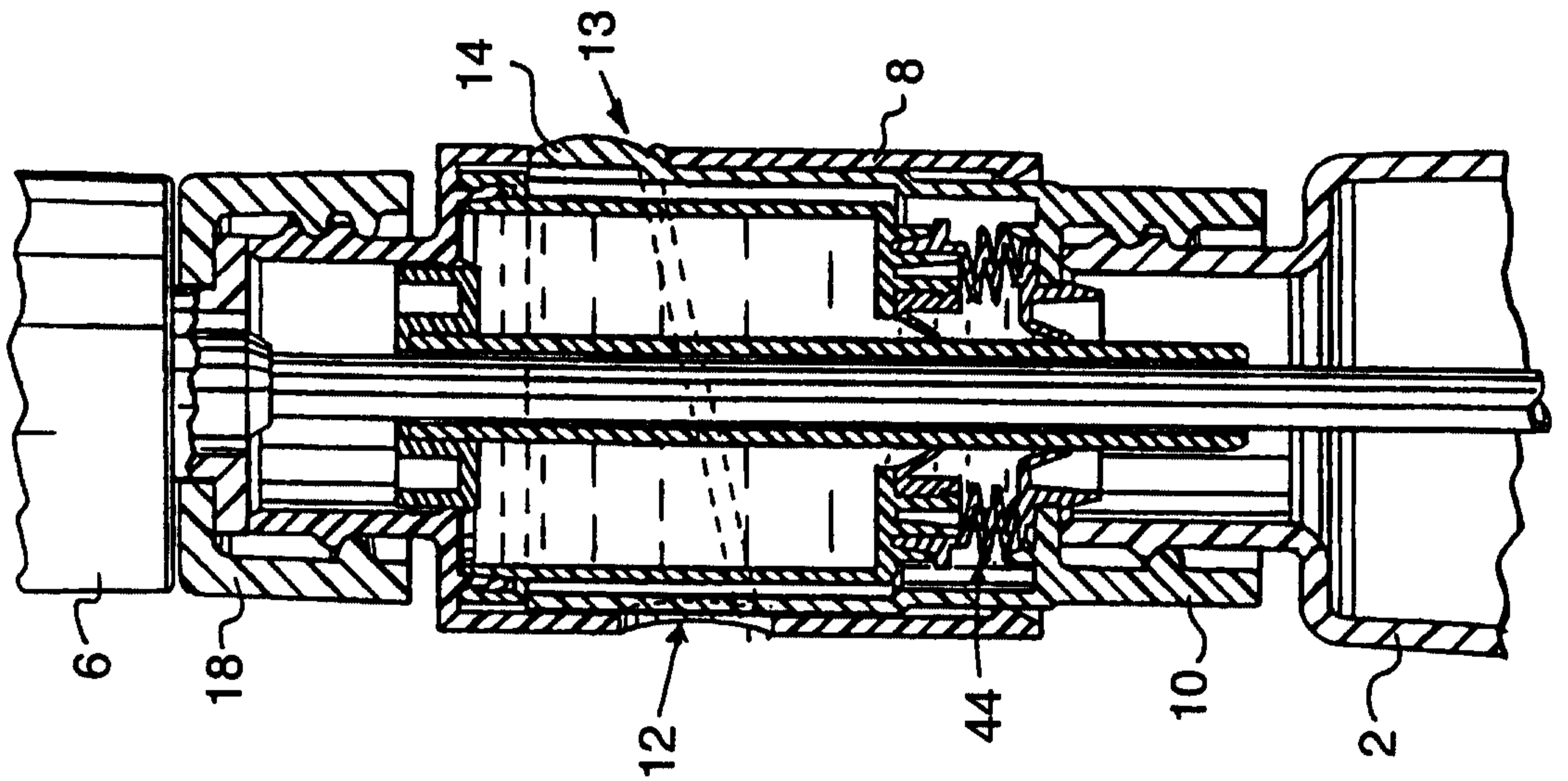

Fig.4.

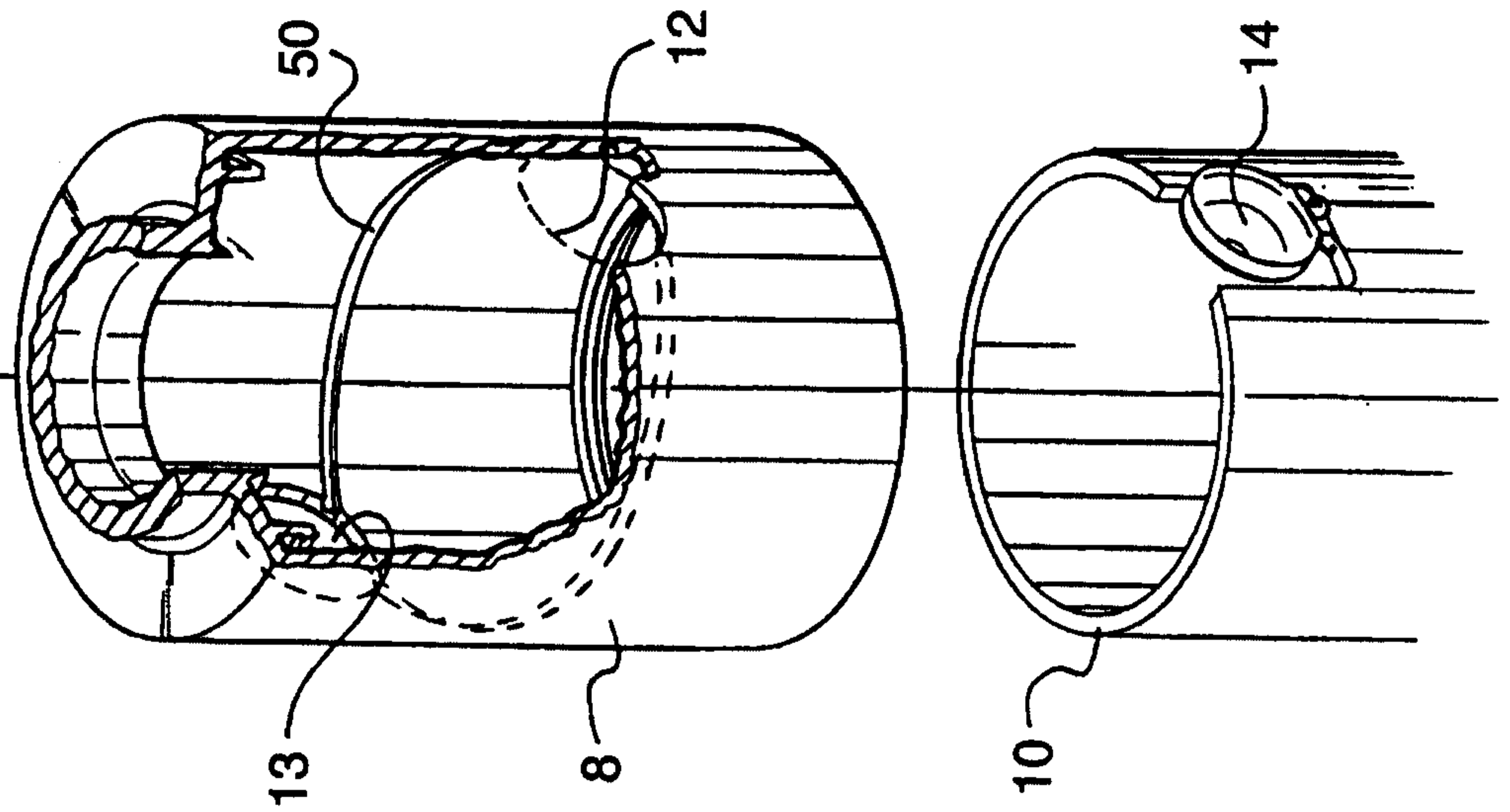

Fig.7.

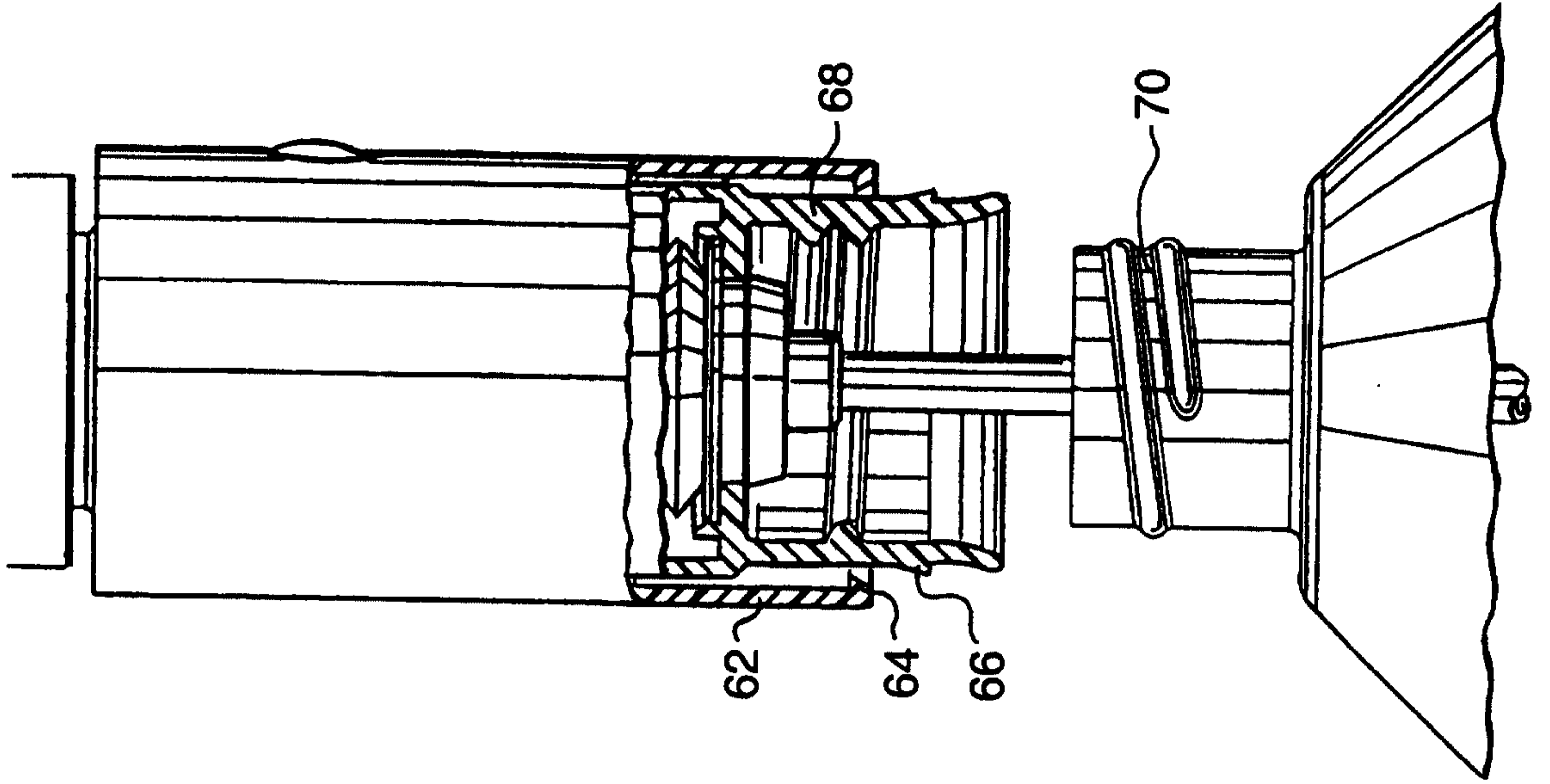

Fig.6.

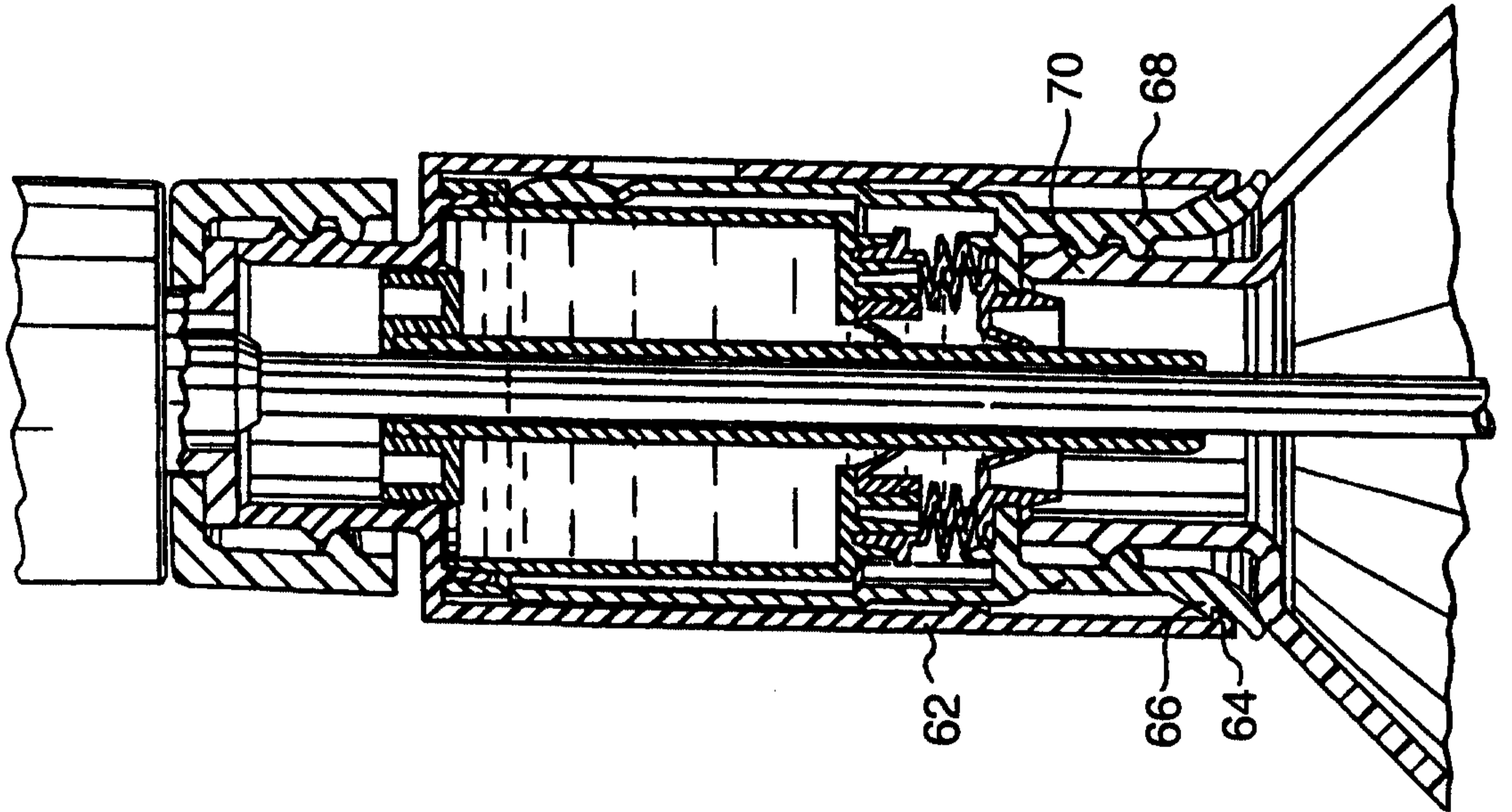

Fig.5.

