



(51) International Patent Classification:

E04H 4/16 (2006.01) G01S 7/481 (2006.01)
G01S 5/16 (2006.01) G01S 17/89 (2006.01)

(21) International Application Number:

PCT/US2019/046583

(22) International Filing Date:

14 August 2019 (14.08.2019)

(25) Filing Language:

English

(26) Publication Language:

English

(30) Priority Data:

62/719,867 20 August 2018 (20.08.2018) US

(71) Applicant: **ZODIAC POOL SYSTEMS LLC** [US/US];
2882 Whiptail Loop East #100, Carlsbad, California 92010 (US).

(72) Inventors: **NEWMAN, Phillip**; 7A Riley Crescent, 3290 Howick (ZA). **VAN DER MEIJDEN, Abian**; 58 Rosies Place Street, 1685 Glen Austin, Midrand (ZA). **VAN DER MEIJDEN, Hendrikus Johannes**; 58 Rosies Place Street, 1685 Glen Austin, Midrand (ZA).

(74) Agent: **RUSSELL, Dean W.**; Kilpatrick Townsend & Stockton LLP, 1100 Peachtree Street NE, Suite 2800, Mailstop: IP Docketing - 22, Atlanta, Georgia 30309 (US).

(81) Designated States (unless otherwise indicated, for every kind of national protection available):

AE, AG, AL, AM, AO, AT, AU, AZ, BA, BB, BG, BH, BN, BR, BW, BY, BZ, CA, CH, CL, CN, CO, CR, CU, CZ, DE, DJ, DK, DM, DO, DZ, EC, EE, EG, ES, FI, GB, GD, GE, GH, GM, GT, HN, HR, HU, ID, IL, IN, IR, IS, JO, JP, KE, KG, KH, KN, KP, KR, KW, KZ, LA, LC, LK, LR, LS, LU, LY, MA, MD, ME, MG, MK, MN, MW, MX, MY, MZ, NA, NG, NI, NO, NZ, OM, PA, PE, PG, PH, PL, PT, QA, RO, RS, RU, RW, SA, SC, SD, SE, SG, SK, SL, SM, ST, SV, SY, TH, TJ, TM, TN, TR, TT, TZ, UA, UG, US, UZ, VC, VN, ZA, ZM, ZW.

(84) Designated States (unless otherwise indicated, for every kind of regional protection available):

ARIPO (BW, GH, GM, KE, LR, LS, MW, MZ, NA, RW, SD, SL, ST, SZ, TZ, UG, ZM, ZW), Eurasian (AM, AZ, BY, KG, KZ, RU, TJ, TM), European (AL, AT, BE, BG, CH, CY, CZ, DE, DK, EE, ES, FI, FR, GB, GR, HR, HU, IE, IS, IT, LT, LU, LV, MC, MK, MT, NL, NO, PL, PT, RO, RS, SE, SI, SK, SM, TR), OAPI (BF, BJ, CF, CG, CI, CM, GA, GN, GQ, GW, KM, ML, MR, NE, SN, TD, TG).

Published:

— with international search report (Art. 21(3))

(54) Title: MAPPING AND TRACKING METHODS AND SYSTEMS PRINCIPALLY FOR USE IN CONNECTION WITH SWIMMING POOLS AND SPAS

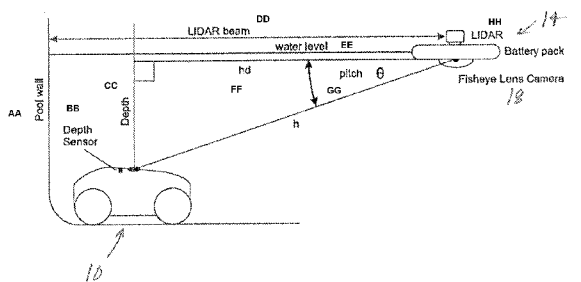

FIG. 5

(57) Abstract: Cleaning of a swimming pool may be facilitated by systems and methods for mapping a pool environment. Such mapping may occur in three dimensions when appropriate. At least some of the systems may include an apparatus for light detection and ranging (LIDAR) (14) tethered to an automatic swimming pool cleaner (18).



**MAPPING AND TRACKING METHODS AND SYSTEMS
PRINCIPALLY FOR USE IN CONNECTION WITH
SWIMMING POOLS AND SPAS**

CROSS-REFERENCE TO RELATED APPLICATION

This application claims the benefit of and priority to U.S. Provisional Patent Application Serial No. 62/719,867, filed August 20, 2018, and having the same title as appears above (the “Provisional Application”), the entire contents of which Provisional Application are hereby incorporated herein by this reference.

FIELD OF THE INVENTION

This invention relates to mapping and tracking systems and more particularly, although not necessarily exclusively, to systems for mapping characteristics of water-containing vessels such as swimming pools or spas and tracking positions of moveable equipment, such as an automatic pool cleaner (“APC”), within the vessels.

BACKGROUND OF THE INVENTION

European Patent Application No. 1122382 of Clementi (the “Clementi Application”), whose entire contents are incorporated herein by this reference, illustrates an APC capable of moving over to-be-cleaned surfaces of a swimming pool. Connected to the APC via a cable is a shuttle incorporating a battery, a microcontroller, and a signal transmitter and receiver. The shuttle, described in the Clementi Application as “a sort of floating ‘island,’” floats on the surface of water within a swimming pool and is towed by the APC as the latter moves within the pool.

Absent from the shuttle of the Clementi Application is any capability of tracking location of the mobile APC within the pool. Similarly absent from the shuttle is any ability to track its own position within a pool or to determine any characteristics of the pool itself. Because all of this information is valuable in the context of efficiently and

effectively cleaning vessels such as swimming pools and spas, it would be advantageous to develop methods and systems for obtaining some or all of it.

SUMMARY OF THE INVENTION

The present invention provides such methods and systems. In a general sense, the invention facilitates more efficient and cost-effective cleaning of swimming pools by mapping a pool environment in three dimensions, performing path planning for an APC, and assisting in navigating the APC along the planned paths. The APC may have an on-board power source for effecting autonomous movement within a pool as well as a pump to draw debris-laden pool water through a filter for cleaning, although components such as these alternatively may be located remote from the APC.

BRIEF DESCRIPTION OF THE DRAWINGS

FIG. 1 illustrates an exemplary floating object configured to facilitate mapping and tracking in connection with the present invention.

FIG. 2 schematically illustrates exemplary information which may be gleaned by a ranging sensor floating within a swimming pool.

FIG. 3 illustrates an exemplary camera that may be used in connection with the floating object of FIG. 1.

FIG. 4 schematically illustrates exemplary positions of an APC relative to the camera of FIG. 3.

FIG. 5 diagrammatically illustrates development of a three-dimension estimate of a position of an APC relative to the floating object of FIG. 1.

DETAILED DESCRIPTION

Tethered to the APC 10 (*see, e.g.*, FIGS. 4-5) may be a floating object 14 configured to facilitate mapping and tracking. Advantageously, the tether may be or

include a cable configured to convey electronic data between the APC 10 and the floating object 14. The cable additionally may, in some cases, convey electrical power to the APC 10 as well, as advantageously the floating object 14 includes an on-board battery or other source of power both for it and for the APC 10. One presently-preferred tether is a cable approximately 2.4m in length, although persons skilled in the art will recognize that shorter or longer cables may be used instead. As the APC 10 moves within the pool, it tows the floating object along the water surface.

In some versions of the invention, the floating object 14 may include apparatus for light detection and ranging (“LIDAR”). As known to persons skilled in the relevant art, LIDAR constitutes methods of measuring distance to a target by illuminating the target with pulsed laser light and sensing the reflected pulses with a sensor. Presently preferred is that the LIDAR apparatus have a rotating time of flight (“ToF”) ranging sensor projecting above the waterline of the pool (so as to send laser light through air, rather than water) that generally continuously collects data as it scans the walls forming the perimeter of a pool at and above the waterline. An exemplary such sensor rotates at approximately 5 Hz and collects approximately 500-1000 samples of ranging and angular data per cycle. The LIDAR apparatus thus may develop an accurate mapping of the pool perimeter as well as of its position within the perimeter of the pool.

FIG. 2 schematically illustrates exemplary distance and angle information which may be gleaned by rotating through 360° a ToF ranging sensor floating within a pool. Because rotation of the sensor through one revolution is materially faster than an APC 10 typically travels within a pool, linear movement of the tethered APC 10 either may be ignored or accounted for when obtaining distance and angle information for a particular cycle. In some versions of the invention, conventional techniques of

simultaneous localization and mapping (“SLAM”) may be employed in processing data obtained by the ToF ranging sensor of the LIDAR apparatus.

The floating object 14 additionally may include a camera 18 (*see* FIG. 3) configured to record images of the APC 10 to which the object 14 is tethered.

Advantageously, the camera 18 may have a “fish-eye” type of lens whose fields of view (“FOV”) both horizontally and vertically are 180° (or approximately so). Similarly advantageously, the camera 18 is integrated into or attached to the floating object 14 facing downward into the water of the pool. The camera 18 is configured to record the underwater scene with the APC 10 constantly in view, which is possible due to the relatively short length of the cable. Conventional techniques of visual simultaneous localization and mapping (“VSLAM”) may be utilized to process its image data.

In particular, the APC 10 may include any suitable marker (*e.g.*, a red dot) on its body that the camera 18 may track continuously in its video frame. Preferably the marker is located on a top, central portion of the body, although it may be located elsewhere instead. The position of the marker as tracked through the camera 18 (by associated hardware or software, or both) may provide information as to the heading and pitch of the APC 10 relative to the LIDAR apparatus, samples of which are schematically depicted in FIG. 4. Collectively, the LIDAR apparatus and camera 18 supply information sufficient to determine various dimensions and contours of the pool in which the object 14 is floating as well as certain information respecting locations of the APC 10 (in “x” and “y” coordinates) and the floating object 14 itself.

In some embodiments of the invention, the APC 10 includes a depth sensor configured to supply additional information (a “z” coordinate) as to its position within a pool. By utilizing depth information together with information as to marker heading and

pitch angle, a three-dimensional estimate of the APC's position relative to the LIDAR apparatus may be obtained (*see* FIG. 5). And because the position of the LIDAR apparatus within the pool relative to the pool walls is known via the ToF ranging sensor, an accurate determination of the location of the APC 10 within the pool may be made.

Yet additionally, the APC 10 may include an inertial measurement unit or other device configured to provide information as to how the APC 10 is tilted. Considered altogether, therefore, information gathered by the floating object 14 may supply accurate estimates of position and orientation of the APC 10 excluding its azimuth direction. Although the absolute direction the APC 10 is facing is not necessarily known if the APC 10 is stationary, such direction becomes apparent as soon as the APC 10 moves forward or backward from a particular position. Alternatively, azimuth direction could be set by use of a second marker located on the APC 10 at a distance from the other marker. Accordingly, at this point all relevant absolute position and orientation estimates may be obtained for the APC 10 relative to the pool, allowing precise pool mapping, path planning, and navigation. Any or all of this information, further, may be recorded and displayed in any suitable manner for evaluation by a pool user, pool equipment technician or manufacturer, or otherwise.

Moreover, the floating object 14 may perform some or all of the functions attributed to the shuttle of the Clementi Application. It thus may, if desired, include any or all of at least one battery, controller (including processing capabilities), and signal transmitter and receiver. The floating object 14 further could include components such as solar panels for charging the battery, for example.

Exemplary concepts or combinations of features of the invention may include:

- A. A method of mapping a pool using a device floating on water within the swimming pool.
- B. A method of mapping a swimming pool using a LIDAR apparatus.
- C. A method of cleaning a swimming pool comprising (i) obtaining information from a sensor of a LIDAR apparatus and a camera positioned within the pool, (ii) processing the obtained information, and (iii) conveying navigation information via a cable to an APC travelling along a surface of the pool.
- D. A cleaning system comprising: (i) a floating object comprising a LIDAR apparatus, (ii) an APC, and (iii) a cable connecting the LIDAR apparatus and the APC both mechanically and electronically.

These examples are not intended to be mutually exclusive, exhaustive, or restrictive in any way, and the invention is not limited to these exemplary embodiments but rather encompasses all possible modifications and variations within the scope of any claims ultimately drafted and issued in connection with the invention (and their equivalents). For avoidance of doubt, any combination of features not physically impossible or expressly identified as non-combinable herein may be within the scope of the invention.

Included in connection with the figures of the Provisional Application was at least the following text:

FIG. 1: Floating battery pack

--LIDAR

--Battery

--Camera

FIG. 2: Basic SLAM (simultaneous localization and mapping) is continuously performed to establish the position and rotation of the floating

LIDAR at any time. The rotational reference of the LIDAR is known relative to the first data sample at each 360° scan. Thus if the LIDAR is rotated in the pool, the rotation of the LIDAR base is also known relative to its starting rotation as long as SLAM calculations are ongoing.

FIG. 3: Camera (180° FOV)

Attached to the floating LIDAR is a camera facing straight down which has a fish-eye lens with a horizontal and vertical field of view of 180° .

The camera records the underwater scene with the pool cleaner constantly in view. This is almost guaranteed because of its relatively short cable. There is a tracking marker on top and more or less on the center of the cleaner that is tracked continuously in the video frame. The position of the marker on the screen gives us the relative heading and pitch of the cleaner to the floating LIDAR.

FIG. 4: Image showing various cleaner positions relative to the camera providing heading and pitch relative to the screen center.

FIG. 5: The pool cleaner has a depth sensor. The depth information is applied to the marker heading and pitch angles which then gives us a 3 dimensional estimate relative to the floating LIDAR which in turn has an absolute reference to the pool outline (real world). This gives us an accurate estimate of where the pool cleaner is in the pool at any given point in time. Coupled to that the cleaner also has an IMU (inertial measurement unit) that provides tilt information. The above mentioned solution thus provides us with an accurate cleaner position and orientation estimation excluding its azimuth direction. The absolute direction that the pool cleaner is facing is not known if it is stationary but soon becomes apparent when it moves forward or backward from a previous

position. Thus the solution finally provides an absolute position and orientation estimate relative to the pool. The above is sufficient for pool mapping, path planning and navigation.

Given a certain pitch angle Θ and a depth one can determine h as well as hd horizontal distance from the LIDAR unit. Heading is also provided from the tracked marker in each camera frame.

Further, although applicant has described devices and techniques for use principally with swimming pools, persons skilled in the relevant field will recognize that the present invention may be employed in connection with other objects and in other manners. Variants of the invention, moreover, allow for use of one or more cameras on the top of the floating object in addition to (or instead of) the LIDAR apparatus to track fixed-location objects outside the pool as well as aid in mapping the pool perimeter. These fixed-location objects could then serve as reference points for assessing the location of the floating object.

Other variants contemplate use of a more complex range of markers or fiducials placed on the APC and which are visible to the camera to allow determination, through image processing, of such things as direction and bank, pitch and roll angles. Yet alternatively, a camera may be placed on the APC to capture images of the floating island, to whose bottom surface one or more markers or fiducials have been attached, again facilitating determination of the relative positions of the APC and floating object. Finally, references to “pools” and “swimming pools” herein may also refer to spas or other water-containing vessels used for recreation or therapy and for which mapping or tracking is needed or desired.

What is claimed is:

1. A cleaning system comprising: (a) a floating object comprising a LIDAR apparatus, (b) an automatic pool cleaner, and (c) a tether connecting the LIDAR apparatus and the automatic pool cleaner.
2. A cleaning system according to claim 1 in which the tether comprises a cable connecting the LIDAR apparatus and the automatic pool cleaner both mechanically and electronically.
3. A cleaning system according to claim 2 in which the floating object further comprises a camera.
4. A cleaning system according to claim 3 in which the LIDAR apparatus comprises a rotating ranging sensor projecting above a waterline of a swimming pool when the floating object is floating in the swimming pool.
5. A cleaning system according to claim 4 in which the camera faces downward into the swimming pool when the floating object is floating in the swimming pool.
6. A cleaning system according to claim 5 in which the automatic pool cleaner comprises a marker which the camera is configured to track.
7. A cleaning system according to claim 6 in which the automatic pool cleaner further comprises a depth sensor.
8. A cleaning system according to claim 7 in which the automatic pool cleaner further comprises a tilt sensor.
9. A cleaning system according to claim 8 in which the floating object further comprises a battery and a controller.
10. A method of cleaning a swimming pool comprising (a) obtaining information from a sensor of a LIDAR apparatus and a camera positioned within the

swimming pool, (b) processing the obtained information, and (c) conveying navigation information via a cable to an automatic pool cleaner travelling along a surface of the swimming pool.

11. A method of mapping a swimming pool using a device floating on water within the swimming pool.

12. A method of mapping a swimming pool using a LIDAR apparatus.

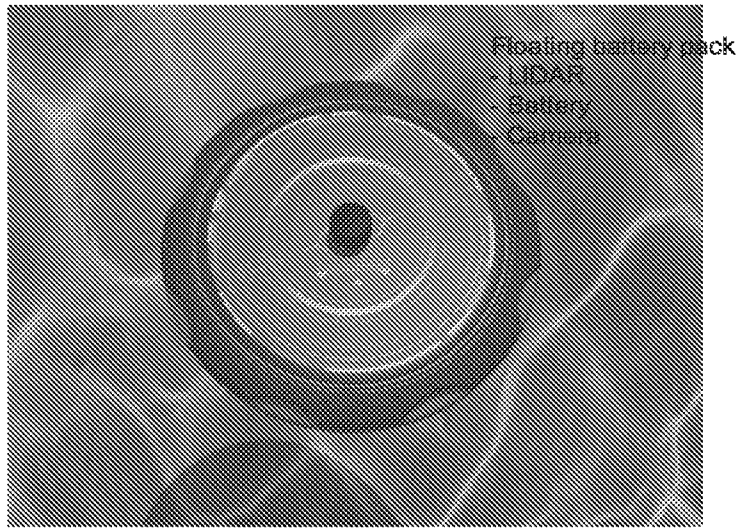

14 ↗

FIG. 1

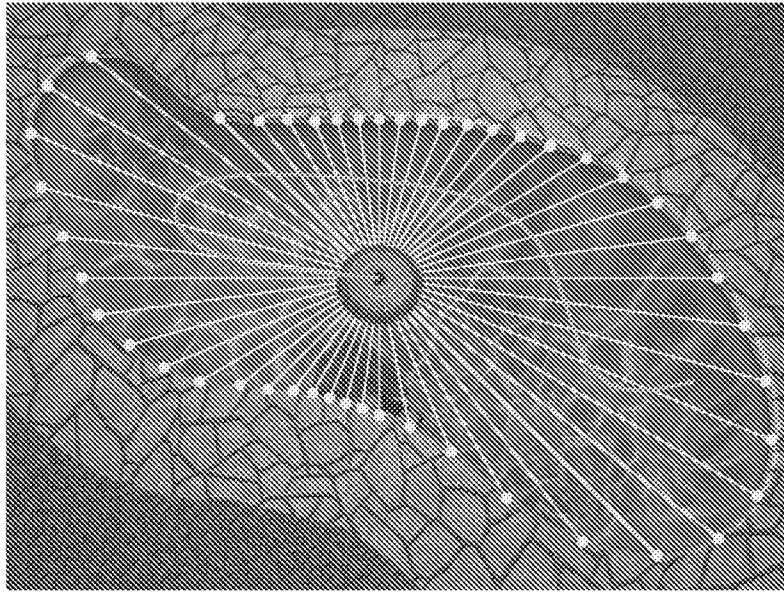

Path traced by floating LIDAR during SLAM in green

14

FIG. 2

3/5

18 →

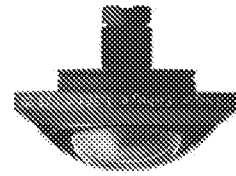
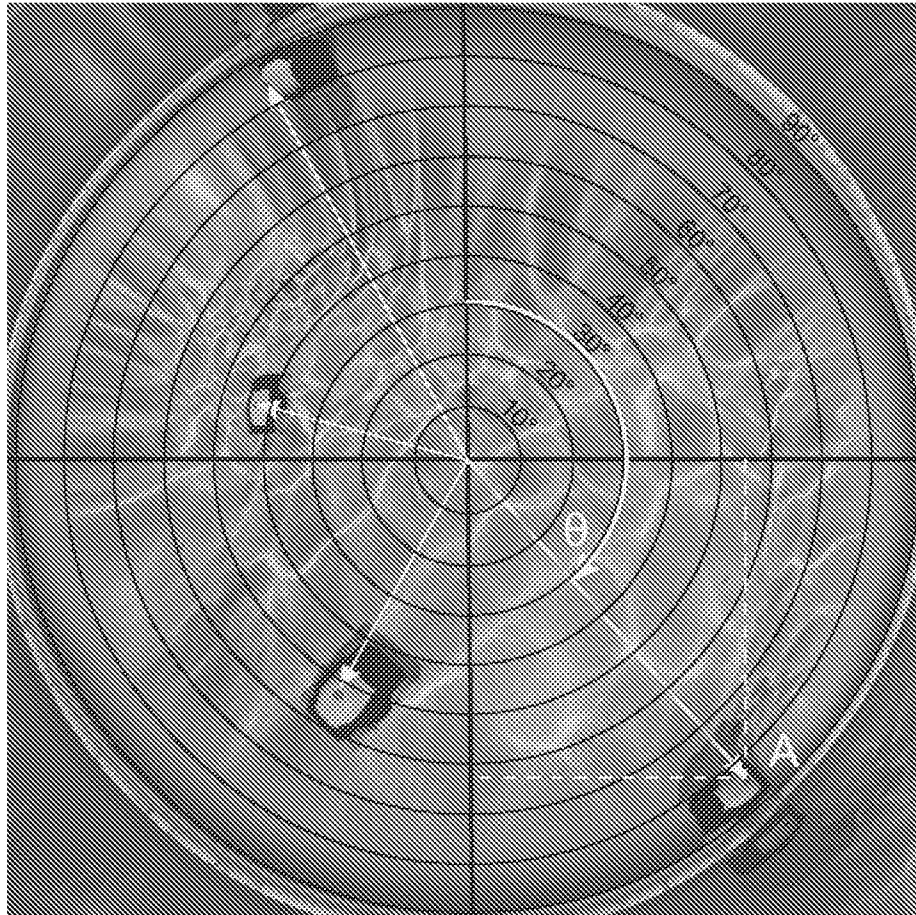

FIG. 3



10 →

FIG. 4

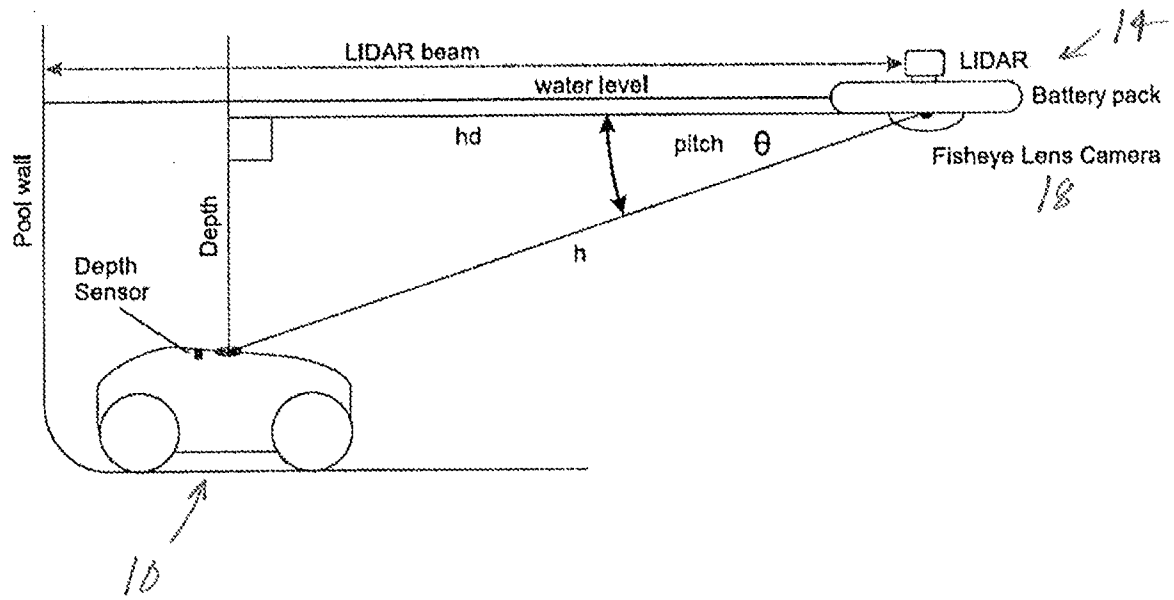

FIG. 5

INTERNATIONAL SEARCH REPORT

International application No
PCT/US2019/046583

A. CLASSIFICATION OF SUBJECT MATTER
INV. E04H4/16 G01S5/16 G01S7/481 G01S17/89
ADD.
According to International Patent Classification (IPC) or to both national classification and IPC

B. FIELDS SEARCHED
Minimum documentation searched (classification system followed by classification symbols)
E04H G01S
Documentation searched other than minimum documentation to the extent that such documents are included in the fields searched

Electronic data base consulted during the international search (name of data base and, where practicable, search terms used)
EPO-Internal

C. DOCUMENTS CONSIDERED TO BE RELEVANT		
Category*	Citation of document, with indication, where appropriate, of the relevant passages	Relevant to claim No.
X Y A	DE 10 2007 053310 A1 (BOSCH GMBH ROBERT [DE]) 10 June 2009 (2009-06-10) paragraphs [0005], [0007], [0009], [0014], [0015], [0018], [0019], [0022], [0027] - [0029]; figures 1,2 -----	1-4,10, 12 1-4 5-9,11
X Y A	EP 2 960 741 A2 (BOSCH GMBH ROBERT [DE]) 30 December 2015 (2015-12-30) paragraphs [0004], [0011], [0012]; figures 1,2 -----	10,12 1-4 5-9
X Y	WO 2018/077870 A1 (TRINAMIX GMBH [DE]) 3 May 2018 (2018-05-03) page 53, lines 13-21; claim 9 -----	10,12 1-4
	-/--	

Further documents are listed in the continuation of Box C.

See patent family annex.

* Special categories of cited documents :

<p>"A" document defining the general state of the art which is not considered to be of particular relevance</p> <p>"E" earlier application or patent but published on or after the international filing date</p> <p>"L" document which may throw doubts on priority claim(s) or which is cited to establish the publication date of another citation or other special reason (as specified)</p> <p>"O" document referring to an oral disclosure, use, exhibition or other means</p> <p>"P" document published prior to the international filing date but later than the priority date claimed</p>	<p>"T" later document published after the international filing date or priority date and not in conflict with the application but cited to understand the principle or theory underlying the invention</p> <p>"X" document of particular relevance; the claimed invention cannot be considered novel or cannot be considered to involve an inventive step when the document is taken alone</p> <p>"Y" document of particular relevance; the claimed invention cannot be considered to involve an inventive step when the document is combined with one or more other such documents, such combination being obvious to a person skilled in the art</p> <p>"&" document member of the same patent family</p>
---	---

Date of the actual completion of the international search 19 November 2019	Date of mailing of the international search report 28/11/2019
---	--

Name and mailing address of the ISA/ European Patent Office, P.B. 5818 Patentlaan 2 NL - 2280 HV Rijswijk Tel. (+31-70) 340-2040, Fax: (+31-70) 340-3016	Authorized officer Decker, Robert
--	--

INTERNATIONAL SEARCH REPORT

International application No
PCT/US2019/046583

C(Continuation). DOCUMENTS CONSIDERED TO BE RELEVANT		
Category*	Citation of document, with indication, where appropriate, of the relevant passages	Relevant to claim No.
X	CN 108 387 234 A (GUANGZHOU COAYU ROBOT CO LTD) 10 August 2018 (2018-08-10)	10,12
Y	paragraphs [0001], [0059], [0081]	1-4
A		5-9

X	EP 3 282 072 A1 (AQUATRON ROBOTIC TECH LTD [IL]) 14 February 2018 (2018-02-14)	11
Y	paragraphs [0060] - [0062], [0100],	1-4
A	[0101]; figure 2	5-9

X	WO 2014/004929 A2 (PENTAIR WATER POOL & SPA INC [US] ET AL.)	10-12
	3 January 2014 (2014-01-03)	
A	the whole document	1-9

X	WO 2008/155178 A1 (BOSCH GMBH ROBERT [DE]; BENZLER ULRICH-LORENZ [DE] ET AL.)	11
	24 December 2008 (2008-12-24)	
A	page 20, line 20 - page 22, line 15; figures 2,3	1

INTERNATIONAL SEARCH REPORT

Information on patent family members

International application No

PCT/US2019/046583

Patent document cited in search report	Publication date	Patent family member(s)	Publication date
DE 102007053310 A1	10-06-2009	NONE	
EP 2960741 A2	30-12-2015	DE 102014212418 A1 EP 2960741 A2	31-12-2015 30-12-2015
WO 2018077870 A1	03-05-2018	CN 109923372 A EP 3532796 A1 JP 2019532517 A KR 20190072545 A US 2019277703 A1 WO 2018077870 A1	21-06-2019 04-09-2019 07-11-2019 25-06-2019 12-09-2019 03-05-2018
CN 108387234 A	10-08-2018	CN 108387234 A WO 2019154119 A1	10-08-2018 15-08-2019
EP 3282072 A1	14-02-2018	EP 3282071 A1 EP 3282072 A1 ES 2715493 T3 US 2018044936 A1 US 2019093379 A1 US 2019093380 A1	14-02-2018 14-02-2018 04-06-2019 15-02-2018 28-03-2019 28-03-2019
WO 2014004929 A2	03-01-2014	AU 2013284446 A1 AU 2017245357 A1 BR 112014032713 A2 CA 2877919 A1 CN 105308414 A CN 108661362 A EP 2867611 A2 US 2014009748 A1 US 2015267433 A1 US 2018320398 A1 WO 2014004929 A2	12-02-2015 02-11-2017 27-06-2017 03-01-2014 03-02-2016 16-10-2018 06-05-2015 09-01-2014 24-09-2015 08-11-2018 03-01-2014
WO 2008155178 A1	24-12-2008	DE 102007053311 A1 EP 2160663 A1 US 2010299016 A1 WO 2008155178 A1	24-12-2008 10-03-2010 25-11-2010 24-12-2008