

(19) World Intellectual Property Organization
International Bureau



(43) International Publication Date
18 January 2007 (18.01.2007)

PCT

(10) International Publication Number
WO 2007/008003 A2

- (51) International Patent Classification:
G10L 19/00 (2006.01)
- (21) International Application Number:
PCT/KR2006/002681
- (22) International Filing Date: 10 July 2006 (10.07.2006)
- (25) Filing Language: English
- (26) Publication Language: English
- (30) Priority Data:

60/697,551	11 July 2005 (11.07.2005)	US
PCT/KR2005/002290	16 July 2005 (16.07.2005)	KR
PCT/KR2005/002291	16 July 2005 (16.07.2005)	KR
PCT/KR2005/002292	16 July 2005 (16.07.2005)	KR
PCT/KR2005/002306	18 July 2005 (18.07.2005)	KR
PCT/KR2005/002307	18 July 2005 (18.07.2005)	KR
PCT/KR2005/002308	18 July 2005 (18.07.2005)	KR
60/700,570	19 July 2005 (19.07.2005)	US

(81) Designated States (unless otherwise indicated, for every kind of national protection available): AE, AG, AL, AM, AT, AU, AZ, BA, BB, BG, BR, BW, BY, BZ, CA, CH, CN, CO, CR, CU, CZ, DE, DK, DM, DZ, EC, EE, EG, ES, FI, GB, GD, GE, GH, GM, HN, HR, HU, ID, IL, IN, IS, JP, KE, KG, KM, KN, KP, KR, KZ, LA, LC, LK, LR, LS, LT, LU, LV, LY, MA, MD, MG, MK, MN, MW, MX, MZ, NA, NG, NI, NO, NZ, OM, PG, PH, PL, PT, RO, RS, RU, SC, SD, SE, SG, SK, SL, SM, SY, TJ, TM, TN, TR, TT, TZ, UA, UG, US, UZ, VC, VN, ZA, ZM, ZW.

(84) Designated States (unless otherwise indicated, for every kind of regional protection available): ARIPO (BW, GH, GM, KE, LS, MW, MZ, NA, SD, SL, SZ, TZ, UG, ZM, ZW), Eurasian (AM, AZ, BY, KG, KZ, MD, RU, TJ, TM), European (AT, BE, BG, CH, CY, CZ, DE, DK, EE, ES, FI, FR, GB, GR, HU, IE, IS, IT, LT, LU, LV, MC, NL, PL, PT, RO, SE, SI, SK, TR), OAPI (BF, BJ, CF, CG, CI, CM, GA, GN, GQ, GW, ML, MR, NE, SN, TD, TG).

- (71) Applicant (for all designated States except US): LG ELECTRONICS INC. [KR/KR]; 20, Yoido-dong, Youngdungpo-gu, Seoul 150-721 (KR).
- (72) Inventor; and
- (75) Inventor/Applicant (for US only): LIEBCHEN, Tilman [DE/DE]; Lefevrestrasse 17, 12161 Berlin (DE).
- (74) Agents: BAHNG, Hae Cheol et al.; 15th Floor, Yo Sam Building, 648-23 Yeoksam-dong, Kangnam-gu, Seoul 135-080 (KR).

Published:
— without international search report and to be republished upon receipt of that report

For two-letter codes and other abbreviations, refer to the "Guidance Notes on Codes and Abbreviations" appearing at the beginning of each regular issue of the PCT Gazette.

(54) Title: APPARATUS AND METHOD OF ENCODING AND DECODING AUDIO SIGNAL

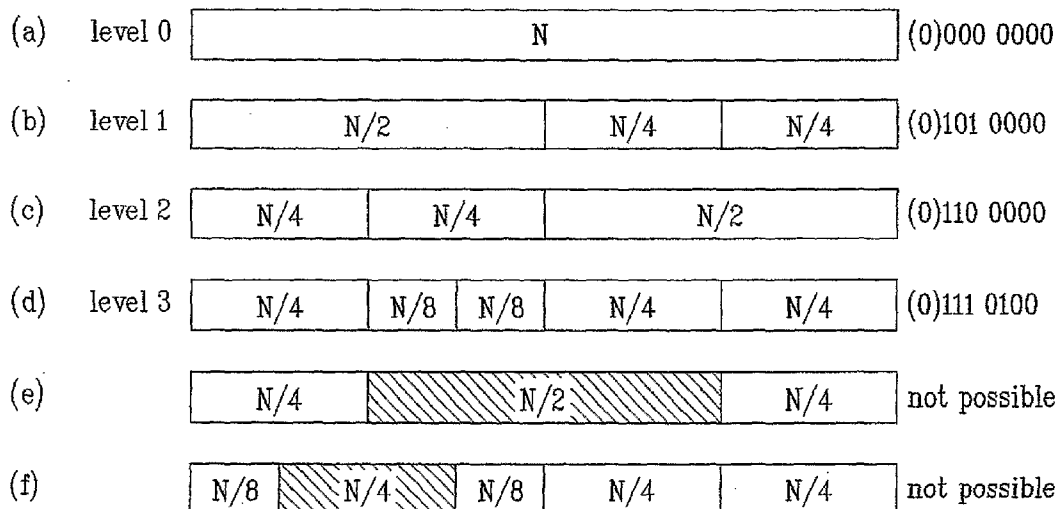

(57) Abstract: In one embodiment, a channel in a frame of the audio signal is subdivided into a plurality of blocks according to a subdivision hierarchy. The subdivision hierarchy has more than one level, and each level being associated with a different block length. At least two of the blocks have different lengths. First subdivision information may be generated indicating a number of levels in the subdivision hierarchy, and second subdivision information may be generated indicating the subdivision of the channel into the blocks. A length of the second subdivision information depends on the first subdivision information.

WO 2007/008003 A2

[DESCRIPTION]

APPARATUS AND METHOD OF ENCODING AND DECODING AUDIO SIGNAL

BACKGROUND OF THE INVENTION

5 The present invention relates to a method for processing audio signal, and more particularly to a method and apparatus of encoding and decoding audio signal.

The storage and replaying of audio signals has been accomplished in different ways in the past. For example,
10 music and speech have been recorded and preserved by phonographic technology (e.g., record players), magnetic technology (e.g., cassette tapes), and digital technology (e.g., compact discs). As audio storage technology progresses, many challenges need to be overcome to optimize the quality
15 and storability of audio signals.

For the archiving and broadband transmission of music signals, lossless reconstruction is becoming a more important feature than high efficiency in compression by means of perceptual coding as defined in MPEG standards such as MP3 or AAC.
20 Although DVD audio and Super CD Audio include proprietary lossless compression schemes, there is a demand for an open and general compression scheme among content-holders and broadcasters. In response to this demand, a new lossless coding scheme has been considered as an extension to the MPEG-
25 4 Audio standard. Lossless audio coding permits the

compression of digital audio data without any loss in quality due to a perfect reconstruction of the original signal.

SUMMARY OF THE INVENTION

5 The present invention relates to method of processing an audio signal.

In one embodiment, a channel in a frame of the audio signal is subdivided into a plurality of blocks according to a subdivision hierarchy. The subdivision hierarchy has more than
10 one level, and each level being associated with a different block length. At least two of the blocks have different lengths. First subdivision information may be generated indicating a number of levels in the subdivision hierarchy, and second subdivision information may be generated indicating
15 the subdivision of the channel into the blocks. A length of the second subdivision information depends on the first subdivision information.

In one embodiment, the first subdivision information may be included in a header of the audio signal. For example, the
20 first subdivision information may include 2 bits.

In one embodiment, the first subdivision information indicates whether the subdivision hierarchy includes one of up to three levels, four levels, and five levels. For example, if the first subdivision information is 01, the first subdivision
25 information indicates the subdivision hierarchy includes up to

three levels; if the first subdivision information is 10, the first subdivision information indicates the subdivision hierarchy includes four levels; and if the first subdivision information is 11, the first subdivision information indicates the subdivision hierarchy includes five levels.

In one embodiment, a length of the second subdivision information is 8 bits if the first subdivision information indicates the subdivision hierarchy includes up to three levels, is 16 bits if the first subdivision information indicates the subdivision hierarchy includes four levels, and is 32 bits if the first subdivision information indicates the subdivision hierarchy includes five levels.

In an embodiment, the second subdivision information is included in a header of the audio signal.

In one embodiment, the second subdivision information may be generated such that the second subdivision information includes a number of information bits, and the information bits indicate the subdivision of the channel into the blocks. For example, each information bit is associated with a level in the subdivision hierarchy and is associated with a block at the associated level, and each information bit indicates whether the associated block was subdivided.

In one embodiment, the method further includes predicting current data samples in the channel based on previous data samples. The number of the previous data samples used in the

predicting is referred to as the prediction order. A residual of the current data samples is obtained based on the predicted data samples.

The present invention further relates to methods and apparatuses for encoding an audio signal, and to methods and apparatuses for decoding an audio signal.

BRIEF DESCRIPTION OF THE DRAWINGS

The accompanying drawings, which are included to provide a further understanding of the invention and are incorporated in and constitute a part of this application, illustrate embodiment(s) of the invention and together with the description serve to explain the principle of the invention. In the drawings:

FIG. 1 is an example illustration of an encoder according to an embodiment of the present invention.

FIG. 2 is an example illustration of a decoder according to an embodiment of the present invention.

FIG. 3 is an example illustration of a bitstream structure of a compressed M -channel file according to an embodiment of the present invention.

FIG. 4 is an example illustration of a conceptual view of a hierarchical block switching method according to an embodiment of the present invention.

FIG. 5 is an example illustration of a block switching

examples and corresponding block switching information codes.

FIG. 6 is an example illustration of block switching methods for a plurality of channel according to embodiments of the present invention.

5

DETAILED DESCRIPTION OF EXAMPLE EMBODIMENTS

Reference will now be made in detail to the preferred embodiments of the present invention, examples of which are
10 illustrated in the accompanying drawings. Wherever possible, the same reference numbers will be used throughout the drawings to refer to the same or like parts.

Prior to describing the present invention, it should be noted that most terms disclosed in the present invention correspond
15 to general terms well known in the art, but some terms have been selected by the applicant as necessary and will hereinafter be disclosed in the following description of the present invention. Therefore, it is preferable that the terms defined by the applicant be understood on the basis of their
20 meanings in the present invention.

In a lossless audio coding method, since the encoding process has to be perfectly reversible without loss of information, several parts of both encoder and decoder have to be implemented in a deterministic way.

25

Codec Structure

FIG. 1 is an example illustration of an encoder 1 according to the present invention.

A partitioning part 100 partitions the input audio data into
5 frames. Within one frame, each channel may be further subdivided into blocks of audio samples for further processing. A buffer 110 stores block and/or frame samples partitioned by the partitioning part 100.

A coefficient estimating part 120 estimates an optimum set of
10 coefficient values for each block. The number of coefficients, i.e., the order of the predictor, can be adaptively chosen as well. The coefficient estimating part 120 calculates a set of parcor values for the block of digital audio data. The parcor value indicates parcor representation of the predictor
15 coefficient. A quantizing part 130 quantizes the set of parcor values.

A first entropy coding part 140 calculates parcor residual values by subtracting an offset value from the parcor value, and encodes the parcor residual values using entropy codes
20 defined by entropy parameters, wherein the offset value and the entropy parameters are chosen from an optimal table. The optimal table is selected from a plurality of tables based on a sampling rate of the block of digital audio data. The plurality of tables are predefined for a plurality of sampling
25 rate ranges, respectively, for optimal compression of the

digital audio data for transmission.

A coefficient converting part 150 converts the quantized parcor values into linear predictive coding (LPC) coefficients.

A predictor 160 estimates current prediction values from the
5 previous original samples stored in the buffer 110 using the
linear predictive coding coefficients. A subtracter 170
calculates a prediction residual of the block of digital audio
data using an original value of digital audio data stored in
the buffer 110 and a prediction value estimated in the
10 predictor 160.

A second entropy coding part 180 codes the prediction residual
using different entropy codes and generates code indices. The
indices of the chosen codes will be transmitted as auxiliary
information. The second entropy coding part 180 may code the
15 prediction residual using one of two alternative coding
techniques having different complexities. One coding
technique is the well-known Golomb-Rice coding (herein after
simply "Rice code") method and the other is the well-known
Block Gilbert-Moore Codes (herein after simply "BGMC") method.
20 Rice codes have low complexity yet are efficient. The BGMC
arithmetic coding scheme offers even better compression at the
expense of a slightly increased complexity compared to Rice
codes.

Finally, a multiplexing part 190 multiplexes coded prediction
25 residual, code indices, coded parcor residual values, and

other additional information to form a compressed bitstream. The encoder 1 also provides a cyclic redundancy check (CRC) checksum, which is supplied mainly for the decoder to verify the decoded data. On the encoder side, the CRC can be used to
5 ensure that the compressed data are losslessly decodable.

Additional encoding options include flexible block switching scheme, random access and joint channel coding. The encoder 1 may use these options to offer several compression levels with different complexities. The joint channel coding is used to
10 exploit dependencies between channels of stereo or multi-channel signals. This can be achieved by coding the difference between two channels in the segments where this difference can be coded more efficiently than one of the original channels. These encoding options will be described
15 in more detail below after a description of an example decoder according to the present invention.

FIG. 2 is an example illustration of a decoder 2 according to the present invention. More specially, FIG. 2 shows the lossless audio signal decoder which is significantly less
20 complex than the encoder, since no adaptation has to be carried out.

A demultiplexing part 200 receives an audio signal and demultiplexes a coded prediction residual of a block of digital audio data, code indices, coded parcor residual values
25 and other additional information. A first entropy decoding

part 210 decodes the parcor residual values using entropy codes defined by entropy parameters and calculates a set of parcor values by adding offset values to the decoded parcor residual values; wherein the offset value and the entropy parameters are chosen from a table selected by the decoder
5 from a plurality of tables based on a sampling rate of the block of digital audio data. A second entropy decoding part 220 decodes the demultiplexed coded prediction residual using the code indices. A coefficient converting part 230 converts
10 the entropy decoded parcor value into LPC coefficients. A predictor 240 estimates a prediction residual of the block of digital audio data using the LPC coefficients. An adder 250 adds the decoded prediction residual to the estimated prediction residual to obtain the original block of digital
15 audio data. An assembling part 260 assembles the decoded block data into frame data.

Therefore, the decoder 2 decodes the coded prediction residual and the parcor residual values, converts the parcor residual values into LPC coefficients, and applies the inverse
20 prediction filter to calculate the lossless reconstruction signal. The computational effort of the decoder 2 depends on the prediction orders chosen by the encoder 1. In most cases, real-time decoding is possible even on low-end systems.

FIG. 3 is an example illustration of a bitstream structure of
25 a compressed audio signal including a plurality of channels

(e.g., M channels) according to the present invention.

The bitstream consists of at least one audio frame including a plurality of channels (e.g., M channels). The "channels" field in the bitstream configuration syntax (see Table 6 below) indicates the number of channels. Each channel is subdivided into a plurality of blocks using the block switching scheme according to present invention, which will be described in detail later. Each sub-divided block has a different size and includes coding data according to the encoding of FIG.1.

For example, the coding data within a subdivided block contains the code indices, the prediction order K , the predictor coefficients, and the coded residual values. If joint coding between channel pairs is used, the block partition is identical for both channels, and blocks are stored in an interleaved fashion. A "js_stereo" field in the bitstream configuration syntax (Table 6) indicates whether joint stereo (channel difference) is on or off, and a "js_switch" field in the frame_data syntax (See Table 7 below) indicates whether joint stereo (channel difference) is selected. Otherwise, the block partition for each channel is independent.

Hereinafter, the block switching, random access, prediction, and entropy coding options previously mentioned will now be described in detail with reference to the accompanying drawings and syntaxes that follow.

Block Switching

An aspect of the present invention relates to subdividing each channel into a plurality of blocks prior to using the actual coding scheme. Hereinafter, the block partitioning (or subdividing) method according to the present invention will be referred to as a "block switching method".

Hierarchical Block Switching

FIG. 4 is an example illustration of a conceptual view of a hierarchical block switching method according to the present invention. For example, FIG. 4 illustrates a method of hierarchically subdividing one channel into 32 blocks. When a plurality of channels is provided in a single frame, each channel may be subdivided (or partitioned) to up to 32 blocks, and the subdivided blocks for each channel configure a frame. Accordingly, the block switching method according to the present invention is performed by the partitioning part 100 shown in FIG. 1. Furthermore, as described above, the prediction and entropy coding are performed on the subdivided block units.

In general, conventional Audio Lossless Coding (ALS) includes a relatively simple block switching mechanism. Each channel of N samples is either encoded using one full length block ($N_B = N$) or four blocks of length $N_B = N/4$ (e.g., 1:4

switching), where the same block partition applies to all channels. Under some circumstances, this scheme may have some limitations. For example, while only 1:1 or 1:4 switching may be possible, different switching (e.g., 1:2, 1:8, and combinations thereof) may be more efficient in some cases. Also in conventional ALS, switching is performed identically for all channels, although different channels may benefit from different switching (which is especially true if the channels are not correlated).

Therefore, the block switching method according to embodiments of the present invention provide relatively flexible block switching schemes, where each channel of a frame may be hierarchically subdivided into a plurality of blocks. For example, FIG. 4 illustrates a channel which can be hierarchically subdivided to up to 32 blocks. Arbitrary combinations of blocks with $N_B = N, N/2, N/4, N/8, N/16,$ and $N/32$ may be possible within a channel according to the presented embodiments, as long as each block results from a subdivision of a superordinate block of double length. For example, as illustrated in the example shown in FIG. 4, a partition into $N/4 + N/4 + N/2$ may be possible, while a partition into $N/4 + N/2 + N/4$ may not be possible (e.g., block switching examples shown in FIGs. 5(e) and 5 described below). Stated another way, the channel is divided into the plurality of blocks such that each block has a length equal to

one of,

$$N/(m^i) \quad \text{for } i = 1, 2, \dots p,$$

5 where N is the length of the channel, m is an integer greater than or equal to 2, and p represents a number of the levels in the subdivision hierarchy.

Accordingly, in embodiments of the present invention, a bitstream includes information indicating block switching
10 levels and information indicating block switching results. Herein, the information related to block switching is included in the syntax, which is used in the decoding process, described in detail below.

For example, settings are made so that a minimum block size
15 generated after the block switching process is $N_B = N/32$. However, this setting is only an example for simplifying the description of the present invention. Therefore, settings according to the present invention are not limited to this setting.

20 More specifically, when the minimum block size is $N_B = N/32$, this indicates that the block switching process has been hierarchically performed 5 times, which is referred to as a level 5 block switching. Alternatively, when the minimum block size is $N_B = N/16$, this indicates that the block

switching process has been hierarchically performed 4 times, which is referred to as a level 4 block switching. Similarly, when the minimum block size is $N_B = N/8$, the block switching process has been hierarchically performed 3 times, which is referred to as a level 3 block switching. And, when the minimum block size is $N_B = N/4$, the block switching process has been hierarchically performed 2 times, which is referred to as a level 2 block switching. When the minimum block size is $N_B = N/2$, the block switching process has been hierarchically performed 1 time, which is referred to as a level 1 block switching. Finally, when the minimum block size is $N_B = N$, the hierarchical block switching process has not been performed, which is referred to as a level 0 block switching.

In embodiments of the present invention, the information indicating the block switching level will be referred to as a first block switching information. For example, the first block switching information may be represented by a 2-bit "block_switching" field within the syntax shown in Table 6, which will be described in a later process. More specifically, "block_switching = 00" signifies level 0, "block_switching = 01" signifies any one of level 1 to level 3, "block_switching = 10" signifies level 4, and "block_switching = 11" signifies level 5.

Additionally, information indicating the results of the block

switching performed for each hierarchical level in accordance with the above-described block switching levels is referred to in the embodiments as second block switching information. Herein, the second block switching information may be
5 represented by a "bs_info" field which is expressed by any one of 8 bits, 16 bits, and 32 bits within the syntax shown in Table 7. More specifically, if "block_switching = 01" (signifying any one of level 1 to level 3), "bs_info" is expressed as 8 bits. If "block_switching = 10" (signifying
10 level 4), "bs_info" is expressed as 16 bits. In other words, up to 4 levels of block switching results may be indicated by using 16 bits. Furthermore, if "block_switching = 11" (signifying level 5, "bs_info" is expressed as 32 bits. In other words, up to 5 levels of block switching results may be
15 indicated by using 32 bits. Finally, if "block_switching = 00" (signifying that the block switching has not been performed), "bs_info" is not transmitted. This signifies that one channel configures one block.

The total number of bits being allocated for the second block
20 switching information is decided based upon the level value of the first block switching information. This may result in reducing the final bit rate. The relation between the first block switching information and the second block switching information is briefly described in Table 1 below.

Table 1: Block switching levels.

Maximum #levels	Minimum N_B	#Bytes for "bs_info"
0 ("block_switching=00")	N	0
1 ("block_switching=01")	N/2	1 (=8bits)
2 ("block_switching=01")	N/4	1 (=8bits)
3 ("block_switching=01")	N/8	1 (=8bits)
4 ("block_switching=10")	N/16	2 (=16bits)
5 ("block_switching=11")	N/32	4 (=32bits)

Hereinafter, an embodiment of a method of configuring (or mapping) each bit within the second block switching information (bs_info) will now be described in detail.

The bs_info field may include up to 4 bytes in accordance with the above-described embodiments. The mapping of bits with respect to levels 1 to 5 may be [(0)1223333 44444444 55555555 55555555]. The first bit may be reserved for indicating independent or synchronous block switching, which is described in more detail below in the Independent/Synchronous Block Switching section. FIGs. 5(a)-5(f) illustrate different block switching examples for a channel where level 3 block switching may take place. Therefore, in these examples, the minimum block length is $N_B = N/8$, and the bs_info consists of one byte.

Starting from the maximum block length $N_B = N$, the bits of bs_info are set if a block is further subdivided. For example, in FIG. 5(a), there is no subdivision at all, thus "bs_info" is (0)000 0000. In FIG. 5(b), the frame is subdivided ((0)1...) and the second block of length $N/2$ is further split ((0)101...) into two blocks of length $N/4$; thus "bs_info" is (0)1010 0000. In FIG. 5(c), the frame is subdivided ((0)1...), and only the first block of length $N/2$ is further split ((0)110...) into two blocks of length $N/4$; thus "bs_info" is (0)1100 0000. In FIG. 5(d), the frame is subdivided ((0)1...), the first and second blocks of length $N/2$ is further split ((0)111...) into two blocks of length $N/4$, and only the second block of length $N/4$ is further split ((0)11101...) into two blocks of length $N/8$; thus "bs_info" is (0)111 0100.

As discussed above, the examples in FIGs. 5(e) and 5(f) represent cases of block switching that are not permitted because the $N/2$ block in FIG. 5(e) and the first $N/4$ block in FIG. 5(f) could not have been obtained by subdividing a block of the previous level.

20

Independent / Synchronous Block Switching

FIGs. 6(a) - 6(c) are example illustrations of block switching according to embodiments of the present invention.

More specifically, FIG. 6(a) illustrates an example where block switching has not been performed for channels 1, 2, and

25

3. FIG. 6(b) illustrates an example in which two channels (channels 1 and 2) configure one channel pair, and block switching is performed synchronously in channels 1 and 2. Interleaving is also applied in this example. FIG. 6(c) illustrates an example in which two channels (channels 1 and 2) configure one channel pair, and the block switching of channels 1 and 2 is performed independently. Herein, the channel pair refers to two arbitrary audio channels. The decision on which channels are grouped into channel pairs can be made automatically by the encoder or manually by the user. (e.g., L and R channels, Ls and Rs channels).

In independent block switching, while the length of each channel may be identical for all channels, the block switching can be performed individually for each channel. Namely, as shown in FIG. 6(c), the channels may be divided into blocks differently. If the two channels of a channel pair are correlated with each other and difference coding is used, both channels of a channel pair may be block switched synchronously. In synchronous block switching, the channels are block switched (i.e., divided into blocks) in the same manner. FIG. 6(b) illustrates an example of this, and further illustrates that the blocks may be interleaved. If the two channels of a channel pair are not correlated with each other, difference coding may not provide a benefit, and thus there will be no need to block switch the channels synchronously. Instead, it

may be more appropriate to switch the channels independently.

Furthermore, according to another embodiment of the present invention, the described method of independent or synchronous

block switching may be applied to a multi-channel group having

5 a number of channels equal to or more than 3 channels. For

example, if all channels of a multi-channel group are

correlated with each other, all channels of a multi-channel

group may be switched synchronously. On the other hand, if all

channels of a multi-channel group are not correlated with each

10 other, each channel of the multi-channel group may be switched

independently.

Moreover, the "bs_info" field is used as the information for

indicating the block switching result. Additionally, the

"bs_info" field is also used as the information for indicating

15 whether block switching has been performed independently or

performed synchronously for each channel configuring the

channel pair. In this case, as described above, a particular

bit (e.g., first bit) within the "bs_info" field may be used.

If, for example, the two channels of the channel pair are

20 independent from one another, the first bit of the "bs_info"

field is set to "1". On the other hand, if the two channels

of the channel pair are synchronous to one another, the first

bit of the "bs_info" field is set as "0".

Hereinafter, FIGs. 6(a), 6(b), and 6(c) will now be described

25 in detail.

Referring to FIG. 6(a), since none of the channels perform block switching, the related "bs_info" is not generated.

Referring to FIG. 6(b), channels 1 and 2 configure a channel pair, wherein the two channels are synchronous to one another,

5 and wherein block switching is performed synchronously. For example, in FIG. 6(b), both channels 1 and 2 are split into blocks of length $N/4$, both having the same bs_info "bs_info = (0)101 0000". Therefore, one "bs_info" may be transmitted for each channel pair, which results in reducing the bit rate.

10 Furthermore, if the channel pair is synchronous, each block within the channel pair may be required to be interleaved with one another. The interleaving may be beneficial (or advantageous). For example, a block of one channel (e.g., block 1.2 in FIG. 6(b)) within a channel pair may depend on
15 previous blocks from both channels (e.g., blocks 1.1 and 2.1 in FIG. 6(b)), and so these previous blocks should be available prior to the current one.

Referring to FIG. 6(c), channels 1 and 2 configure a channel pair. However, in this example, block switching is performed

20 independently. More specifically, channel 1 is split into blocks of a size (or length) of up to $N/4$ and has a bs_info of "bs_info = (1)101 0000". Channel 2 is split into blocks of a size of up to $N/2$ and has a bs_info of "bs_info = (1)100 0000".

In the example shown in FIG. 6(c), block switching is
25 performed independently among each channel, and therefore, the

interleaving process between the blocks is not performed. In other words, for the channel having the blocks switched independently, channel data may be arranged separately.

5 Joint Channel Coding

Joint channel coding, also called joint stereo, can be used to exploit dependencies between two channels of a stereo signal, or between any two channels of a multi-channel signal. While it is straightforward to process two channels $x_1(n)$ and $x_2(n)$ independently, a simple method of exploiting dependencies between the channels is to encode the difference signal:

$$d(n) = x_2(n) - x_1(n)$$

15 instead of $x_1(n)$ or $x_2(n)$. Switching between $x_1(n)$, $x_2(n)$ and $d(n)$ in each block may be carried out by comparison of the individual signals, depending on which two signals can be coded most efficiently. Such prediction with switched difference coding is advantageous in cases where
20 two channels are very similar to one another. In case of multi-channel material, the channels can be rearranged by the encoder in order to assign suitable channel pairs.

Besides simple difference coding, lossless audio codec also supports a more complex scheme for exploiting inter-channel

redundancy between arbitrary channels of multi-channel signals.

Random Access

The present invention relates to audio lossless coding and is
5 able to supports random access. Random access stands for fast
access to any part of the encoded audio signal without costly
decoding of previous parts. It is an important feature for
applications that employ seeking, editing, or streaming of the
compressed data. In order to enable random access, within a
10 random access unit, the encoder needs to insert a frame that
can be decoded without decoding previous frames. The inserted
frame is referred to as a "random access frame". In such a
random access frame, no samples from previous frames may be
used for prediction.

15 Hereinafter, the information for random access according to
the present invention will be described in detail. Referring
to the configuration syntax (shown in Table 6), information
related with random access are transmitted as configuration
information. For example, a "random_access" field is used as
20 information for indicating whether random access is allowed,
which may be represented by using 8 bits. Furthermore, if
random access is allowed, the 8-bit "random_access" field
designates the number of frames configuring a random access
unit. For example, when "random_access = 0000 0000", the
25 random access is not supported. In other words, when

"random_access > 0", random access is supported. More specifically, when "random_access = 0000 0001", this indicates that the number of frames configuring the random access unit is 1. This signifies that random access is allowed in all
5 frame units. Furthermore, when "random_access = 1111 1111", this indicates that the number of frames configuring the random access unit is 255. Accordingly, the "random_access" information corresponds to a distance between a random access
10 access frame within the current random access unit and a random access frame within the next random access unit. Herein, the distance is expressed by the number of frames.

A 32-bit "ra_unit_size" field is included in the bitstream and transmitted. Herein, the "ra_unit_size" field indicates the size from the current random access frame to the next random
15 access frame in byte units. Accordingly, the "ra_unit_size" field is either included in the configuration syntax (Table 6) or included in the frame-data syntax (Table 7). The configuration syntax (Table 6) may further include information indicating a location where the "ra_unit_size" information is
20 stored within the bitstream. This information is represented as a 2-bit "ra_flag" field. More specifically, for example, when "ra_flag = 00", this indicates that the "ra_unit_size" information is not stored in the bitstream. When the "ra_flag = 01", this indicated that the "ra_unit_size" information is
25 stored in the frame-data syntax (Table 7) within the bitstream.

Furthermore, when the "ra_flag = 10", the "ra_unit_size" information is stored in the configuration syntax (Table 6) within the bitstream. If the "ra_unit_size" information is included in the configuration syntax, this indicates that the "ra_unit_size" information is transmitted on the bitstream only one time and is applied equally to all random access units. Alternatively, if the "ra_unit_size" information is included in the frame-data syntax, this indicates the distance between the random access frame within the current random access unit and the random access frame within the next random access unit. Therefore, the "ra_unit_size" information is transmitted for each random access unit within the bitstream. Accordingly, the "random_access" field within the configuration syntax (Table 6) may also be referred to as first general information. And, the "ra_flag" field may also be referred to as second general information. In this aspect of the present invention, an audio signal includes configuration information and a plurality of random access units, each random access unit containing one or more audio data frames, one of which is a random access frame, wherein the configuration information includes first general information indicating a distance between two adjacent random access frames in frames, and second general information indicating where random access unit size information for each random access unit is stored. The random access unit size

information indicating a distance between two adjacent random access frames in bytes.

Alternatively, in this aspect of the present invention, a method of decoding an audio signal includes receiving the audio signal having configuration information and a plurality of random access units, each random access unit containing one or more audio data frames, one of which is a random access frame, reading first general information from the configuration information, the first general information indicating a distance between two adjacent random access frames in frames, and reading second general information from the configuration information, the second general information indicating where random access size information for each random access unit is stored, and the random access unit size information indicating a distance between two adjacent random access frames in bytes.

Channel configuration

As shown in FIG. 3, an audio signal includes multi-channels information according to the present invention. For example, each channel may be mapped at a one-to-one correspondence with a location of an audio speaker. The configuration syntax (Table 6 below) includes channel configuration information, which is indicated as a 16-bit "chan_config_info" field and a 16-bit "channels" field. The "chan_config_info" field includes

information for mapping the channels to the loudspeaker locations and the 16-bit "channels" field includes information indicating the total number of channels. For example, when the "channels" field is equal to "0", this indicates that the channel corresponds to a mono channel. When the "channels" field is equal to "1", this indicates that the channel corresponds to one of stereo channels. And, when the "channels" field is equal to or more than "2", this indicates that the channel corresponds to one of multi-channels.

Table 2 below shows examples of each bit configuring the "chan_config_info" field and each respective channel corresponding thereto. More specifically, when a corresponding channel exists within the transmitted bitstream, the corresponding bit within the "chan_config_info" field is set to "1". Alternatively, when a corresponding channel does not exist within the transmitted bitstream, the corresponding bit within the "chan_config_info" field is set to "0". The present invention also includes information indicating whether the "chan_config_info" field exists within the configuration syntax (Table 6). This information is represented as a 1-bit "chan_config" flag. More specifically, "chan_config = 0" indicates that the "chan_config_info" field does not exist. And, "chan_config = 1" indicates that the "chan_config_info" field exists. Therefore, when "chan_config = 0", this indicates that the "chan_config_info" field is not newly

defined within the configuration syntax (Table 6).

Table 2: Channel configuration.

Speaker location	Abbreviation	Bit position in chan_config_info
Left	L	1
Right	R	2
Left Rear	Lr	3
Right Rear	Rr	4
Left Side	Ls	5
Right Side	Rs	6
Center	C	7
Center Rear / Surround	S	8
Low Frequency Effects	LFE	9
Left Downmix	L0	10
Right Downmix	R0	11
Mono Downmix	M	12
(reserved)		13-16

5

Frame length

As shown in FIG. 3, an audio signal includes multiple or multi-channels according to the present invention. Therefore, when performing encoding, information on the number of multi-channels configuring one frame and information on the number of samples for each channel are inserted in the bitstream and transmitted. Referring to the configuration syntax (Table 6), a 32-bit "samples" field is used as information indicating the

total number of audio data samples configuring each channel. Further, a 16-bit "frame_length" field is used as information indicating the number of samples for each channel within the corresponding frame.

5 Furthermore, a 16-bit value of the "frame_length" field is determined by a value used by the encoder, and is referred to as a user-defined value. In other words, instead of being a fixed value, the user-defined value is arbitrarily determined upon the encoding process.

10 Therefore, during the decoding process, when the bitstream is received through the demultiplexing part 200 of shown in FIG. 2, the frame number of each channel should first be obtained. This value is obtained according to the algorithm shown below.

```
15     frames = samples / frame_length;
        rest = samples % frame_length;
        if (rest)
        {
            frames++;
20     frlen_last = rest;
        }
        else
            frlen_last = frame_length;
```

25 More specifically, the total number of frames for each channel

is calculated by dividing the total number of samples for each channel, which is decided by the "samples" field transmitted through the bitstream, by the number of samples within a frame of each channel, which is decided by the "frame_length" field.

5 For example, when the total number of samples decided by the "samples" field is an exact multiple of the number of samples within each frame, which is decided by the "frame_length" field, the multiple value becomes the total number of frames. However, if the total number of samples decided by the
10 "samples" field is not an exact multiple of the number of samples decided by the "frame_length" field, and a remainder (or rest) exist, the total number of frames increases by "1" more than the multiple value. Furthermore, the number of samples of the last frame (frlen_last) is decided as the
15 remainder (or rest). This indicates that only the number of samples of the last frame is different from its previous frame. By defining a standardized rule between the encoder and the decoder, as described above, the encoder may freely decide and transmit the total number of samples ("samples" field) for
20 each channel and the number of samples("frame_length" field) within a frame of each channel. Furthermore, the decoder may accurately decide, by using the above-described algorithm on the transmitted information, the number of frames for each channel that is to be used for decoding.

Linear Prediction

In the present invention, linear prediction is applied for the lossless audio coding. The predictor 160 shown in FIG. 1 includes at least one or more filter coefficients so as to predict a current sample value from a previous sample value. Then, the second entropy coding part 180 performs entropy coding on a residual value corresponding to the difference between the predicted value and the original value. Additionally, the predictor coefficient values for each block that are applied to the predictor 160 are selected as optimum values from the coefficient estimating part 120. Further, the predictor coefficient values are entropy coded by the first entropy coding part 140. The data coded by the first entropy coding part and the second entropy coding part 180 are inserted as part of the bitstream by the multiplexing part 190 and then transmitted.

Hereinafter, the method of performing linear prediction according to the present invention will now be described in detail.

20

Prediction with FIR Filters

Linear prediction is used in many applications for speech and audio signal processing. Hereinafter, an exemplary operation of the predictor 160 will be described based on Finite Impulse Response (FIR) filters. However, it is apparent that this

25

example will not limit the scope of the present invention.

The current sample of a time-discrete signal $x(n)$ can be approximately predicted from previous samples $x(n-k)$. The prediction is given by the following equation.

5

$$\hat{x}(n) = \sum_{k=1}^K h_k * x(n-k),$$

wherein K is the order of the predictor. If the predicted samples are close to the original samples, the residual shown below:

10

$$e(n) = x(n) - \hat{x}(n)$$

15

has a smaller variance than $x(n)$ itself, hence $e(n)$ can be encoded more efficiently.

20

The procedure of estimating the predictor coefficients from a segment of input samples, prior to filtering that segment is referred to as forward adaptation. In this case, the coefficients should be transmitted. On the other hand, if the coefficients are estimated from previously processed segments or samples, e.g., from the residual, reference is made to backward adaptation. The backward adaptation procedure has the advantage that no transmission of the coefficients is needed, since the data required to estimate the coefficients

is available to the decoder as well.

Forward-adaptive prediction methods with orders around 10 are widely used in speech coding, and can be employed for lossless audio coding as well. The maximum order of most forward-adaptive lossless prediction schemes is still rather small, e.g., $K = 32$. An exception is the special 1-bit lossless codec for the Super Audio CD, which uses prediction orders of up to 128.

On the other hand, backward-adaptive FIR filters with some hundred coefficients are commonly used in many areas, e.g., channel equalization and echo cancellation. Most of these systems are based on the LMS algorithm or a variation thereof, which has also been proposed for lossless audio coding. Such LMS-based coding schemes with high orders are applicable since the predictor coefficients do not have to be transmitted as side information, thus their number does not contribute to the data rate. However, backward-adaptive codecs have the drawback that the adaptation has to be carried out both in the encoder and the decoder, making the decoder significantly more complex than in the forward-adaptive case.

Forward-Adaptive Prediction

As an exemplary embodiment of the present invention, forward adaptive prediction will be given as an example in the description set forth herein. In forward-adaptive linear

prediction, the optimal predictor coefficients h_k (in terms of a minimized variance of the residual) are usually estimated for each block by the coefficient estimating part 120 using the autocorrelation method or the covariance method. The autocorrelation method, using the conventional Levinson-Durbin algorithm, has the additional advantage of providing a simple means to iteratively adapt the order of the predictor. Furthermore, the algorithm inherently calculates the corresponding parcor coefficients as well.

Another aspect of forward-adaptive prediction is to determine a suitable prediction order. Increasing the order decreases the variance of the prediction error, which leads to a smaller bit rate R_e for the residual. On the other hand, the bit rate R_c for the predictor coefficients will rise with the number of coefficients to be transmitted. Thus, the task is to find the optimum order which minimizes the total bit rate. This can be expressed by minimizing the equation below:,

$$R_{total}(K) = R_e(K) + R_c(K),$$

20

with respect to the prediction order K . As the prediction gain rises monotonically with higher orders, R_e decreases with K . On the other hand R_c rises monotonically with K , since an increasing number of coefficients should be transmitted.

The search for the optimum order can be carried out efficiently by the coefficient estimating part 120, which determines recursively all predictors with increasing order. For each order, a complete set of predictor coefficients is
5 calculated. Moreover, the variance σ_e^2 of the corresponding residual can be derived, resulting in an estimate of the expected bit rate for the residual. Together with the bit rate for the coefficients, the total bit rate can be determined in each iteration, i.e., for each prediction order.
10 The optimum order is found at the point where the total bit rate no longer decreases.

While it is obvious from the above equation that the coefficient bit rate has a direct effect on the total bit rate, a slower increase of R_e also allows to shift the minimum of
15 R_{total} to higher orders (wherein R_e is smaller as well), which would lead to better compression. Hence, efficient yet accurate quantization of the predictor coefficients plays an important role in achieving maximum compression.

20 Prediction orders

In the present invention, the prediction order K , which decides the number of predictor coefficients for linear prediction, is determined. The prediction order K is also determined by the coefficient estimating part 120. Herein,

information on the determined prediction order is included in the bitstream and then transmitted.

The configuration syntax (Table 6) includes information related to the prediction order K . For example, a 1-bit to 10-bit "max_order" field corresponds to information indicating a maximum order value. The highest value of the 1-bit to 10-bit "max_order" field is $K=1023$ (e.g., 10-bit). As another information related to the prediction order K , the configuration syntax (Table 6) includes a 1-bit "adapt_order" field, which indicates whether an optimum order for each block exists. For example, when "adapt_order = 1", an optimum order should be provided for each block. In a block_data syntax (Table 8), the optimum order is provided as a 1-bit to 10-bit "opt_order" field. Further, when "adapt_order = 0", a separate optimum order is not provided for each block. In this case, the "max_order" field becomes the final order applied to all of the blocks.

The optimum order (opt_order) is decided based upon the value of max_order field and the size (N_B) of the corresponding block. More specifically, for example, when the max_order is decided as $K_{max} = 10$ and "adapt_order = 1", the opt_order for each block may be decided considering the size of the corresponding block. In some case, the opt_order value being larger than max_order ($K_{max} = 10$) is possible.

In particular, the present invention relates to higher

prediction orders. In the absence of hierarchical block switching, there may be a factor of 4 between the long and the short block length (e.g. 4096 & 1024 or 8192 & 2048), in accordance with the embodiments. On the other hand, in the 5 embodiments where hierarchical block switching is implemented, this factor can be increased (e.g., up to 32), enabling a larger range (e.g., 16384 down to 512 or even 32768 to 1024 for high sampling rates).

In the embodiments where hierarchical block switching is 10 implemented, in order to make better use of very long blocks, higher maximum prediction orders may be employed. The maximum order may be $K_{\max} = 1023$. In the embodiments, K_{\max} may be bound by the block length N_B , for example, $K_{\max} < N_B / 8$ (e.g., $K_{\max} = 255$ for $N_B = 2048$). Therefore, using $K_{\max} = 1023$ may require a 15 block length of at least $N_B = 8192$. In the embodiments, the "max_order" field in the configuration syntax (Table 6) can be up to 10 bits and "opt_order" field in the block_data syntax (Table 8) can also be up to 10 bits. The actual number of bits in a particular block may depend on the maximum order 20 allowed for a block. If the block is short, a local prediction order may be smaller than a global prediction order. Herein, the local prediction order is determined from considering the corresponding block length N_B , and the global prediction order is determined from the "max_order" K_{\max} in the

configuration syntax. For example, if $K_{\max} = 1023$, but $N_B = 2048$, the "opt_order" field is determined on 8 bits (instead of 10) due to a local prediction order of 255.

More specifically, the opt_order may be determined based on
 5 the following equation:

$$\text{opt_order} = \min(\text{global prediction order, local prediction order});$$

10 And, the global and local prediction orders may be determined by:

$$\text{global prediction order} = \text{ceil}(\log_2(\text{maximum prediction order} + 1))$$

15

$$\text{local prediction order} = \max(\text{ceil}(\log_2((N_b \gg 3) - 1)), 1)$$

In the embodiments, data samples of the subdivided block from a channel are predicted. A first sample of a current block is
 20 predicted using the last K samples of a previous block. The K value is determined from the opt_order which is derived from the above-described equation.

If the current block is a first block of the channel, no samples from the previous block are used. In this case,
 25 prediction with progressive order is employed. For example,

assuming that the `opt_order` value is $K=5$ for a corresponding block, the first sample in the block does not perform prediction. The second sample of the block uses the first sample of the block to perform the prediction (as like $K=1$),
5 the third sample of the block uses the first and second samples of the block to perform the prediction (as like $K=2$), etc. Therefore, starting from the sixth sample and for samples thereafter, prediction is performed according to the `opt_order` of $K=5$. As described above, the prediction order
10 increases progressively from $K=1$ to $K=5$.

The above-described progressive order type of prediction is very advantageous when used in the random access frame. Since the random access frame corresponds to a reference frame of the random access unit, the random access frame does not
15 perform prediction by using the previous frame sample. Namely, this progressive prediction technique may be applied at the beginning of the random access frame.

Quantization of Predictor Coefficients

20 The above-described predictor coefficients are quantized in the quantizing part 130 of FIG. 1. Direct quantization of the predictor coefficients h_k is not very efficient for transmission, since even small quantization errors may result in large deviations from the desired spectral characteristics
25 of the optimum prediction filter. For this reason, the

quantization of predictor coefficients is based on the parcor
(reflection) coefficients r_k , which can be calculated by the
coefficient estimating part 120. As described above, for
example, the coefficient estimating part 120 is processed
5 using the conventional Levinson-Durbin algorithm.

The first two parcor coefficients (γ_1 and γ_2 correspondingly)
are quantized by using the following functions:

$$a_1 = \left\lfloor 64 \left(-1 + \sqrt{2\sqrt{\gamma_1 + 1}} \right) \right\rfloor;$$
$$a_2 = \left\lfloor 64 \left(-1 + \sqrt{2\sqrt{-\gamma_2 + 1}} \right) \right\rfloor;$$

10 while the remaining coefficients are quantized using simple 7-
bit uniform quantizers:

$$a_k = \left\lfloor 64 \gamma_k \right\rfloor; \quad (k > 2).$$

In all cases the resulting quantized values a_k are restricted
to the range $[-64, 63]$.

15

Entropy Coding

As shown in FIG. 1, two types of entropy coding are applied in
the present invention. More specifically, the first entropy
coding part 140 is used for coding the above-described
20 predictor coefficients. And, the second entropy coding part
180 is used for coding the above-described audio original
samples and audio residual samples. Hereinafter, the two

types of entropy coding will now be described in detail.

First Entropy Coding of the predictor coefficient

The related art Rice code is used as the first entropy coding
5 method according to the present invention. For example,
transmission of the quantized coefficients a_k is performed by
producing residual values:

$$\delta_k = a_k - \text{offset}_k,$$

10

which, in turn, are encoded by using the first entropy coding
part 140, e.g., the Rice code method. The corresponding
offsets and parameters of Rice code used in this process can
be globally chosen from one of the sets shown in Table 3, 4
15 and 5 below. A table index (i.e., a 2-bit "coef_table") is
indicated in the configuration syntax (Table 6). If
"coef_table = 11", this indicates that no entropy coding is
applied, and the quantized coefficients are transmitted with 7
bits each. In this case, the offset is always -64 in order to
20 obtain unsigned values $\delta_k = a_k + 64$ that are restricted to
[0,127]. Conversely, if "coeff_table = 00", Table 3 below is
selected, and if "coeff_table = 01", Table 4 below is selected.
Finally, if "coeff_table = 11", Table 5 is selected.

When receiving the quantized coefficients in the decoder of

FIG.2, the first entropy decoding part 220 reconstructs the predictor coefficients by using the process that the residual values δ_k are combined with offsets to produce quantized indices of parcor coefficients a_k :

5

$$a_k = \delta_k + \text{offset}_k .$$

Thereafter, the reconstruction of the first two coefficients (γ_1 and γ_2) is performed by using:

10

$$\begin{aligned} \text{par}_1 &= \lfloor \hat{\gamma}_1 2^Q \rfloor = \Gamma(a_1); \\ \text{par}_2 &= \lfloor \hat{\gamma}_2 2^Q \rfloor = -\Gamma(a_2); \end{aligned}$$

wherein 2^Q represents a constant ($Q=20$) scale factor required for integer representation of the reconstructed coefficients, and $\Gamma(\cdot)$ is an empirically determined mapping table (not shown as the mapping table may vary with implementation).

15 Accordingly, the three types of coefficient tables used for the first entropy coding are provided according to the sampling frequency. For example, the sampling frequency may be divided to 48kHz, 96kHz, and 192kHz. Herein, each of the three Tables 3, 4, and 5 is respectively provided for each
20 sampling frequency.

Instead of using a single table, one of three different tables can be chosen for the entire file. The table should

typically be chosen depending on the sampling rate. For material with 44.1 kHz, the applicant of the present invention recommends to use the 48 kHz table. However, in general, the table can also be chosen by other criteria.

5

Table 3: Rice code parameters used for encoding of quantized coefficients (48 kHz).

Coefficient #	Offset	Rice parameter
1	-52	4
2	-29	5
3	-31	4
4	19	4
5	-16	4
6	12	3
7	-7	3
8	9	3
9	-5	3
10	6	3
11	-4	3
12	3	3
13	-3	2
14	3	2
15	-2	2
16	3	2
17	-1	2
18	2	2
19	-1	2
20	2	2
$2k-1, k>10$	0	2
$2k, k>10$	1	2

10

Table 4: Rice code parameters used for encoding of quantized coefficients (96 kHz).

Coefficient #	Offset	Rice parameter
1	-58	3
2	-42	4
3	-46	4

4	37	5
5	-36	4
6	29	4
7	-29	4
8	25	4
9	-23	4
10	20	4
11	-17	4
12	16	4
13	-12	4
14	12	3
15	-10	4
16	7	3
17	-4	4
18	3	3
19	-1	3
20	1	3
$2k-1, k>10$	0	2
$2k, k>10$	1	2

Table 5: Rice code parameters used for encoding of quantized coefficients (192 kHz).

Coefficient #	Offset	Rice parameter
1	-59	3
2	-45	5
3	-50	4
4	38	4
5	-39	4
6	32	4
7	-30	4
8	25	3
9	-23	3
10	20	3
11	-20	3
12	16	3
13	-13	3
14	10	3
15	-7	3
16	3	3
17	0	3
18	-1	3
19	2	3
20	-1	2
$2k-1, k>10$	0	2

2k, k>10	1	2
----------	---	---

Second Entropy Coding of the Residual

The present invention contains two different modes of the coding method applied to the second entropy coding part 180 of FIG. 1, which will now be described in detail.

In the simple mode, the residual values $e(n)$ are entropy coded using Rice code. For each block, either all values can be encoded using the same Rice code, or the block can be further divided into four parts, each encoded with a different Rice code. The indices of the applied codes are transmitted, as shown in FIG. 1. Since there are different ways to determine the optimal Rice code for a given set of data, it is up to the encoder to select suitable codes depending upon the statistics of the residual.

Alternatively, the encoder can use a more complex and efficient coding scheme using BGMC mode. In the BGMC mode, the encoding of residuals is accomplished by splitting the distribution in two categories. The two types include residuals that belong to a central region of the distribution, $|e(n)| < e_{\max}$, and residuals that belong to its tails. The residuals in tails are simply re-centered (i.e., for $e(n) > e_{\max}$, $e_i(n) = e(n) - e_{\max}$ is provided) and encoded using Rice code as described above. However, in order to encode residuals in the

center of the distribution, the BGMC first splits the residuals into LSB and MSB components, then the BGMC encodes MSBs using block Gilbert-Moore (arithmetic) codes. And finally, the BGMC transmits LSBs using direct fixed-lengths
5 codes. Both parameters e_{\max} and the number of directly transmitted LSBs may be selected such that they only slightly affect the coding efficiency of this scheme, while allowing the coding to be significantly less complex.

The configuration syntax (Table 6) and the block_data syntax
10 (Table 8) according to the present invention include information related to coding of the Rice code and BGMC code. The information will now be described in detail

The configuration syntax (Table 6) first includes a 1-bit "bgmc_mode" field. For example, "bgmc_mode = 0" signifies the
15 Rice code, and "bgmc_mode = 1" signifies the BGMC code. The configuration syntax (Table 6) also includes a 1-bit "sb_part" field. The "sb_part" field corresponds to information related to a method of partitioning a block to a sub-block and coding the partitioned sub-block. Herein, the meaning of the
20 "sb_part" field varies in accordance with the value of the "bgmc_mode" field.

For example, when "bgmc_mode = 0", in other words when the Rice code is applied, "sb_part = 0" signifies that the block is not partitioned into sub-blocks. Alternatively, "sb_part =
25 1" signifies that the block is partitioned at a 1:4 sub-block

partition ratio. Additionally, when "bgmc_mode = 1", in other words when the BGMC code is applied, "sb_part = 0" signifies that the block is partitioned at a 1:4 sub-block partition ratio. Alternatively, "sb_part = 1" signifies that the block is partitioned at a 1:2:4:8 sub-block partition ratio.

The block_data syntax (Table 8) for each block corresponding to the information included in the configuration syntax (Table 6) includes 0-bit to 2-bit variable "ec_sub" fields. More specifically, the "ec_sub" field indicates the number of sub-blocks existing in the actual corresponding block. Herein, the meaning of the "ec_sub" field varies in accordance with the value of the "bgmc_mode" + "sb_part" fields within the configuration syntax (Table 6).

For example, "bgmc_mode + sb_part = 0" signifies that the Rice code does not configure the sub-block. Herein, the "ec_sub" field is a 0-bit field, which signifies that no information is included.

In addition, "bgmc_mode + sb_part = 1" signifies that the Rice code or the BGMC code is used to partition the block to sub-blocks at a 1:4 rate. Herein, only 1 bit is assigned to the "ec_sub" field. For example, "ec_sub = 0" indicates one sub-block (i.e., the block is not partitioned to sub-blocks), and "ec_sub = 1" indicates that 4 sub-blocks are configured.

Furthermore, "bgmc_mode + sb_part = 2" signifies that the BGMC code is used to partition the block to sub-blocks at a 1:2:4:8

rate. Herein, 2 bits are assigned to the "ec_sub" field. For example, "ec_sub = 00" indicates one sub-block (i.e., the block is not partitioned to sub-blocks), and, "ec_sub = 01" indicates 2 sub-blocks. Also, "ec_sub = 10" indicates 4 sub-blocks, and "ec_sub = 11" indicates 8 sub-blocks.

The sub-blocks defined within each block as described above are coded by second entropy coding part 180 using a difference coding method. An example of using the Rice code will now be described. For each block of residual values, either all values can be encoded using the same Rice code, or, if the "sb_part" field in the configuration syntax is set, the block can be partitioned into 4 sub-blocks, each encoded sub-block having a different Rice code. In the latter case, the "ec_sub" field in the block-data syntax (Table 8) indicates whether one or four blocks are used.

While the parameter $s[i = 0]$ of the first sub-block is directly transmitted with either 4 bits (resolution ≤ 16 bits) or 5 bits (resolution > 16 bits), only the differences ($s[i] - s[i-1]$) of following parameters $s[i > 0]$ are transmitted. These differences are additionally encoded using appropriately chosen Rice codes again. In this case, the Rice code parameter used for differences has the value of "0".

Syntax

According to the embodiment of the present invention, the

syntax of the various information included in the audio bitstream are shown in the tables below. Table 6 shows a configuration syntax for audio lossless coding. The configuration syntax may form a header periodically placed in the bitstream, may form a header of each frame; etc. Table 7 shows a frame-data syntax, and Table 8 shows a block-data syntax.

Table 6: Configuration syntax.

Syntax	Bits
ALSSpecificConfig()	
{	
samp_freq;	32
samples;	32
channels;	16
file_type;	3
resolution;	3
floating;	1
msb_first;	1
frame_length;	16
random_access;	8
ra_flag;	2
adapt_order;	1
coef_table;	2
long_term_prediction;	1
max_order;	10
block_switching;	2
bgmc_mode;	1
sb_part;	1
joint_stereo;	1
mc_coding;	1
chan_config;	1
chan_sort;	1
crc_enabled;	1
RLSLMS	1
(reserved)	6
if (chan_config) {	
chan_config_info;	16
}	
if (chan_sort) {	
for (c = 0; c < channels; c++)	

<pre> chan_pos[c]; } header_size; trailer_size; orig_header[]; orig_trailer[]; if (crc_enabled) { crc; } if ((ra_flag == 2) && (random_access > 0)) { for (f = 0; f < (samples - 1 / frame_length) + 1; f++) { ra_unit_size } } } } </pre>	<p>8</p> <p>16</p> <p>16</p> <p>header_size * 8</p> <p>trailer_size * 8</p> <p>32</p> <p>32</p>
--	---

Table 7: Frame_data syntax.

Syntax	Bits
<pre> frame_data() { if ((ra_flag == 1) && (frame_id % random_access == 0)) { ra_unit_size } if (mc_coding && joint_stereo) { js_switch; byte_align; } if (!mc_coding js_switch) { for (c = 0; c < channels; c++) { if (block_switching) { bs_info; } if (independent_bs) { for (b = 0; b < blocks; b++) { block_data(c); } } } } else{ for (b = 0; b < blocks; b++) { </pre>	<p>32</p> <p>1</p> <p>8, 16, 32</p>

<pre> } } else { js_block; if ((bgmc_mode == 0) && (sb_part == 0) { sub_blocks = 1; } else if ((bgmc_mode == 1) && (sb_part ==1) { ec_sub; sub_blocks = 1 << ec_sub; } else { ec_sub; sub_blocks = (ec_sub == 1) ? 4 : 1; } if (bgmc_mode == 0) { for (k = 0; k < sub_blocks; k++) { s[k]; } } else { for (k = 0; k < sub_blocks; k++) { s[k], sx[k]; } } sb_length = block_length / sub_blocks; shift_lsbs; if (shift_lsbs == 1) { shift_pos; } if (!IRLSLMS) { if (adapt_order == 1) { opt_order; } for (p = 0; p < opt_order; p++) { quant_cof[p]; } } } </pre>	<p>1</p> <p>2</p> <p>1</p> <p>varie s</p> <p>varie s</p> <p>1</p> <p>4</p> <p>1...10</p> <p>varie s</p>
---	---

Compression Results

In the following, the lossless audio codec is compared with

two of the most popular programs for lossless audio compression: the open-source codec FLAC and the Monkey's Audio (MAC 3.97). Herein, the open-source codec FLAC uses forward-adaptive prediction, and the Monkey's Audio (MAC 3.97) is a backward-adaptive codec used as the current state-of-the-art algorithm in terms of compression. Both codecs were run with options providing maximum compression (i.e., flac -8 and mac-c4000). The results for the encoder are determined for a medium compression level (with the prediction order restricted to K _ 60) and a maximum compression level (K _ 1023), both with random access of 500 ms. The tests were conducted on a 1.7 GHz Pentium-M system, with 1024 MB of memory. The test comprises nearly 1 GB of stereo waveform data with sampling rates of 48, 96, and 192 kHz, and resolutions of 16 and 24 bits.

Compression Ratio

In the following, the compression ratio is defined as:

$$C = \frac{\text{CompressedFileSize}}{\text{OriginalFileSize}} * 100\% ,$$

wherein smaller values indicate better compression. The results for the examined audio formats are shown in Table 9 (192 kHz material is not supported by the FLAC codec).

Table 9: Comparison of average compression ratios for different audio formats (kHz/bits).

Format	FLAC	MAC	ALS medium	ALS maximum
48/16	48.6	45.3	45.5	44.7
48/24	68.4	63.2	63.3	62.7
96/24	56.7	48.1	46.5	46.2
192/24	-	39.1	37.7	37.6
Total	-	48.9	48.3	47.8

5

The results show that ALS at maximum level outperforms both FLAC and Monkey's Audio for all formats, but particularly for high-definition material (i.e., 96 kHz / 24-bit and above). Even at medium level, ALS delivers the best overall compression.

10

Complexity

The complexity of different codecs strongly depends on the actual implementation, particularly that of the encoder. As mentioned above, the audio signal encoder of the present invention is an ongoing development. Thus, we restrict our analysis to the decoder, a simple C code implementation with no further optimizations. The compressed data were generated by the currently best encoder implementation. The average CPU load for real-time decoding of various audio formats, encoded

20

at different complexity levels, is shown in Table 10. Even for maximum complexity, the CPU load of the decoder is only around 20-25%, which in return means that file based decoding is at least 4 to 5 times faster than real-time.

5

Table 10 : Average CPU load (percentage on a 1.7 GHz Pentium-M), depending on audio format (kHz/bits) and ALS encoder complexity.

Format	ALS low	ALS medium	ALS maximum
48/16	1.6	4.9	18.7
48/24	1.8	5.8	19.6
96/24	3.6	12.0	23.8
192/24	6.7	22.8	26.7

10

The codec is designed to offer a large range of complexity levels. While the maximum level achieves the highest compression at the expense of slowest encoding and decoding speed, the faster medium level only slightly degrades compression, but decoding is significantly less complex than for the maximum level (i.e., approximately 5% CPU load for 48 kHz material). Using a low-complexity level (i.e., K _ 15, Rice coding) degrades compression by only 1 to 1.5% compared to the medium level, but the decoder complexity is further reduced by a factor of three (i.e., less than 2% CPU load for 48 kHz material). Thus, audio data can be decoded even on hardware with very low computing power.

20

While the encoder complexity may be increased by both higher maximum orders and a more elaborate block switching algorithm (in accordance with the embodiments), the decoder may be affected by a higher average prediction order.

5 The foregoing embodiments (e.g., hierarchical block switching) and advantages are merely examples and are not to be construed as limiting the appended claims. The above teachings can be applied to other apparatuses and methods, as would be appreciated by one of ordinary skill in the art. Many
10 alternatives, modifications, and variations will be apparent to those skilled in the art.

Industrial Applicability

It will be apparent to those skilled in the art that various
15 modifications and variations can be made in the present invention without departing from the spirit or scope of the inventions. For example, aspects and embodiments of the present invention can be readily adopted in another audio signal codec like the lossy audio signal codec. Thus, it is
20 intended that the present invention covers the modifications and variations of this invention.

[CLAIMS]

1. A method of processing an audio signal, comprising:

subdividing a channel in a frame of the audio signal
5 into a plurality of blocks according to a subdivision
hierarchy, the subdivision hierarchy having more than one
level, each level being associated with a different block
length, and at least two of the blocks having different
lengths;

10 generating first subdivision information indicating a
number of levels in the subdivision hierarchy; and

generating second subdivision information indicating the
subdivision of the channel into the blocks, a length of the
second subdivision information depending on the first
15 subdivision information.

2. The method of claim 1, further comprising:

including the first subdivision information in a header
of the audio signal.

20

3. The method of claim 2, wherein the first subdivision
information includes 2 bits.

4. The method of claim 1, wherein the first subdivision
25 information indicates whether the subdivision hierarchy

includes one of up to three levels, four levels, and five levels.

5. The method of claim 4, wherein

5 if the first subdivision information is 01, the first subdivision information indicates the subdivision hierarchy includes up to three levels;

if the first subdivision information is 10, the first subdivision information indicates the subdivision

10 hierarchy includes four levels;

if the first subdivision information is 11, the first subdivision information indicates the subdivision hierarchy includes five levels.

15 6. The method of claim 1, wherein a length of the second subdivision information is one of 8 bits, 16 bits and 32 bits.

7. The method of claim 1, wherein a length of the second subdivision information is 8 bits if the first subdivision

20 information indicates the subdivision hierarchy includes up to three levels.

8. The method of claim 1, wherein a length of the second subdivision information is 16 bits if the first subdivision

25 information indicates the subdivision hierarchy includes four

levels.

9. The method of claim 1, wherein a length of the second subdivision information is 32 bits if the first subdivision information indicates the subdivision hierarchy includes five
5 levels.

10. The method of claim 1, wherein a length of the second subdivision information is 8 bits if the subdivision hierarchy includes up to three levels.

10

11. The method of claim 1, wherein a length of the second subdivision information is 16 bits if the subdivision hierarchy includes four levels.

15 12. The method of claim 1, wherein a length of the second subdivision information is 32 bits if the subdivision hierarchy includes five levels.

13. The method of claim 1, further comprising:

20 including the second subdivision information in a header of the audio signal.

14. The method of claim 1, wherein the generating second subdivision information step generates the second subdivision
25 information such that the second subdivision information

includes a number of information bits, and the information bits indicate the subdivision of the channel into the blocks.

15. The method of claim 14, wherein each information bit is
5 associated with a level in the subdivision hierarchy and is associated with a block at the associated level, and each information bit indicates whether the associated block was subdivided.

10 16. The method of claim 15, wherein if the information bit has a value of 1, then the associated block is subdivided, and if the information bit has a value of 0, then the associated block is not subdivided.

15 17. The method of claim 1, further comprising:
 sending the first subdivision information.

18. The method of claim 1, further comprising:
 sending the second subdivision information.

20

19. The method of claim 1, further comprising:
 predicting current data samples in the channel based on previous data samples, a number of the previous data samples used in the predicting step being the prediction order; and
25 obtaining a residual of the current data samples based

on the predicted data samples.

20. The method of claim 19, wherein the predicting step progressively increases the prediction order to a desired
5 prediction order as previous data samples become available.

21. The method of claim 20, wherein
the prediction order for an initial data sample having no
previous data samples is zero, and the predicting step
10 generates zero as the predicted initial data sample; and
the obtaining step effectively does not change the
initial data sample as a result of the predicted initial
data sample being zero.

15 22. The method of claim 20, further comprising:
determining the desired prediction order for each block
based on a maximum permitted prediction order and a length of
the block.

20 23. The method of claim 19, further comprising:
determining an optimum prediction order for each block
based on a maximum permitted prediction order and a length of
the block.

25 24. The method of claim 23, wherein the determining step

comprises:

determining a global prediction order based on the maximum permitted prediction order;

determining a local prediction order based on the length
5 of the block; and

selecting a minimum one of the global prediction order and the local prediction order as the optimum prediction order.

25. The method of claim 19, wherein if the frame is a random
10 access frame, which is a frame to be encoded such that previous frames are not necessary to decode the frame,

the predicting step progressively increases the prediction order to a desired prediction order as previous data samples from only the random access frame
15 become available.

26. The method of claim 1, wherein a superordinate level of the subdivision hierarchy is associated with a block length double a block length associated with a subordinate level.

20

27. The method of claim 1, wherein the subdividing step selectively subdivides a block of the superordinate level to obtain two blocks at the subordinate level.

25 28. The method of claim 1, wherein if a channel has a length

of N , then the subdividing step subdivides the channel into the plurality of blocks such that each block has a length of one of $N/2$, $N/4$, $N/8$, $N/16$ and $N/32$.

5

29. The method of claim 1, wherein the subdividing step subdivides the channel into the plurality of blocks such that each block has a length equal to one of,

10 $N/(m^i)$ for $i = 1, 2, \dots, p,$

where N is the length of the channel, m is an integer greater than or equal to 2, and p represents a number of the levels in the subdivision hierarchy.

15

30. The method of claim 29, wherein $m = 2$ and $p = 5$.

31. A method of encoding an audio signal, comprising:

subdividing a channel in a frame of the audio signal
20 into a plurality of blocks according to a subdivision hierarchy, the subdivision hierarchy having more than one level, each level being associated with a different block length, and at least two of the blocks having different lengths;

25 generating first subdivision information indicating a

number of levels in the subdivision hierarchy;

generating second subdivision information indicating the subdivision of the channel into the blocks, a length of the second subdivision information depending on the first

5 subdivision information; and

encoding the plurality of blocks to produce a compressed bitstream that includes the first and second subdivision information.

10 32. A method of decoding an audio signal, comprising:

receiving an audio data frame having a channel subdivided into a plurality of blocks according to a subdivision hierarchy, the subdivision hierarchy having more than one level, each level being associated with a different
15 block length, and at least two of the blocks having different lengths;

obtaining first subdivision information indicating a number of levels in the subdivision hierarchy and second subdivision information indicating the subdivision of the
20 channel into the blocks, a length of the second subdivision information depending on the first subdivision information; and

decoding the channel based on the obtained first and second subdivision information.

33. An apparatus for encoding an audio signal, comprising:

an encoder configured to subdivide a channel in a frame of the audio signal into a plurality of blocks according to a subdivision hierarchy, the subdivision hierarchy having more than one level, each level being associated with a different block length, and at least two of the blocks having different lengths;

the encoder configured to generate first subdivision information indicating a number of levels in the subdivision hierarchy, and to generate second subdivision information indicating the subdivision of the channel into the blocks, a length of the second subdivision information depending on the first subdivision information; and

the encoder configured to encode the plurality of blocks to produce a compressed bitstream that includes the first and second subdivision information.

34. An apparatus for decoding an audio signal, comprising:

a decoder configured to receive an audio data frame having a channel subdivided into a plurality of blocks according to a subdivision hierarchy, the subdivision hierarchy having more than one level, each level being associated with a different block length, and at least two of the blocks having different lengths;

the decoder configured to obtain first subdivision

information indicating a number of levels in the subdivision hierarchy and second subdivision information indicating the subdivision of the channel into the blocks, a length of the second subdivision information depending on the first
5 subdivision information; and

the decoder configured to decode the channel based on the obtained first and second subdivision information.

FIG. 1

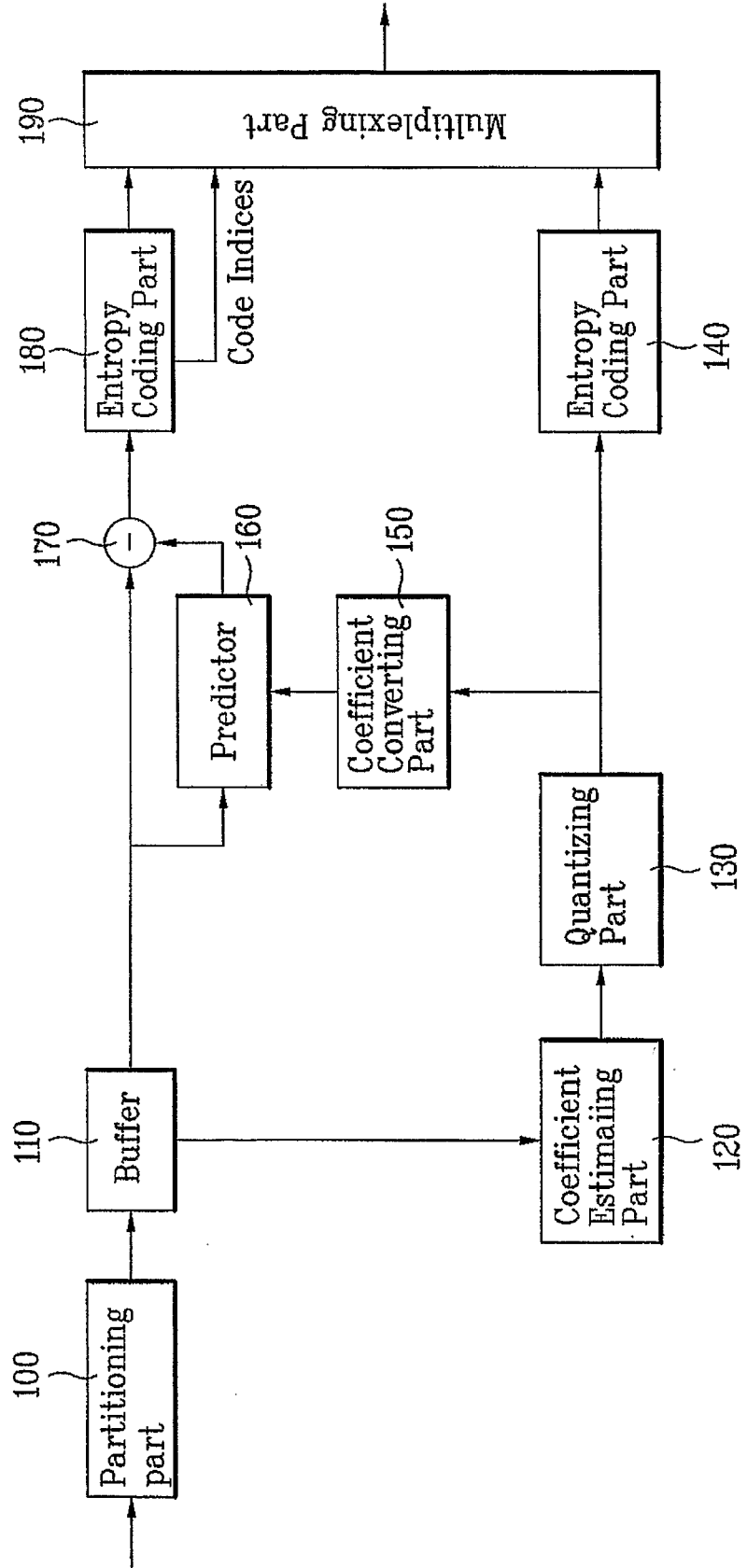

FIG. 2

2

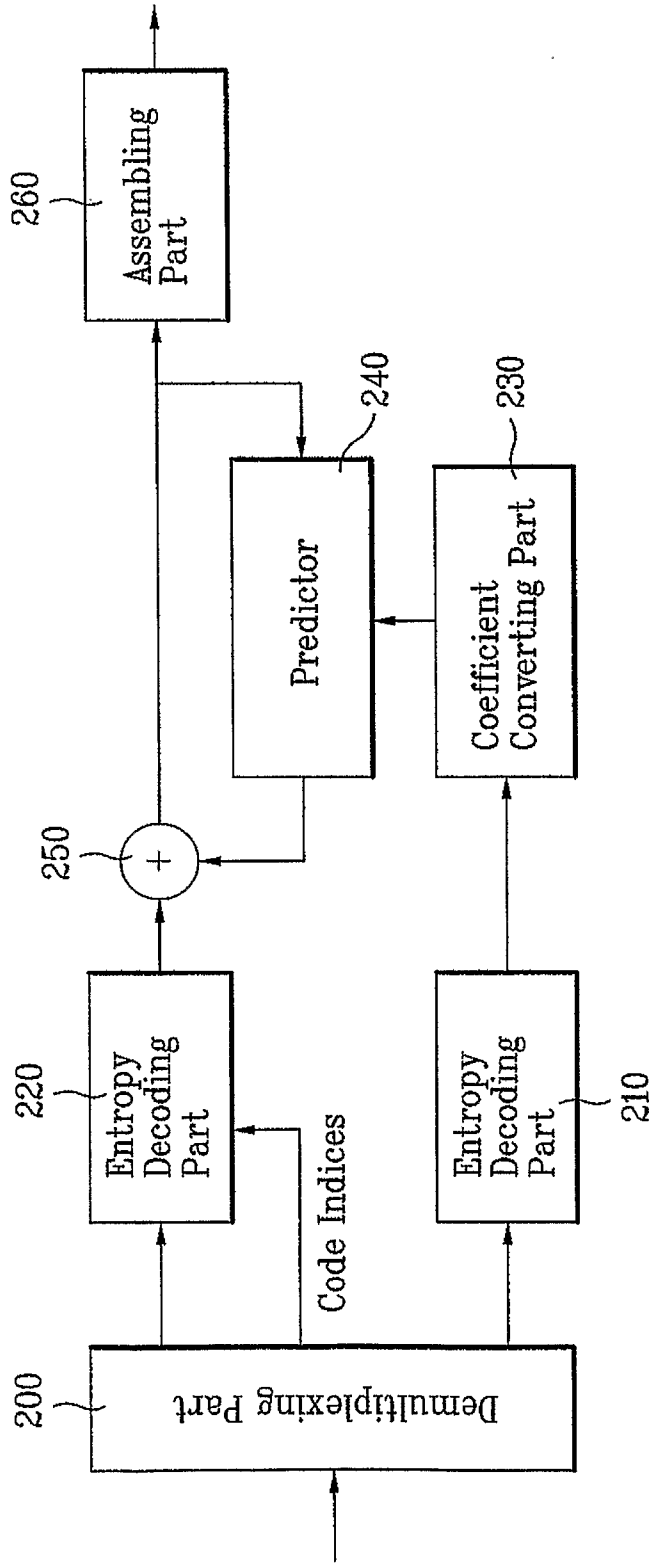
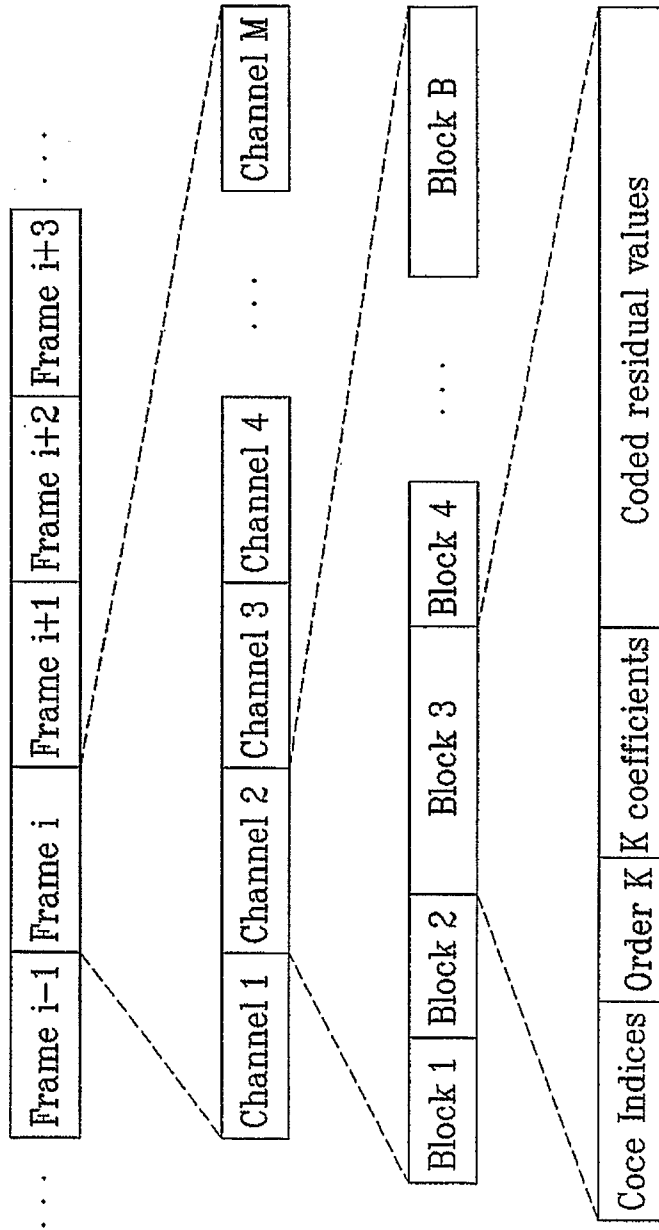

FIG. 3



4/6

FIG. 4

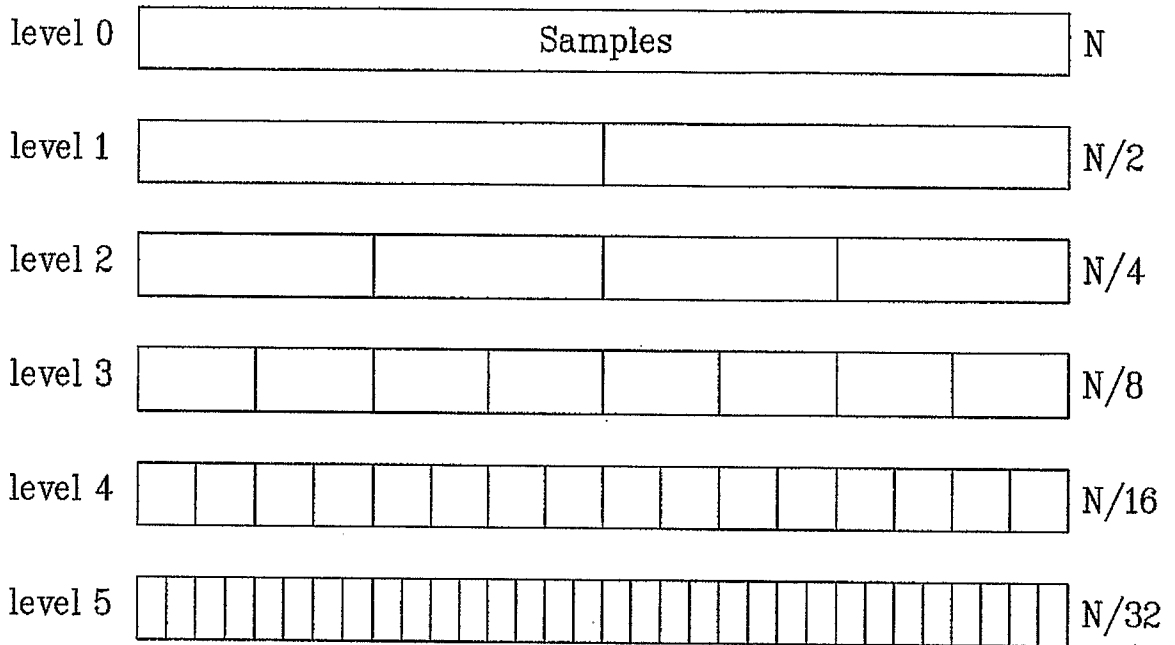

FIG. 5

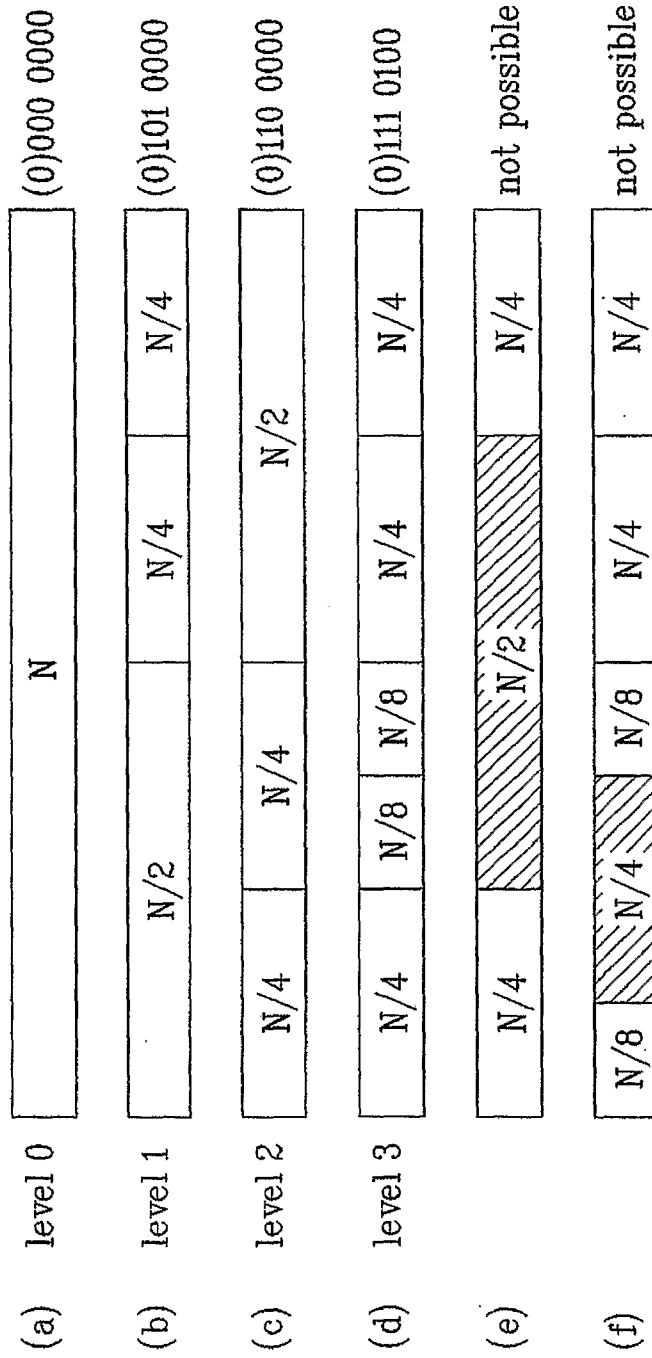

FIG. 6

