



(19) **United States**

(12) **Patent Application Publication** (10) **Pub. No.: US 2001/0004903 A1**

Ohmi et al.

(43) **Pub. Date: Jun. 28, 2001**

(54) **PARALLEL DIVIDED FLOW-TYPE FLUID SUPPLY APPARATUS, AND FLUID-SWITCHABLE PRESSURE-TYPE FLOW CONTROL METHOD AND FLUID-SWITCHABLE PRESSURE-TYPE FLOW CONTROL SYSTEM FOR THE SAME FLUID SUPPLY APPARATUS**

(57) **ABSTRACT**

(76) Inventors: **Tadahiro Ohmi**, Sendai-shi (JP); **Satoshi Kagatsume**, Nirasaki-shi (JP); **Kazuhiko Sugiyama**, Nirasaki-shi (JP); **Yukio Minami**, Osaka (JP); **Kouji Nishino**, Osaka (JP); **Ryousuke Dohi**, Osaka (JP); **Katsunori Yonehana**, Osaka (JP); **Nobukazu Ikeda**, Osaka (JP); **Michio Yamaji**, Osaka (JP); **Jun Hirose**, Nirasaki-shi (JP); **Kazuo Fukazawa**, Nirasaki-shi (JP); **Hiroshi Koizumi**, Nirasaki-shi (JP); **Hideki Nagaoka**, Nirasaki-shi (JP); **Akihiro Morimoto**, Osaka (JP); **Tomio Uno**, Osaka (JP); **Eiji Ideta**, Osaka (JP); **Atsushi Matsumoto**, Osaka (JP); **Toyomi Uenoyama**, Osaka (JP); **Takashi Hirose**, Osaka (JP)

A fluid supply apparatus with a plurality of flow lines branching out from one regulator for adjustment of pressure, the flow lines being arranged in parallel, wherein a measure is taken that the operation, that is, opening or closing of one flow passage will have no transient effect on the steady flow of the other flow passages. For this purpose, each flow passage is provided with a time delay-type mass flow controller MFC so that when one closed fluid passage is opened, the mass flow controller on that flow passage reaches a set flow rate Qs in a specific delay time Δt from the starting point.

Also provided are a method and an apparatus for the above in which a plurality of gas types can be controlled in flow rate with high precision by one pressure-type flow control system. To that end, a formula for calculating the flow rate of a gas is theoretically derived that flows with a pressure ratio not higher than the critical pressure ratio. From that formula, the flow factor is defined, so that the formula may be applied to a number of gas types using flow factors.

The method includes calculating the flow rate Qc of a gas passing through an orifice according to formula $Q_c = K P_1$ (K=constant) with a pressure P₁ on an upstream side of the orifice set at twice or more higher than pressure P₂ on a downstream side, wherein the flow factor FF for each kind of gas is calculated as follows:

$$FF = (k^{1/2} \gamma_s) \{2 / (\kappa + 1)\}^{1/2} \kappa / \{(\kappa + 1) R\}^{1/2}$$

and wherein, if the calculated flow rate of gas type A is Q_A, and, when gas type B is allowed to flow through the same orifice under the same pressure on the upstream side and at the same temperature on the upstream side, the flow rate Q_B is calculated as follows:

$$Q_B = (FF_B / FF_A) Q_A$$

where

γ_s=concentration of gas in standard state;

κ=ratio of specific heat of gas;

R=constant of gas;

K=proportional constant not depending on the type of gas;

FF_A=flow factor of gas type A; and

FF_B=flow factor of gas type B.

Correspondence Address:
GRIFFIN & SZIPL, PC
SUITE PH-1
2300 NINTH STREET, SOUTH
ARLINGTON, VA 22204 (US)

(21) Appl. No.: **09/734,640**

(22) Filed: **Dec. 12, 2000**

Related U.S. Application Data

(63) Continuation of application No. PCT/JP00/02160, filed on Apr. 3, 2000.

Foreign Application Priority Data

Apr. 16, 1999 (JP) 11-108689
May 10, 1999 (JP) 11-129109

Publication Classification

(51) **Int. Cl.⁷** **F17D 1/00**
(52) **U.S. Cl.** **137/613**

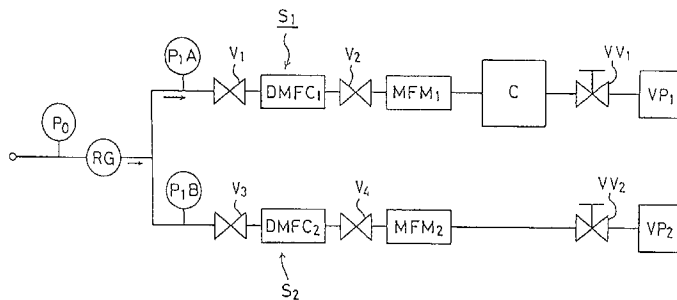

FIG. 1

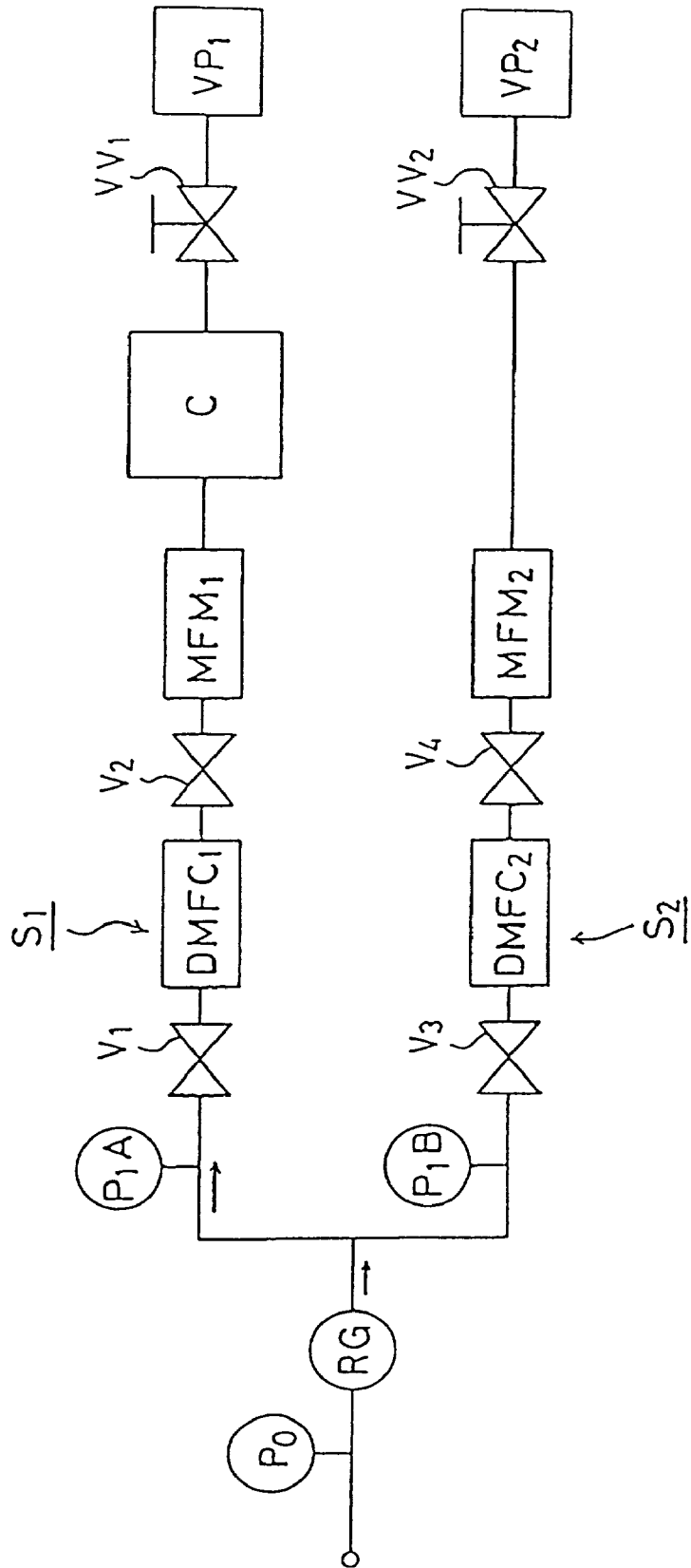

FIG. 2

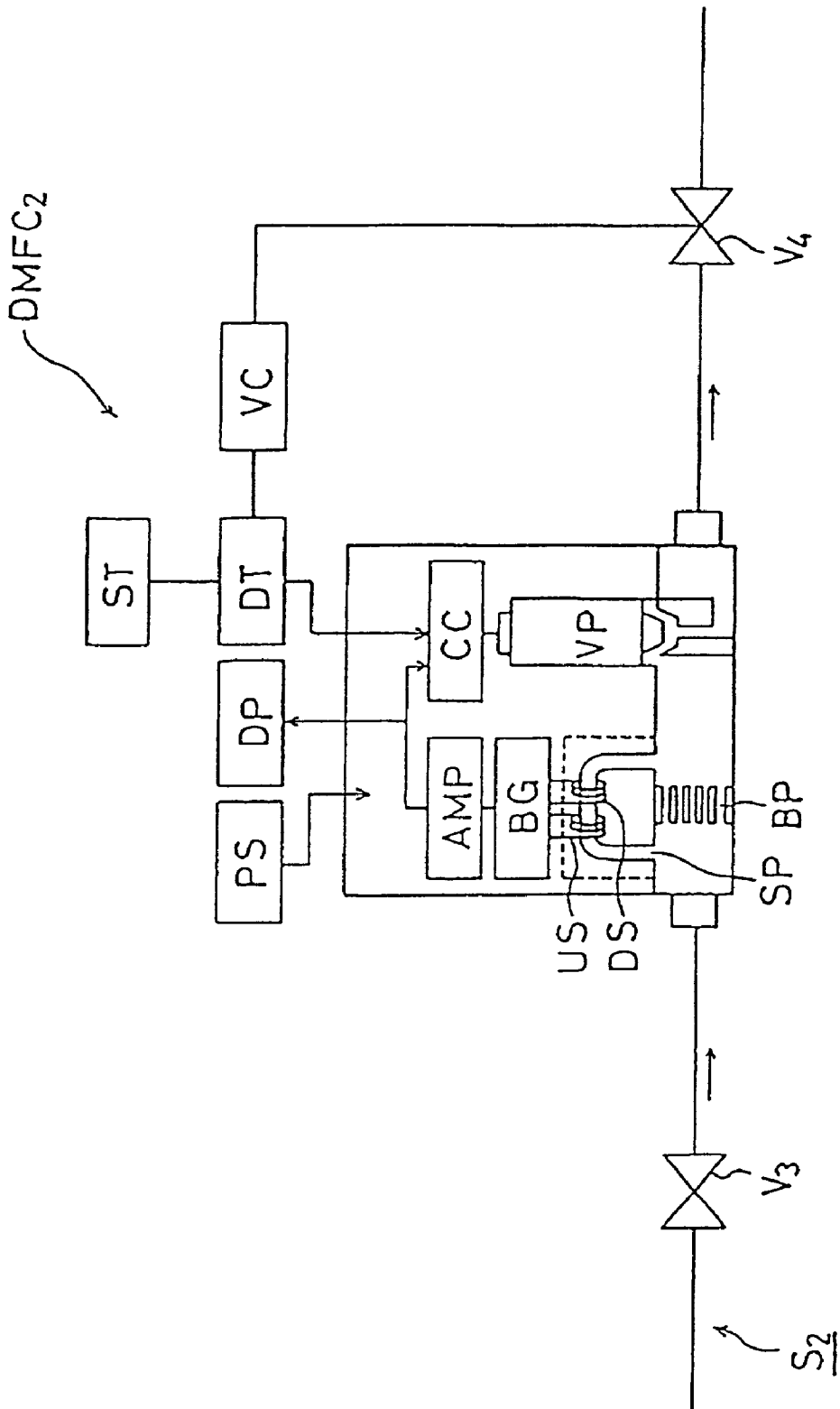

FIG. 3

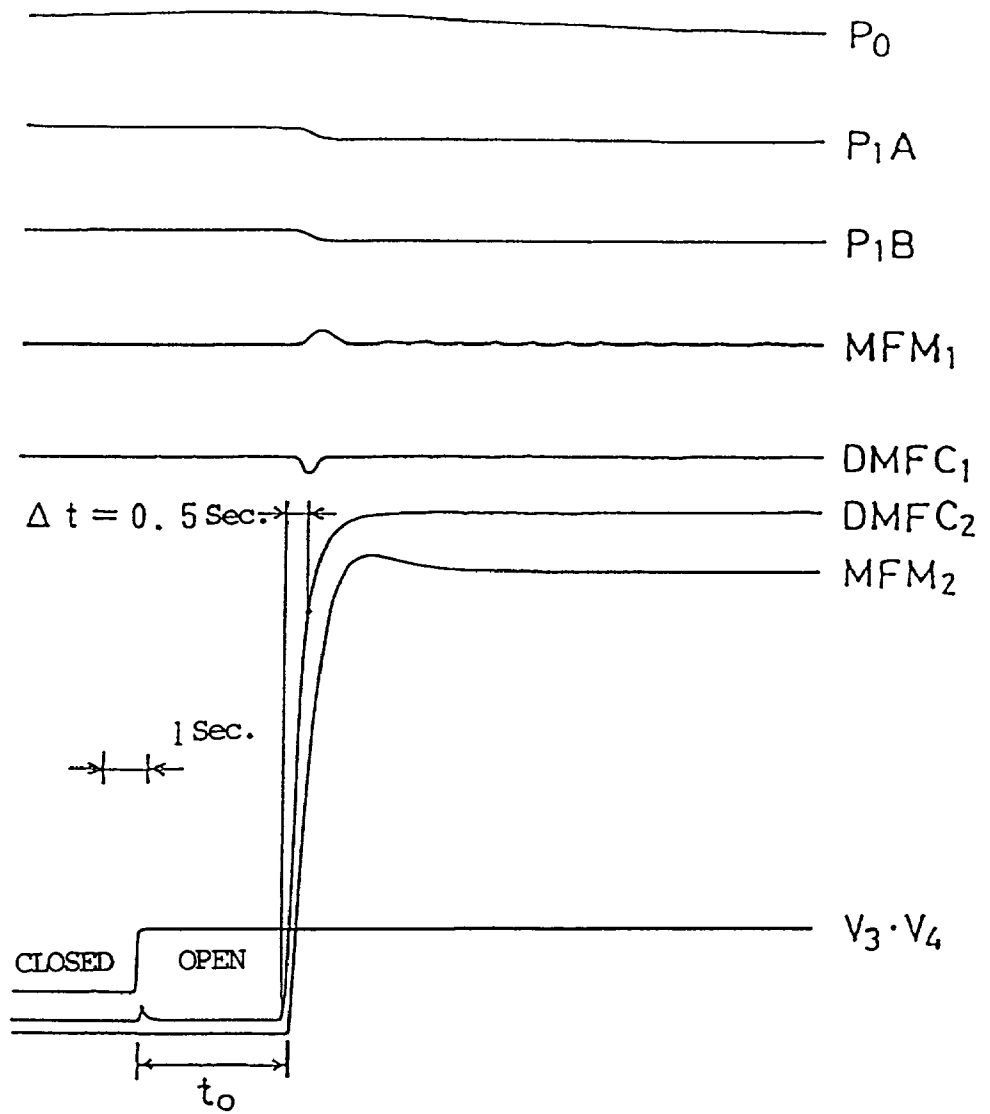

FIG. 4

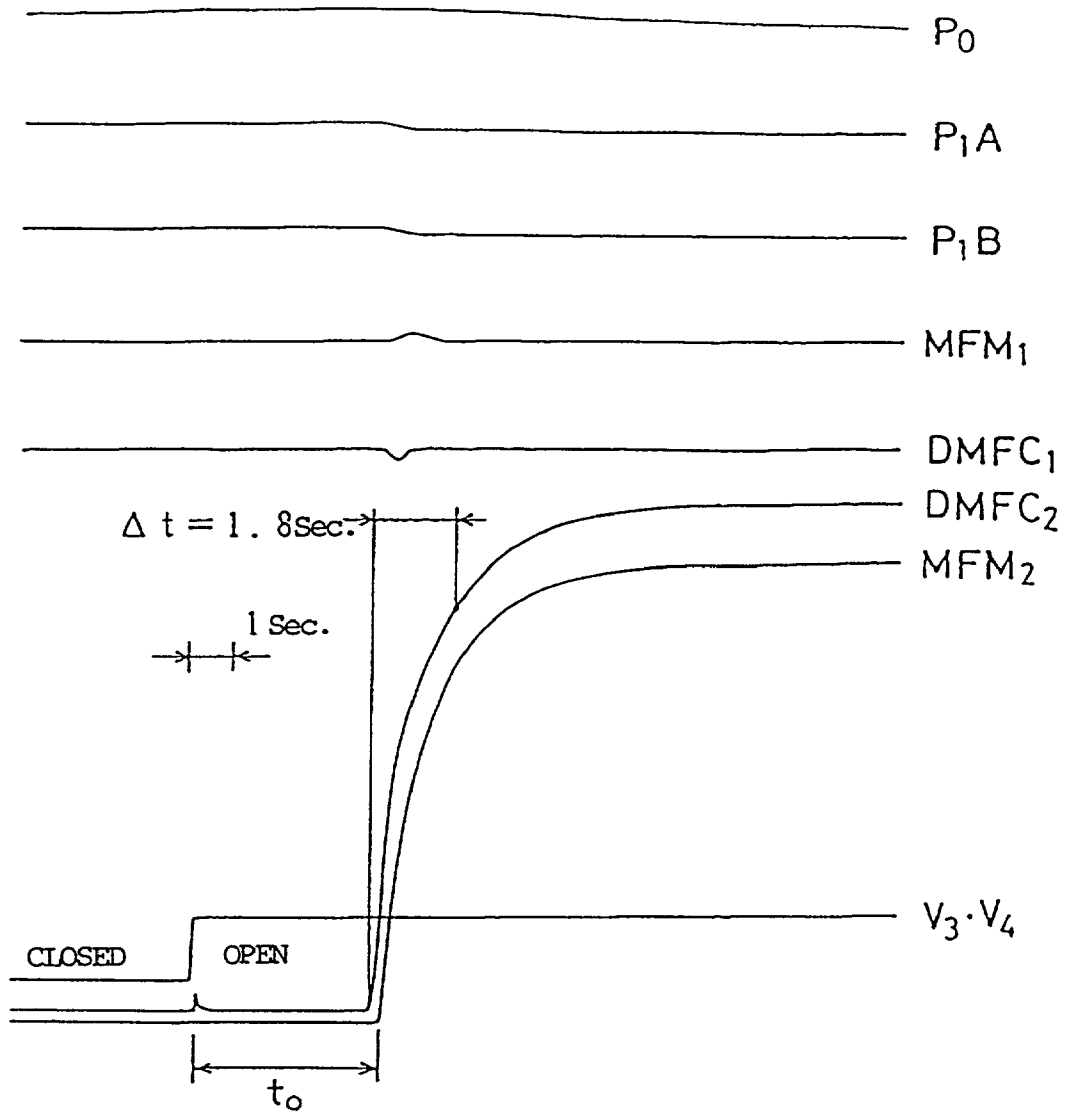

FIG. 5

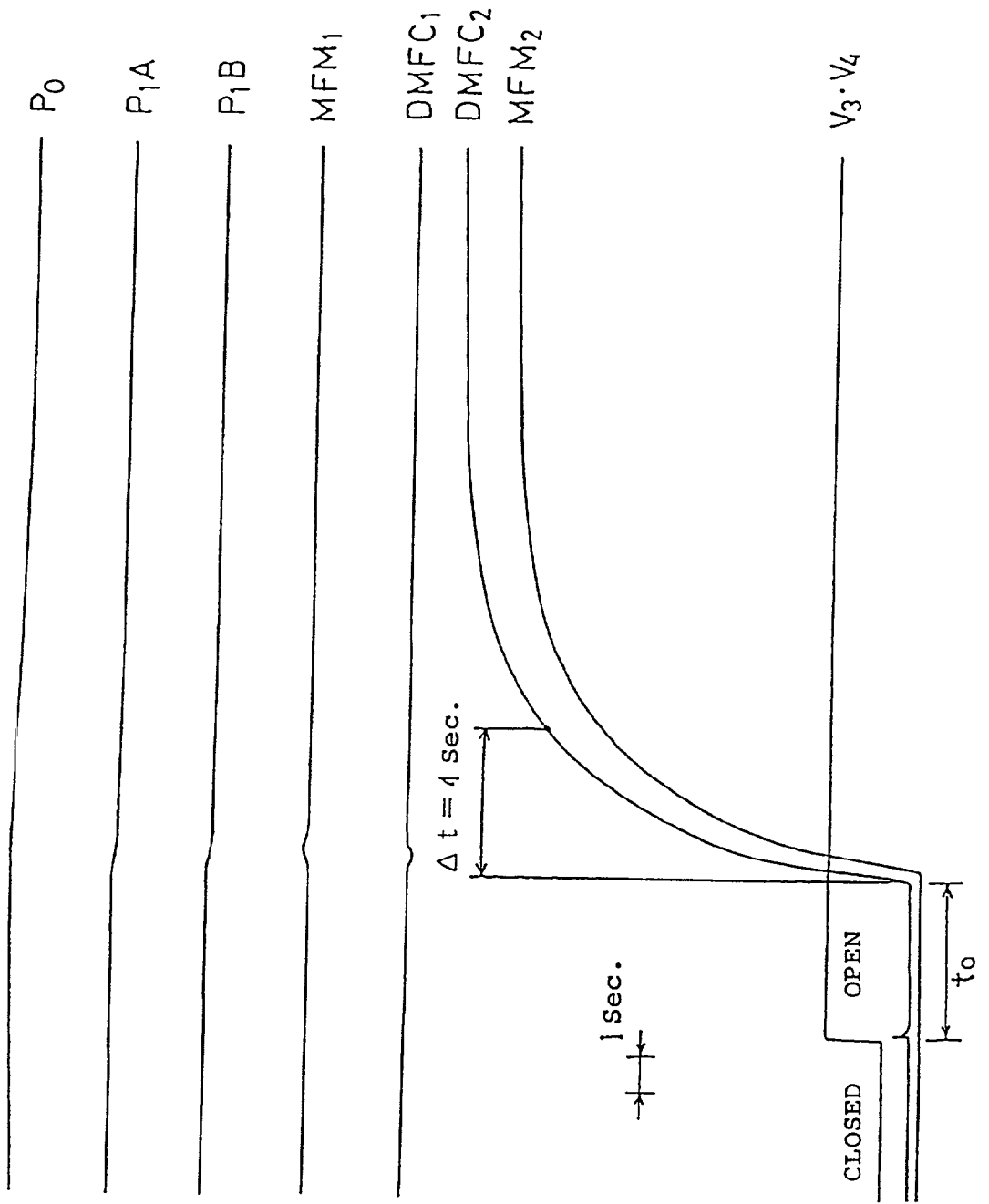

FIG. 6

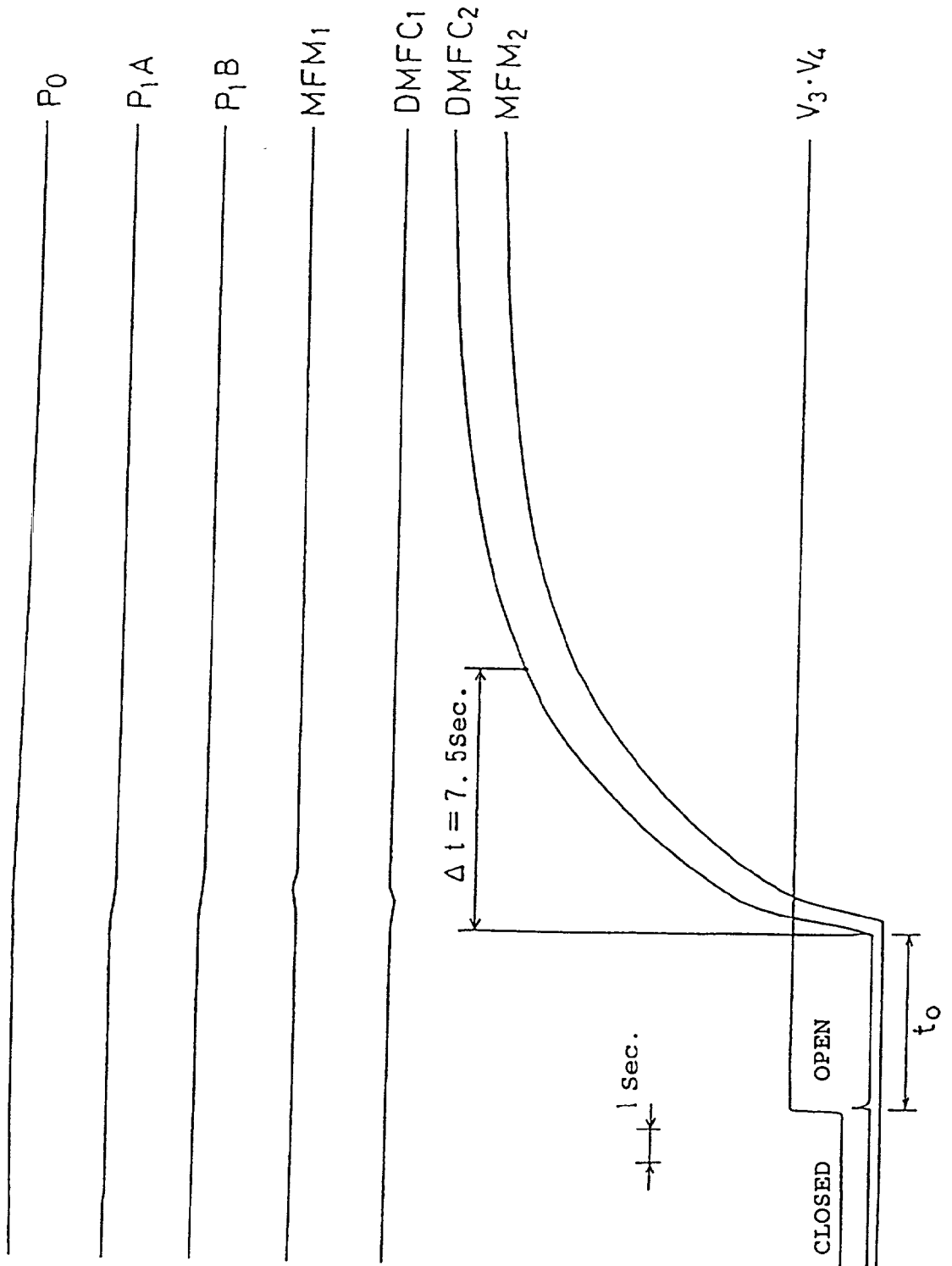

FIG. 7

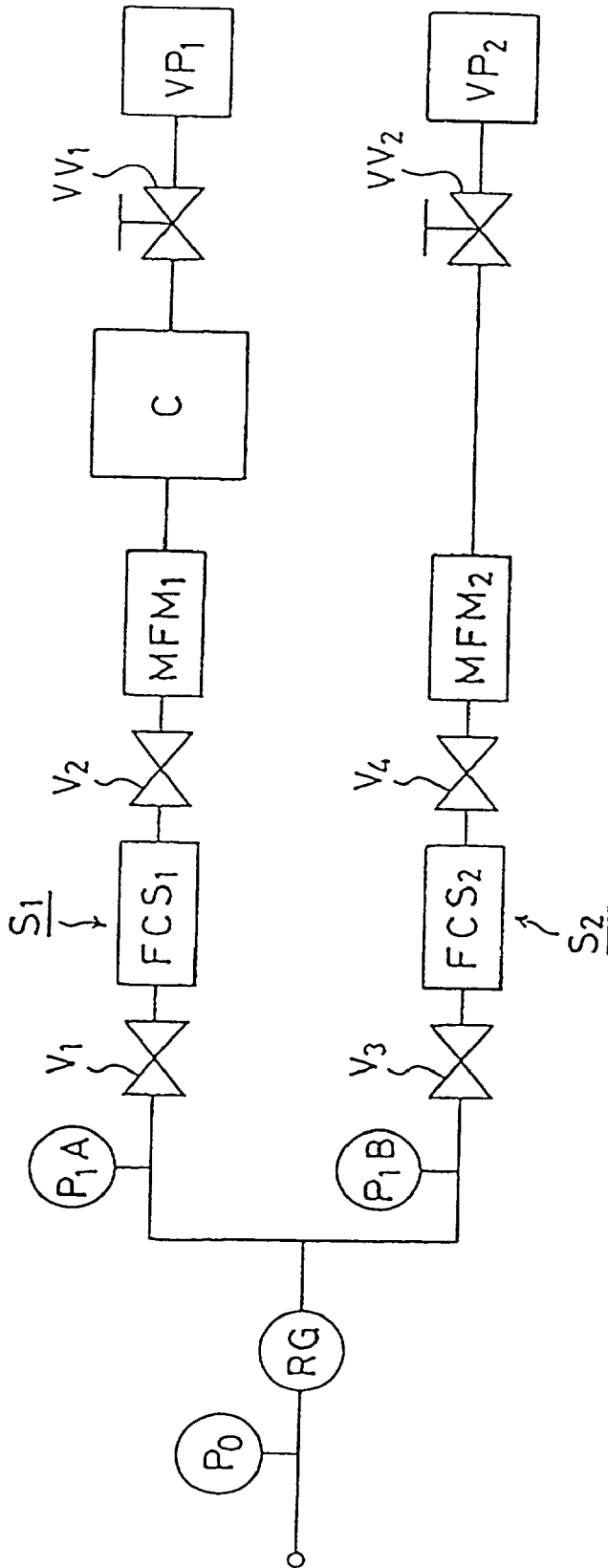

FIG. 8

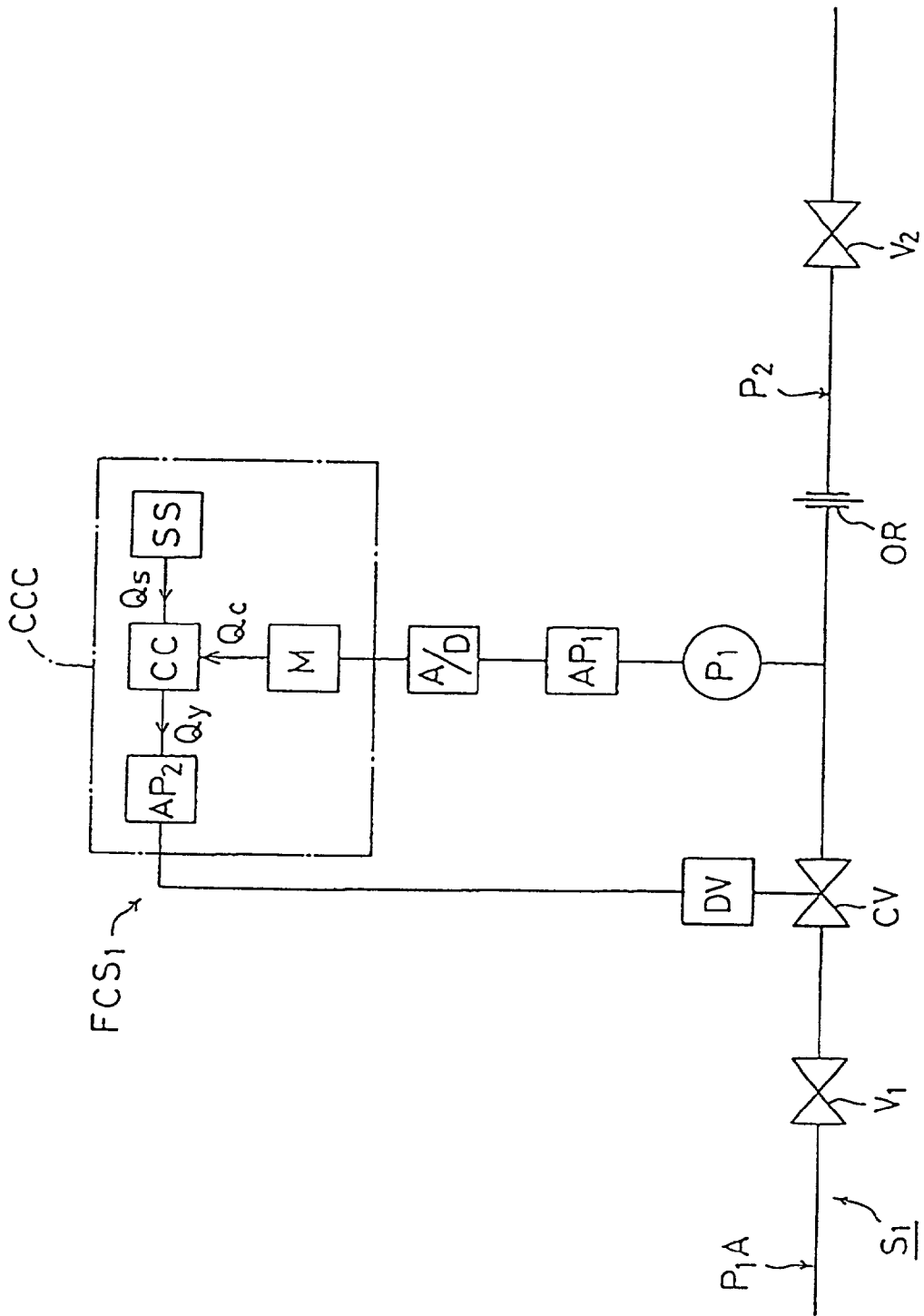

FIG. 9

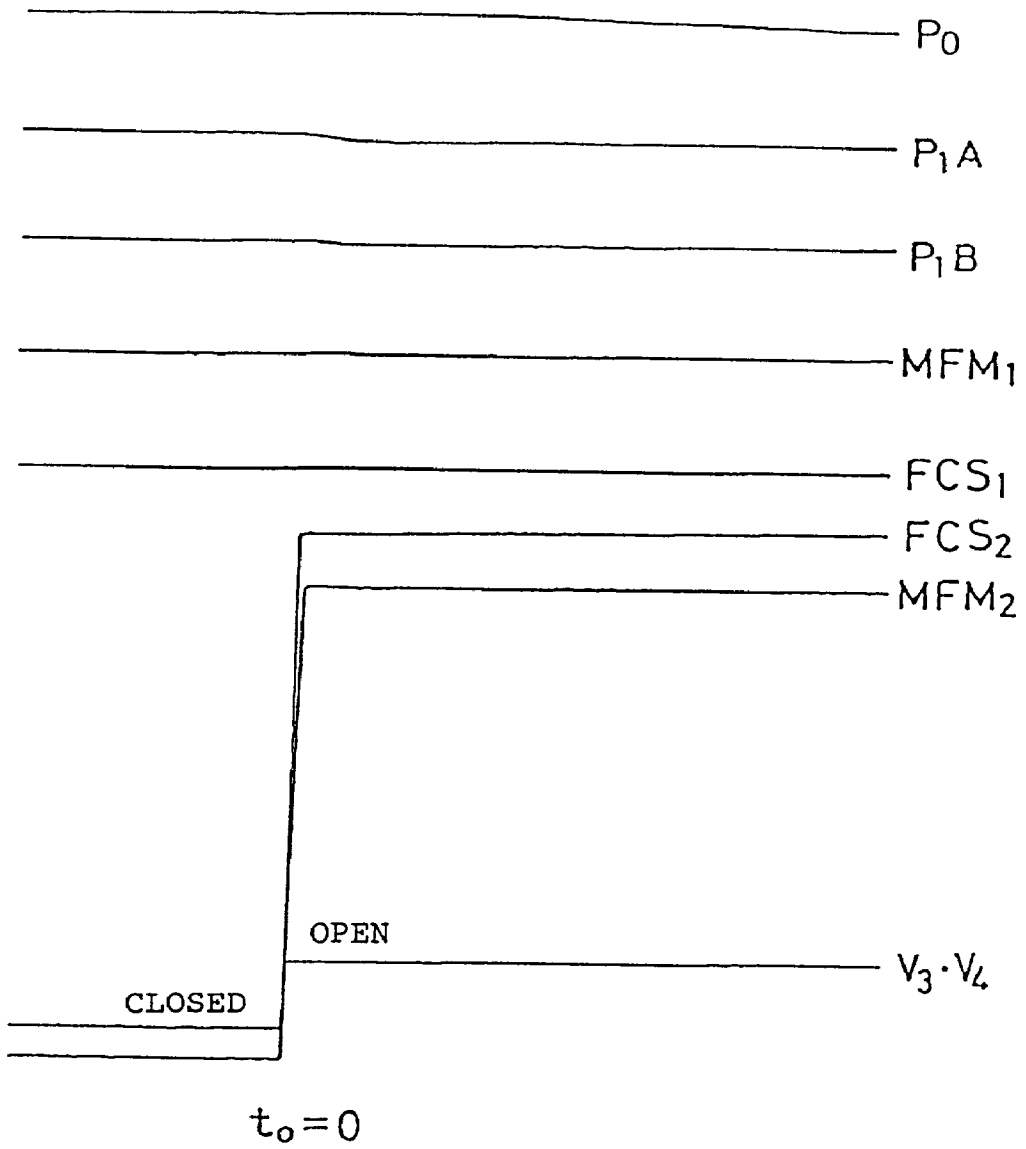

FIG. 10

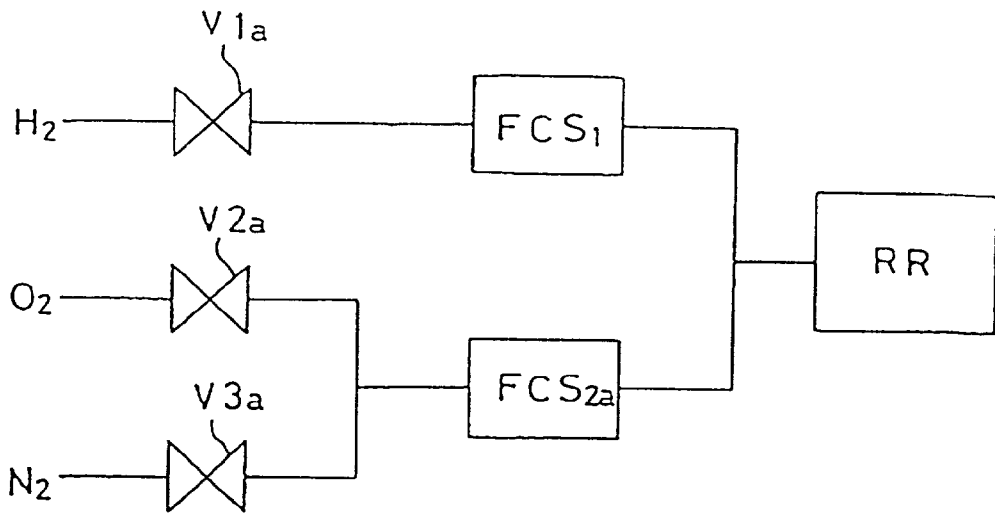

FIG. 11

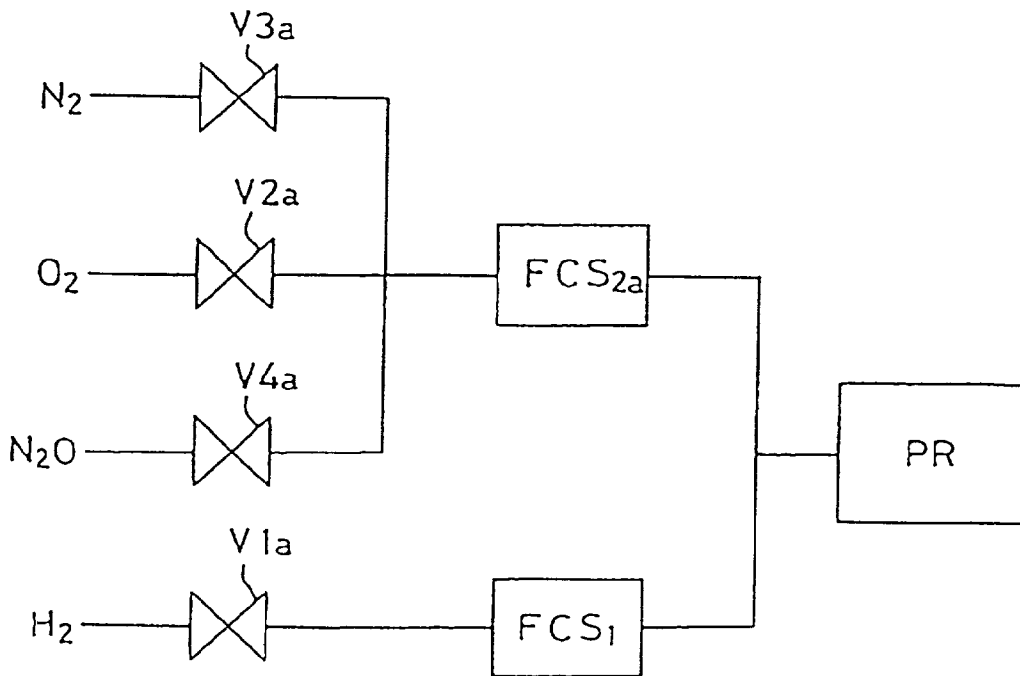

FIG. 12

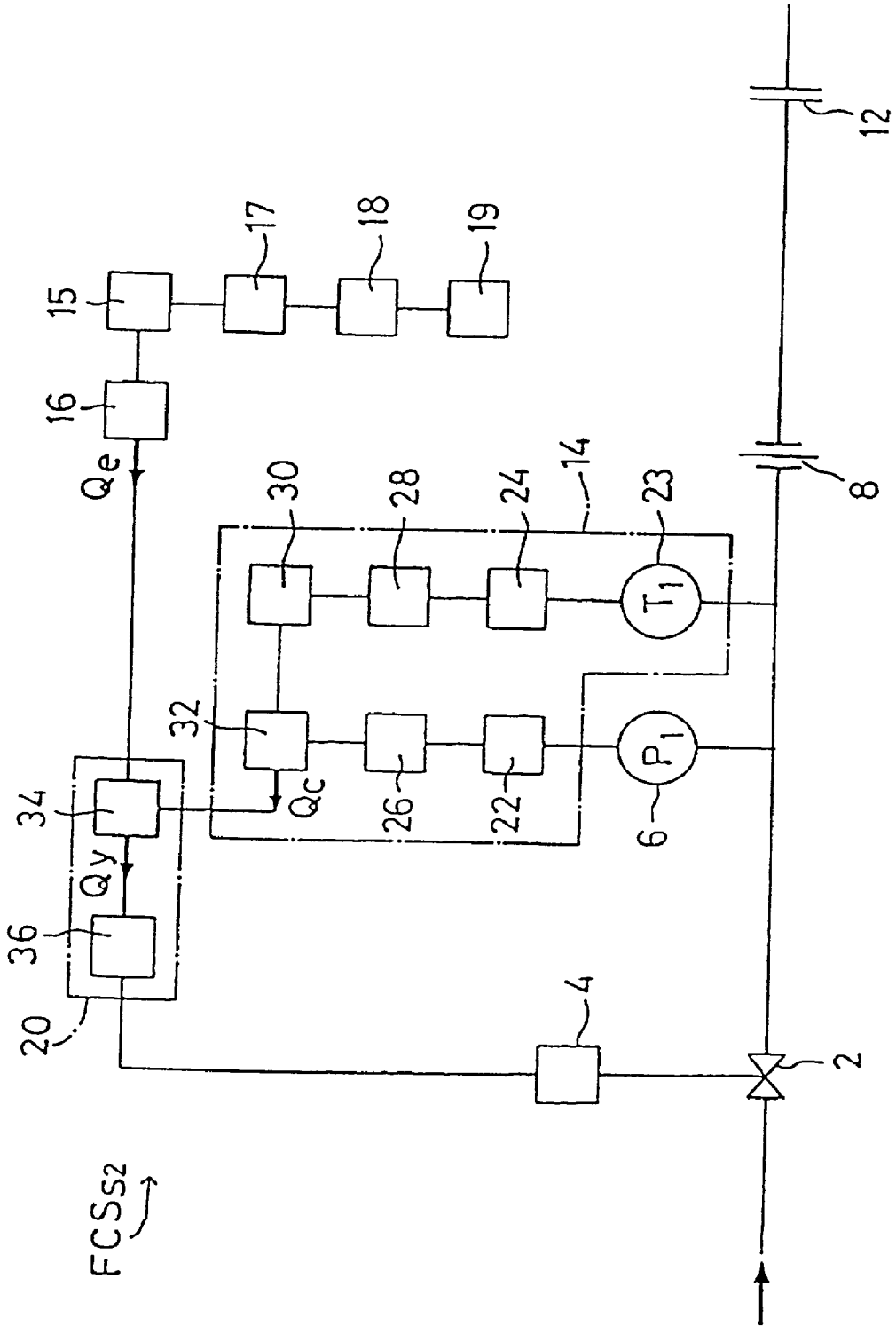

FIG. 13

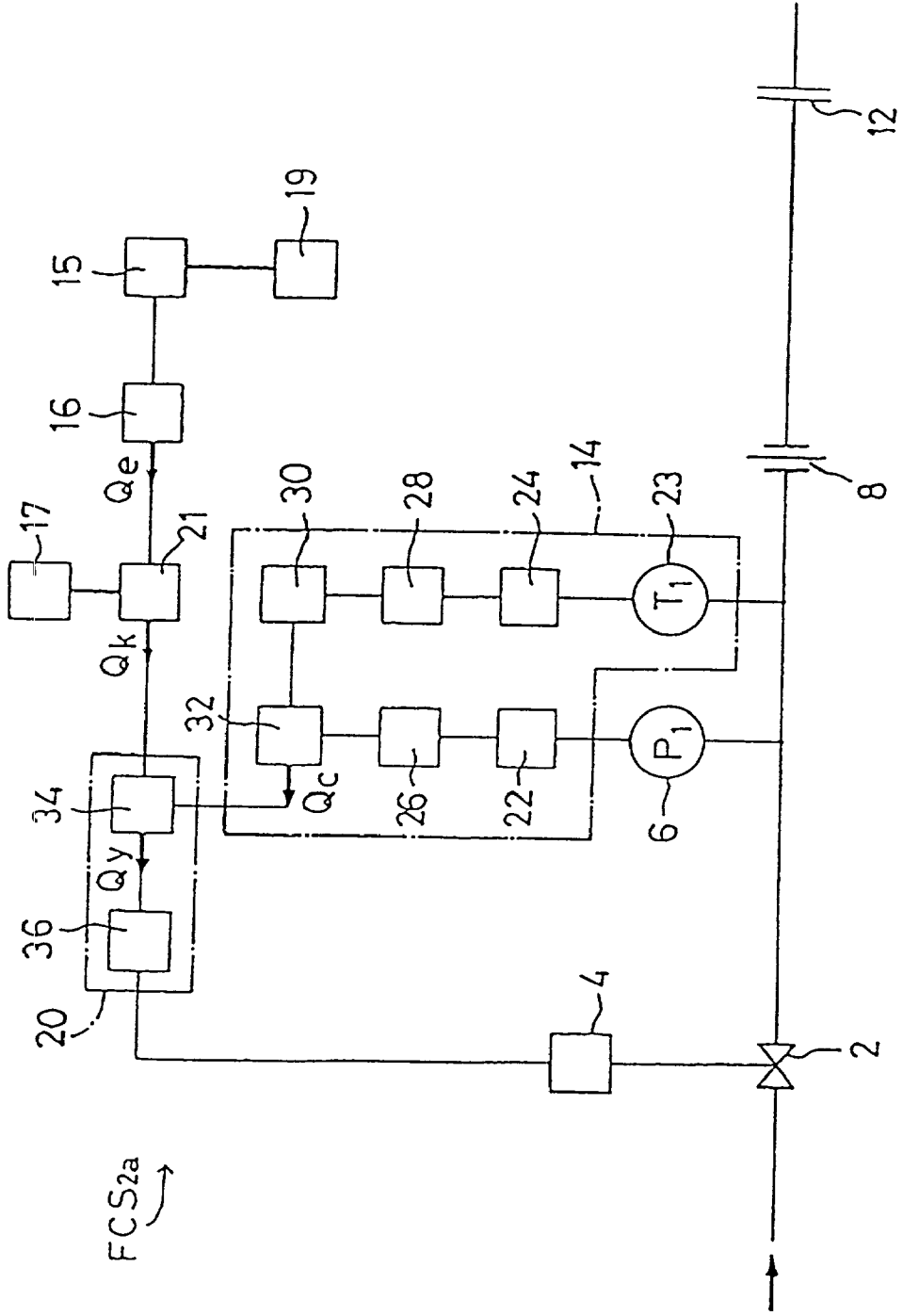

FIG. 14

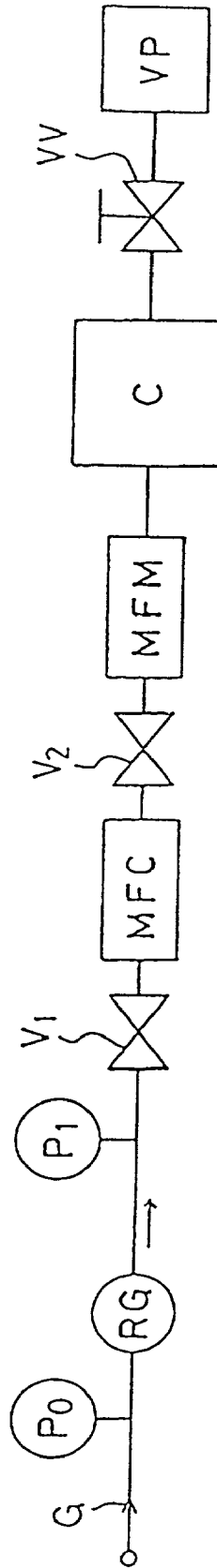

FIG. 15

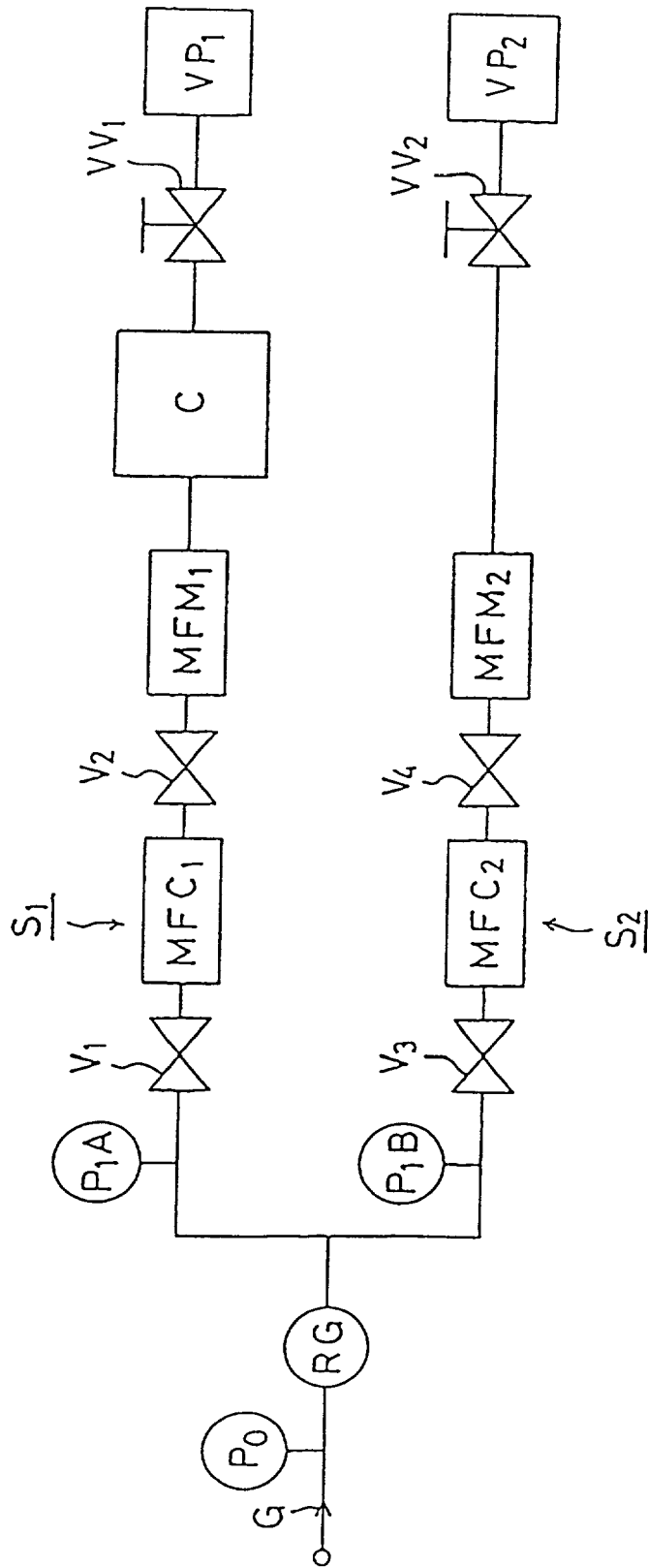

FIG. 16

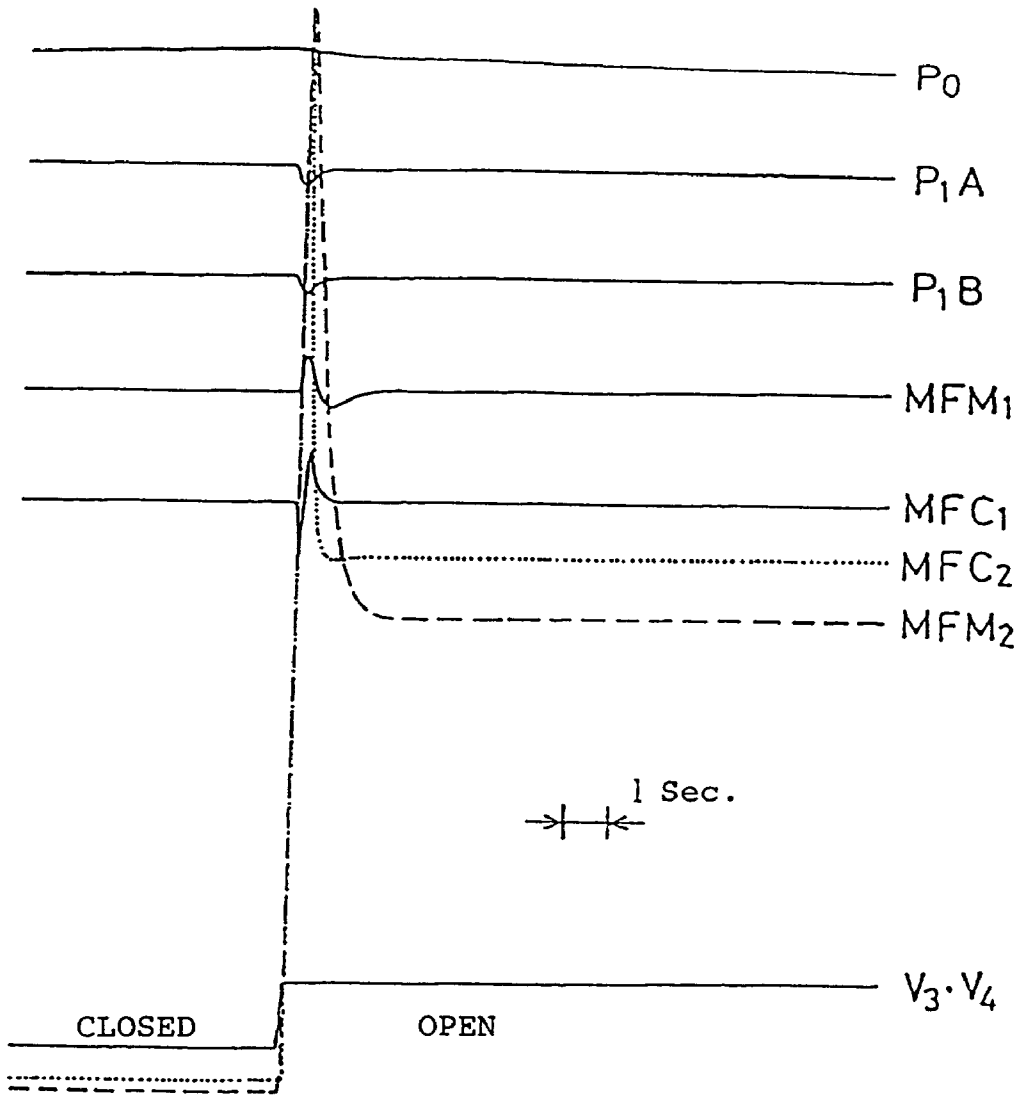

FIG. 17

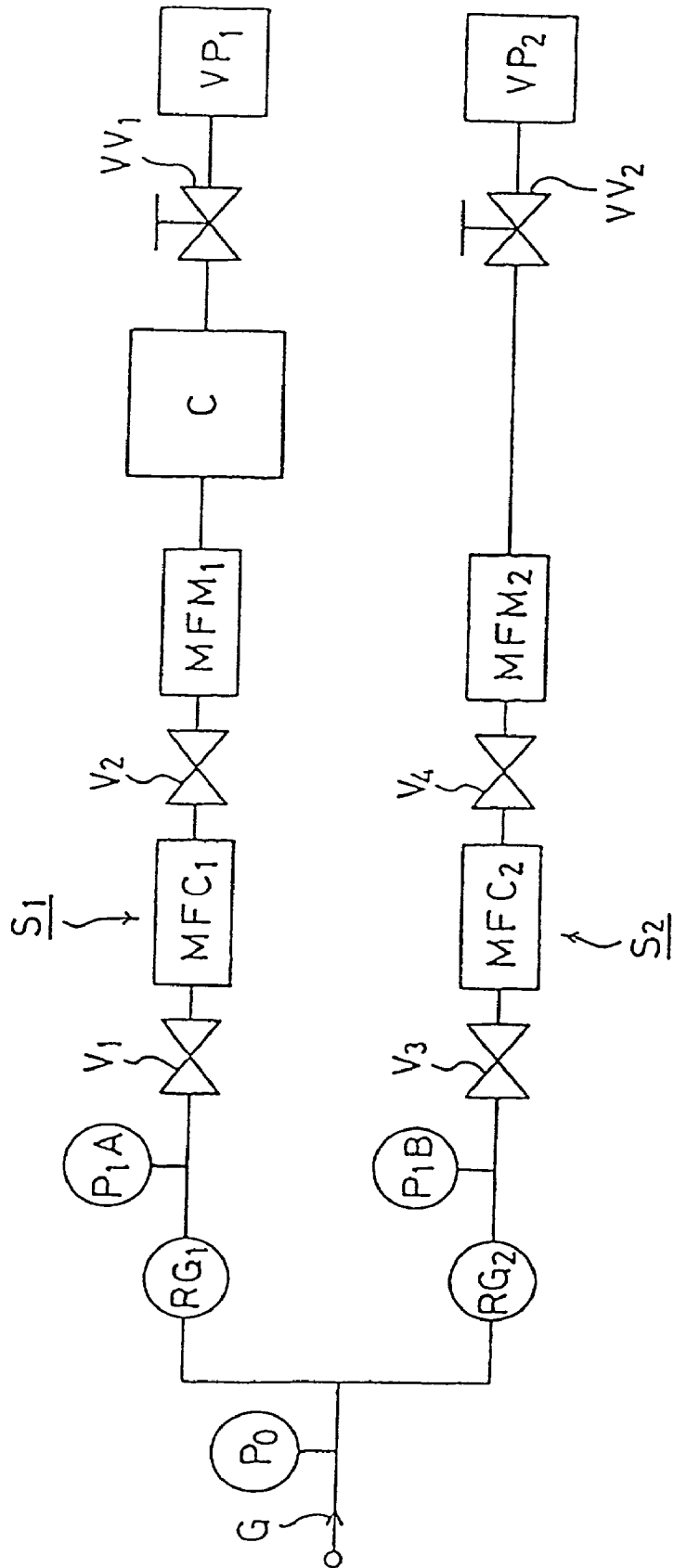
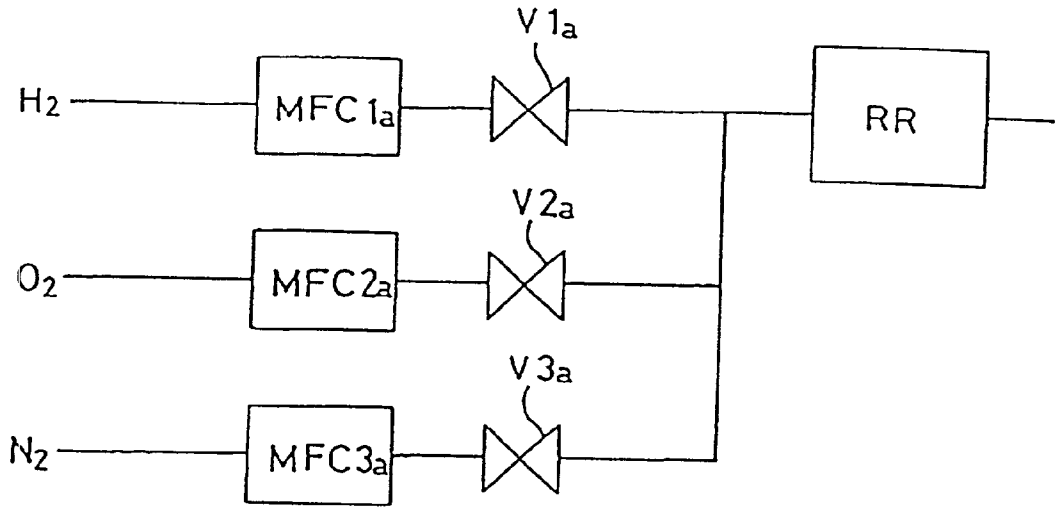

FIG. 18



PARALLEL DIVIDED FLOW-TYPE FLUID SUPPLY APPARATUS, AND FLUID-SWITCHABLE PRESSURE-TYPE FLOW CONTROL METHOD AND FLUID-SWITCHABLE PRESSURE-TYPE FLOW CONTROL SYSTEM FOR THE SAME FLUID SUPPLY APPARATUS

BACKGROUND OF THE INVENTION

[0001] 1. Field of the Invention

[0002] The present invention relates to an apparatus for supplying gases or the like for use in the production of semiconductors, chemicals, precision machine parts, etc. More specifically, this invention relates to a parallel divided flow type fluid supply apparatus so configured that when any one of a plurality of flow passages arranged in parallel is opened for fluid to flow, the effect of that operation on the flow rates in other flow passages is minimized.

[0003] The present invention also relates to a method of controlling the flow rates of various gases used in an apparatus for supplying gases or the like for use in the production of semiconductors, chemicals, precision machine parts, etc. More specifically, this invention relates to a fluid switchable pressure-type flow control method and a fluid switchable pressure-type flow control system (FCS) in which the flow of various gases can be regulated with high precision by one pressure-type flow control system on the basis of flow factors.

[0004] 2. Background Art

[0005] So-called mass flow controllers are now used in almost all fluid supply apparatuses for manufacturing facilities of semiconductors or chemicals.

[0006] FIG. 14 shows an example of the prior art single flow passage-type fluid supply apparatus in which such material gases G are adjusted by a regulator RG from primary pressure to secondary pressure before being sent into the flow passage. The primary pressure is usually a relatively higher pressure and detected by a pressure gauge P_0 . The secondary pressure is a relatively lower pressure under which the fluid is supplied to the downstream flow passage. The secondary pressure is measured by a pressure gauge P_1 .

[0007] A mass flow controller MFC is installed between valves V_1 and V_2 for control of the flow. Also provided is a mass flow meter MFM to measure the flow rate. The material gas G is used for a treatment reaction or the like in the reaction chamber C and then discharged by vacuum pump VP through a valve VV.

[0008] This single flow passage-type supply apparatus presents no problem with the treatment reaction remaining stable in the reaction chamber C as long as the material gas G is supplied in a normal state with no external disturbances or changes in flow rate.

[0009] But a problem is encountered with an arrangement in which material gas G is supplied through one regulator and branched off into two or more flow passages. FIG. 15 shows an arrangement in which the flow of the material gas G from one regulator RG branches off to two flow passages S_1 and S_2 . In practice, a reaction chamber (not shown) is also provided on flow passage S_2 and is so arranged that gas reaction may proceed into the two reaction chambers. The same elements or components as in FIG. 14 are indicated by the same reference characters with different suffixes given

for different flow passages. Those similar elements or components will not be described again.

[0010] An experiment was conducted to study what effect the opening of one closed flow passage would have on the flow of another opened flow passage. In the experiment, the material gas was supplied through flow passage S_1 with valve V_1 and valve V_2 opened and a specific reaction proceeding in the reaction chamber C, while the flow passage S_2 remained closed with valve V_3 and valve V_4 closed. Then, the valve V_3 and valve V_4 were opened to supply the gas into the flow passage S_2 at a specific set flow rate by quickly actuating mass flow controller MFC₂.

[0011] FIG. 16 shows the time charts of various signals. The instant the valve V_3 and valve V_4 were opened, MFC₂ and MFM₂ signals on flow passage S_2 overshot to a high peak and then fell to a constant level.

[0012] The overshooting or the transient state caused the signals of MFC₁ and MFM₁ on flow passage S_1 to change violently because of a change in pressures P_{1A} , P_{1B} .

[0013] This change in turn has an effect on the rate of reaction in the reaction chamber C. The external disturbance from flow passage S_2 hinders a steady reaction in the reaction chamber C on flow passage S_1 . In the process of manufacturing semiconductors, this problem could cause lattice defects in the semiconductor. In etching plasma, the process could be affected. In a chemical reaction, the over-supply or short supply of material gas G could cause finished products to change in concentration. This change could lead to unpredictable problems through "chaos phenomena." However, little transient effect is wrought on upstream pressure P_0 . This is because of the presence of the regulator RG.

[0014] To eliminate the external disturbance indicated in FIG. 16, it is desirable to install regulator RG₁ and regulator RG₂ on the two flow passages S_1 and S_2 as shown in FIG. 17. The regulator RG₂ could prevent the change in pressure from being felt on the upstream side when the flow passage S_2 is suddenly opened. The steady supply of the fluid in flow passage S_1 would not be affected. Conversely, the opening and closing of flow passage S_1 would have no effect on the side of flow passage S_2 .

[0015] In this connection, the regulator RG is a device to convert the high pressure fluid into low pressure fluid ready for supply to the downstream flow passage. However, the pressure changing device is itself expensive.

[0016] The number of regulators RG needed would increase with the number of flow passages. That would make the whole of the fluid supply arrangement complicated and large, sending up the costs.

[0017] In the fluid supply apparatuses shown in FIG. 14 and FIG. 15, only one kind of gas is supplied. In practice, however, a plurality of kinds of material gases G are led into the reaction chamber C, one by one or simultaneously, in semiconductor manufacturing facilities.

[0018] It is also noted that the mass flow controller is used at almost all semiconductor manufacturing facilities or chemical production plants where the flow rate is required to be controlled with high precision.

[0019] FIG. 18 shows an example of the high-purity moisture generating apparatus for use in semiconductor manufacturing facilities.

[0020] Three kinds of gases—H₂ gas, O₂ gas and N₂ gas—are led into a reactor RR through valves V_{1a}-V_{3a} with the flow rate controlled by the mass flow controllers MFC1a-MFC3a. The reactor RR is first purged with N₂ gas with valve V_{3a} opened and valves V_{1a}, V_{2a} closed. In the next step, the valve V_{3a} is closed and valves V_{1a}, V_{2a} are opened to feed H₂ gas and O₂ gas into the reactor RR. Here, H₂ gas and O₂ gas are reacted with platinum as catalyst to produce H₂O gas. The high-purity moisture thus produced is then supplied to downstream facilities (not shown).

[0021] The problem is that each mass flow controller has its linearity corrected for a specific kind of gas and a specific low rate range. That is, the mass flow controller cannot be used for other than the kind of gas for which the controller is adjusted.

[0022] That is why the mass flow controllers MFC1a to MFC3a are installed for H₂ gas, O₂ gas and N₂ gas, respectively, i.e., one mass flow controller for one kind of gas, as shown in FIG. 18. In a gas supply arrangement as shown in FIG. 18, furthermore, each of the mass flow controllers MFC1a to MFC3a is provided with a standby.

[0023] The mass flow controller is expensive and so are replacement parts. That increases the costs of gas supply facilities and the running costs.

[0024] Furthermore, if the mass flow controller is not replaced for a new kind of gas and, instead, the linearity is corrected every time a new gas is used, it takes long and it could happen that the operation of the manufacturing plant has to be temporarily suspended. To avoid that, it is necessary to have standby mass flow controllers for different kinds of gases ready in stock.

[0025] As set forth above, in case the flow passage from one regulator for regulation of pressure branches off into a plurality of parallel lines and each branch line is provided with a mass flow controller for regulation of the flow rate, then the opening of a branch line can cause a transient change to the other branch flow passages running in a steady state flow. This transient change in turn has an affect on the process in the reaction chamber off the branch line, causing a number of problems.

[0026] If each branch line is provided with one regulator to avoid such transient changes, meanwhile, that will make the fluid supply arrangement complicated and bulky, boosting the costs.

[0027] Furthermore, a large number of expensive standby mass flow controllers have to be stocked. That increases the costs of gas supply facilities and the running costs.

[0028] The present invention addresses these problems with the prior art.

SUMMARY OF THE INVENTION

[0029] Accordingly, it is an object of the present invention to provide a parallel divided flow type fluid supply apparatus which comprises a regulator RG to regulate the pressure of fluid, a plurality of flow passages S₁, S₂ into which a flow of fluid from the regulator RG is divided in the form of parallel lines and mass flow controllers DMFC₁, DMFC₂ for control of the flow rate, one controller installed on each flow passage, wherein the mass flow controller on a flow passage is so set that when the mass flow controller is actuated to open the passage for a steady flow state at a set flow rate, a delay time Δt is allowed for the flow rate to rise from the starting point to the set flow rate value Q_s.

[0030] It is another object of the present invention to provide a parallel divided flow type fluid supply apparatus wherein the delay time Δt is adjustable.

[0031] It is still another object of the present invention to provide a parallel divided flow type fluid supply apparatus which comprises a regulator RG to regulate the pressure of fluid, a plurality of flow passages S₁, S₂ into which a flow of fluid from the regulator RG is divided in the form of parallel lines and pressure-type flow control systems FCS₁, FCS₂, one system installed on each flow passage, the pressure-type flow control system comprising an orifice OR, a control valve CV installed upstream thereof, a pressure detector provided between the orifice and the control valve and a calculation control circuit CCC wherein with the pressure P₁ on the upstream side of the orifice set at twice or more higher than the pressure P₂ on the downstream side, the flow rate is calculated as Q_c=KP₁ (K=constant) from the pressure P₁ detected by the pressure detector and the difference between the calculated flow rate Q_c and the set flow rate Q_s is outputted as control signal Q_y to the drive DV of the control valve and wherein the flow rate downstream of the orifice is regulated by actuating the control valve.

[0032] It is a further object of the present invention to provide a fluid-switchable pressure-type flow control method by flow factor which comprises calculating the flow rate Q_c of the gas passing through the orifice according to the formula Q_c=KP₁ (K= constant) with the pressure P₁ on the upstream side of the orifice set at twice or more higher than the pressure P₂ on the downstream side, wherein the flow factor FF for each kind of gas is calculated as follows:

$$FF=(k/\gamma_s)\{2/(\kappa+1)\}^{1/(\kappa-1)}[\kappa/(\kappa+1)R]^{1/2}$$

[0033] wherein:

[0034] γ_s=concentration of gas in standard state

[0035] κ=ratio of specific heat of gas

[0036] R=constant of gas

[0037] k=proportional constant not depending on the type of gas

[0038] and wherein if the calculated flow rate of gas type A is Q_A, when gas type B is allowed to flow through the same orifice under the same pressure on the upstream side and at the same temperature on the upstream side, the flow rate Q_B is calculated as follows:

$$Q_B=(FF_B/FF_A)Q_A$$

[0039] wherein:

[0040] FF_A=flow factor of gas type A

[0041] FF_B=flow factor of gas type B

[0042] It is a still further object of the present invention to provide a flow factor-based fluid-switchable pressure-type flow control system which comprises a control valve, an orifice, a pressure detector to detect the upstream pressure therebetween and a flow rate setting circuit, wherein with the pressure P₁ on the upstream side held to be about twice or higher than the downstream pressure P₂, the flow rate Q_c of a specific gas type A can be calculated according to the formula Q_c=KP₁ (K=constant), wherein the control valve is controlled to open or close on the basis of the difference signal between the calculated flow rate Q_c and the set flow rate Q_s, characterized in that there is provided storage means for storing the flow factor ratio of gas type A to gas type B (FF_B/FF_A) which is calculated for each kind of gas as follows:

$$FF=(k/\gamma_s)\{2/(\kappa+1)\}^{1/(\kappa-1)}[\kappa/(\kappa+1)R]^{1/2}$$

[0043] Wherein:

[0044] γ_s =concentration of gas in standard state

[0045] κ =ratio of specific heat of gas

[0046] R =constant of gas

[0047] k =proportional constant not depending on the type of gas

[0048] and that there is provided calculation means in which in case the calculated flow rate of gas type A as reference is Q_A and when gas type B is allowed to flow through the same orifice under the same pressure on the upstream side and at the same temperature on the upstream side, the flow rate Q_B is calculated as follows:

$$Q_B=(FF_B/FF_A)Q_A.$$

[0049] It is still another object of the present invention to provide a parallel divided flow type fluid supply apparatus wherein the pressure-type flow control system to be installed in any of the flow passages is the flow factor-based fluid-switchable pressure-type flow control system described above.

[0050] After extensive study of the working characteristics of the mass flow controller in FIG. 15 and FIG. 16, the inventors found that if the mass flow controller is opened quickly up to the set flow rate level, a large quantity of material gas suddenly flows into flow passage S_2 . As a result, the pressure P_1A in flow passage S_1 drops transiently and causes the signal MFC_1 and signal MFM_1 to undergo a transient change.

[0051] To minimize the reflective, transient effect on flow passage S_1 of flow passage S_2 , it is important to let the gas flow into flow passage S_2 gradually. That is, after the valves V_3, V_4 are opened, mass flow controller MFC_2 should be so controlled that the flow rate is raised from "0" to the set flow rate level in a predetermined time.

[0052] That time is called delay time Δt . The longer the delay time Δt is, the less the transient effect becomes. If this delay time Δt can be freely changed, it is possible to cope with transient changes under various conditions.

[0053] The delay time Δt depends on the size of the set flow rate value Q_s , pipe diameter, type of fluids such as gas. It is desirable that the delay time Δt is determined empirically under various conditions.

[0054] The effect on flow passage S_1 of flow passage S_2 has been described. Conversely, the effect on flow passage S_2 of flow passage S_1 can be considered the same way. In case the number of flow passages are more than two, the transient effect can be treated the same way.

[0055] In case there are a plurality of flow passages and if all the mass flow controllers are to be subjected to time delay control, that can minimize the transient effect of the opening of any flow passage on other flow passages.

[0056] Thinking that the mass flow controller had unique characteristics that made it difficult to absorb the transient effect, the inventors also intensively sought some other method not using the mass flow controller.

[0057] As a result, the inventors concluded that the mass flow controller cannot absorb the transient effect very well because the controller measures the flow rate on the basis of the amount of heat transfer or heat carried by the fluid, and

if the change in flow rate is higher than the flow velocity, the control of the flow rate cannot follow the change in flow rate well.

[0058] Thinking that the problem could be solved by using a pressure-type flow control system that could quickly follow the change in flow rate, the inventors decided to adopt the pressure-type flow control system the inventors developed earlier and disclosed under Unexamined Japanese Patent Application No. 8-338546.

[0059] This pressure-type flow control system works on the following principle. When the pressure P_1 on the upstream side of the orifice is about twice as high as the pressure P_2 on the downstream side of the orifice, the velocity of the flow through the orifice reaches the sonic velocity, then the flow rate Q_c of the flow passing through the orifice is proportional to the pressure P_1 on the upstream side of the orifice. That is given in the equation $Q_c=KP_1$ (K : constant). In other words, if the pressure P_1 on the upstream side alone is known, the flow rate can be immediately worked out. While the mass flow controller determines the flow rate on the basis of heat transfer, the pressure-type flow control system is based on the theoretical properties of fluid. The pressure can thus be measured quickly.

[0060] If with a control valve installed on the upstream side of the orifice, the flow rate Q_c is worked out by equation $Q_c=KP_1$ and then the control valve is controlled to open or close to bring the difference from the set flow rate Q_s to zero, the calculated flow rate Q_c can be immediately adjusted to the set flow rate Q_s . That is made possible by the rapidity with which the pressure P_1 on the upstream side of the orifice can be measured. This arrangement can well absorb such changes as shown in FIG. 16.

[0061] While working toward development of a fluid supply apparatus using the pressure-type flow control system, furthermore, the inventors hit on a method that allows control of the flow rate without changing the basic setups for a plurality of kinds of gases by using a pressure-type flow control system in place of the traditional mass flow controller.

[0062] The pressure-type flow control system (FCS apparatus) the inventors developed earlier is to control the flow rate of the fluid with the pressure P_1 on the upstream side of the orifice held at about twice or more higher than the pressure P_2 on the downstream side. This FCS apparatus comprises an orifice, a control valve provided on the upstream side of the orifice, a pressure detector provided between the control valve and the orifice and a calculation control unit in which from the pressure P^1 detected by the pressure detector, the flow rate Q_c is calculated by equation $Q_c=KP_1$ (K : constant) and the difference between the set flow rate signal Q_s and the flow rate signal Q_c is outputted as control signal Q_y to the drive of the control valve, characterized in that the pressure P_1 on the upstream side of the orifice is regulated by opening or closing the control valve to control the flow rate on the downstream side of the orifice.

[0063] The most significant feature of the FCS apparatus is that the flow rate Q_c of the gas flowing through the orifice depends only on the pressure P_1 on the upstream side of the orifice and can be worked out by the equation $Q_c=KP_1$ (K : constant) for one orifice and one gas type.

[0064] In other words, if the orifice and gas type are selected and the proportional constant K is set, then the actual flow rate can be calculated with merely the measure-

ment of the P_1 on the upstream side of the orifice regardless of changes in the pressure P_2 on the downstream side of the orifice. It is the subject of the present invention to determine how the flow rate can be worked out in case the gas type is changed and the pressure found on the upstream side is P_1 under the above-mentioned set conditions.

[0065] To solve this problem, the meaning of constant K has to be clarified.

[0066] First, let it be assumed that a gas flows out through an orifice from the high pressure region to the low pressure region. The law of continuity, law of energy conservation and law of gas state (inviscidly of gas) are applied to the flow pipe. Also, it is presupposed that adiabatic change takes place when a gas flows out.

[0067] Further, let it be assumed that the flow velocity of gas flowing out of the orifice reaches the sonic velocity at that gas temperature. The conditions for the sonic velocity to be reached are that $P_1 \geq \text{about } 2P_2$. In other words, the pressure ratio of P_2/P_1 should not be higher than the critical pressure ratio of about $1/2$.

[0068] The flow rate Q at the orifice under those conditions is obtained as follows:

$$Q = SP_1/\gamma_s \{2/(\kappa+1)\}^{1/(\kappa-1)} \{2g/(RT_1) \cdot \kappa/(\kappa+1)\}^{1/2}$$

[0069] This flow rate Q can be solved as follows:

$$Q = FF \cdot SP_1(1/T_1)^{1/2}$$

[0070] $FF = (k/\gamma_s) \{2/(\kappa+1)\}^{1/(\kappa-1)} [k/(\kappa+1)R]^{1/2}$

$$k = (2 \times 9.81)^{1/2} = 4.429$$

[0071] The physical quantities including the units are as follows:

[0072] Q (m^3/sec) volumetric flow rate in standard state;

[0073] S (m^2)=sectional area of the orifice;

[0074] P_1 ($\text{kg}/\text{m}^2 \text{ abs}$)=absolute pressure on the upstream side;

[0075] T_1 (K)=gas temperature on the upstream side;

[0076] FF ($\text{m}^3\text{K}^{1/2}/\text{kg sec}$)=flow factor;

[0077] k : proportional constant;

[0078] γ_s (kg/m^3)=concentration of gas in standard state;

[0079] κ (dimensionless)=specific heat ratio of gas;

[0080] R (m/K)=gas constant.

[0081] Therefore, if it is assumed that the calculated flow rate $Q_c (=KP_1)$ is equal to the aforesaid flow rate Q , the constant K is given as $K = FF \cdot S/T_1^{1/2}$. It shows that the constant K depends on the gas type, gas temperature on the upstream side and sectional area of the orifice. From this, it is evident that the calculated flow rate Q_c depends on only flow factor FF under the same conditions, that is, the same pressure P_1 on the upstream side, the same temperature on the upstream side and the same sectional area of the orifice.

[0082] Flow factor FF , which depends on concentration γ_s in standard state, specific heat ratio κ and gas constant R , is a factor determined by the gas type only. That is, in case where the calculated flow rate of gas type A is Q_A , gas type B flows under the same pressure P_1 on the upstream side, at the same temperature T_1 on the upstream side through the same orifice sectional area, the calculated flow rate Q_B is

given as $Q_B = (FF_B/FF_A)Q_A$ where FF_A is the flow factor of gas type A and FF_B is flow factor of gas type B.

[0083] In other words, if the conditions are identical except for the gas type, the flow rate Q_B for another gas can be worked out merely by multiplying the flow rate Q_A by the flow factor ratio of FF_B/FF_A (FF ratio). Any gas type can be the reference gas type A. In the present invention, N_2 is used as a basis as is common practice. That is, the FF ratio is FF/FF_{N_2} . FF_{N_2} is the flow factor FF of N_2 gas. The physical properties and flow factors of different gases are shown in Table 1.

[0084] In calculation of FF ratios, the proportional constant K is eliminated by abbreviation. In calculating FF , therefore, the constant k may be any value. To give k as 1 ($k=1$) would simplify the calculation. Therefore, the proportional constant k in the respective claims is the higher in arbitrariness.

[0085] The authenticity of the aforesaid theory was confirmed in the following procedure. The first step is to flow N_2 gas to initialize the FCS apparatus and confirm that the linearity of $Q_c = KP_1$ is established under the conditions $P_1 \geq 2P_2$. The next step is to flow O_2 gas and set the P_1 on the upstream side of the orifice and at the temperature T_1 on the upstream side using the same orifice. O_2 gas flow rate Q_{O_2} is worked out using the equation $Q = FF \text{ ratio} \times Q_{N_2}$, that is, multiplying the N_2 gas flow rate Q_{N_2} by the FF ratio of $O_2 = 0.9349$. Meanwhile, the O_2 gas flow rate is compared with the value measured by build up method. It was confirmed that the error was within 1 percent. This shows that the aforesaid theory is correct.

TABLE 1

Physical properties and flow factors of different gases					
Gas type	γ_s (kg/m^3)	K (dimensionless)	R (m/K)	FF ($\text{m}^3\text{K}^{1/2}/\text{kg sec}$)	FF ratio (dimensionless)
N_2	1.25050	1.400	30.28	0.31167	1.0000
He	0.17850	1.660	211.80	0.87439	2.8055
Ar	1.78340	1.660	21.22	0.27649	0.8871
O_2	1.42895	1.397	26.49	0.29239	0.9349
CO_2	1.97680	1.301	19.27	0.24090	0.7730
H_2	0.08987	1.409	420.62	1.16615	3.7416
CO	1.25000	1.400	30.29	0.31174	1.0002
NO	1.34020	1.384	28.27	0.29978	0.9618
N_2O	1.98780	1.285	19.27	0.23853	0.7653
HCl	1.63910	1.400	23.25	0.27136	0.8707
NH_3	0.77130	1.312	40.79	0.38525	1.2361

As mentioned above, the flow rate Q of any gas can be calculated from the flow rate Q_{N_2} of N_2 gas by the equation $Q = FF \text{ ratio} \times Q_{N_2}$.

[0086] As mentioned above, the flow rate Q of any gas can be calculated from the flow rate Q_{N_2} of N_2 gas by the equation $Q = FF \text{ ratio} \times Q_{N_2}$.

[0087] While the equation $Q_N = KP_1$ is established, the P_1 on the upstream side is proportional to the opening degree of the control valve. With the N_2 gas flow rate for an opening degree of 100 percent as Q_{N100} , the N_2 gas flow rate Q_N for a certain opening degree is given as $Q_N = Q_{N100} \times (\text{opening degree}/100)$. Therefore, the flow rate Q of a gas type can be worked out as $Q = FF \text{ ratio} \times Q_{N100} \times (\text{opening degree}/100)$. The FF ratio in this case is FF/FF .

[0088] This formula for calculation of the flow rate is useful in finding the actual flow rate Q of gas from the opening degree of the control valve. But it is clear that the formula is identical with the aforesaid equation $Q = FF \text{ ratio} \times Q_N$.

[0089] Additional objects, features and advantages of the present invention will become apparent from the Detailed Description of Preferred Embodiments, which follows, when considered together with the attached figures.

BRIEF DESCRIPTION OF THE DRAWINGS

[0090] FIG. 1 is a schematic diagram of an embodiment of the parallel divided flow type fluid supply apparatus using the time delay-type mass flow controller according to one embodiment of the present invention.

[0091] FIG. 2 is a concrete schematic diagram of the time delay-type mass flow controller in FIG. 1.

[0092] FIG. 3 is a time chart of various signals in the apparatus of FIG. 1 with a delay time Δt of 0.5 second.

[0093] FIG. 4 is a time chart of various signals in the apparatus of FIG. 1 with a delay time Δt of 1 second.

[0094] FIG. 5 is a time chart of various signals in the apparatus of FIG. 1 with a delay time Δt of 4 seconds.

[0095] FIG. 6 is a time chart of various signals in the apparatus of FIG. 1 with a delay time Δt of 7.5 seconds.

[0096] FIG. 7 is a schematic diagram of an embodiment of the parallel divided flow type fluid supply apparatus according to another embodiment of the present invention using the pressure-type flow control systems.

[0097] FIG. 8 is a concrete schematic diagram of the pressure-type flow control system in FIG. 7.

[0098] FIG. 9 is a time chart of various signals in the apparatus of FIG. 7.

[0099] FIG. 10 is an arrangement diagram showing an application example of the fluid switchable pressure-type flow control system (FCS) in which three kinds of fluids are supplied through two FCS apparatuses at different flow rates.

[0100] FIG. 11 is an arrangement diagram showing another application example of the fluid switchable pressure-type flow control system (FCS) in which four kinds of fluids are supplied through two FCS apparatuses at different flow rates.

[0101] FIG. 12 is a block diagram of a fluid switchable pressure-type flow control system (FCS) according to a still further embodiment of the present invention.

[0102] FIG. 13 is a block diagram of another fluid switchable pressure-type flow control system (FCS) according to the embodiment of FIG. 12.

[0103] FIG. 14 is a schematic diagram of the prior art single flow passage fluid supply apparatus.

[0104] FIG. 15 is a schematic diagram of the prior art two flow passage fluid supply apparatus.

[0105] FIG. 16 is a time chart of various signals in the apparatus of FIG. 15.

[0106] FIG. 17 is another schematic diagram of the prior art two flow passage type fluid supply apparatus.

[0107] FIG. 18 is an arrangement diagram of a known high-purity moisture generating apparatus for semiconductor manufacturing facilities.

DESCRIPTION OF THE PREFERRED EMBODIMENTS

Example 1

Time Delay Type Mass Flow Controller

[0108] FIG. 1 is a schematic diagram of an embodiment of the parallel divided flow type fluid supply apparatus using the time delay-type mass flow controller according to the present invention. In FIG. 1, Po indicates a pressure gauge for measurement of supply pressure; P_{1A}, P_{1B}, pressure gauges for measurement of primary pressure; V₁ to V₄ valves; DMFC₁, DMFC₂, time delay-type mass flow controllers for control of flow rate; MFM₁, MFM₂, mass flow meters for measurement of flow rate; C, a reaction chamber; VV₁, VV₂, valves; VP₁, VP₂, vacuum pumps; and S₁, S₂, flow passages. The arrows indicate the direction of flow. Those components are given different suffixes on different flow passages. FIG. 1 is identical with FIG. 15 in arrangement.

[0109] FIG. 2 is a schematic diagram of the same time delay-type mass flow controller as in flow passage S₂. In the figure, VC indicates a valve detector to detect the close-to-open operation of valves V₃, V₄; ST, a flow rate setter; DT, time delay unit; PS, power source; DP, display; AMP, amplifier; BG, bridge circuit; CC, comparison circuit; and VP, valve unit. Further, BP designates bypass; SP, sensor; US, sensor on the upstream side; and DS, sensor on the downstream side.

[0110] The operation of the time delay type mass flow controller of FIG. 1 will now be explained.

[0111] Let it be assumed that the gas is flowing in flow passage S₁ on a steady basis with valve V₁ and valve V₂ kept open and with a stable gas reaction taking place in the reaction chamber C. Then, valve V₃ and valve V₄ are opened to allow the gas to flow into time delay-type mass flow controller DMFC₂.

[0112] Initially, the valve unit VP is fully closed. When the valve detector VC detects that valve V₃ and valve V₄ turn from close to open positions, the delay time unit DT begins to work after short time t₀. This short stop time t₀, which may be zero, is allowed as time t₀ settle the turbulence of the gas flow following the opening of valve V₃ and valve V₄.

[0113] The time delay unit DT allows delay time Δt . This is the time for the valve unit VP to gradually open to the flow rate Qs set by the flow rate setter ST. This delay time Δt is for the valve unit VP to open slowly so as to minimize the affect on other flow passages. Thus, the turbulence can be kept down by allowing short stop time t₀ and delay time Δt . The time t₀ settle the initial turbulence can be properly adjusted by making those times t₀ and Δt variable.

[0114] In the present example, valve V₃ and valve V₄ are opened simultaneously and the short stop time t₀ is set relatively long at 2 to 3 seconds. If the short stop time t₀ is set at zero or not longer than 0.5 seconds, the time difference in opening (or closing) time between valve V₃ and valve V₄ is a great factor in determining the affect on the other flow passage S₁.

[0115] In case the short stop time t₀ is very short, therefore, flow passage S₂ is opened this way. That is, valve V₄ is first opened and some one second later valve V₃ is opened. In closing the flow passage S₂, valve V₃ is first closed. Then, valve V₄ is closed some one second later. That is, it is

desirable to take care not to apply large fluid pressure on the mass flow controller DMFC₂ on the flow passage S₂ side.

[0116] The gas flow is divided into bypass section BP and sensor section SP. In the sensor section SP, the heat generated by the sensor US on the upstream side is detected by sensor DS on the downstream side, and the instantaneous flow rate Q is calculated by bridge circuit BG. After passing through amplifier AMP, the instantaneous flow rate Q is compared with the set flow rate Q_s in comparison circuit CC. The valve unit VP is opened in the aforesaid delay time Δt. When the set flow Q_s is reached, the valve unit VP is maintained in that position.

[0117] FIG. 3 to FIG. 6 show time charts of various signals with different delay times Δt. In those examples of measurements, delay time Δt is defined as the time required for the set flow rate to reach 80 percent, that is, the time it takes for the instantaneous flow rate Q to rise up to 80 percent of the set flow rate Q_s. Delay time Δt is defined in many other ways. It is understood that those other definitions of delay time fall within the scope of the present invention.

[0118] Different drawings show time charts with different delay times Δt: FIG. 3, delay time Δt=0.5 seconds; FIG. 4, delay time Δt=1.8 seconds; FIG. 5, delay time Δt=4 seconds; FIG. 6, delay time Δt=7.5 seconds. The short stop time t₀ can be set freely. In FIG. 3 to FIG. 6, it is set at 3 to 5 seconds. The short stop time t₀ may be still shorter.

[0119] Signals shown in FIG. 3 to FIG. 6 were measured under the same conditions as those in FIG. 12 except that the time delay type mass flow controllers DMFC₁, DMFC₂ were used instead of mass flow controllers MFC₁, MFC₂. A comparison of those time charts show that as the delay time Δt gets longer, the transient effects on the respective signals fall further. That demonstrates that the sharp drop in transient changes of signals P_{2A}, DMFC₁ and MFM₁ especially on flow passage S₁ well achieves the object of the present invention—the object to minimize the effect on flow passage S₁ of the opening of flow passage S₂.

Example 2

Pressure Type Flow Controller

[0120] FIG. 7 is a schematic diagram of an embodiment of the parallel divided flow type fluid supply apparatus according to a further embodiment of the present invention in which pressure-type flow control systems are used. FIG. 7 is identical with FIG. 1 in arrangement except that pressure-type flow control systems FCS₁, FCS₂ are used in place of time delay type mass flow controllers DMFC₁, DMFC₂. No description of like components will be repeated.

[0121] FIG. 8 is a schematic diagram of the pressure-type flow control system FCS₁ in flow passage S₁. The same is provided in flow passage S₂. Referring to FIG. 8, OR indicates orifice; P₁, pressure gauge on the upstream side of the orifice; AP₁, amplifier; A/D, A-D converter; M, temperature compensator; SS, flow rate setter; CC, comparison circuit; AP₂, amplifier; DV, drive; and CV, control valve. It is also understood that SS, CC, M and AP₂ as a whole are called calculation control circuit CCC.

[0122] The operation of the embodiment of FIG. 7 will now be explained. Let it be assumed that a closed flow passage S₂ is suddenly opened, and its pressure change causes a reverse flow in flow passage S₁. It has been theoretically proven that the instantaneous flow rate Q

passing through the orifice OR is given in the equation $Q = KP_1$ (K: constant) in the pressure-type flow control system FCS if the pressure P₁ on the upstream side of the orifice is held at about twice or more higher than the pressure P₂ on the upstream side of the orifice.

[0123] The upstream pressure measured by the pressure gauge P₁ on the upstream side of the orifice is put to amplifier AP₁ and converted by A-D converter. The converted value is then compensated for temperature by temperature compensator M into a calculated flow rate Q_c. This calculated Q_c is the aforesaid instantaneous flow rate Q. Therefore, the equation $Q_c = KP_1$ is established.

[0124] The set flow rate Q_s is inputted from the flow rate setter SS. And the difference from the aforesaid calculated flow rate Q_c is worked out as control signal Q_y ($Q_y = Q_s - Q_c$) by comparison circuit CC. The drive DV actuates control valve CV to bring the control signal Q_y to zero.

[0125] The pressure P₁ on the upstream side of the orifice can be measured instantaneously. Therefore, the operation of control valve CV can be controlled at an electronic speed. In other words, it is possible to speed up the operation up to the mechanical limit of the control valve.

[0126] Therefore, even if the flow of gas in flow passage S₂ causes a transient change to pressure P_{1A} in flow passage S₁, control valve CV responds at a high speed so that the flow rate through the orifice is quickly brought to the set flow rate Q_s. That is because the pressure-type flow rate control system corrects transient mutual changes in flow passages at a high speed and thus a steady flow is maintained.

[0127] FIG. 9 is a time chart of various signals in the embodiment shown in FIG. 7. If the pressure-type flow control system FCS₂ is actuated with valve V₃ and valve V₄ opened, FCS₂ signal and MFM₂ signal rise from zero to reach the steady value instantaneously. Yet, FCS₁ and MFM₁ signals in flow passage S₁ continue to stay at steady values, undergoing almost no changes.

[0128] In cases where the pressure-type flow control systems FCS₂, FCS₁ are used, no short stop time t₀ is needed after the aforesaid valve V₃ and valve V₄ are opened, that is, t₀=0.

[0129] As set forth above, the pressure-type flow control system can quickly correct the interfering inaction between the flow passages by opening and closing a flow passage and can maintain the supply of fluid in a steady state.

Example 3

Application Example of Fluid Switchable Pressure-type Flow Control System

[0130] FIG. 10 shows an application example of the fluid switchable pressure-type flow control system according to a still further embodiment of the present invention. This corresponds to the prior art using mass flow controllers shown in FIG. 18. The fluid switchable pressure-type flow control system is indicated by FCS_{2a}. That is, the flow rates of three kinds of gases—H₂ gas, O₂ gas and N₂ gas—are controlled by two pressure-type flow control systems FCS₁ and FCS_{2a}.

[0131] In FIG. 10, two pressure-type flow control systems FCS₁ and FCS_{2a} are required to supply H₂ and O₂ simultaneously to the reactor RR. But O₂ and N₂ do not have to be fed to the reactor RR at the same time, and the fluid

switchable pressure-type flow control system FCS_{2a} can be used for control of the flow rates of both O_2 and N_2 .

[0132] To generate moisture, the first step is to open valve V_{3a} with valves V_{1a} , V_{2a} closed to purge the reactor RR. Then, the valves V_{1a} , V_{2a} are opened and the valve V_{3a} is closed to feed H_2 gas and O_2 gas to the reactor RR. In the reactor RR, moisture, well balanced, is produced on a catalyst. This pure moisture is sent to downstream facilities.

[0133] It has been shown that H_2 gas and O_2 gas are sent into the reactor RR simultaneously. This is not always the case. In some cases, O_2 gas is first fed and then H_2 gas is supplied some time after that.

[0134] Needless to say, in case the flow rate of O_2 is controlled by a fluid switchable pressure-type flow control system FCS_{2a} , the aforesaid equation $Q=FF \text{ ratio} \times Q_N$ is applied.

Example 4

Another Application Example of Fluid Switchable Pressure-type Flow Control System

[0135] FIG. 11 shows another application example of the fluid switchable pressure-type flow control system FCS_{2a} —an example where the fluid switchable pressure-type flow control system FCS_{2a} is applied to the so-called single chamber multiple process in semiconductor manufacturing facilities.

[0136] If Si is going to be nitrided immediately after oxidation in FIG. 11, for example, the system is first purged with N_2 gas and then H_2 gas and O_2 gas are supplied to the reactor RR to oxidize Si. Then, N_2O gas is supplied to nitride the Si oxide film. Finally, N_2 gas is supplied to purge the system.

[0137] That is why the application example of the flow control system in FIG. 11 uses one pressure-type flow control system FCS_1 and one fluid switchable pressure-type flow control system FCS_{2a} —a total of two units. But if this fluid supply apparatus is formed of the prior art mass flow controllers alone, it will be necessary to install four units. That boosts the equipment costs greatly even if the expenses for standby units are excluded.

Example 5

An Example of Fluid Switchable Pressure-type Flow Control System

[0138] FIG. 12 is a block diagram of an embodiment of the fluid switchable pressure-type flow control system according to the present invention.

[0139] This fluid switchable pressure-type flow control system FCS_{2a} comprises a control valve 2, its drive unit 4, a pressure detector 6, an orifice 8, a joint for taking gas 12, a flow rate calculation circuit 14, a gas type selection circuit 15, a flow rate setting circuit 16, an FF ratio storage means 17, a flow rate calculator 18, a flow rate display means 19 and a calculation control circuit 20.

[0140] The circuit 14 for calculation of flow rate is formed of a temperature detector 23, amplification circuits 22, 24, A-D converters 26, 28, a temperature compensation circuit 30 and a calculation circuit 32. The calculation control circuit 20 is made up of a comparison circuit 34 and an amplification circuit 36.

[0141] The aforesaid control valve 2 is equipped with the so-called direct touch-type metal diaphragm. Drive unit 4 is a piezoelectric element-type drive unit. Other types of drive units may also be used. They include magnetostrictive type or solenoid type, motor-driven, pneumatic type and thermal expansion type units.

[0142] The aforesaid pressure detector 6 is a semi-conductor strain type pressure sensor. Other types may also be used. They include the metal foil strain type, capacitance type, magnetic resistance type sensors.

[0143] The aforesaid temperature detector 23 is a thermocouple type temperature sensor. Other known temperature sensors such as resistance bulb type may be used instead.

[0144] The aforesaid orifice 8 is an orifice made of a plate-formed metal sheet gasket provided with a bore by cutting. In place of that, other orifices may be used. They include orifices with a bore formed in metal film by etching or electric discharge machining.

[0145] The gas type selection circuit 15 is a circuit to select a gas type among H_2 gas, O_2 gas and N_2 gas. The flow rate setting circuit 16 its flow rate setting signal Q_e to the calculation control circuit 20.

[0146] The FF ratio storage means 17 is a memory where the FF ratios to N_2 gas are stored. With N_2 gas as 1, the ratio for O_2 is given as FF_O/FF_N and H_2 gas as FF_H/FF_N . FF_N , FF_O and FF_H are flow factors of N_2 , O_2 and H_2 respectively. Calculation and storing of FF ratios may be arranged this way, for example. There is provided an FF calculator (not shown) which reads data from the FF storage means and works out FF ratios. The calculated FF ratios are stored in the FF ratio storage means 17.

[0147] The flow rate calculator 18 works out the flow rate Q of the flowing gas type by $Q=FF \text{ ratio} \times Q_N$ (Q_N : corresponding N_2 gas flow rate) using the FF ratio. The value is then shown on the flow rate display means 19.

[0148] The operation of this fluid switchable pressure-type flow control system FCS_{2a} will now be explained.

[0149] First, let it be assumed that the whole apparatus is initialized with N_2 gas as a reference or basis.

[0150] The gas type selection circuit 15 N_2 gas, and the flow rate setting circuit 16 specifies flow rate setting signal Q_e . Control valve 2 is opened, and the gas pressure P_1 on the upstream side of the orifice is detected by pressure detector 6. The data is sent through the amplifier 22 and the A-D converter 26 to produce digitized signals. The digitized signals are then outputted into the calculation circuit 32.

[0151] Similarly, the gas temperature T_1 on the upstream side of the orifice is detected by temperature detector 23 and sent to the amplifier 24 and the A-D converter 28. Thus, data is digitized and the digitized temperature signals are inputted in the temperature compensation circuit 30.

[0152] In the calculation circuit 32, the flow rate Q is worked out by the equation $Q=KP_1$ using the pressure signal P_1 . At the same time, the aforesaid flow rate Q is temperature-compensated with the compensation signals from the temperature compensation circuit 30. The calculated flow rate Q_c is then outputted to the comparison circuit 34. The constant K in the equation is set for N_2 gas as mentioned earlier.

[0153] The difference signal Q_d between the calculated flow rate Q_c and the flow rate setting signal Q_e is outputted

from the comparison circuit **34** through the amplification circuit **36**. Then the drive unit **4** actuates and operates the control valve **2** so that the difference signal Q_y is reduced zero. A series of those steps sends out N_2 gas to the reactor RR in **FIG. 11** at a specific flow rate.

[0154] In the FF ratio storage means **17**, the flow factor ratio for N_2 gas, that is 1, is selected. In the flow rate calculator **18**, it is found from $Q=1 \times Q_c$ that $Q=Q_c$. The flow rate display means **19** displays the flow rate Q_c of N_2 gas.

[0155] Then, the gas type selection circuit **15** selects O_2 gas, and its set flow rate Q_e is specified by the flow rate setting circuit **16**. The aforesaid constant K is set for N_2 gas, and therefore the signal Q_e is set in terms of N_2 gas in the present example. Similarly, the control valve **2** is so adjusted that the flow rate Q_c calculated by the equation $Q_c = KP_1$ becomes equal to Q_e .

[0156] Even if the calculated Q_c is equal to the flow rate setting signal Q_e , the gas actually flowing through the orifice **8** is O_2 gas. The actual gas flow rate Q through the orifice **8** is $Q = FF_O / FF_N \times Q_c$.

[0157] In the FF ratio storage means **17**, therefore, FF_O / FF_N is selected as flow factor ratio. In the flow rate calculator **18**, the O_2 gas flow rate is calculated by the equation $Q = FF_O / FF_N \times Q_c$, and the calculated value is shown on the flow rate display means **19**.

[0158] In the present embodiment, even if O_2 gas is selected, the flow rate setting circuit **16** does not specify the actual flow rate but outputs the flow rate setting signal Q_e in terms of the corresponding N_2 gas flow rate.

Example 6

A Second Example of Fluid Switchable Pressure-type Flow Control System

[0159] **FIG. 13** is a block diagram of a second embodiment of the fluid switchable pressure-type flow control system improved in that point. What is different from **FIG. 3** is that there is added an FF inverse ratio calculation circuit **21** with an FF ratio storage means **17**.

[0160] If, for example, the gas type selection circuit **15** selects the O_2 gas, the flow rate setting circuit **16** outputs the actual flow rate of O_2 gas as flow rate setting signal Q_e . This signal Q_e is converted into the flow rate corresponding to that of N_2 gas by the FF inverse ratio calculation circuit **21** using the FF ratio of the FF ratio storage means **17**. That is, Q_e is multiplied by the reciprocal number of the FF ratio and converted into the signal Q_k corresponding to that of N_2 gas by the equation $Q_k = 1 / (FF_O / FF_N) \times Q_e$. That is because the fluid switchable pressure-type flow control system is initialized with N_2 gas.

[0161] In the embodiment of **FIG. 13**, the flow rate calculator **18** is not needed. Since the flow rate setting signal Q_e itself is the flow rate of O_2 gas, all that has to be done is to show this flow rate setting signal Q_e on the flow rate display means **19**. Needless to say, the same is the case with H_2 gas and N_2 gas.

[0162] To summarize, the parallel divided flow type fluid supply apparatus according to the present invention can minimize the effect on other flow passages of a flow passage being opened to allow fluid to flow, because a mass flow controller is provided with a time delay feature. Therefore,

the other flow passages can be maintained in a steady flow state. One regulator can control a plurality of flow passages in a steady flow state.

[0163] In the apparatus according to fourth embodiment, the delay time of the mass flow controller can be freely changed and set. The apparatus achieves the most effective control to keep the flow rate steady.

[0164] In the apparatus according to the fourth embodiment, a pressure-type flow control system is adopted as a flow controller that permits high-speed control of the flow rates of the respective flow passages. The high-speed action can absorb the interfering transient changes among the flow passages, thereby making it possible to control and keep the respective flow passages in a steady state at a high speed and without failure.

[0165] The invention according to yet another embodiment provides a method of using one pressure-type flow control system for a number of different types of gases, because even if the pressure-type flow control system is initialized for gas type A (N_2 gas, for example), the flow rate can be converted through the flow factor into the flow rate of any gas type B. Thus materialized is a method of dealing with a wide range of gas types at low cost and with high precision unlike the prior art flow rate control apparatus using a mass flow meter or the flow control method in which the mass flow meter is merely replaced with the pressure-type flow control system.

[0166] While the invention has been particularly shown and described with reference to preferred embodiments, it will be understood by those skilled in this art that various changes and modifications may be made therein without departing from the spirit and scope of the invention.

LIST OF REFERENCE NUMBERS AND CHARACTERS

- [0167] AMP, AP_1 , AP_2 =amplifiers
- [0168] A/D=A-D converter
- [0169] BG=bridge circuit
- [0170] BP=bypass circuit
- [0171] C=reaction chamber
- [0172] CC=comparison circuit
- [0173] CV=control valve
- [0174] CCC=calculation control circuit
- [0175] $DMFC_1$, $DMFC_2$ =time delay type mass flow controllers
- [0176] DP=display
- [0177] DT=time delay unit
- [0178] DS=downstream sensor
- [0179] DV=drive
- [0180] FCS_1 , FCS_2 =pressure-type flow control systems
- [0181] M=temperature compensator
- [0182] MFC=mass flow controller
- [0183] MFC, MFC_1 , MFC_2 =mass flow controllers
- [0184] MFM, MFM_1 , MFM_2 =mass flow meters
- [0185] RF=orifice

- [0186] P_0, P_1A, P_2B =pressure gauges
- [0187] P_1 =pressure on the upstream side of the orifice
- [0188] P_2 =pressure on the downstream side of the orifice
- [0189] P_s =power source
- [0190] Q_c =calculated flow rate
- [0191] Q_s =set flow rate
- [0192] RG, RG_1, RG_2 =regulators
- [0193] S_1, S_2 =flow passages
- [0194] SP =sensor
- [0195] SS, ST =flow rate setting means
- [0196] t_0 =short stop time
- [0197] Δt =delay time
- [0198] US =upstream sensor
- [0199] VP =valve unit
- [0200] $V_1 \sim V_4, VV, VV_1, VV_2$ =valves
- [0201] VP_1, VP_2 =vacuum pumps
- [0202] 2=control valve
- [0203] 4=drive unit
- [0204] 6=pressure detector
- [0205] 8=orifice
- [0206] 12=joint for taking out gas
- [0207] 14=circuit for calculation of flow rate
- [0208] 15=circuit for selection of gas type
- [0209] 16=circuit for setting the flow rate
- [0210] 17=FF ratio storage means
- [0211] 18=flow rate calculation means
- [0212] 19=flow rate display means
- [0213] 20=calculation control circuit
- [0214] 21=FF inverse ratio calculation circuit
- [0215] 22, 24=amplifier
- [0216] 23=temperature detector
- [0217] 26, 28=a-d converters
- [0218] 30=temperature compensation circuit
- [0219] 33=calculation circuit
- [0220] 34=comparison circuit
- [0221] 36=amplification circuit
- [0222] FCS_1 =pressure-type flow control system
- [0223] FCS_{2a} =pressure-type flow control system
- [0224] Q_c =calculated flow rate signal
- [0225] Q_e =flow rate setting signal
- [0226] Q_k =signals corresponding to the flow rate of N_2 gas
- [0227] $V_1a \sim V_4a$ =valves
1. A parallel divided flow fluid supply apparatus, comprising:
- a pressure regulator having an upstream side and a downstream side;
 - a plurality of parallel flow passages disposed downstream of said pressure regulator, wherein a single flow fluid from said pressure regulator is branched into said parallel flow passages;
 - a plurality of flow control valves disposed in said flow passages; and
 - a plurality of time delay mass flow controllers for controlling of the flow rate, one controller installed on each flow passage between two of said flow control valves disposed upstream and downstream of said controller respectively, wherein said time delay-type mass flow controller on a flow passage is so set that when the mass flow controller is actuated to open the passage for a steady flow state at a preset flow rate, a delay time is allowed for the flow rate to rise from the starting point to the preset flow rate value.
2. A parallel divided flow fluid supply apparatus as defined in claim 1, wherein said delay time is adjustable.
3. A parallel divided flow fluid supply apparatus as defined in claim 1, wherein said time delay mass flow controller comprises:
- a sensor section disposed immediately downstream of the upstream flow control valve of said controller for detecting an instantaneous flow rate of fluid coming through the upstream flow control valve; wherein said sensor section comprises an upstream sensor for generating heat and a downstream sensor for detecting the heat generated by said upstream sensor;
 - a means connected to said sensor section for calculating an instantaneous flow rate using signals from said sensor section;
 - an amplifier connected to said calculating means for amplifying the signals from said calculating means;
 - a valve open/close detector connected to the downstream flow control valve of said controller for detecting an open/close state of both downstream and upstream flow control valves of said controller;
 - a time delay unit connected to said valve detector for setting a delay time period during which the instantaneous flow rate gradually increases;
 - a flow rate setter connected to said time delay unit for setting a set flow rate, wherein the set flow rate will be reached during the delay time period set by said time delay unit;
 - a comparison circuit disposed between said amplifier and said time delay unit for comparing the instantaneous flow rate from said amplifier with the set flow rate set by said flow rate setter and outputting difference signals;
 - a means disposed next to said comparison circuit for receiving the outputting difference signals and displaying the outputting difference signals; and
 - a valve unit disposed downstream of said sensor section and connected to said comparison circuit for increasing

the flow rate gradually up to the set flow rate according to signals from said comparison circuit.

4. A parallel divided flow fluid supply apparatus, comprising:

- a pressure regulator having an upstream side and a downstream side;
- a plurality of parallel flow passages disposed downstream of said pressure regulator, wherein a single flow fluid from said pressure regulator is branched into said parallel flow passages;
- a plurality of flow control valves disposed in said flow passages; and
- a plurality of pressure flow control systems for controlling of the flow rate, one controller installed on each flow passage between two of said flow control valves disposed upstream and downstream of said controller respectively.

5. A parallel divided flow fluid supply apparatus of claim 4, wherein said pressure-type flow control system comprises:

- an orifice formed downstream of said control system and upstream of the downstream flow control valve for discharging fluid from the flow passage;
- a control valve installed upstream of said orifice and downstream of the upstream flow control valve of said control system for controlling the flow rate of the fluid;
- a pressure detector disposed between said orifice and said control valve for detecting the pressure P_1 between said control valve and said orifice;
- a calculation control circuit wherein with a pressure on an upstream side of said orifice set to be twice or more higher than a pressure on a downstream side of said orifice, the instantaneous flow rate is calculated as $Q_c = KP_1$ ($K = \text{constant}$) from the pressure on the upstream side of said orifice detected by said pressure detector and a difference between an instantaneous flow rate Q_c and a preset flow rate Q_s is outputted as control signal Q_y ; and
- a drive connecting said control valve and said calculation control circuit for receiving the control signals from said calculation control circuit and sending the control signals to said control valve causing said control valve operating to bring the control signal Q_y to zero.

6. A flow factor-based fluid-switchable pressure flow control method, comprising: calculating a flow rate Q_c of gas passing through an orifice according to formula $Q_c = KP_1$ (wherein $K = \text{constant}$) with a pressure P_1 on an upstream side of the orifice set at twice or more higher than a pressure P_2 on a downstream side, wherein a flow factor FF for each kind of gas is calculated as follows:

$$FF = (k/\gamma_s) \{2/(\kappa+1)\}^{1/(\kappa-1)} [\kappa/(\kappa+1)R]^{1/2}$$

wherein:

- γ_s = concentration of gas in standard state;
- κ = ratio of specific heat of gas;
- R = constant of gas; and
- K = proportional constant not depending on the type of gas;

and, wherein, if a calculated flow rate of a gas type A is Q_A and gas type B is allowed to flow through the same orifice under the same pressure on an upstream side and at the same temperature on the upstream side, a flow rate Q_B is calculated as follows:

$$Q_B = (FF_B/FF_A) Q_A$$

wherein:

FF_A = flow factor of gas type A; and

FF_B = flow factor of gas type B.

7. A flow factor-based fluid-switchable pressure flow control system, comprising:

- a control valve for controlling the flow rate of the fluid;
- an orifice formed downstream of said control valve for discharging fluid, a pressure detector disposed between said control valve and said orifice for detecting a pressure between said control valve and said orifice; and

a flow rate setting circuit, wherein a pressure P_1 on an upstream side is held to be about twice or more higher than a downstream pressure P_2 , a flow rate Q_c of a specific gas type A is calculated as $Q_c = KP_1$ (K : constant), wherein the control valve is controlled to open or close according to a difference signal between the calculated flow rate Q_c and a set flow rate Q_s , wherein storage means are provided for storing a flow factor ratio of gas type A to gas type B (FF_B/FF_A) calculated for each gas as follows:

$$FF = (k/\gamma_s) \{2/(\kappa+1)\}^{1/(\kappa-1)} [\kappa/(\kappa+1)R]^{1/2}$$

wherein:

γ_s = concentration of gas in standard state

κ = ratio of specific heat of gas;

R = constant of gas; and

K = proportional constant not depending on the type of gas;

and further comprising calculation means wherein, if a calculated flow rate of gas type A is Q_A , and, when gas type B is allowed to flow through a same orifice under a same pressure on an upstream side and at a same temperature on an upstream side, flow rate Q_B is calculated as follows:

$$Q_B = (FF_B/FF_A) Q_A.$$

8. A parallel divided flow fluid supply apparatus, comprising:

- a pressure regulator having an upstream side and a downstream side;
- a plurality of parallel flow passages disposed downstream of said pressure regulator, wherein a single flow fluid from said pressure regulator is branched into said parallel flow passages;
- a plurality of flow control valves disposed in said flow passages; and
- a plurality of flow factor-based fluid switchable pressure flow control systems for controlling of the flow rate, one controller installed in each flow passage between two of said flow control valves disposed upstream and downstream of said controller respectively;

wherein said controller comprises:

- a control valve for controlling a flow rate of the fluid;
- an orifice formed downstream of said control valve for discharging the fluid;
- a pressure detector disposed between said control valve and said orifice for detecting pressure between said control valve and said orifice; and
- a flow rate setting circuit, wherein pressure P_1 on an upstream side is held to be about twice or more higher than a downstream pressure P_2 , and the flow rate Q_c of a specific gas type A can be calculated as $Q_c = KP_1$ (K: constant), wherein the control valve is controlled to open or close according to a difference signal between a calculated flow rate Q_c and a set flow rate Q_s , further comprising a storage means for storing a flow factor ratio of gas type A to gas type B (FF_B/FF_A) which is calculated for each kind of gas as follows:

$$FF = (k/\gamma_s) \{2/(\kappa+1)\}^{1/(\kappa-1)} [\kappa/(\kappa+1)R]^{1/2}$$

wherein:

γ_s concentration of gas in standard state;

κ =ratio of specific heat of gas;

R=constant of gas;

K=proportional constant not depending on the type of gas; and

further comprising calculation means if a calculated flow rate of gas type A is Q_A , and, gas type B is allowed to flow through a same orifice under a same pressure on an upstream side and at a same temperature on an upstream side, a flow rate for gas B Q_B is calculated as follows:

$$Q_B = (FF_B/FF_A)Q_A.$$

* * * * *