

(No Model.)

G. F. CARD.
COMMUTATOR FOR DYNAMO ELECTRIC MACHINES.

No. 524,884.

Patented Aug. 21, 1894.

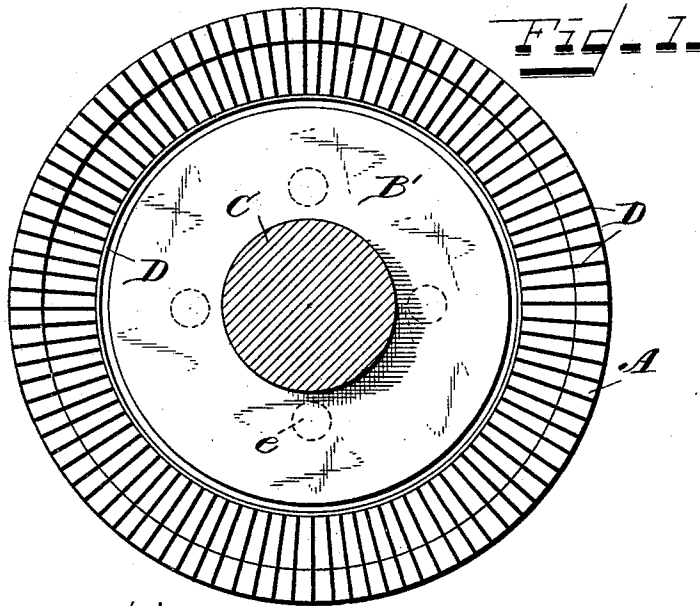

Fig. 2.

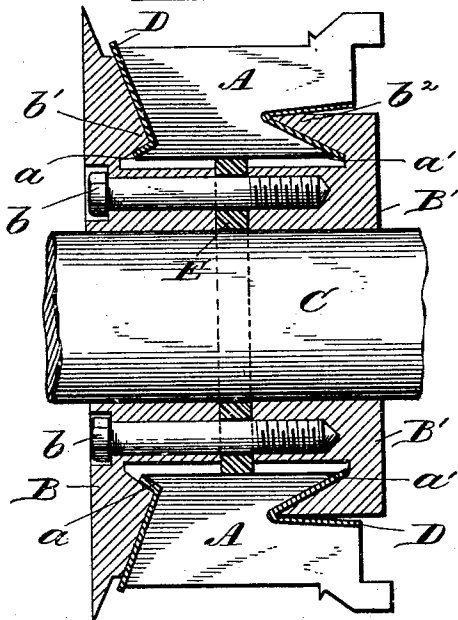
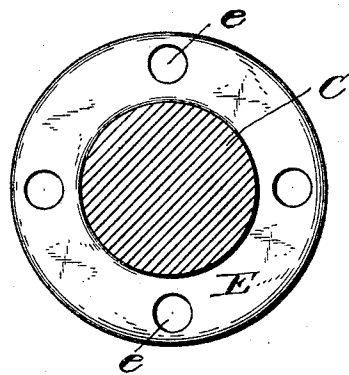

Fig. 3.



Witnesses.
Thomson Cross
P. W. Sommer.

Inventor.
George F. Card
By *Geo. B. Parkinson*
His Attorney.

UNITED STATES PATENT OFFICE.

GEORGE F. CARD, OF COVINGTON, KENTUCKY, ASSIGNOR TO THE CARD EQUIPMENT COMPANY, OF MANSFIELD, OHIO.

COMMUTATOR FOR DYNAMO-ELECTRIC MACHINES.

SPECIFICATION forming part of Letters Patent No. 524,884, dated August 21, 1894.

Application filed January 8, 1894. Serial No. 496,118. (No model.)

To all whom it may concern:

Be it known that I, GEORGE F. CARD, a citizen of the United States of America, residing at Covington, in the county of Kenton and State of Kentucky, have invented certain new and useful Improvements in Commutators for Dynamo-Electric Machines, of which the following is a specification.

My invention relates to improvements in commutators for dynamo electric machines.

Heretofore great difficulty has been experienced in mounting the commutator on the shaft of the armature so as to prevent the oil on the shaft from coming in contact with the segments of the commutator. The object of my invention is to overcome this defect; to cheapen and simplify existing constructions, reducing the number of parts and increase the efficiency.

The invention consists in means for preventing access of oil to the commutator segments and in the construction and arrangement of the cap-plates and segments.

In the drawings: Figure 1 is a side view of a commutator provided with my improvement. Fig. 2 is a cross section, and Fig. 3 is a detail view of the packing ring.

The commutator is composed of a series of sector shaped segments A mounted between clamping rings or plates B, B', hereinafter called cap-plates, bolted together by means of cap-screws *b*, and having openings for the armature shaft C. The cap-plates are provided with inwardly projecting ribs *b'*, *b*², adapted to take over ribs *a* and *a'* formed on the segments A. The rib *b*² should be of such shape and size as to afford a bearing which will support the segments while the parts are being assembled. In the form shown the outer face or periphery of the cap-plate B' is parallel with the shaft opening and affords a bearing for the segments. Insulating plates D, preferably of mica, are interposed between the segments and between the segments and the cap-plates.

To prevent the oil on the armature shaft from working between the opposing faces of the cap-plates and coming in contact with the segments of the commutator and destroying or short circuiting them, I interpose a packing ring E of some compressible non-conducting material (preferably soft rubber). The screws *b* pass through holes *e* in the packing ring; and the packing is compressed to any desired degree by the action of the screws.

If a segment is damaged or needs renewing it may be removed without dismantling the entire series. When the plate B is removed, the segments will be supported on the outer face of the rib *b*². The damaged segment may then be removed, another substituted and the plate B returned without disturbing the other segments. The ribs *b'* and *b*² hold the segments in position against the centrifugal force of the armature.

What I claim is—

1. In a commutator, the combination with the armature shaft, of cap-plates mounted thereon, a series of segments carried by the cap-plates, and a packing interposed between said plates, substantially as and for the purpose specified.

2. In a commutator, the combination with the armature shaft, of cap-plates mounted thereon, a series of segments carried by the plates, and a compressible non-conducting packing interposed between the plates, substantially as and for the purpose specified.

3. In a commutator, the combination with the armature shaft, of cap-plates mounted thereon, a series of segments carried by the plates, a rib on one of the plates adapted to support the segments independently of the other plate, and a rubber packing interposed between said plates, substantially as and for the purpose specified.

GEORGE F. CARD.

Witnesses:

JAMES N. RAMSEY,
B. W. SOMMERS.