

T. J. COULSTON.

Heating Stove.

No. 104,274.

Patented June 14, 1870.

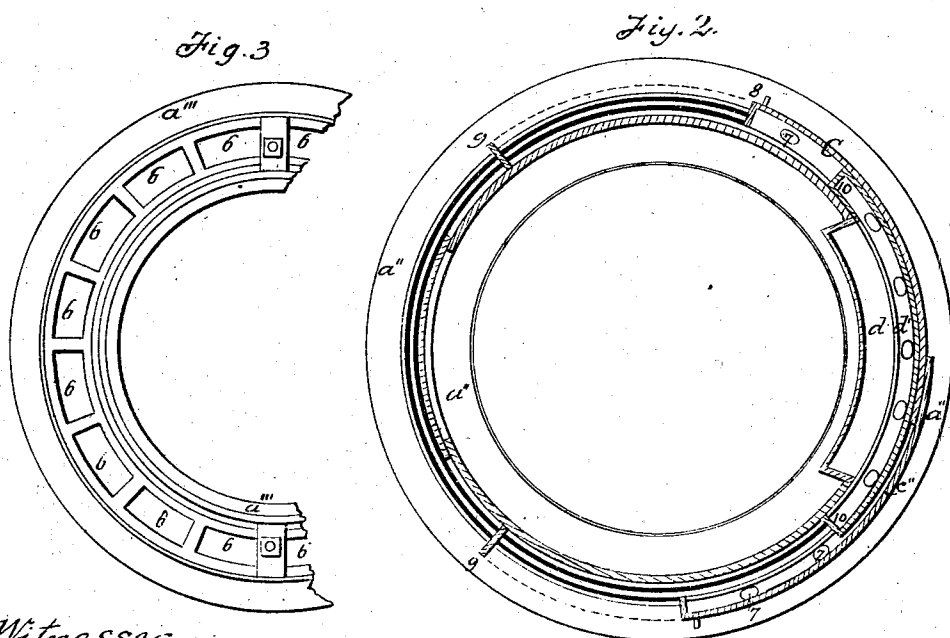
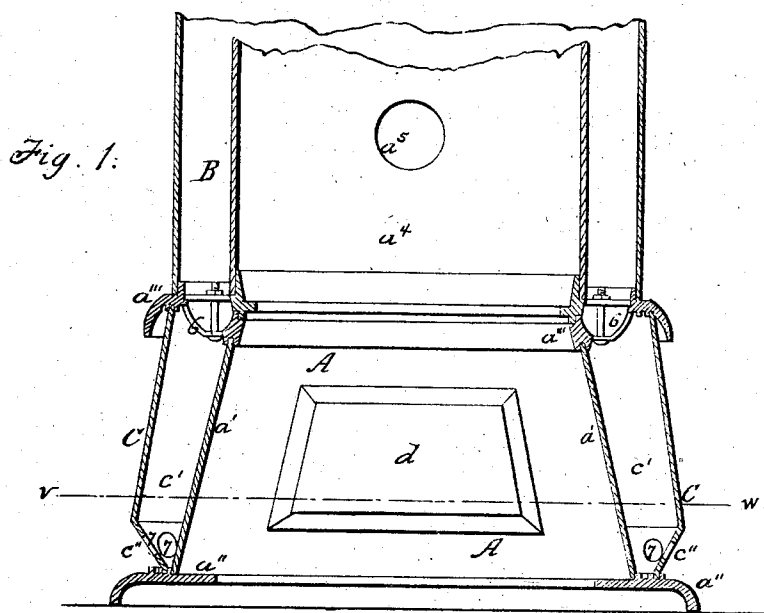

Witnesses.

Benj. Morrison
Wm. H. Morrison.

Inventor. Tho. J. Coulston

United States Patent Office.

THOMAS J. COULSTON, OF ROYER'S FORD, ASSIGNOR TO ENOS S. SHANTZ
AND OLIVER B. KEELY, OF SPRINGVILLE, PENNSYLVANIA.

Letters Patent No. 104,274, dated June 14, 1870.

IMPROVEMENT IN HEATING-STOVES.

The Schedule referred to in these Letters Patent and making part of the same.

I, THOMAS J. COULSTON, of Royer's Ford, in the county of Montgomery and State of Pennsylvania, have invented certain Improvements in Stoves for Heating and Distributing Air to warm rooms in buildings, of which the following is a specification.

Nature and Objects of the Invention.

My invention relates to the application of adjustable slides around portions of the outside of the fire-chamber of such stoves as are intended to supply warm air from the room in which they are located to the room or rooms also which are above, in the same building, so that inclosed air-heating spaces can be produced around such portions of the outside of said stove at pleasure, the object of my invention being to enable the occupant of the room in which the stove is located to increase or diminish at will the degree of heat in the air passing upward through a hot-air flue, which communicates, through holes in its supporting-ring, with the room above.

Description of the Accompanying Drawings.

Figure 1 is a vertical central section of the middle portion of an illuminating parlor-stove, with the flue for conducting warm air to the room above, and having my invention applied thereto.

Figure 2 is a horizontal section of the same, below the dotted line *vw*, of fig. 1.

Figure 3 is a sectional plan view of the flanged ring which supports the warm-air flue, with the upper part of the stove and its smoke-flue, and also forms the open top of the air-heating spaces formed by the adjustable slides.

General Description.

A is the upper part of the fire-chamber, the sloping sides, *a a'*, of which are supported upon a ring, *a''*, which rests upon the upper edges of the usual plates of the lower part of the fire-chamber, (not shown,) while their upper edges support the ring *a''*, upon which rests the hot-air-conducting flue, B, with the upper part, *a'*, of the stove, and its smoke-flue, *a'*.

The ring *a''* has a series of openings, 6-6, which allow warm air from the room to pass freely upward into the flue B.

The construction and arrangement above described are in public use and well known, and, therefore, need not be more fully described.

C C are the adjustable slides, by means of which the inclosed air-heating spaces, previously named, can be formed at will around the outside of that part

of the fire-chamber formed by the sloping sides *a a'* of the stove.

In the under side of the flange of the ring *a''* grooves are cast for the reception and the sliding motions of the upper edges of the respective slides C C, which are curved to correspond with the curves of the grooves, and, in the upper side of the flange of the ring *a''*, like grooves are cast for the reception and the motions of the lower edges of the said slides.

The slides C C are each made to have an inward slope, *c'*, at their lower parts, which sloping part of each is perforated with a series of large holes, 7-7, and each slide corresponds in length with about one-fourth, more or less, of the circumference of that part of the stove at which they are placed, (see fig. 2,) and when closed, so as to produce the air-heating space required at the right and left-hand sides of the stove, their front ends, 8, are close up against a vertical radial plate, 9, while a like radial plate, 10, which forms the end of the cover *d'* of a stationary recessed hot-air space, *d*, at the rear side of the stove, closes the rear end of the hot-air space produced by the said closed slide C.

When the slides C C are pushed fully back, the one overlaps the other behind the cover *d'* of the stationary hot-air space *d*, and thus opens the space previously covered by C, and allows the heat of that part of the fire-chamber to radiate into the room, with the exception of a small portion carried up by the draught of the flue B, but when the slides are closed against their respective radial plates 9 9, the inclosed air-heating spaces required are produced, and prevent free radiation of heat into the room therefrom, and cause the air of the room to pass into the said spaces, through the series of holes 7 7, and become strongly heated therein before it passes into the flue B.

It will be understood, without further explanation, that the adjustable slides C C afford a ready, simple, and effective means for apportioning the heat of the stove between the room below and the room above of the dwelling, as occasion may require.

Claim.

I claim as my invention—

The adjustable slides C C, in combination with the rings *a'* and *a''*, and the radial end closing plates 9 and 10, the said parts being arranged to operate substantially as and for the purpose hereinbefore set forth.

Witnesses: THOS. J. COULSTON.

BENJ. MORISON,
WM. H. MORISON.