

(No Model.)

J. O. MITCHELL.
CAR COUPLING.

No. 521,887.

Patented June 26, 1894.

Fig I.

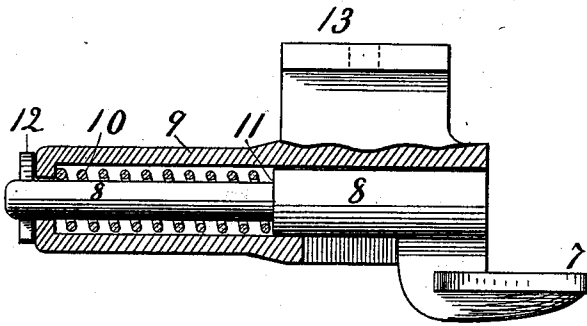

Fig II.

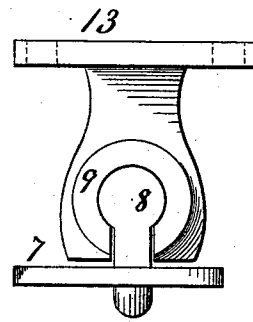
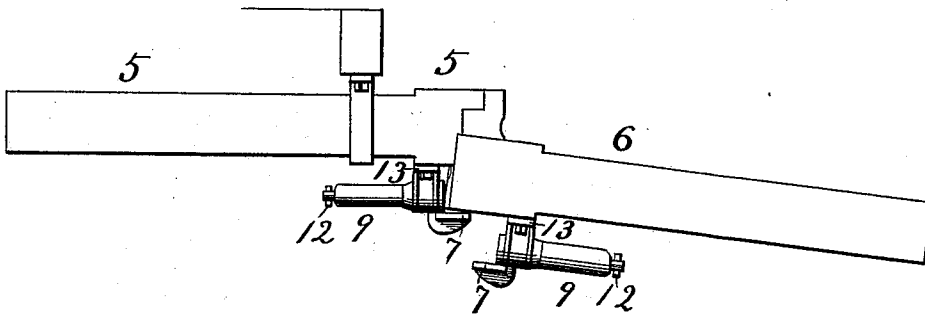

Fig III.



WITNESSES.

P. Egbert Stevens.
Wm. C. Hillyard.

INVENTOR.

James O. Mitchell.
by *W. G. Stevens.* ATTORNEY.

UNITED STATES PATENT OFFICE.

JAMES O. MITCHELL, OF STUART'S DRAFT, ASSIGNOR OF ONE-HALF TO SARAH ELIZABETH RANKIN, OF BASIC CITY, VIRGINIA.

CAR-COUPLING.

SPECIFICATION forming part of Letters Patent No. 521,887, dated June 26, 1894.

Application filed November 9, 1893. Serial No. 490,475. (No model.)

To all whom it may concern:

Be it known that I, JAMES O. MITCHELL, a citizen of the United States, residing at Stuart's Draft, in the county of Augusta and State of Virginia, have invented certain new and useful Improvements in Car-Couplings; and I do hereby declare the following to be a full, clear, and exact description of the invention, such as will enable others skilled in the art to which it appertains to make and use the same.

This invention relates to automatic car couplings of the Janney type, or such as are provided with horizontally swinging hooks adapted to engage one another sidewise, and its object is to provide novel means for holding two couplings engaged so as to prevent either of them from falling upon the track in case it should be broken in service, such novel means being adapted for attachment to drawheads already in service and for ready removal for the purpose of repairs so that the whole drawhead need not be thrown away nor put out of service merely on account of breaking a holder.

To this end my invention consists in the construction and combination of parts forming a car coupling, hereinafter described and claimed, reference being had to the accompanying drawings, in which—

Figure I, is a longitudinal vertical section of that portion of a car coupling which constitutes my invention. Fig. II, is a front end view of the same. Fig. III, represents a portion of a car coupling in side elevation showing my invention in service.

5 represents one drawhead and 6 its mate, the two being coupled together and the head 6 in position as though it were pulled out of a car and held suspended by the bar 5.

7 represents a shelf provided with a cylindrical shank 8, that is fitted to telescope within a socket 9.

10 is a spring coiled around the shank and acting between a shoulder 11 thereof and the inner end of the socket to push the shelf outward.

12 is a key through the shank to keep it from being accidentally removed or lost from the socket.

13 is a base-piece of the socket which is to be shaped to fit the under side of that drawhead on which this invention is to be used. Differently shaped drawheads will require differently shaped base-pieces to fit them, but this portion of various drawheads is usually flat so that one base-piece will fit them all and may be fastened thereon with common bolts. When the socket is thus bolted in place the shelf is located below the mouth of the drawhead and is adapted to slide back underneath the socket flush with the front end thereof when met by an incoming drawhead that is very low, and yet this shelf is located at a distance below its own drawhead a little less than the vertical thickness of each of the drawheads to allow the greatest practicable latitude for variation in the height of drawheads of different cars and yet prevent two from becoming separated vertically after they are once coupled. If any two drawheads are near enough to one level to be coupled at all the working of the car will soon raise the lower one so that the shelf will shoot out under it and then it can not again get low enough to be in danger of uncoupling. If the socket were made integral with the drawhead as a projection from its under side there would be danger of its being broken off in the extremely rough service that the drawheads of cars are exposed to, and in case of such breakage the whole drawhead would be destroyed, but by means of my removable socket a new socket may be quickly bolted on in place of the broken one, even while the car is on the road, and the drawhead is not only saved but the service of the car is not interrupted.

Having thus described my invention, what I believe to be new, and desire to secure by Letters Patent, is the following:

1. The combination in car couplings of a drawhead adapted to be hooked sidewise to its mate; a shelf provided with a shank; a socket fitted for the said shank to telescope within it and adapted to be bolted to the drawhead with the shelf projecting below the mouth of the drawhead, and a spring acting between the socket and shank to project the shelf, substantially as described.

2. The combination of a socket adapted to be bolted to the drawhead of a car coupling; a shelf provided with a shank fitted to telescope within the socket, and a spring acting between the socket and shank to project the shelf substantially as described whereby the shelf may be held below the mouth of the drawhead to prevent another drawhead

coupled therewith from falling away from its mate.

In testimony whereof I affix my signature in presence of two witnesses.

JAMES O. MITCHELL.

Witnesses:

WM. H. DE LACY,
M. C. HILLYARD.