

March 14, 1933.

R. H. STOKES ET AL

1,901,827

PUMPING UNIT

Filed June 6, 1931

2 Sheets-Sheet 1

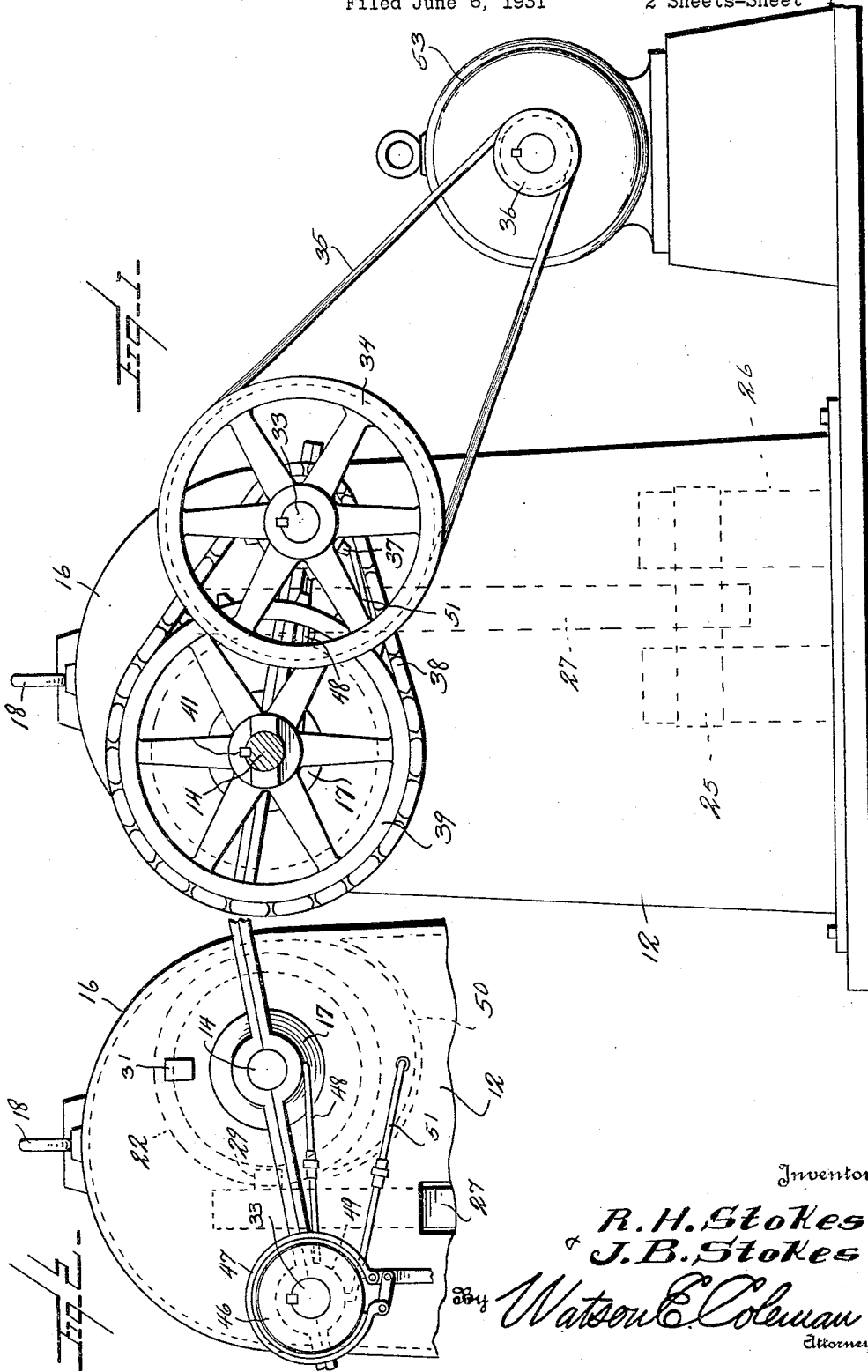

Inventors

R. H. Stokes
& J. B. Stokes

Watson E. Coleman
Attorney

March 14, 1933.

R. H. STOKES ET AL

1,901,827

PUMPING UNIT

Filed June 6, 1931

2 Sheets-Sheet 2

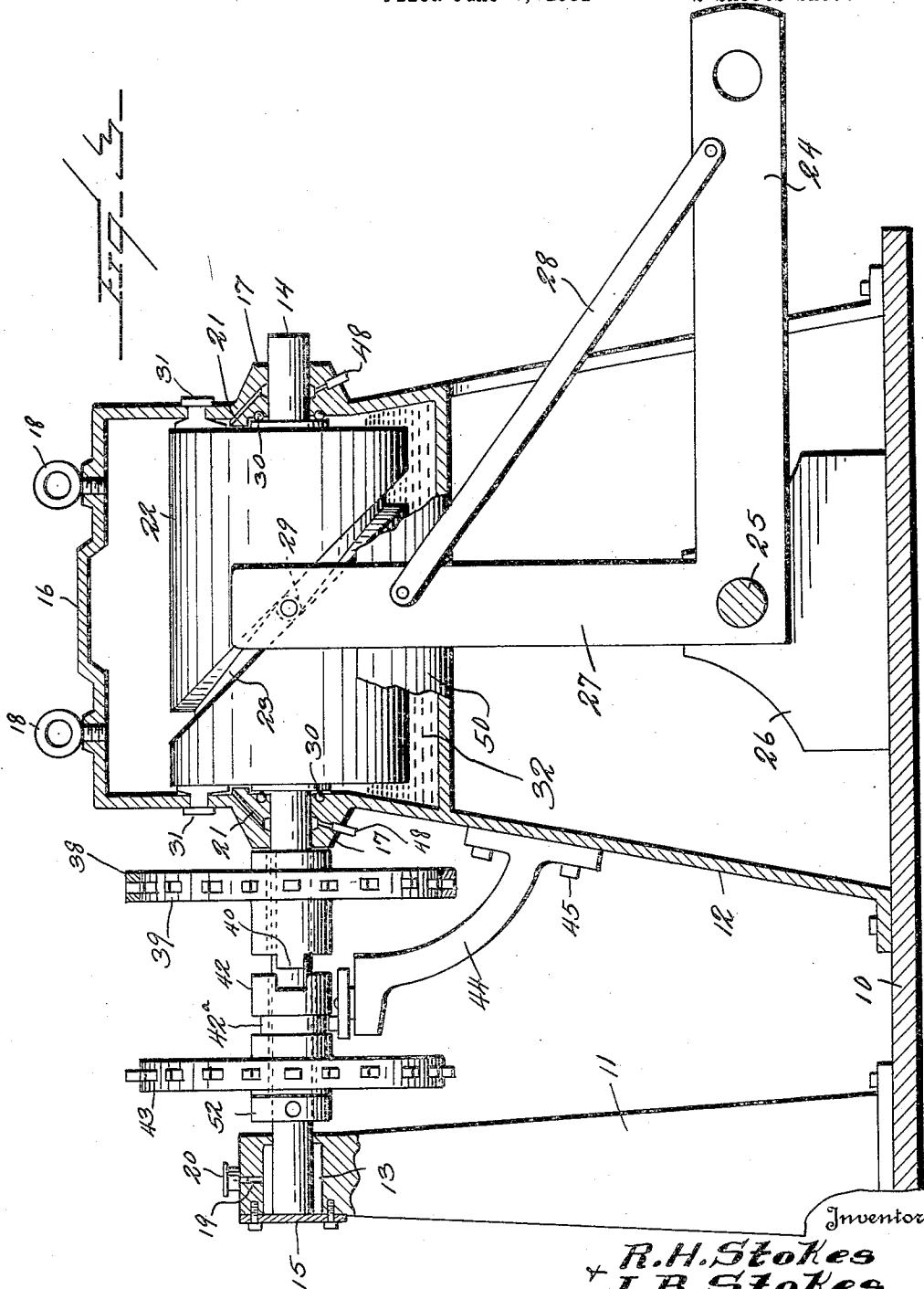

Inventors

R.H. Stokes
+ J.B. Stokes

By *Watson E. Coleman*
Attorney

UNITED STATES PATENT OFFICE

ROBERT H. STOKES AND JAMES B. STOKES, OF LUFKIN, TEXAS

PUMPING UNIT

Application filed June 6, 1931. Serial No. 542,604.

This invention relates to well pumping apparatus, and more particularly to a pumping jack.

5 An object of this invention is to provide means by which rotary motion from a rotary power member may be changed to oscillatory or reciprocating motion so as to reciprocate a pumping rod within a well.

10 Another object of this invention is to provide in a construction of this kind means by which the driving member may be readily mounted or disposed in a lubricant so as to prevent undue wearing of the working parts thereof.

15 A further object of this invention is to provide a unit of this kind which may be readily moved from well to well and connected up to a suitable power member for operation of the well pumping parts.

20 A still further object of this invention is to provide in a construction of this kind means by which the rotating parts of the device may be readily stopped and held in desired position.

25 The above and various other objects and advantages of this invention will in part be described in and in part be understood from the following detailed description of the present preferred embodiment, the same being illustrated in the accompanying drawings, wherein:—

Figure 1 is a detail end elevation of one end of a device constructed according to the preferred embodiment of this invention;

35 Figure 2 is a fragmentary detail end elevation of the opposite end of the device, and

Figure 3 is a longitudinal section partly in detail taken substantially through the longitudinal center of the device.

40 Referring to the drawings wherein like numerals of reference designate corresponding parts throughout the several views, the numeral 10 designates generally a base having an upstanding standard 11 disposed thereupon. A housing or standard, generally

designated as 12, is mounted on the base 10 and a driven shaft 14 is rotatably mounted on the standards 11 and 12.

An anti-friction bearing element 13 is carried by the standard 11 and engages about the driven shaft 14, which driven shaft is held against movement in one direction with respect to the standard 11 by means of a cap plate 15, which is secured to the outer face of the standard 11 and across the end of the driven shaft 14. The standard 12 has mounted thereupon a housing 16, which has bearings 17 for rotatably receiving the driven shaft 14. This housing 16 is provided with eye bolts 18 in the top thereof, so that the entire unit mounted on the base 10 may be readily lifted by means of a crane or the like attached to the eye bolts. A lubricating channel 19 is provided in the standard 11 which communicates with the anti-friction element 13 and a lubricating element 20 is mounted in the channel 19 and normally closes this channel so as to prevent the entrance of dirt or the like. In like manner, the bearings 17 are provided with lubricating channels 21 which communicate with the interior of the housing 16.

A driven member in the form of a drum 22 is secured to the shaft 14 within the housings 12 and 16, and this drum 22 is provided with a cam groove 23. A pitman 24 is mounted on a shaft 25, which shaft 25 is mounted in bearings 26 carried by the base 10, and this pitman 24 is adapted to have vertical oscillatory movement with respect to the base 10. A vertically disposed arm 27 is mounted on the shaft 25 and a bracing member 28 connects the pitman 24 with the vertical arm 27 so that the pitman 24 will rock coactively with the rocking movement of the vertical arm 27.

In practice, this pitman 24 and the arm 27 may be formed integrally or, if desired, secured in any desired manner to the rock shaft 25. An inwardly extending roller element 29 is mounted on the vertical arm 27 and ex-

tends into the cam groove 23. In this manner, when the drum 22 is rotated, the roller element 29 will roll within the groove 23 and rock the vertical arm 27 and coactively vertically rock the pitman 24. Anti-friction elements or thrust bearings 30 are disposed on the opposite ends of the drum 22 and engage against the inner faces of the ends of the housing 16. A pair of wiper members 31 are mounted one in each end of the housing 16 and have a channel therein communicating with the lubricating channels 21 in the bearings 17 so that as the drum 22 rotates, these wiping elements 31 will wipe the ends of the drum and remove therefrom a quantity of lubricant 32, which is mounted in the lower portion of the housing 16 so that the bearings for the shaft 14 will be thoroughly lubricated at all times.

In order to drive the driven member 22, we have provided a driving shaft 33 which is mounted in offset relation to the driven shaft 14 on the standard 11 and the standard 12. This driving shaft 33 has a relatively large pulley or wheel 34 keyed thereto, this pulley 34 having a flexible belt or member 35 trained thereover, the belt being also trained over a rotating pulley 36 mounted on a motor or other power member. A driving sprocket 37 is keyed to the shaft 33 inwardly of the wheel 34 and a chain or flexible member 38 is trained over this drive sprocket 37, the chain also engaging over a driven sprocket 39, which is secured by a key 41 on the driven shaft 14.

A one-half portion of a dental clutch is secured or formed with the hub of the driven sprocket 39 which is keyed to the shaft 14, and a power takeoff sprocket 43 is rotatably mounted on the shaft 14, this sprocket being provided with a one-half portion 42 of a dental clutch for selective engagement with the first half portion 40 so as to rotate the takeoff sprocket 43 coactively with the rotation of the driven sprocket 39. This clutch element 42 has a peripheral groove 42^a therein for receiving the conventional clutch collar which may be operated by clutch operating members carried by a bracket member 44 secured to the housing or standard 12 by means of bolts 45 or the like. This clutch element 42, together with the sprocket 43 is provided with a bronze bushing or the like, and the sprocket 43 is adapted to be connected to means for pulling rods from wells or for driving a rotary rig or hoists. A brake drum 46 is secured to the driving shaft 33 at the end opposite from the driving pulley 37 and a brake band 47 is disposed about the brake drum 46 and is adapted to stop rotation of the braking drum and coactively stop rotation of the driven drum 22 and rocking of the pitman 24.

In order to properly lubricate the bearings for the driving shaft 33, we have provided lubricating pipes 48 which connect

with the bearings 17. The oil entering the bearings 49 for the driving shaft 33 will return to the lubricant reservoir 50 through a downwardly inclined pipe connection 51. In this manner, the lubricant 32 in the casing 16 will be returned from the bearings back to the reservoir. A collar or annulus 52 is disposed about the driven shaft 14 intermediate the sprocket wheel 43 and the standard 11, and is adapted to hold the sprocket wheel 43 against longitudinal movement.

In the operation of this device, when the power member 53 is operated so as to rotate the driving pulley 34 and the driving shaft 33, the driving sprocket 37 will carry the chain about therewith and rotate the driven pulley 39 which is keyed to the shaft 14. When the clutch element 40 is disengaged from the clutch element 41, which is formed as a part of the sprocket 43, the takeoff sprocket 43 will idle on the shaft 14. When the clutch element 41 is moved into engagement with the complementary clutch element 40, the sprocket 43 will rotate with the shaft 14, thereby providing means for operating other well drilling equipment such as hoists, rigs, pulling rods or casings from the well. Upon rotation of the driven drum 22, the pin 29 carried by the vertical arm 27 will travel in the groove 23 and vertically oscillate the vertical arm 27, so as to coactively oscillate the pitman 24. In this manner, the rotary motion of the driven drum 22 will be transferred to reciprocating or oscillatory motion and the pumping mechanism reciprocated within the well casing.

It is, of course, understood that various changes and modifications may be made in the details of construction and design of the above specifically described embodiment of this invention without departing from the spirit thereof, such changes and modifications being restricted only by the scope of the following claim.

We claim:—

A well pumping unit of the character described comprising a base, a standard mounted on the base, a shaft rotatably mounted on the standard, a drum secured to said shaft, said drum having a cam groove therein, a pitman shaft, a pitman mounted at one end on said pitman shaft and having the opposite end disposed beyond one edge of the base, an oscillatable arm mounted on said pitman shaft and adapted to oscillate with said pitman shaft, an inwardly extending pin carried by said arm and extending into said cam groove whereby to oscillate said arm upon rotation of said drum, a casing disposed about said drum, wipers carried by the casing and engaging each end of the drum, the casing having outwardly directed lubricating channels receiving a lubricant from the wipers to lubricate the shaft, a driven wheel

mounted on said shaft outwardly of said casing, a power takeoff member rotatable on said shaft, coacting clutch elements carried by said driven wheel and said power takeoff member, a drive shaft rotatably carried by said standard, a drive wheel mounted on said drive shaft, a flexible member engaging said drive wheel and said driven wheel, and braking means carried by said drive shaft whereby to stop rotation of said driven shaft upon declutching thereof.

In testimony whereof we hereunto affix our signatures.

ROBERT H. STOKES.
JAMES B. STOKES.

15

20

25

30

35

40

45

50

55

60

65