



- (51) International Patent Classification:
G01D 5/14 (2006.01)
- (21) International Application Number:
PCT/US2015/055233
- (22) International Filing Date:
13 October 2015 (13.10.2015)
- (25) Filing Language: English
- (26) Publication Language: English
- (30) Priority Data:
14/529,669 31 October 2014 (31.10.2014) US
- (71) Applicant: ALLEGRO MICROSYSTEMS, LLC
[US/US]; 115 Northeast Cutoff, Worcester, Massachusetts
01606 (US).

- (72) Inventors: DAVID, Paul, A.; 10 Risingwood Drive, Bow,
New Hampshire 03304 (US). TAYLOR, William, P.; 1
Highland Drive, Amherst, New Hampshire 03031 (US).
- (74) Agents: ROBINSON, Kermit et al.; Daly, Crowley, Mof-
ford & Durkee, LLP, Suite 301A, 354A Turnpike Street,
Canton, Massachusetts 02021 (US).
- (81) Designated States (unless otherwise indicated, for every
kind of national protection available): AE, AG, AL, AM,
AO, AT, AU, AZ, BA, BB, BG, BH, BN, BR, BW, BY,
BZ, CA, CH, CL, CN, CO, CR, CU, CZ, DE, DK, DM,
DO, DZ, EC, EE, EG, ES, FI, GB, GD, GE, GH, GM, GT,
HN, HR, HU, ID, IL, IN, IR, IS, JP, KE, KG, KN, KP, KR,
KZ, LA, LC, LK, LR, LS, LU, LY, MA, MD, ME, MG,
MK, MN, MW, MX, MY, MZ, NA, NG, NI, NO, NZ, OM,
PA, PE, PG, PH, PL, PT, QA, RO, RS, RU, RW, SA, SC,
SD, SE, SG, SK, SL, SM, ST, SV, SY, TH, TJ, TM, TN,
TR, TT, TZ, UA, UG, US, UZ, VC, VN, ZA, ZM, ZW.

[Continued on next page]

(54) Title: MAGNETIC FIELD SENSOR PROVIDING A MOVEMENT DETECTOR

(57) Abstract: A magnetic field sensor has a plurality of magnetic field sensing elements and operates as a motion detector for sensing a rotation or other movement of a target object.

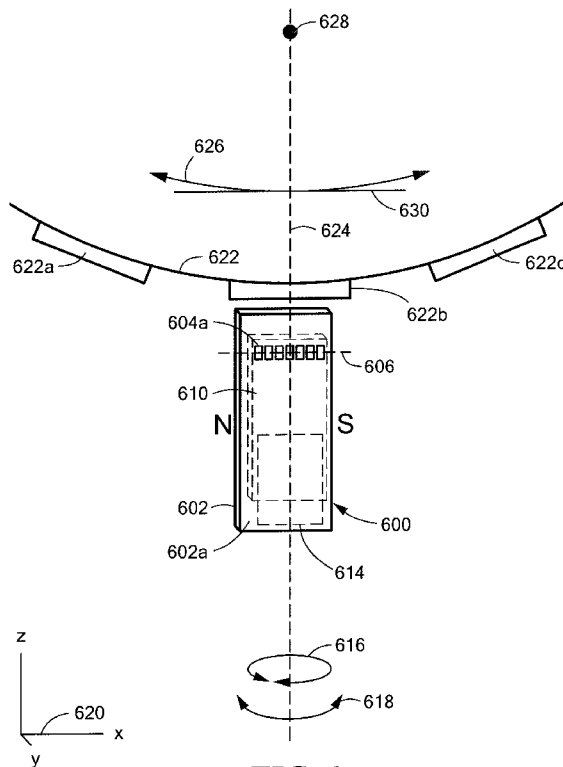

FIG. 6

WO 2016/069254 A1

(84) Designated States (*unless otherwise indicated, for every kind of regional protection available*): ARIPO (BW, GH, GM, KE, LR, LS, MW, MZ, NA, RW, SD, SL, ST, SZ, TZ, UG, ZM, ZW), Eurasian (AM, AZ, BY, KG, KZ, RU, TJ, TM), European (AL, AT, BE, BG, CH, CY, CZ, DE, DK, EE, ES, FI, FR, GB, GR, HR, HU, IE, IS, IT, LT, LU, LV, MC, MK, MT, NL, NO, PL, PT, RO, RS, SE, SI, SK, SM, TR), OAPI (BF, BJ, CF, CG, CI, CM, GA, GN, GQ, GW, KM, ML, MR, NE, SN, TD, TG).

Declarations under Rule 4.17:

- *as to applicant's entitlement to apply for and be granted a patent (Rule 4.17(ii))*
- *as to the applicant's entitlement to claim the priority of the earlier application (Rule 4.17(iii))*

Published:

- *with international search report (Art. 21(3))*

MAGNETIC FIELD SENSOR PROVIDING A MOVEMENT DETECTOR

FIELD OF THE INVENTION

This invention relates generally to magnetic field sensors, and, more particularly, to magnetic field sensors having a substrate with magnetic field sensing elements thereupon to sense a motion of a ferromagnetic object, all arranged in a variety of relative positions.

BACKGROUND

Various types of magnetic field sensing elements are known, including Hall Effect elements and magnetoresistance elements. Magnetic field sensors generally include a magnetic field sensing element and other electronic components. Some magnetic field sensors also include a permanent magnet (a hard ferromagnetic object) in a so-called "back biased" arrangement described more fully below. Other magnetic field sensors sense motion of a magnet.

Magnetic field sensors provide an electrical signal representative of a sensed magnetic field. In some embodiments that have the magnet (back-biased arrangements), the sensed magnetic field is a magnetic field generated by the magnet, in which case, in the presence of a moving ferromagnetic object, the magnetic field generated by the magnet and sensed by the magnetic field sensor varies in accordance with a shape or profile of the moving ferromagnetic object. In contrast, magnetic field sensors that sense a moving magnet directly sense variations of magnetic field magnitude and direction that result from movement of the magnet.

Magnetic field sensors (back-biased) are often used to detect movement of features of a ferromagnetic gear, such as gear teeth and/or gear slots or valleys. A magnetic field sensor in this application is commonly referred to as a "gear tooth" sensor.

In some arrangements, the gear (a target object) is placed upon another object, for example, a camshaft in an engine. Thus, it is the rotation of both the target object (e.g., gear) and the other object (e.g., camshaft) that is sensed by detection of the moving features of the gear. Gear tooth sensors are used, for example, in automotive applications

to provide information to an engine control processor for ignition timing control, fuel management, anti-lock braking systems, wheel speed sensors, and other operations.

Information provided by the gear tooth sensor to the engine control processor can include, but is not limited to, an absolute angle of rotation of a target object (e.g., a camshaft) as it rotates, a speed of the rotation, and a direction of the rotation. With this information, the engine control processor can adjust the timing of firing of the ignition system and the timing of fuel injection by the fuel injection system.

Many types of magnetic field sensors do not provide an accurate output signal (e.g., indication of absolute angle, speed, or direction of rotation) immediately upon power up, upon movement of the target object from zero rotating speed, and/or upon movement slowing to zero rotating speed, but instead provide an accurate output signal only once the target object has moved through a substantial rotation or is moving with substantial speed. For example, in one type of magnetic field sensor described in U.S. Patent No. 6,525,531, entitled "Detection of Passing Magnetic Articles while Adapting the Detection Threshold," issued February 25, 2003, a positive digital-to-analog converter (PDAC) and a negative digital-to-analog converter (NDAC) track positive and negative peaks of a magnetic field signal, respectively, for use in generating a threshold signal. A varying magnetic field signal is compared to the threshold signal. However, the outputs of the PDAC and the NDAC may not be accurate indications of the positive and negative peaks of the magnetic field signal until several cycles of the signal (i.e., signal peaks) occur (i.e., until several gear teeth have passed). This type of magnetic field sensor, which generally requires time to become fully accurate, is referred to herein as a so-called "precision rotation detector."

In contrast, a "true power on state" (TPOS) detector can provide an accurate output signal shortly after movement of a target object (e.g., camshaft) from zero rotating speed, or a low rotation speed in some applications of, for example, less than 100 rpm, or also shortly before movement slowing to zero rotating speed. Furthermore, even when the target object is not moving, the TPOS detector can provide an indication of whether the TPOS detector is in front of a tooth or a valley of a gear. However, when the target object

is stationary, the conventional TPOS detector is not able to identify an absolute or relative angle of rotation of the target object. The TPOS detector can be used in conjunction with a precision rotation detector within a common integrated circuit, each providing information to the engine control processor at different times. For simplicity, TPOS
5 detectors and precision rotation detectors are shown herein within a common integrated circuit. However, the TPOS detector or the precision rotation detector can also be used alone in separate circuits.

As described above, the conventional TPOS detector provides an accurate output
10 signal with only a small initial rotation of the target object, and before the precision rotation detector can provide an accurate output signal. The TPOS detector can provide information to the engine control processor that can be more accurate than information provided by the precision rotation detector for time periods at the beginning and at the end of rotation of the target object (e.g., start and stop of the engine and camshaft), but which
15 may be less accurate when the object is rotating at speed. For magnetic field sensor arrangements that have both a TPOS detector and a precision rotation detector within a common integrated circuit, when the object is not rotating or rotating slowly, the engine control processor can use the TPOS detector. When rotating at speed, the engine control processor can primarily use rotation information provided by the precision rotation
20 detector. In most conventional applications, once the magnetic field sensor switches to use the precision rotation detector, it does not return to use the TPOS detector until the target object stops rotating or nearly stops rotating.

A conventional TPOS detector is described in U.S. Patent No. 7,362,094, entitled
25 "Method and Apparatus for Magnetic Article Detection," issued April 22, 2008. The conventional TPOS detector includes a comparator for comparing the magnetic field signal to a fixed, often trimmed, threshold signal. The conventional TPOS detector can be used in conjunction with and can detect rotational information about a TPOS cam (like a gear), which is disposed upon a target object, e.g., an engine camshaft, configured to
30 rotate.

An example of an output signal from a conventional TPOS detector has at least

two states, and typically a high and a low state. The state of the conventional TPOS output signal is high at some times and low at other times as the target object rotates, in accordance with features on the TPOS cam (or gear) attached to the target object.

5 Similarly, an output signal from a conventional precision rotation detector also has at least two states, and typically a high and a low state. The state of the conventional precision rotation detector output signal is high at some times and low at other times as the target object rotates, also in accordance with features on the TPOS cam (or gear) attached to the target object

10

As described above, conventional TPOS detectors have the ability to differentiate a gear tooth from a gear valley (i.e., gear “features”), and to make such detection when the gear is rotating and when the gear is not rotating. In contrast, some conventional precision rotation detectors have the ability to differentiate a gear tooth from a gear valley when the gear is rotating, but not when the gear is stationary. Detectors that can identify a gear
15 tooth from a valley are sometimes referred to as “tooth detectors.” Thus, TPOS detectors are usually tooth detectors. Some precision rotation detectors can also be tooth detectors.

While detection of gear teeth can be used by some magnetic field sensors, other
20 magnetic field sensors can sense passing magnetic poles of a ring magnet (i.e., features). Thus, as used herein, the term “feature detector” is used to describe either a tooth detector or a detector of magnetic poles.

Some other conventional precision rotation detectors are unable to differentiate a
25 gear tooth from a valley (or a north pole from a south pole of a ring magnet), but instead, can differentiate an edge of a tooth of the gear from the tooth or the valley. Such detectors are sometimes referred to as “edge detectors.” Usually, TPOS detectors are not edge detectors. However, some precision rotation detectors can be edge detectors.

30 The conventional magnetic field sensor must achieve an accurate output signal that accurately differentiates between gear teeth and gear valleys even in the presence of an air gap between the magnetic field sensor and the gear that may change from installation to

installation or from time to time. Still further, the conventional magnetic field sensor must achieve these differentiations even in the presence of unit-to-unit variations in relative positions of the magnet and the magnetic field sensing element within the magnetic field sensor. Still further, the conventional magnetic field sensor must achieve these
5 differentiations even in the presence of unit-to-unit variations in the magnetic field generated by the magnet. Still further, the conventional magnetic field sensor must achieve these differentiations even in the presence of variations of an axial rotation of the magnetic field sensor relative to the gear. Still further, the conventional magnetic field sensor must achieve these differentiations even in the presence of variations of
10 temperature around the magnetic field sensor.

The above effects result in expensive design choices. In particular, some of the above effects result in use of an expensive magnet described below in conjunction with FIG. 1.

15

It would be desirable to provide a magnetic field sensor that can achieve an accurate output signal that accurately differentiates between gear teeth and gear valleys while using a simpler and less expensive magnet.

20 SUMMARY

A magnetic field sensor achieves an accurate output signal that accurately differentiates between gear teeth and gear valleys while using a simpler and less expensive magnet. The differentiation is achieved even in the presence of variations of mechanical and thermal parameters associated with the magnetic field sensor.

25

In accordance with an example useful for understanding an aspect of the present invention, a magnetic field sensor for measuring movement of a target object, the movement in an x-z plane within x-y-z Cartesian coordinates with x, y, and z orthogonal axes, a tangent to a direction of movement of a surface of the target object proximate to
30 the magnetic field sensor substantially parallel to the x axis, includes a substrate having a major planar surface within about twenty degrees of parallel to the x-z plane. The magnetic field sensor also includes a plurality of magnetic field sensing elements disposed

upon the major planar surface of the substrate. Each one of the plurality of magnetic field sensing elements has a major response axis substantially parallel to the major planar surface of the substrate. The plurality of magnetic field sensing elements is configured to generate a respective plurality of magnetic field signals.

5

In some embodiments, the above magnetic field sensor can include one or more of the following aspects in any combination.

10 In some embodiments of the above magnetic field sensor, the plurality of magnetic field sensing elements comprises a plurality of magnetoresistance elements.

In some embodiments, the above magnetic field sensor can further comprise:
an electronic circuit disposed upon the substrate and coupled to the plurality of magnetic field sensing elements, the electronic circuit comprising:

15 a non-volatile memory device operable to store a value indicative of a measured operational characteristic of the magnetic field sensor.

In some embodiments of the above magnetic field sensor, the stored value is stored during a first time period, and wherein the stored value is recalled and used during
20 a second different time period after the first time period.

In some embodiments, the above magnetic field sensor can further comprise:
an electronic circuit disposed upon the substrate and coupled to the plurality of magnetic field sensing elements, the electronic circuit comprising:

25 an output protocol module operable to use the plurality of magnetic field signals to determine a direction of movement of the target object.

In some embodiments, the above magnetic field sensor can further comprise:
a magnet disposed proximate to the substrate, the magnet having at least two poles
30 to generate a magnetic field substantially parallel to the major planar surface of the substrate.

In some embodiments of the above magnetic field sensor, the major planar surface of the substrate overlaps the target object such that a line perpendicular to the major planar surface of the substrate intersects the target object.

5 In some embodiments of the above magnetic field sensor, the target object comprises a ring magnet having a plurality of alternating north and south poles, the target object to generate a magnetic field substantially parallel to the major planar surface of the substrate.

10 In some embodiments of the above magnetic field sensor, the major planar surface of the substrate overlaps the target object such that a line perpendicular to the major planar surface of the substrate intersects the target object.

15 In some embodiments of the above magnetic field sensor, the plurality of magnetic field sensing elements is arranged in a line within about twenty degrees of parallel to the tangent to the direction of movement of the target object.

20 In some embodiments of the above magnetic field sensor, the plurality of magnetic field sensing elements comprises a quantity of magnetic field sensing elements in a range of two to nine magnetic field sensing elements.

In some embodiments of the above magnetic field sensor, the electronic circuit further comprises:

25 an output protocol module operable to use the plurality of magnetic field signals to determine a direction of movement of the target object.

In some embodiments, the above magnetic field sensor can further comprise:

a non-volatile memory device operable to store a value indicative of a measured operational characteristic of the magnetic field sensor.

30

In some embodiments of the above magnetic field sensor, the plurality of magnetic field sensing elements comprises a plurality of magnetoresistance elements.

In some embodiments of the above magnetic field sensor, maximum response axes of the plurality of magnetic field sensing elements are substantially parallel to each other.

5 In some embodiments, the above magnetic field sensor can further comprise:
an electronic circuit disposed upon the substrate and coupled to the plurality of
magnetic field sensing elements, the electronic circuit comprising:

10 a plurality of analog or digital comparators configured to compare each
respective one of the plurality of magnetic field signals to a threshold signal to
generate a plurality of binary signals, wherein states of the plurality of binary
signals are indicative of a position of the target object relative to the plurality of
magnetic field sensing elements.

In some embodiments, the above magnetic field sensor can further comprise:
15 an output protocol module operable to use the plurality of binary signals to
determine a direction of movement of the target object.

In some embodiments, the above magnetic field sensor can further comprise:
20 a non-volatile memory device operable to store a value indicative of a measured
operational characteristic of the magnetic field sensor.

In some embodiments, the above magnetic field sensor can further comprise:
an electronic circuit disposed upon the substrate and coupled to the plurality of
magnetic field sensing elements, the electronic circuit operable to determine a position of
25 the target object relative to the plurality of magnetic field sensing elements.

In some embodiments, the above magnetic field sensor can further comprise:
an electronic circuit disposed upon the substrate and coupled to the plurality of
magnetic field sensing elements, the electronic circuit comprising:
30 at least one analog-to digital converter operable to convert the plurality of
magnetic field signals to generate a plurality of binary signals, wherein states of
the plurality of binary signals are indicative of a position of the object relative to

the plurality of magnetic field sensing elements.

In some embodiments of the above magnetic field sensor, the at least one analog-to-digital converter comprises a plurality of analog-to-digital converters, each one of the
5 plurality of analog-to-digital converters coupled to a respective one of the plurality of magnetic field sensing elements.

In some embodiments, the above magnetic field sensor can further comprise:
an electronic circuit disposed upon the substrate and coupled to the plurality of
10 magnetic field sensing elements, the electronic circuit comprising:

a processor configured to compare each respective one of the plurality of magnetic field signals to a respective threshold signal to generate a plurality of binary signals, wherein states of the plurality of binary signals are indicative of a position of the target object relative to the plurality of magnetic field sensing elements.

15

In some embodiments, the above magnetic field sensor can further comprise:

a threshold calculation module coupled to receive signals representative of the plurality of magnetic field signals, the threshold calculation module configured to generate a plurality of threshold values indicative of amplitudes of the plurality of magnetic field
20 signals;

a nonvolatile memory device operable to store the plurality of threshold values;
and

a plurality of analog or digital comparators, the memory device operable to provide the plurality of threshold values as input values to the plurality of analog or digital
25 comparators.

In some embodiments of the above magnetic field sensor, the plurality of threshold values is stored during a time period when the electronic circuit is powered down and wherein the plurality of threshold values is provided to the plurality of analog or digital
30 comparators when the electronic circuit powers up.

In some embodiments of the above magnetic field sensor, the plurality of threshold

values is stored during a first time period, and wherein the plurality of threshold values is provided as the input values to the plurality of analog or digital comparators during a second different time period after the first time period.

5 In some embodiments, the above magnetic field sensor can further comprise:
 an output protocol module coupled to the processor and operable to use the
plurality of binary signals to determine a direction of movement of the target object.

 In some embodiments, the above magnetic field sensor can further comprise:
10 a non-volatile memory device coupled to the processor and operable to store a
value indicative of a measured operational characteristic of the magnetic field sensor.

 In some embodiments of the above magnetic field sensor, the plurality of magnetic
field sensing elements comprises two magnetic field sensing elements configured to
15 generate two respective magnetic field signals, the magnetic field sensor further
comprising:

 an electronic circuit disposed upon the substrate, the electronic circuit comprising:
 a differential amplifier coupled to receive a signal representative of the two
magnetic field signals and configured to generate an output signal indicative of a
20 position of the target object relative to the plurality of magnetic field sensing
elements.

 In some embodiments of the above magnetic field sensor, the plurality of magnetic
field sensing elements is formed as at least one circular vertical Hall (CVH) sensing
25 element.

 In some embodiments of the above magnetic field sensor, the plurality of magnetic
field sensing elements comprises a plurality of vertical Hall Effect elements.

30 In some embodiments of the above magnetic field sensor, the target object
comprises a ferromagnetic tooth of a gear configured to rotate.

In some embodiments of the above magnetic field sensor, the target object comprises a ferromagnetic ring magnet configured to rotate.

5 In some embodiments of the above magnetic field sensor, the plurality of magnetic field sensing elements is arranged in an arc proximate to the target object, and wherein maximum response axes of the plurality of magnetic field sensing elements are substantially parallel to each other.

10 In some embodiments of the above magnetic field sensor, the plurality of magnetic field sensing elements is arranged in an arc proximate to the target object, and wherein maximum response axes of the plurality of magnetic field sensing elements are not substantially parallel to each other.

15 In some embodiments of the above magnetic field sensor, the substrate overlaps the target object such that a line perpendicular to the major surface of the substrate intersects the target object.

In some embodiments, the above magnetic field sensor can further comprise:
20 a non-volatile memory device coupled to the plurality of magnetic field sensing elements and operable to store a value indicative of a measured operational characteristic of the magnetic field sensor.

In some embodiments of the above magnetic field sensor, the target object comprises a ferromagnetic target object.

25

In some embodiments of the above magnetic field sensor, the target object comprises a ferromagnetic gear.

In some embodiments of the above magnetic field sensor, the target object
30 comprises a ferromagnetic ring magnet.

In some embodiments of the above magnetic field sensor, the target object

comprises a non-ferromagnetic conductive target object.

In some embodiments, the above magnetic field sensor can further comprise:
an electronic circuit disposed upon the substrate and coupled to the plurality of

5 magnetic field sensing elements, the electronic circuit comprising:

a plurality of analog or digital comparators configured to compare each
respective one of the plurality of magnetic field signals to a threshold signal to
generate a plurality of binary signals, wherein states of the plurality of binary
signals are indicative of a position of the target object relative to the plurality of
10 magnetic field sensing elements.

In some embodiments, the above magnetic field sensor can further comprise:
an electronic circuit disposed upon the substrate and coupled to the plurality of
magnetic field sensing elements, the electronic circuit comprising:

15 at least one analog-to digital converter operable to convert the plurality of magnetic
field signals to generate a plurality of binary signals, wherein states of the plurality of
binary signals are indicative of a position of the object relative to the plurality of magnetic
field sensing elements.

20 BRIEF DESCRIPTION OF THE DRAWINGS

The foregoing features of the invention, as well as the invention itself may be more
fully understood from the following detailed description of the drawings, in which:

FIG. 1 is a block diagram of a prior art magnetic field sensor having a magnetic
field sensing element, an electronic circuit, and a magnet;

25 FIG. 1A is a block diagram of an example of an electronic circuit that can be used
as the electronic circuit of FIG. 1;

FIG. 2 is a block diagram of another prior art magnetic field sensor having three
magnetic field sensing elements, an electronic circuit, and a magnet;

30 FIG. 2A is a block diagram of an example of an electronic circuit that can be used
as the electronic circuit of FIG. 2;

FIG. 3 is a block diagram showing an example of a magnetic field sensor having two magnetic field sensing elements and an electronic circuit both disposed on a substrate, and also having a magnet;

FIG. 4 is a block diagram showing an example of another magnetic field sensor
5 having two magnetic field sensing elements and an electronic circuit both disposed on a substrate, and having a magnet different than the magnet of FIG. 3;

FIG. 5 is a block diagram showing an example of the two magnetic field sensing elements and an example of the electronic circuit of FIGS. 3 and 4;

FIG. 6 is a block diagram showing an example of a magnetic field sensor having a
10 plurality of magnetic field sensing elements and an electronic circuit both disposed on a substrate, and also having a magnet;

FIG. 7 is a block diagram showing an example of another magnetic field sensor having a plurality of magnetic field sensing elements and an electronic circuit both disposed on a substrate, and having a magnet different than the magnet of FIG. 3;

FIG. 8 is a block diagram showing an example of the plurality of magnetic field
15 sensing elements and an example of the electronic circuit of FIGS. 6 and 7;

FIG. 9 is a block diagram showing another example of the plurality of magnetic field sensing elements and another example of the electronic circuit of FIGS. 6 and 7;

FIG. 10 is a block diagram showing an example of a magnetic field sensor having
20 a circular vertical Hall (CVH) sensing element and an electronic circuit both disposed on a substrate, and also having a magnet;

FIG. 11 is a block diagram showing an alternate example of the two magnetic field sensing elements as compared to FIG. 5 and can be used with the electronic circuit of FIG. 5;

FIG. 12 is a block diagram showing an alternate arrangement of any of the above magnetic field sensors but for which magnetic field sensing elements contained therein overlap a sensed ferromagnetic object;

FIG. 13 is a block diagram showing an alternate arrangement of the magnetic field sensors represented in FIG. 12;

FIG. 14 is a block diagram showing an alternate arrangement of any of the above
30 magnetic field sensors but for which a sensed ferromagnetic object is a ring magnet;

FIG. 15 is a block diagram showing an alternate arrangement of the magnetic field sensors represented in FIG. 14, but for which magnetic field sensing elements contained therein overlap the ring magnet; and

FIG. 16 is a block diagram showing an alternate arrangement of magnetic field sensing elements arranged in an arc as compared to magnetic field sensing elements arranged in a line shown in FIGS. 6 and 7.

DETAILED DESCRIPTION

Before describing the present invention, some introductory concepts and terminology are explained.

As used herein, the term "magnetic field sensing element" is used to describe a variety of electronic elements that can sense a magnetic field. The magnetic field sensing element can be, but is not limited to, a Hall effect element, a magnetoresistance element, or a magnetotransistor. As is known, there are different types of Hall effect elements, for example, a planar Hall element, a vertical Hall element, and a Circular Vertical Hall (CVH) element. As is also known, there are different types of magnetoresistance elements, for example, a semiconductor magnetoresistance element such as Indium Antimonide (InSb), a giant magnetoresistance (GMR) element, for example, a spin valve, an anisotropic magnetoresistance element (AMR), a tunneling magnetoresistance (TMR) element, and a magnetic tunnel junction (MTJ). The magnetic field sensing element may be a single element or, alternatively, may include two or more magnetic field sensing elements arranged in various configurations, e.g., a half bridge or full (Wheatstone) bridge. Depending on the device type and other application requirements, the magnetic field sensing element may be a device made of a type IV semiconductor material such as Silicon (Si) or Germanium (Ge), or a type III-V semiconductor material like Gallium-Arsenide (GaAs) or an Indium compound, e.g., Indium-Antimonide (InSb).

As is known, some of the above-described magnetic field sensing elements tend to have an axis of maximum sensitivity parallel to a substrate that supports the magnetic field sensing element, and others of the above-described magnetic field sensing elements tend to have an axis of maximum sensitivity perpendicular to a substrate that supports the magnetic field sensing element. In particular, planar Hall elements tend to have axes of

sensitivity perpendicular to a substrate, while metal based or metallic magnetoresistance elements (e.g., GMR, TMR, MTJ, AMR) and vertical Hall elements tend to have axes of sensitivity parallel to a substrate.

5 As used herein, the term “magnetic field sensor” is used to describe a circuit that uses a magnetic field sensing element, generally in combination with other circuits. Magnetic field sensors are used in a variety of applications, including, but not limited to, an angle sensor that senses an angle of a direction of a magnetic field, a current sensor that senses a magnetic field generated by a current carried by a current-carrying conductor, a
10 magnetic switch that senses the proximity of a ferromagnetic object, a rotation detector that senses passing ferromagnetic articles, for example, magnetic domains of a ring magnet or a ferromagnetic target (e.g., gear teeth) where the magnetic field sensor is used in combination with a back-biased or other magnet, and a magnetic field sensor that senses a magnetic field density of a magnetic field.

15 As used herein, the term "accuracy," when referring to a magnetic field sensor, is used to refer to a variety of aspects of the magnetic field sensor. These aspects include, but are not limited to, an ability of the magnetic field sensor to differentiate: a gear tooth from a gear valley (or, more generally, the presence of a ferromagnetic object from the
20 absence of a ferromagnetic object) when the gear is not rotating and/or when the gear is rotating (or, more generally, when a ferromagnetic object is moving or not moving), an ability to differentiate an edge of a tooth of the gear from the tooth or the valley of the gear (or, more generally, the edge of a ferromagnetic object or a change in magnetization
25 direction of a hard ferromagnetic object), and a rotational accuracy with which the edge of the gear tooth is identified (or, more generally, the positional accuracy with which an edge of a ferromagnetic object or hard ferromagnetic object can be identified). Ultimately, accuracy refers to output signal edge placement accuracy and consistency with respect to gear tooth edges passing by the magnetic field sensor.

30 The terms “parallel” and “perpendicular” are used in various contexts herein. It should be understood that the terms parallel and perpendicular do not require exact perpendicularity or exact parallelism, but instead it is intended that normal manufacturing

tolerances apply, which tolerances depend upon the context in which the terms are used. In some instances, the term “substantially” is used to modify the terms “parallel” or “perpendicular.” In general, use of the term “substantially” reflects angles that are beyond manufacturing tolerances, for example, within +/- ten degrees.

5

It is desirable for magnetic field sensors to achieve a certain level or amount of accuracy even in the presence of variations in an air gap between the magnetic field sensor and the gear that may change from installation to installation or from time to time. It is also desirable for magnetic field sensors to achieve accuracy even in the presence of variations in relative positions of the magnet and the magnetic field sensing element within the magnetic field sensor. It is also desirable for magnetic field sensors to achieve accuracy even in the presence of unit-to-unit variations in the magnetic field generated by a magnet within the magnetic field sensors. It is also desirable for magnetic field sensors to achieve accuracy even in the presence of variations of an axial rotation of the magnetic field sensors relative to the gear. It is also desirable for magnetic field sensors to achieve accuracy even in the presence of temperature variations of the magnetic field sensors.

Examples below describe a particular gear (or a particular ring magnet) as may be used upon an engine camshaft target object. However, similar circuits and techniques can be used with other cams or gears or ring magnet disposed upon the engine camshaft, or upon other rotating parts of an engine, vehicle, or a machine (e.g., crank shaft, transmission gear, anti-lock braking system (ABS)), or upon rotating parts of a device that is not an engine. Other applications may include linear translation sensors or other sensors where the sensed object is not a rotating gear or ring magnet, but is a linear arrangement.

25

The gear (or target) or the ring magnet is not a part of the magnetic field sensors described below. The gear can have ferromagnetic gear teeth, which are generally soft ferromagnetic objects, but which can also be hard ferromagnetic objects, patterns, or domains which may or may not have actual physical changes in their shape.

30

Examples are shown below of magnetic field sensors that can sense ferromagnetic gear teeth having gear teeth edges upon a gear configured to rotate. Other examples are

shown below of magnetic field sensors that can sense north and south poles having pole edges upon a ring magnet configured to rotate. However, the magnetic field sensors can be used in other applications. The other applications include, but are not limited to, sensing ferromagnetic objects or poles upon a structure configured to move linearly.

5

As used herein, the term “features” is used to describe gear teeth or gear valleys upon a gear and also to describe north or south poles upon a ring magnet.

As used herein, the term “baseline” and the phrase “baseline level” are used to describe a lowest magnitude (which may be near zero or may be some other magnetic field) of a magnetic field experienced by a magnetic field sensing element within a magnetic field sensor when the magnetic field sensor is operating in a system. In some systems, this lowest magnetic field occurs when a magnetic field sensor is proximate to a gear valley as opposed to a gear tooth.

10
15

It will be understood that, in general, a difference between the baseline level and a higher level achieved, for example, when a gear tooth is proximate to a magnetic field sensor, is related to an ability of the magnetic field sensor to differentiate between a gear tooth and a valley, and thus, related to accuracy of the magnetic field sensor.

20

While it is described above that a baseline level is generated when a magnetic field sensor is proximate to a gear valley and a higher level is achieved when the magnetic field sensor is proximate to a gear tooth, other physical arrangements are also possible, for example, a reverse arrangement for which a baseline level is generated when a magnetic field sensor is proximate to a gear tooth and a higher level is achieved when the magnetic field sensor is proximate to a gear valley.

25

As used herein, the term “processor” is used to describe an electronic circuit that performs a function, an operation, or a sequence of operations. The function, operation, or sequence of operations can be hard coded into the electronic circuit or soft coded by way of instructions held in a memory device. A “processor” can perform the function, operation, or sequence of operations using digital values or using analog signals.

30

In some embodiments, the “processor” can be embodied in an application specific integrated circuit (ASIC), which can be an analog ASIC or a digital ASIC. In some embodiments, the “processor” can be embodied in a microprocessor with associated program memory. In some embodiments, the “processor” can be embodied in a discrete electronic circuit, which can be an analog or digital.

As used herein, the term “module” is used to describe a “processor.”

A processor can contain internal processors or internal modules that perform portions of the function, operation, or sequence of operations of the processor. Similarly, a module can contain internal processors or internal modules that perform portions of the function, operation, or sequence of operations of the module.

It should be understood that electronic functions that may be described below to be analog functions can instead be implemented in digital circuits, in processors, or in modules. For example, it will be recognized that a comparator can be implemented as an analog comparator that compares analog voltages, as a digital comparator that compares digital values, or as a processor or module that compares digital values. Examples shown herein to be analog examples do not limit the scope of described embodiments to be analog embodiments only.

As used herein, the term “predetermined,” when referring to a value or signal, is used to refer to a value or signal that is set, or fixed, in the factory at the time of manufacture, or by external means, e.g., programming, thereafter. As used herein, the term “determined,” when referring to a value or signal, is used to refer to a value or signal that is identified by a circuit during operation, after manufacture.

As used herein, the term “active electronic component” is used to describe and electronic component that has at least one p-n junction. A transistor, a diode, and a logic gate are examples of active electronic components. In contrast, as used herein, the term “passive electronic component” as used to describe an electronic component that does not

have at least one p-n junction. A capacitor and a resistor are examples of passive electronic components.

As used herein, the term “target object” is used to refer to a ferromagnetic gear, a
5 ferromagnetic ring magnet, a non-ferromagnetic conductive object, or another type of
target object, position or movement of which is detected by magnetic field sensor describe
herein. In some embodiments, the target object can be coupled to another object, for
example, a camshaft of an engine. Thus, the detected position or movement of the target
object can be used to identify a position or movement of the other object.

10

Referring to FIG. 1, an example of a magnetic field sensor 10 is responsive to a
gear 22 having ferromagnetic gear teeth, e.g., gear teeth 22a, 22b, 22c. It should be
recognized that the gear 22 is but one type of “ferromagnetic target object,” or simply
“target object,” which the magnetic field sensor 10 can be responsive. In other magnetic
15 systems, the ferromagnetic target object may include a permanent magnet (or a hard
ferromagnetic material), for example, the above-described ring magnet having alternating
north and south poles. Ring magnets are shown and described below in conjunction with
FIGS. 14-16.

20

The magnetic field sensor 10 includes a magnetic field sensing element 12 coupled
to an electronic circuit 16. The magnetic field sensing element 12 and the electronic
circuit 16 can be disposed upon (i.e., integrated within or upon) a substrate 14. For clarity,
here the magnetic field sensing element 12 is shown to be a Hall element with an
exaggerated size, and rotated out of the plane of the substrate 14. Furthermore, for clarity,
25 the Hall element 12 is shown to be on top of the substrate 14, but it will be appreciated
that Hall elements are usually disposed upon or within a surface of a substrate of an
integrated circuit.

30

The magnetic field sensor 10 can also include a magnet 18 (e.g. a permanent
magnet or hard ferromagnetic material). The magnet 18 is configured to generate a
magnetic field, which is generally directed along an axis 24 at the position of the magnetic
field sensing element 12, and which is subject to direction and amplitude changes

depending upon positions of the gear teeth 22a, 22b, 22c relative to the magnetic field sensor 10. However, the structure of the magnetic field at faces of the magnet 18 can be more complex due to a core 20.

5 The electronic circuit 16 is configured to generate an output signal (not shown). The output signal, when the gear is not moving, is indicative of whether the magnetic field sensor 10 is over a gear tooth or a gear valley. Thus, the magnetic field sensor 10 is sometimes referred to as a “tooth detector” (or feature detector) as opposed to an “edge detector.” The output signal, when the gear is rotating, has an edge rate or a frequency
10 indicative of a speed of rotation of the gear. Edges or transitions of states of the output signal can be used to identify positions of edges of the gear teeth as they pass by the magnetic field sensor.

 The magnet 18 can include the central core 20 comprised of a soft ferromagnetic
15 material disposed within the magnet 18. An example of a magnet with a core is described in U.S. Patent No. 6,278,269, entitled “Magnet Structure,” issued August 21, 2001, which patent is assigned to the assignee of the present invention and incorporated herein by reference in its entirety. As described in U.S. Patent No. 6,278,269, the pole configuration provided by the magnet 18 with the core 20 lowers the base field (or baseline) of a flux
20 density of the magnetic field at some points above the surface of the core 20 (e.g., to the left of the core as shown) when a valley of the gear 22 is proximate to the magnetic field sensor 10. A predetermined baseline (e.g., within a range of about +/- six hundred Gauss) at the magnetic field sensing element 12, and a resulting differential magnetic field signal 12a, 12b (i.e., an analog differential proximity signal) near zero, can be achieved with
25 proper design.

 In contrast, when a gear tooth of the gear 22 is proximate to the magnetic field sensing element 12, the magnetic field sensing element 12 experiences a higher magnetic field and generates the differential magnetic field signal 12a, 12b with a higher value. As
30 described above, a difference between the baseline magnetic field and the higher magnetic field is related to ultimate accuracy of the magnetic field sensor 10.

The baseline magnetic field, which can occur when the magnetic field sensor 10 is proximate to a valley in the gear 22, remains relatively low, with little change, even as the air gap between the gear 22 and the magnetic field sensor 10 varies. This advantageous result of low baseline substantially independent of air gap is achieved by operation of the core 20, which results in opposite magnetic poles being presented at the face of the core 20 (i.e., left side as shown) proximate to the magnetic field sensing element 12, particularly when the magnetic field sensing element 12 is proximate to a valley in the gear 22. This effect is also described in U.S. Patent Number 5,781,005, issued July 14, 1998, entitled “Hall-Effect Ferromagnetic-Article-Proximity Sensor,” which patent is assigned to the assignee of the present invention and incorporated herein by reference in its entirety.

The above-described low baseline, which occurs when the magnetic field sensor is proximate to a gear valley, results in an enhanced ability of the electronic circuit 16 to differentiate the presence of the gear tooth from a gear valley.

The above-described low baseline also provides an ability to more easily compensate for temperature effects, since the baseline magnetic field is relatively small, and therefore, circuit variations that occur due to temperature can have less influence when the magnetic field sensor 10 is proximate to a valley in the gear 22. Essentially, any error in the circuitry is able to be well corrected near the baseline magnetic field level or range, since any multiplication of the error (near zero) is smaller. Therefore, a magnetic field threshold used to distinguish a tooth from a valley can be made smaller while maintaining precision because there is less noise or error in the system over its operating conditions such as temperature, or humidity.

The magnetic field described above and provided by the magnet 18 with the core 20 results in an improved accuracy of the magnetic field sensor 10. For example, the low baseline allows the magnetic field sensing element 12 to be somewhat statically misaligned from a center of the magnet 18, as will occur due to unit-to-unit variations of mechanical alignments, without sacrificing accuracy of the magnetic field sensor 10. Accuracy is discussed above.

Referring now to FIG. 1A, an example of a prior art electronic circuit 50 can be the same as or similar to electronic circuit 16 of FIG. 1. The electronic circuit 50 can include in amplifier 54 coupled to receive a differential signal 52a, 52b, which can be the same as or similar to the differential signal 12a, 12b generated by the magnetic field sensing
5 element 12 of FIG. 1. The amplifier 54 is configured to generate an amplified signal 54a, which, in some embodiments, can split into two channels, a TPOS detector channel and a precision rotation detector channel.

In the true power on state (TPOS) channel, a TPOS detector 56 can be coupled to
10 receive the amplified signal 54a and configured to generate a TPOS output signal 56a. In some embodiments, the TPOS detector 56 can include a comparator (not shown) configured to compare the amplified signal 54a with a fixed (and trimmed) threshold. In these embodiments, the TPOS output signal 56a can be a two-state binary signal for which a high state is indicative of a gear tooth being proximate to the magnetic field sensor 10 of
15 FIG. 1 and a low state is indicative of a gear valley being proximate to the magnetic field sensor 10, or vice versa.

In the precision rotation detector channel, an automatic gain control (AGC) 58 can be coupled to receive the amplified signal 54a and configured to generate a gain controlled
20 signal 58a. A precision rotation detector 60 can be coupled to receive the gain controlled signal 58a and configured to generate a precision rotation detector output signal 60a. Like the TPOS output signal 56a, the precision rotation detector output signal 60a can be a two-state binary signal for which a high state is indicative of a gear tooth being proximate to the magnetic field sensor 10 of FIG. 1 and a low state is indicative of a gear valley being
25 proximate to the magnetic field sensor 10, or vice versa. Thus, both the TPOS detector 56 and the precision rotation detector 60 can be “tooth detectors” (i.e., “feature detectors”). However, it should be understood that the precision rotation detector channel uses the AGC 58, which, when the gear 22 is not rotating, will settle to an undesirable gain, resulting, once the gear 22 starts to rotate, in a period of time during which the gain is
30 incorrect and the precision rotation detector is not fully accurate. Even if the AGC 58 were not used, still the precision rotation detector 60 uses internal thresholds that are properly updated only when the gear 22 is rotating. However, in other embodiments, the

threshold can be supplied from outside of the electronic circuit 50.

In some embodiments, the thresholds for the TPOS detector 56 and/or for the precision rotation detector 60 are stored and later recalled and used. Storage of thresholds is described below in conjunction with FIG. 9. The same storage techniques can be used in conjunction with all of the magnetic field sensors described herein.

In some alternate embodiments, the precision rotation detector 60 can be an “edge detector,” which is unable to identify whether the magnetic field sensor 12 is proximate to a gear tooth or a gear valley, particularly when the gear is not moving, but which is able to sense edges of gear teeth as they move past the magnetic field sensor 10.

Precision rotation detectors, e.g., the precision rotation detector 60, can have a variety of configurations. Some configurations are described in the above mentioned U.S. Patent No. 6,525,531. However, other forms of precision rotation detectors are also known, including some that have two or more magnetic field sensing elements.

In general, from discussion above, it will be appreciated that the TPOS output signal 56a is indicative of whether the magnetic field sensing element 12 is proximate to a gear tooth or a gear valley, even when the gear, e.g., the gear 22 of FIG. 1, is stationary. However, since the TPOS detector 56 uses a fixed threshold, in some embodiments, having limited adjustment at power up, variations in the edge placement in the TPOS output signal 56a will occur due to a variety of factors, including, but not limited to, temperature variations, and variations in the air gap between the magnetic field sensing element 12 and the gear 22.

Unlike the TPOS detector 56, which uses fixed thresholds, the precision rotation detector 60 continually makes adjustments of thresholds to provide the precision rotation detector output signal 60a with better accuracy of edge placements of the precision rotation detector output signal 60a relative to physical positions of gear teeth. As described above, in part, it is these adjustments that make the precision rotation detector less accurate when it is first powered up or when the gear 22 first starts to rotate.

In some embodiments for which the TPOS detector 56 and the precision rotation detector 60 are integrated onto a common substrate, a multiplexer/output module 62 can be coupled to receive the TPOS output signal 56a and coupled to receive the precision rotation detector output signal 60a. Select logic 64 can provide a selection signal 64a, received by the multiplexer/output module 62. Depending upon the state of the selection signal 64a, the multiplexer/output module 62 is configured to generate an output signal 62a representative of a selected one of the TPOS output signal 56a or the precision rotation detector output signal 60a. The output signal 62a can be provided in a variety of signal formats, including, but not limited to, a SENT format, an I²C format, a PWM format, or a two-state format native to the TPOS output signal 56a and to the precision rotation detector output signal 60a.

In some examples, the select logic 64 selects the output signal 62a to be representative of the TPOS output signal 56a for a predetermined amount of time after the gear 22 starts rotating as indicated by the TPOS output signal 56a. Thereafter, the select logic 64 selects the output signal 62a to be representative of the precision rotation detector output signal 60a.

Referring now to FIG. 2, another example of a prior art magnetic field sensor 200 is responsive to a gear 214 having gear teeth, e.g., gear teeth 214a, 214b, 214c. The magnetic field sensor 200 includes three magnetic field sensing elements 202, 204, 206 coupled to an electronic circuit 210. In some embodiments, the magnetic field sensing elements 202, 204 are separated in a direction perpendicular to an axis 216 by a distance between about 1.5 millimeters and about 3.0 millimeters, and the magnetic field sensing element 206 is located midway between the magnetic field sensing elements 202, 204.

The three magnetic field sensing elements 202, 204, 206 and an electronic circuit 210 can be disposed upon (i.e., integrated within or upon) a substrate 208. For clarity, here the magnetic field sensing elements 202, 204, 206 are shown to be Hall elements with an exaggerated size, and rotated out of the plane of the substrate 208. Furthermore, for clarity, the Hall elements 202, 204, 206 are shown to be on top of the substrate 208, but it

will be appreciated that Hall elements are usually disposed upon or within a surface of a substrate of an integrated circuit.

The magnetic field sensor 200 can also include a magnet 212. The magnet 212 is
5 configured to generate a magnetic field, which is generally directed along an axis 216 at the position of the magnetic field sensing elements 202, 204, 206.

The electronic circuit 210 is configured to generate an output signal (not shown).
An exemplary electronic circuit 210 is described below in conjunction with FIG. 2A. Let
10 it suffice here to say that the electronic circuit generates differences of signals. Thus, it will be apparent that the magnetic field sensor 200 is an edge detector and not a tooth detector.

The output signal, when the gear 214 is rotating, is indicative speed of rotation of
15 the gear 214 and also indicative of positions of edges of the gear teeth. The magnetic field sensor 200 is unable to provide a TPOS function, and, when the gear 214 is stationary, is unable to identify whether the magnetic field sensing elements 202, 204, 206 are proximate to a gear tooth or a valley in the gear 214.

20 The magnet 212 can be comprised of one uniform material, and can have no central core, which is shown and described in conjunction with FIG. 1. However, in other embodiments, the magnet 212 can have a central core the same as or similar to that shown and described in conjunction with FIG. 1. In still other embodiments, the magnet 212 can have a core comprised of air or a core comprised of a non-ferromagnetic material.

25 The magnetic field sensor 200 uses the three magnetic field sensing elements 202, 204, 206 to generate a respective three differential signals 202a, 202b, and 204a, 204b, and 206a, 206b. Though the simple magnet 212 does not provide the low baseline of a magnet with a core, differences of the above differential signals result in the effect of a low
30 baseline. In essence, when the three magnetic field sensing elements 202, 204, 206 experience the same magnetic field, a differencing of the above differential signals results in a zero electronic signal.

Referring now to FIG. 2A, an example of a prior art electronic circuit 250 can be the same as or similar to electronic circuit 210 of FIG. 2. The electronic circuit 250 can include amplifiers 258, 260, 262 coupled to receive differential signals 252a, 252b, and 5 254a, 254b, and 256a, 256b, respectively. The differential signal 252a, 252b can be the same as or similar to the differential signal 202a, 202b, the differential signal 254a, 254b can be the same as or similar to the differential signals 204a, 204b, and the differential signal 256a, 256b can be the same as or similar to the differential signal 206a, 206b generated, respectively, by the magnetic field sensing elements 202, 204, 206 of FIG. 2. 10 The amplifiers 258, 260, 262 are configured to generate amplified signals 258a, 260a, 262a, respectively.

The amplified signals 258a, 260a are received by a first differencing module 264, which is configured to generate a first difference signal 264a. The amplified signals 260a, 15 262a are received by a second differencing module 266, which is configured to generate a second difference signal 266a.

The electronic circuit 250 includes two precision rotation detector channels, described above in conjunction with FIG. 1A. A AGCs 270, 276 can be the same as or 20 similar to the AGC 56 of FIG. 1A. Precisions rotation detectors 272, 278 can be the same as or similar to the precision rotation detector 60 of FIG. 1A. The precision rotation detector 272 can generate a precision rotation detector output signal 272a and the precision rotation detector 278 can generate a precision rotation detector output signal 278a. The precision rotation detector output signals 272a, 278a can be the same as or similar to the 25 precision rotation detector output signal 60a of FIG. 1A.

A speed and direction module 274 can be coupled to receive the precision rotation detector output signals 272a, 278a.

30 It should be apparent that the precision rotation detector output signals 272a, 278a are at relative phases that are determined by a direction of rotation of the gear 214. It should also be apparent that the state transition rates of the precision rotation detector

output signals 272a, 278a are representative of a speed of rotation of the gear 214.

The speed and direction module is configured to generate an output signal that can be representative of at least one of the speed of rotation or a direction of rotation of the gear 214. In some embodiments, the output signal 62a is representative of both the speed of rotation and the direction of rotation.

Referring now to FIG. 3, a magnetic field sensor 300 is responsive to a gear 322 having gear teeth, e.g., gear teeth 322a, 322b, 322c. The magnetic field sensor 300 can include two magnetic field sensing elements 304, 306 coupled to an electronic circuit 314. In some embodiments, the magnetic field sensing elements 304, 306 are separated in a direction along an axis 308 between the two magnetic field sensing elements 304, 306 by a distance between about 0.2 millimeters and about 3.0 millimeters.

In some embodiments, the two magnetoresistance elements 304, 306 have a separation between about one half and about one and one half of a width of a ferromagnetic target object feature, for example, a gear tooth of a ferromagnetic gear 322 or a magnetic domain of a ferromagnetic ring magnet. In some other embodiments, the two magnetoresistance elements 304, 306 have a separation between about one half and about twice the width of the ferromagnetic target object feature. However, in other embodiments, the separation is much smaller than half of the width, for example, one one hundredth of the width, or larger than twice the width.

The two magnetic field sensing elements 304, 306 and the electronic circuit 314 can be disposed upon a major surface 302a of (i.e., integrated within or upon) a substrate 302. For clarity, here the magnetic field sensing elements 304, 306 are shown to be magnetoresistance elements. In other embodiments, the magnetic field sensing elements 304, 306 are Hall effect elements, e.g., vertical Hall effect elements.

The magnetic field sensor 300 can also include a magnet 332. The magnet 332 is configured to generate a magnetic field, which is generally directed along an axis 308 at the position of the magnetic field sensing elements 304, 306, and is generally parallel to

the major surface 302a of the substrate 302.

The two magnetic field sensing elements 304, 306 have respective maximum response axes parallel to the major surface 302 of the substrate 302. In some
5 embodiments, the maximum response axes are parallel to each other. In some
embodiments, the maximum response axes are substantially parallel to the axis 308. In
other embodiments, the maximum response axes are substantially perpendicular to the axis
308.

10 A line perpendicular to the major surface 302a of the substrate (i.e., into the page)
and intersecting the substrate 302, also intersect the magnet 332 and does not intersect the
gear 322. Furthermore, in some embodiments, the two magnetic field sensing elements
304, 306 are disposed at positions such that an axis (e.g., 308) between (i.e., passing
through) the two magnetic field sensing elements 304, 306 does not intersect the gear 322.
15 In some embodiments, the axis (e.g., 308) between (i.e., passing through) the two
magnetic field sensing elements 304, 306 is substantially parallel to a tangent 330 to a
direction of movement, e.g., 326, of the gear 322.

In the embodiment shown, a line between north (N) and south (S) poles of the
20 magnet 332 is substantially parallel to the major surface 302a of the substrate 302, and is
substantially parallel to the axis (e.g., 308) between (i.e., passing through) the two
magnetic field sensing elements 304, 306. In some embodiments, the line between the
north and south poles of the magnet 332 does not intersect the gear 322 and is not in a
direction toward the gear 322.

25 The electronic circuit 314 is configured to generate an output signal (not shown).
An exemplary electronic circuit 314 is described below in conjunction with FIG. 5. Let it
suffice here to say that the electronic circuit 314 can generate a difference of signals in
accordance with an electronic circuit described below in conjunction with FIG. 5. Thus, it
30 will be apparent that the magnetic field sensor 300 can be an edge detector. However,
using other electronic circuits, the other electronic circuit can generate a sum of signals, in
which case, the magnetic field sensor 300 can be a tooth detector (i.e., a feature detector).

For an edge detector, the output signal, when the gear 322 is rotating, is indicative of speed of rotation of the gear 322 and also indicative of positions of edges of the gear teeth. For a tooth detector, the output signal, when the gear 322 is rotating, is indicative of speed of rotation of the gear 322 and also indicative of positions near to centers of the gear teeth or gear valleys.

While the gear 322 is shown, in other embodiments described below in conjunction with FIGS. 14 and 15, the gear 322 (and also gears described in other figures below) can be replaced by a ring magnet.

The magnet 332 can be comprised of one uniform material, and can have no central core, which is shown and described in conjunction with FIG. 1. However, in other embodiments, the magnet 332 can have a central core the same as or similar to that shown and described in conjunction with FIG. 1. In still other embodiments, the magnet 332 can have a core comprised of air or a core comprised of a non-ferromagnetic material. The core can have an axis aligned with an axis 308.

The magnetic field sensor 300 uses the two magnetic field sensing elements 304, 306 to generate a respective two magnetic field signals. Though the simple magnet 332 does not provide the low baseline of a magnet with a core, differences of the above two magnetic field signals result in an effect similar to a low baseline. In essence, when the two magnetic field sensing elements 304, 306 experience the same magnetic field (i.e., proximate to a gear tooth or a gear valley), a differencing of the above differential signals results in a zero electronic signal.

The magnetic field sensor 300 can be rotated in a direction 316 to a next position one hundred eighty degrees apart from the position shown, with no degradation of performance. However, intermediate rotations may result in a degradation of performance.

The magnetic field sensor 600 can be rotated in a direction of and arrow 318 with a

center of rotation anywhere along a line 324, through approximately +/- twenty degrees, without substantial degradation of performance.

In some embodiments, the magnetic field sensing elements, 304, 306, are
5 magneto-resistance elements. In other embodiments, the magnetic field sensing elements are Hall effect elements, e.g., vertical Hall effect elements. However, it is advantageous to use magnetic field sensing elements for which respective axes of maximum sensitivity are parallel to the axis 308.

10 Referring now to FIG. 4, in which like elements of FIG. 3 are shown having like reference designations, a magnetic field sensor 400 is like the magnetic field sensor 300 of FIG. 3. However, the magnetic field sensor 400 has a different magnet 402 for which a line between north (N) and south (S) poles of the magnet 402 is substantially parallel to the major surface 302a of the substrate 302, but substantially perpendicular to the axis
15 (e.g., 308) between (i.e., passing through) the two magnetic field sensing elements 304, 306. In some embodiments, the line between the north and south poles of the magnet 402 is in a direction toward the gear 322.

In some embodiments, the magnet 402 is a simple magnet without a core, such
20 core described above in conjunction with FIG. 1. In other embodiments, the magnet 402 has a core the same as or similar to the core 20 described above in conjunction with FIG. 1. In still other embodiments, the magnet 402 can have a core comprised of air or a core comprised of a non-ferromagnetic material. The core can be aligned with an axis along or parallel the line 324.

25 Referring now to FIG. 5, an example of an electronic circuit 500 can be the same as or similar to the electronic circuit 314 of FIGS. 3 and 4 and can be coupled to magnetic field sensing elements 502, 508 the same as or similar to the magnetic field sensing elements 304, 306 of FIGS. 3 and 4. The electronic circuit 500 can include a first
30 magneto-resistance element 502 coupled in a first half bridge with a fixed resistor 506. The electronic circuit 500 can also include a second magnetic resistance element 508 coupled in the second half bridge with a fixed resistor 504. The two half bridges can be

driven from a voltage source 506, forming a full bridge circuit.

The first half bridge generates a signal 510 responsive to an external magnetic field. The second half bridge generates a signal 512 responsive to the external magnetic
5 field.

A differential amplifier 512 can be coupled to receive the signals 510, 512 and configured to generate an amplified signal 512a. It will be understood that the amplified signal 512a is representative of a difference of signals generated by the two
10 magnetoresistance elements 502, 508.

An automatic gain control 514 can be coupled to receive the amplified signal 512a and configured to generate a gain controlled signal 514a. A precision rotation detector 516 can be coupled to receive the gain controlled signal 514a and configured to generate a
15 precision rotation detector output signal 516a. In some embodiments the precision rotation detector output signal 516a is a two state signal having high states representative, for example, of the proximity of teeth of the ferromagnetic gear, which can be the same as or similar to the ferromagnetic gear of FIGS. 3 and 4.

An output module 518 can be coupled to receive the precision rotation detector output signal 516a and configured to generate a signal 518a representative of the precision rotation detector output signal 516a with formats suitable for the application, for example, for an automotive application.
20

In some embodiments, the electronic circuit 500 can also include a memory device 520, for example, an EEPROM or nonvolatile memory device, to receive and store automatic gain control values 514a and thereafter to provide automatic gain control values 520a to control the gain of the automatic gain control 514. With this arrangement, the electronic circuit 500 can retain automatic gain control values, for example, during power
25 down, and the stored automatic gain control values 520a can be used upon power up to result in achieving a proper gain faster after power up. A similar memory device with stored automatic gain control values can be used in any of the electronic circuits described
30

below.

While the EEPROM 520 is described above to retain automatic gain control values, in other embodiments, the EEPROM 520 can retain other values, for example, threshold values, described below in conjunction with FIG. 9, or other values also indicative of measured operational characteristics of the magnetic field sensor.

Blocks of FIG. 5 can be implemented in analog circuits, digital circuits, or processors.

10

It will be recognized that, if the two magnetoresistance elements 502, 508 experience the same magnetic field, then the amplified signal 512a is not zero. Only when an edge of a gear tooth is proximate to the magnetoresistance elements 502, 508 will the amplified signal 512a not be zero. Thus, the electronic circuit 500 operates as an edge detector. Accordingly, the electronic circuit 500 does not include a true power on state channel comparable to that described above in conjunction with FIG. 1A.

15

However, in an alternate arrangement, the magnetoresistance element 506 and the resistor 502 can be interchanged in a similar electronic circuit or the magnetoresistance element 508 and the resistor 504 can be interchanged in another similar circuit to achieve a tooth detector (i.e., feature detector). The similar circuits can include a true power on state channel comparable to that described above in conjunction with FIG. 1A.

20

While two magnetoresistance elements 502, 508 are shown, in other embodiments, the magnetoresistance elements 502, 508, and the bridge circuit in which they are coupled, can be replaced with two Hall effect elements, for example, two vertical Hall effect elements.

25

Referring now to FIG. 6, a magnetic field sensor 600 is responsive to a gear 622 having gear teeth, e.g., gear teeth 622a, 622b, 622c. The magnetic field sensor 600 can include a plurality of, i.e., two or more (or more than two), magnetic field sensing elements, e.g., 604a, coupled to an electronic circuit 614. In some embodiments, the

30

magnetic field sensing elements, e.g., 604a, are separated in a direction along an axis 606 between the plurality of magnetic field sensing elements, e.g., 604a, by a distance between about 0.05 millimeters and about 2.0 millimeters.

5 The plurality of magnetic field sensing elements, e.g., 604a, and the electronic circuit 614 can be disposed upon a major surface 602a of (i.e., integrated within or upon) a substrate 602. For clarity, here the magnetic field sensing elements, e.g., 604a, are shown to be magnetoresistance elements. In other embodiments, the magnetic field sensing elements, e.g., 604a, are Hall effect elements, e.g., vertical Hall effect elements.

10

The magnetic field sensor 600 can also include a magnet 610. The magnet 610 is configured to generate a magnetic field, which is generally directed along an axis 608 at the position of the plurality of magnetic field sensing elements, e.g., 604a, and is generally parallel to the major surface 602a of the substrate 602.

15

The plurality of magnetic field sensing elements, e.g., 604a, have respective maximum response axes parallel to the major surface 602 of the substrate 602. In some embodiments, the maximum response axes are parallel to each other. In some embodiments, the maximum response axes are substantially parallel to the axis 606. In other embodiments, the maximum response axes are substantially perpendicular to the axis 606.

20

A line perpendicular to the major surface 602a of the substrate (i.e., into the page) intersects the magnet 610 and does not intersect the gear 622. Furthermore, the plurality of magnetic field sensing elements, e.g., 604a, is disposed at a position such that the axis (e.g., 606) between (i.e., passing through) the plurality of magnetic field sensing elements, e.g., 604a, does not intersect the gear 622. In some embodiments, the axis (e.g., 606) between (i.e., passing through) the plurality of magnetic field sensing elements, e.g., 604a, is substantially parallel to a tangent 630 to a direction of movement, e.g., 626, of the gear 622.

25

30

In the embodiment shown, a line between north (N) and south (S) poles of the

magnet 610 is substantially parallel to the major surface 602a of the substrate 602, and is substantially parallel to the axis (e.g., 606) between (i.e., passing through) the plurality of magnetic field sensing elements, e.g., 604a. In some embodiments, the line between north and south poles does not intersect the ferromagnetic target object 622.

5

The electronic circuit 614 is configured to generate an output signal (not shown). An example of an electronic circuit is described more fully below in conjunction with FIGS. 8 and 9. Let it suffice here to say that the electronic circuit 614 is configured to compare each one of the plurality of magnetic field signals to a threshold signal to generate a plurality of binary signals. A plurality of states of the plurality of binary signals is indicative of a position of the ferromagnetic target object 622, and, in particular, a position of an edge of a gear tooth or an edge of a gear valley, relative to the plurality of magnetic field sensing elements. Thus, it will be apparent that the magnetic field sensor 600 can operate as an edge detector, a tooth detector, or both.

10

15

The output signal, when the gear 622 is rotating, is indicative speed of rotation of the gear 622 and also indicative of positions of edges of the gear teeth. The magnetic field sensor 600 is able to provide a TPOS function, and, when the gear 622 is stationary, is able to identify whether individual ones of the plurality of magnetic field sensing elements, e.g., 604a, are proximate to a gear tooth or a valley in the gear 622.

20

Furthermore, the magnetic field sensor 600 is able to identify a direction of rotation of the gear 622 by way of a detected progression of magnetic fields sensed by the plurality of magnetic field sensing elements, e.g., 604a.

25

The magnet 610 can be comprised of one uniform material, and can have no central core, which is shown and described in conjunction with FIG. 1. However, in other embodiments, the magnet 610 can have a central core the same as or similar to that shown and described in conjunction with FIG. 1. In still other embodiments, the magnet 610 can have a core comprised of air or a core comprised of a non-ferromagnetic material. The core can be aligned parallel to the axis 606.

30

The magnetic field sensor 600 uses the plurality of magnetic field sensing elements, e.g., 604a, to generate a respective plurality of magnetic field signals.

Each respective one of the plurality of magnetic field signals is responsive to a
5 magnetic field generated by the magnet 602 and influenced by a position of a
ferromagnetic target object, e.g., gear teeth 622a, 622b, 622c, relative to a position of each
respective one of the plurality of magnetic field sensing elements. The ferromagnetic
target object 622 is configured to move in a direction 626 of movement. The plurality of
magnetic field sensing elements, e.g., 604a, is disposed along the axis 606, which is
10 substantially parallel to the tangent 630.

In some alternate embodiments, the plurality of magnetic field sensing elements,
e.g., 604as, is disposed along an arc rather than along the line 606. A diameter of the arc
can be the same as or similar to a diameter of the gear 622. The arc can be curved in the
15 same direction as the circumference of the gear, or in the other direction. When disposed
in an arc, maximum response axes of the magnetic field sensing elements can be parallel
to each other, or they may not be parallel to each other. This arrangement is shown below
in conjunction with FIG. 16.

20 In some embodiments, the plurality of magnetic field sensing elements, e.g., 604a,
has a respective plurality of maximum response axes parallel to each other. In some
embodiments, the maximum response axes are substantially parallel to the axis 606. In
other embodiments, the maximum response axes are substantially perpendicular to the axis
606.

25 The magnetic field sensor 600 can be rotated in a direction 616 to a next position
one hundred eighty degrees apart from the position shown, with no degradation of
performance. However, intermediate rotations may result in a degradation of
performance.

30 The magnetic field sensor 600 can be rotated in a direction of and arrow 618 with a
center of rotation anywhere along a line 624, through approximately +/- twenty degrees,

without substantial degradation of performance.

In some embodiments, the magnetic field sensing elements, e.g., 604a, are magnetoresistance elements. In other embodiments, the magnetic field sensing elements are Hall effect elements, e.g., vertical Hall effect elements. However, it is advantageous to use magnetic field sensing elements for which respective axes of maximum sensitivity are parallel to the axis 606.

Referring now to FIG. 7, in which like elements of FIG. 6 are shown having like reference designations, a magnetic field sensor 700 is like the magnetic field sensor 600 of FIG. 6. However, the magnetic field sensor 700 has a different magnet 702 for which a line between north (N) and south (S) poles of the magnet 702 is substantially parallel to the major surface 602a of the substrate 602, and substantially perpendicular to the axis (e.g., 606) between (i.e., passing through) the plurality of magnetic field sensing elements, e.g., 604a, . In some embodiments, the line between the north and south poles of the magnet 702 is in a direction toward the gear 622 and intersects the gear 622.

Referring now to FIG. 8, an electronic circuit 800 can be the same as or similar to electronic circuit 614 of FIGS. 6 and 7 and coupled to a plurality of magnetoresistance elements, which can be the same as or similar to the plurality of magnetic field sensing elements, e.g., 604a, of FIGS. 6 and 7.

The electronic circuit 800 can include a plurality of electronic channels, of which a channel having a magnetoresistance element 802 and a fixed resistor 804 is but one example. The plurality of electronic channels can be coupled to receive a voltage from a voltage regulator 806. Taking the magnetoresistance element 802 and the fixed resistor 804, which form a voltage divider, as being representative of elements of other ones of the electronic channels, a voltage signal 808 can be generated at the junction between the magnetoresistance element 802 and a fixed resistor 804. The voltage signal 808 has a value representative of a magnitude of the magnetic field experienced by the magnetoresistance element 802. Other ones of the electronic channels generate voltage signals having values representative of magnetic fields experienced by other ones of the

magnetoresistance elements.

In some embodiments, a quantity of the magnetoresistance elements can be in the range of two to nine.

5

In other embodiments, the voltage source can be replaced with a current source or with separate current sources to drive each resistor divider, e.g., 802, 804. In some embodiments, the separate current sources can be separate controlled legs of current mirrors, each having the same reference leg.

10

The voltage signal 808 is received by an amplifier 810. The amplifier 810 is configured to generate an amplified voltage signal 810a. A comparator 812 is coupled to receive the amplified voltage signal 810a, coupled to receive a threshold signal 818, and configured to generate a comparison signal 812a (i.e., a binary, two-state, signal).

15

In some other embodiments, the amplifiers, e.g., 810, are not used.

A nonvolatile memory device, for example, an electrically erasable read only memory (EEPROM) 814, is coupled to receive a plurality of such comparison signals at a multi-bit address input. The EEPROM 814 produces an output signal 814a, which can be a single bit output signal or a multi-bit output signal. The output signal 814a can have a value, i.e., a digital value, representative of a position of a gear tooth relative to the plurality of magnetoresistance elements, for example, a position of the gear tooth 322b of FIG. 6 relative to a position of the plurality of magnetic field sensing elements shown in FIG. 6. Thus, one or more states of the signal 814a are representative of an edge of the gear tooth 622b being proximate to the plurality of magnetic field sensing elements.

20

25

It will be appreciated that the EEPROM 814 can act as a look-up table, and can provide any desired mapping of address to output signal 814a. The same electronic circuit can be applied to both the magnetic field sensor 600 of FIG. 6 and to the magnetic field sensor 700 of FIG. 7, but perhaps with different look up tables stored in the EEPROM 814.

30

The signal 814a can be indicative of a speed of rotation and/or a direction of rotation of the ferromagnetic target object, e.g., 622 of FIG. 6.

5 In some other embodiments, the EEPROM 814 is replaced by a processor.

In some embodiments, the output signal 814a is received by an output protocol module 816. The output protocol module 816 is configured to generate a formatted signal 816a in a selected one of a plurality of formats including, but not limited to, a SENT
10 format, an I2C format, a PWM format, or a binary format.

The formatted signal 816a can also be indicative of a speed of rotation and/or a direction of rotation of the ferromagnetic target object, e.g., 622 of FIG. 6. To this end, the output protocol module 816 can use the signal 814a to identify the speed of rotation
15 and/or the direction of rotation of the ferromagnetic target object. Certain digital values of the signal 814a may be indicative of a center of a ferromagnetic target feature (e.g., gear tooth) being proximate to the plurality of magnetoresistance elements, certain other digital values of the signal 814a may be indicative of a particular edge of a ferromagnetic target
20 object feature being proximate to the plurality of magnetoresistance elements, and certain other digital values of the signal 814a may be indicative of a different particular edge of a ferromagnetic target object feature being proximate to the plurality of magnetoresistance elements.

While the electronic circuit 800 is shown to have a plurality of simple voltage
25 dividers, e.g., a voltage divider formed from the magnetoresistance element 802 with the fixed resistor 804, in other embodiments, each channel can use a different arrangement, for example, a Wheatstone (full) bridge.

In still other embodiments, each one of the electronic channels can use a respective
30 Hall effect element, e.g., a respective vertical Hall effect element. As is known, a Hall element can receive, i.e., can be driven by, either a voltage source or a current source, and the Hall effect element can generate, from two output signal nodes, a differential output

signal. It should be apparent how the electronic circuit 800 can be modified to use Hall effect elements instead of magnetoresistance elements.

While a plurality of comparators (e.g., 812) is shown, in other embodiments, there
5 can be one or more comparators that are multiplexed to provide parallel channels.
Similarly, while a plurality of amplifiers 810 is shown, in other embodiments, one or more
amplifiers can be multiplexed to provide the parallel channels.

Referring now to FIG. 9, in which like elements of FIG. 8 are shown having like
10 reference designations, an electronic circuit 900 can be the same as or similar to electronic
circuit 614 of FIGS. 6 and 7, and coupled to a plurality of magnetoresistance elements,
which can be the same as or similar to the plurality of magnetic field sensing elements,
e.g., 604a, of FIGS. 6 and 7.

15 The electronic circuit 900 can include a plurality of electronic channels, of which
a channel having the magnetoresistance element 802 and a fixed resistor 804 is but one
example. Taking this channel as being representative of other ones of a plurality of
channels, an analog-to-digital converter (ADC) 912 can be coupled to receive the
amplified voltage signal 810a and configured to generate a converted signal 902a.

20 A position calculation module 904 (i.e., a processor) can be coupled to receive the
converted signal 902a. In particular, a digital comparator 906 within the position
calculation module 904 can be coupled to receive the converted signal 902a. The digital
comparator 906 can also be coupled to receive a digital threshold value 905 and
25 configured to generate a comparison signal 906a.

In some embodiments, a nonvolatile memory device, for example, an EEPROM
908, can be coupled to receive the comparison signal 906a along with other comparison
signals. The EEPROM 908 can include a lookup table 909 to receive the comparison
30 signals and to generate a signal 908a, which can be a single bit signal or a multi-bit signal.
The signal 908a can be the same as or similar to the signal 814a of FIG. 8.

The signal 908a can be indicative of a speed of rotation and/or a direction of rotation of the ferromagnetic target object, e.g., 622 of FIG. 6.

5 An output protocol module 910 can receive the signal 908a and can generate a formatted signal 910a, which can be the same as or similar to the formatted signal 816a of FIG. 8.

10 The formatted signal 910a can be indicative of a speed of rotation and/or a direction of rotation of the ferromagnetic target object, e.g., 622 of FIG. 6. To this end, the output protocol module 910 can use the signal 908a to identify the speed of rotation and/or the direction of rotation of the ferromagnetic target object. Certain digital values of the signal 908a may be indicative of a center of a ferromagnetic target feature (e.g., gear tooth) being proximate to the plurality of magnetoresistance elements, certain other digital values of the signal 908a may be indicative of a particular edge of a ferromagnetic target
15 object feature being proximate to the plurality of magnetoresistance elements, and certain other digital values of the signal 908a may be indicative of a different particular edge of a ferromagnetic target object feature being proximate to the plurality of magnetoresistance elements.

20 In some embodiments, the position calculation module 904 can also include a threshold calculation module 912 coupled to receive one or more of the converted signals 903.

In operation, the threshold calculation module 912 can identify desired threshold
25 values, e.g., 905, to use as inputs to the digital comparators, e.g., 906. For example, in some embodiments, the threshold calculation module 912 can calculate positive and negative peak values of the converted signals 903, can compute peak-to-peak values, and can compute respective threshold values to be desired percentages of the peak-to-peak values. For example, in some embodiments, calculated thresholds can be approximately
30 60 percent and approximately forty percent of the peak-to-peak values. Accordingly, the position calculation module 904 can store in a threshold storage region 911 of the EEPROM 906, the calculated threshold values, and can supply the calculated threshold

values from the threshold storage area 911 to the digital comparators, e.g., 906.

With the above arrangement, after a power down to the electronic circuit 900, upon powering up again, the stored threshold values can be rapidly used, resulting in a faster power up response time.

While separate analog-to-digital converters are shown on each channel, in other embodiments, there can be one or more analog-to digital converters coupled to the amplifiers, e.g., 810, through a multiplexer (not shown). Similarly, while a plurality of comparators is shown, in other embodiments, there can be one or more comparators coupled to the one or more analog-to-digital converters and coupled to the processor 908 through a multiplexer (not shown..

While the EEPROM 908 is shown to be within the position calculation module 904, in other embodiments, the EEPROM 908 is outside of the position calculation module 904.

Some other embodiments are a combination of parts of FIGS. 8 and 9. For example, in some other embodiments, the analog-to-digital converters, e.g., 902, are not used, in which case, the plurality of comparators, e.g., 906 can be, for example, analog comparators that provide the comparison signals, e.g., 906, as binary signals to the position calculation module 904. Accordingly, the EEPROM 908 (or the threshold calculation module 912), through one or more digital-to-analog converters (DACs, not shown), can provide analog threshold signals to the comparators.

In still other embodiments, the threshold calculation module 912 can be an analog module operable to identify positive and negative peaks of the amplified signals, e.g., 810a, operable to provide associated thresholds between the positive and negative peaks, and operable to provide the thresholds to the comparators, e.g., 906, as analog thresholds. This arrangement can be the same as or similar to parts of the precision rotation detectors described above in conjunction with FIG. 1A, for which reference is made above to prior art patents and patent applications.

Referring now to FIG. 10, a magnetic field sensor 1000 is responsive to a gear 1022 having gear teeth, e.g., gear teeth 1022a, 1022b, 1022c. The magnetic field sensor 1000 can include a CVH sensing element 1004 having a plurality of vertical Hall effect
5 elements coupled to an electronic circuit 1014. In some embodiments, a diameter of the CVH sensing element 1004 is between about 0.1 millimeters and about 1.0 millimeters.

The CVH sensing element 1004 and the electronic circuit 1014 can be disposed upon a major surface 1002a of (i.e., integrated within or upon) a substrate 1002.

10

The magnetic field sensor 1000 can also include a magnet 1010. The magnet 1010 is configured to generate a magnetic field, which is generally directed along an axis 1024 at the position of the CVH sensing element 1004 and is generally parallel to the major surface 1002a of the substrate 1002.

15

The vertical Hall effect sensing elements within the CVH sensing element 1004 have respective maximum response axes parallel to the major surface 1002 of the substrate 1002.

20

A line perpendicular to the major surface 1002a of the substrate (i.e., into the page) intersects the magnet 1010 and does not intersect the gear 1022.

25

In the embodiment shown, a line between north (N) and south (S) poles of the magnet 1010 is substantially parallel to the major surface 1002a of the substrate 1002. In some embodiments, the line between the north and south poles of the magnet 1010 intersects the gear 1022 and is in a direction toward the gear 1022. In some other embodiments, the line between the north and south poles of the magnet 1010 is substantially parallel to the line 1006 and does not intersect the gear 1022.

30

The electronic circuit 1014 is configured to generate an output signal (not shown). Let it suffice here to say that the electronic circuit 1014 is configured to generate an x-z angle signal having x-z angle values representative of an angle (i.e., direction) of a

magnetic field experienced by the CVH sensing element 1004. Thus, it will be apparent that the magnetic field sensor 1000 can operate as an edge detector or as a tooth detector.

5 The output signal, when the gear 1022 is rotating, is indicative of a speed of rotation of the gear 1022 and also indicative of positions of edges of the gear teeth and also positions of the gear teeth. The magnetic field sensor 1000 is able to provide a TPOS function, and, when the gear 1022 is stationary, is able to identify whether the CVH sensing element 1004 is proximate to a gear tooth or a valley in the gear 1022.

10 The magnet 1010 can be comprised of one uniform material, and can have no central core, which is shown and described in conjunction with FIG. 1. However, in other embodiments, the magnet 1010 can have a central core the same as or similar to that shown and described in conjunction with FIG. 1. In still other embodiments, the magnet 1010 can have a core comprised of air or a core comprised of a non-ferromagnetic
15 material. In some embodiments, the central core can have an axis substantially parallel to an axis 1024.

The magnetic field sensor 1000 uses the CVH sensing element 1004 to generate one sequential magnetic field signal.

20

The sequential magnetic field signal is responsive to a magnetic field generated by the magnet 1010 and influenced by a position of a ferromagnetic target object, e.g., gear teeth 1022a, 1022b, 1022c, relative to a position of each respective one of the plurality of magnetic field sensing elements. The ferromagnetic target object 1022 is configured to
25 move in a direction 1026 of movement. A tangent 1030 to the direction of movement 1026 is shown.

The magnetic field sensor 1000 can be rotated in a direction 1016 to a next position one hundred eighty degrees apart from the position shown, with no degradation of
30 performance. However, intermediate rotations may result in a degradation of performance.

The magnetic field sensor 1000 can be rotated in a direction of and arrow 1018 with a center of rotation anywhere along a line 1024, through approximately +/- twenty degrees, without substantial degradation of performance.

5 In some alternate embodiments, the CVH sensing element 1004 is replaced by a plurality of separately isolated vertical Hall effect elements.

In some alternate arrangements, there can be two or more CVH sensing elements disposed upon the substrate, substantially along the axis 1006.

10

Full operation of the CVH sensing element 1004 and the electronic circuit 1014 of FIG. 10 is described in more detail in PCT Patent Application No. PCT/EP2008/056517, entitled "Magnetic Field Sensor for Measuring Direction of a Magnetic Field in a Plane," filed May 28, 2008, which is published in the English language as PCT Publication No.
15 WO 2008/145610.

15

Referring now to FIG. 11, the two magnetic field sensing elements of FIGS. 3, 4, and 5, shown to be two magnetoresistance elements coupled in a bridge arrangement in FIG. 5, can instead be separately magnetoresistance elements coupled to respective current
20 sources. It should be apparent how the two magnetoresistance elements of FIG. 15 can be coupled to the electronic circuit of FIG. 5. It should be noted that a signal, $-V_2$, is inverted relative to a signal, V_2 , shown in FIG. 5, and thus must be inverted to couple as the signal, V_2 , in FIG. 5 to achieve the same functionality described as an edge detector in FIG. 5.

25

Referring now to FIG. 12, a magnetic field sensor 1200 can be the same as or similar to the magnetic field sensor 300 of FIG. 3, the magnetic field sensor 600 of FIG. 6, or the magnetic field sensor 1000 of FIG. 10 (but with the magnet rotated ninety degrees). A block 1204 is representative of the magnetic field sensing elements 304, 306 of FIG. 3,
30 the plurality of magnetic field sensing elements, e.g., 604a, of FIG. 6, or the CVH sensing element 1004 of FIG. 10. A block 1214 is representative of the electronic circuit 314 of FIG. 3, the electronic circuit 614 of FIG. 6, or the electronic circuit 1014 of FIG. 10.

30

The block 1204 representative of magnetic field sensing elements is disposed on a surface 1202a of a substrate 1202. The magnetic field sensor 1200 can include a magnet 1232 disposed as shown behind the substrate 1202 such that a line perpendicular to the substrate 1202 intersects the magnet 1232. North and south poles of the magnet 1232 can be arranged as shown to be like the alignment of magnets 332, 610 FIGS. 3 and 6, respectively, or like the magnet 1010 of FIG. 10, but rotated ninety degrees.

Unlike the magnetic field sensors shown above, here the substrate 1202 and the block 1204 representative of magnetic field sensing elements overlap a ferromagnetic target object 1222. The ferromagnetic target object 1222 is shown here to be a ferromagnetic gear having gear teeth, e.g., 1222a, 1222b, 1222c. In another embodiment the magnet 1232 and ferromagnetic target object 1222 can be replaced by a ring magnet or permanent magnet (hard ferromagnetic material) as described below in conjunction with FIGS. 14 and 15.

The magnetic field sensor 1200 can be rotated in a direction 1212 to a next position one hundred eighty degrees apart from the position shown, with no degradation of performance. However, intermediate rotations may result in a degradation of performance or may not be possible due to contact with the ferromagnetic target object 1222.

The magnetic field sensor 1200 can be rotated in a direction of and arrow 1216 with a center of rotation anywhere along a line 1224, through approximately +/- twenty degrees, without substantial degradation of performance.

Referring now to FIG. 13, in which like elements of FIG. 12 are shown having like reference designations, a magnetic field sensor 1300 is like the magnetic field sensor 1200 of FIG. 12. However, unlike the magnetic field sensor 1200 of FIG. 12, the magnetic field sensor 1300 includes a magnet 1302 having north and south poles arranged as shown, perpendicular to the north and south pole arrangement of the magnet 1232 of FIG. 12.

All magnetic field sensors shown and described above are shown to sense a

movement of ferromagnetic target object in the form of a gear or cam. However, FIGS. 14 and 15 described below show the same or similar magnetic field sensors for sensing movement of a ring magnet. Comments made above about edge detectors, tooth detectors, and TPOS functions apply in the same way when sensing a ring magnet.

5

Referring now to FIG. 14, in which like elements of FIG. 12 are shown having like reference designations, a magnetic field sensor 1400 is like the magnetic field sensors described above. However, the magnetic field sensor 1400 has no internal magnet. Instead, the magnetic field sensor 1400 is responsive to passing magnetic domains of a ring magnet 1402. N and S designations shown can be indicative of north and south poles associated with the ring magnet target. A S or N pole would exist on the other side of the page if magnetized perpendicular to the page. In other embodiments the N and S would be on the outer radial dimension toward the ring magnet while a complimentary S or N would exist on the inner radial side of the ring magnet.

10
15

In some embodiments, the magnetic domains of the ring magnet 1402 are magnetized parallel to the page. In some other embodiments, the magnetic domains of the ring magnet 1402 are magnetized perpendicular to the page.

20

Referring now to FIG. 15, in which like elements of FIG. 14 are shown having like reference designations, a magnetic field sensor 1500 is like the magnetic field sensors described above. However, the magnetic field sensor 1500 has no internal magnet. Instead, the magnetic field sensor 1500 is responsive to passing magnetic domains of the ring magnet 1402.

25

Unlike the magnetic field sensor 1400 of FIG. 14, the substrate 1202 overlaps the ring magnet 1402 such that a line perpendicular to the substrate 1202 intersects the ring magnet 1402. In other embodiments, more of the substrate 1202, or the entire substrate 1202, overlaps the ring magnet 1402.

30

Referring now to FIG. 16, a plurality of magnetic field sensing elements, e.g., 1602a, can be used as the plurality of magnetic field sensing elements, e.g., 604a, of the

magnetic field sensors 600, 700 of FIGS. 6 and 7. However, unlike the plurality of magnetic field sensing elements, e.g., 604a, of the magnetic field sensors 600, 700 of FIGS. 6 and 7, the magnetic field sensing elements, e.g., 1602a, can be disposed in an arc 1600. In some embodiments, a radius of curvature of the arc 1600 can be the same as a
5 radius of curvature of a ring magnet 1604 (or alternatively, a gear) to which the magnetic field sensing elements, e.g., 1602a, are responsive. However, other radii of curvatures are also possible.

In some alternate arrangements represented, for example, by the magnetic field
10 sensor 1500 of FIG. 15, the magnetic field sensing elements, e.g., 1602a, can be disposed over and overlap the ring magnet 1604.

In some embodiments, maximum response axes of the plurality of magnetic field sensing elements, e.g., 1602a, are parallel to each other.
15

In some embodiments, maximum response axes of the plurality of magnetic field sensing elements, e.g., 1602a, are not parallel to each other.

In some other embodiments, the plurality of magnetic field sensing elements is
20 arranged in a straight line, which is not parallel to a tangent to the ring magnet 1604, i.e., which is at a diagonal to the ring magnet 1604.

While ferromagnetic target objects in the form of ferromagnetic gears and ferromagnetic ring magnets are described above, in other embodiments, any of the
25 ferromagnetic target objects can be replaced by a non-ferromagnetic target object. In these embodiments, the non-ferromagnetic target object can be an electrically conductive target object in which eddy currents can be generated by rotation of the non-ferromagnetic conductive target object in the presence of a magnetic field, which may be supplied by a magnet the same as or similar to the magnets 332, 610 of FIGS. 3 and 6, respectively, or
30 the same as or similar to the magnet 1010 of FIG. 10. In other embodiments, a coil or an electromagnet may provide the magnetic field. The above-described magnetic field sensing elements can be responsive to magnetic fields generated by the eddy currents in

the non-ferromagnetic conductive target objects. Arrangements responsive to eddy currents are described, for example, in U.S. Patent Application number 13/946,417, filed July 19, 2013, and entitled "Methods And Apparatus For Magnetic Sensor Having An Integrated Coil Or Magnet To Detect A Non-Ferromagnetic Target," which supplication is
5 assigned to the assignee of the present application, and which application is incorporated by reference herein in its entirety.

From the above, it will be understood that the target object sensed with magnetic field sensors described herein can be a ferromagnetic target object (e.g., a gear of a ring
10 magnet) or a non-ferromagnetic conductive object (e.g., a gear).

Magnetic field sensors described above use a sensed positon of the sensed object to identify speed and/or direction of rotation.

15 All references cited herein are hereby incorporated herein by reference in their entirety.

Having described preferred embodiments, which serve to illustrate various concepts, structures and techniques, which are the subject of this patent, it will now
20 become apparent that other embodiments incorporating these concepts, structures and techniques may be used. Accordingly, it is submitted that the scope of the patent should not be limited to the described embodiments but rather should be limited only by the spirit and scope of the following claims.

25

CLAIMS

1. A magnetic field sensor for measuring movement of a target object, the movement in an x-z plane within x-y-z Cartesian coordinates with x, y, and z orthogonal axes, a
5 tangent to a direction of movement of a surface of the target object proximate to the magnetic field sensor substantially parallel to the x axis, the magnetic field sensor comprising:
- a substrate having a major planar surface within about twenty degrees of parallel to the x-z plane; and
 - 10 a plurality of magnetic field sensing elements disposed upon the major planar surface of the substrate, each one of the plurality of magnetic field sensing elements having a major response axis substantially parallel to the major planar surface of the substrate, and the plurality of magnetic field sensing elements is configured to generate a respective plurality of magnetic field signals.
- 15
2. The magnetic field sensor of Claim 1, wherein the plurality of magnetic field sensing elements comprises a plurality of magnetoresistance elements.
3. The magnetic field sensor of Claim 1, further comprising:
- 20 an electronic circuit disposed upon the substrate and coupled to the plurality of magnetic field sensing elements, the electronic circuit comprising:
- a non-volatile memory device operable to store a value indicative of a measured operational characteristic of the magnetic field sensor.
- 25
4. The magnetic field sensor of Claim 3, wherein the stored value is stored during a first time period, and wherein the stored value is recalled and used during a second different time period after the first time period.
5. The magnetic field sensor of Claim 1, further comprising:
- 30 an electronic circuit disposed upon the substrate and coupled to the plurality of magnetic field sensing elements, the electronic circuit comprising:
- an output protocol module operable to use the plurality of magnetic field signals to

determine a direction of movement of the target object.

6. The magnetic field sensor of Claim 1, further comprising:

5 a magnet disposed proximate to the substrate, the magnet having at least two poles to generate a magnetic field substantially parallel to the major planar surface of the substrate.

7. The magnetic field sensor of Claim 6, wherein the major planar surface of the substrate overlaps the target object such that a line perpendicular to the major planar surface of the substrate intersects the target object.

10

8. The magnetic field sensor of Claim 1, wherein the target object comprises a ring magnet having a plurality of alternating north and south poles, the target object to generate a magnetic field substantially parallel to the major planar surface of the substrate.

15

9. The magnetic field sensor of Claim 8, wherein the major planar surface of the substrate overlaps the target object such that a line perpendicular to the major planar surface of the substrate intersects the target object.

20

10. The magnetic field sensor of Claim 1, wherein the plurality of magnetic field sensing elements is arranged in a line within about twenty degrees of parallel to the tangent to the direction of movement of the target object.

11. The magnetic field sensor of Claim 10, wherein the plurality of magnetic field sensing elements comprises a quantity of magnetic field sensing elements in a range of two to nine magnetic field sensing elements.

25

12. The magnetic field sensor of Claim 10, wherein the electronic circuit further comprises:

30

an output protocol module operable to use the plurality of magnetic field signals to determine a direction of movement of the target object.

13. The magnetic field sensor of Claim 10, further comprising:
a non-volatile memory device operable to store a value indicative of a measured operational characteristic of the magnetic field sensor.
- 5 14. The magnetic field sensor of Claim 10, wherein the plurality of magnetic field sensing elements comprises a plurality of magnetoresistance elements.
15. The magnetic field sensor of Claim 10, wherein maximum response axes of the plurality of magnetic field sensing elements are substantially parallel to each other.
- 10 16. The magnetic field sensor of Claim 10, further comprising:
an electronic circuit disposed upon the substrate and coupled to the plurality of magnetic field sensing elements, the electronic circuit comprising:
a plurality of analog or digital comparators configured to compare each
15 respective one of the plurality of magnetic field signals to a threshold signal to generate a plurality of binary signals, wherein states of the plurality of binary signals are indicative of a position of the target object relative to the plurality of magnetic field sensing elements.
- 20 17. The magnetic field sensor of Claim 16, wherein the electronic circuit further comprises:
an output protocol module operable to use the plurality of binary signals to determine a direction of movement of the target object.
- 25 18. The magnetic field sensor of Claim 16, wherein the electronic circuit further comprises:
a non-volatile memory device operable to store a value indicative of a measured operational characteristic of the magnetic field sensor.
- 30 19. The magnetic field sensor of Claim 10, further comprising:
an electronic circuit disposed upon the substrate and coupled to the plurality of magnetic field sensing elements, the electronic circuit operable to determine a position of

the target object relative to the plurality of magnetic field sensing elements.

20. The magnetic field sensor of Claim 10, further comprising:

an electronic circuit disposed upon the substrate and coupled to the plurality of
5 magnetic field sensing elements, the electronic circuit comprising:

at least one analog-to digital converter operable to convert the plurality of
magnetic field signals to generate a plurality of binary signals, wherein states of
the plurality of binary signals are indicative of a position of the object relative to
the plurality of magnetic field sensing elements.

10

21. The magnetic field sensor of Claim 20, wherein the at least one analog-to-digital
converter comprises a plurality of analog-to-digital converters, each one of the plurality of
analog-to-digital converters coupled to a respective one of the plurality of magnetic field
sensing elements.

15

22. The magnetic field sensor of Claim 10, further comprising:

an electronic circuit disposed upon the substrate and coupled to the plurality of
magnetic field sensing elements, the electronic circuit comprising:

a processor configured to compare each respective one of the plurality of magnetic
20 field signals to a respective threshold signal to generate a plurality of binary signals,
wherein states of the plurality of binary signals are indicative of a position of the target
object relative to the plurality of magnetic field sensing elements.

23. The magnetic field sensor of Claim 22, wherein the electronic circuit further
25 comprises:

a threshold calculation module coupled to receive signals representative of the
plurality of magnetic field signals, the threshold calculation module configured to generate
a plurality of threshold values indicative of amplitudes of the plurality of magnetic field
signals;

30 a nonvolatile memory device operable to store the plurality of threshold values;

and

a plurality of analog or digital comparators, the memory device operable to provide

the plurality of threshold values as input values to the plurality of analog or digital comparators.

24. The magnetic field sensor of Claim 23, wherein the plurality of threshold values is
5 stored during a time period when the electronic circuit is powered down and wherein the
plurality of threshold values is provided to the plurality of analog or digital comparators
when the electronic circuit powers up.

25. The magnetic field sensor of Claim 23, wherein the plurality of threshold values is
10 stored during a first time period, and wherein the plurality of threshold values is provided
as the input values to the plurality of analog or digital comparators during a second
different time period after the first time period.

26. The magnetic field sensor of Claim 22, wherein the electronic circuit further
15 comprises:
an output protocol module coupled to the processor and operable to use the
plurality of binary signals to determine a direction of movement of the target object.

27. The magnetic field sensor of Claim 22, further comprising:
20 a non-volatile memory device coupled to the processor and operable to store a
value indicative of a measured operational characteristic of the magnetic field sensor.

28. The magnetic field sensor of Claim 6, wherein the plurality of magnetic field
sensing elements comprises two magnetic field sensing elements configured to generate
25 two respective magnetic field signals, the magnetic field sensor further comprising:
an electronic circuit disposed upon the substrate, the electronic circuit comprising:
a differential amplifier coupled to receive a signal representative of the two
magnetic field signals and configured to generate an output signal indicative of a
position of the target object relative to the plurality of magnetic field sensing
30 elements.

29. The magnetic field sensor of Claim 1, wherein the plurality of magnetic field

sensing elements is formed as at least one circular vertical Hall (CVH) sensing element.

30. The magnetic field sensor of Claim 1, wherein the plurality of magnetic field sensing elements comprises a plurality of vertical Hall Effect elements.

5

31. The magnetic field sensor of Claim 1, wherein the target object comprises a ferromagnetic tooth of a gear configured to rotate.

10 32. The magnetic field sensor of Claim 1, wherein the target object comprises a ferromagnetic ring magnet configured to rotate.

15 33. The magnetic field sensor of Claim 1, wherein the plurality of magnetic field sensing elements is arranged in an arc proximate to the target object, and wherein maximum response axes of the plurality of magnetic field sensing elements are substantially parallel to each other.

20 34. The magnetic field sensor of Claim 1, wherein the plurality of magnetic field sensing elements is arranged in an arc proximate to the target object, and wherein maximum response axes of the plurality of magnetic field sensing elements are not substantially parallel to each other.

25 35. The magnetic field sensor of Claim 1, wherein the substrate overlaps the target object such that a line perpendicular to the major surface of the substrate intersects the target object.

25

36. The magnetic field sensor of Claim 1, further comprising:
a non-volatile memory device coupled to the plurality of magnetic field sensing elements and operable to store a value indicative of a measured operational characteristic of the magnetic field sensor.

30

37. The magnetic field sensor of Claim 1, wherein the target object comprises a ferromagnetic target object.

38. The magnetic field sensor of Claim 1, wherein the target object comprises a ferromagnetic gear.

5 39. The magnetic field sensor of Claim 1, wherein the target object comprises a ferromagnetic ring magnet.

40. The magnetic field sensor of Claim 1, wherein the target object comprises a non-ferromagnetic conductive target object.

10

41. The magnetic field sensor of Claim 1, further comprising:
an electronic circuit disposed upon the substrate and coupled to the plurality of magnetic field sensing elements, the electronic circuit comprising:

15

a plurality of analog or digital comparators configured to compare each respective one of the plurality of magnetic field signals to a threshold signal to generate a plurality of binary signals, wherein states of the plurality of binary signals are indicative of a position of the target object relative to the plurality of magnetic field sensing elements.

20

42. The magnetic field sensor of Claim 1, further comprising:
an electronic circuit disposed upon the substrate and coupled to the plurality of magnetic field sensing elements, the electronic circuit comprising:

25

at least one analog-to digital converter operable to convert the plurality of magnetic field signals to generate a plurality of binary signals, wherein states of the plurality of binary signals are indicative of a position of the object relative to the plurality of magnetic field sensing elements.

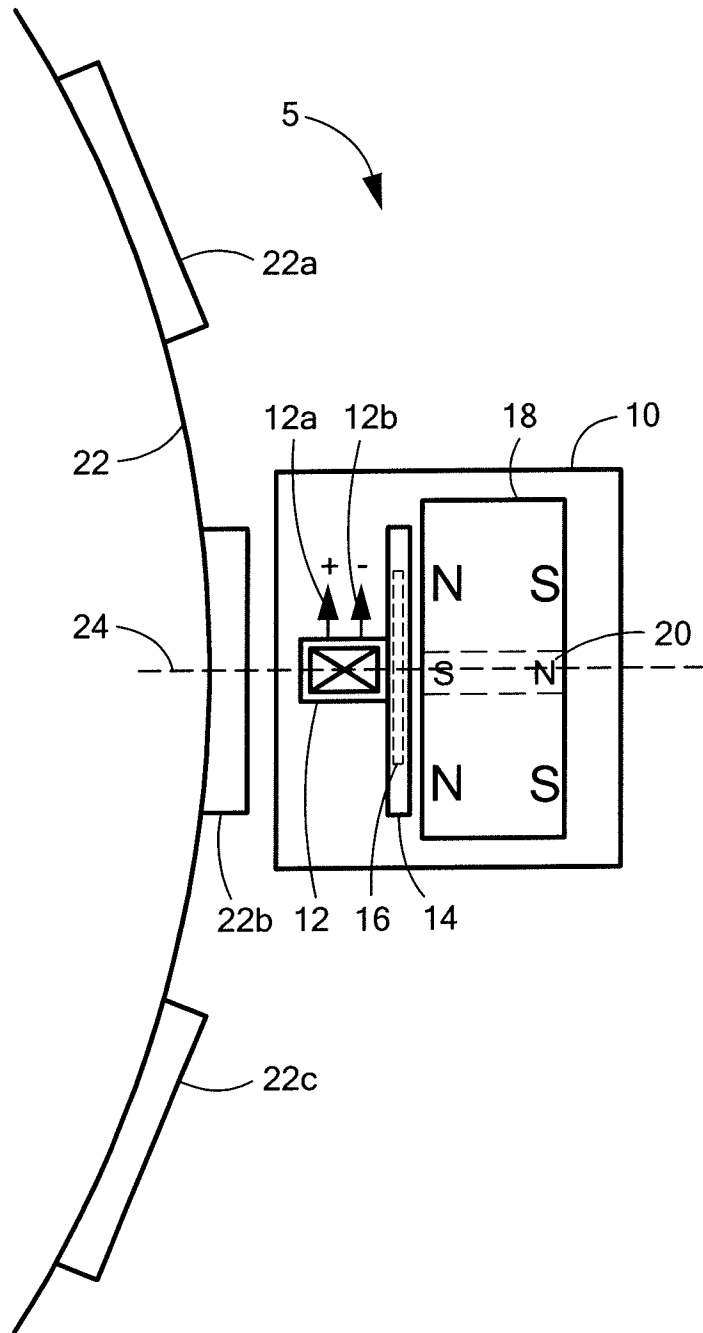

FIG. 1
PRIOR ART

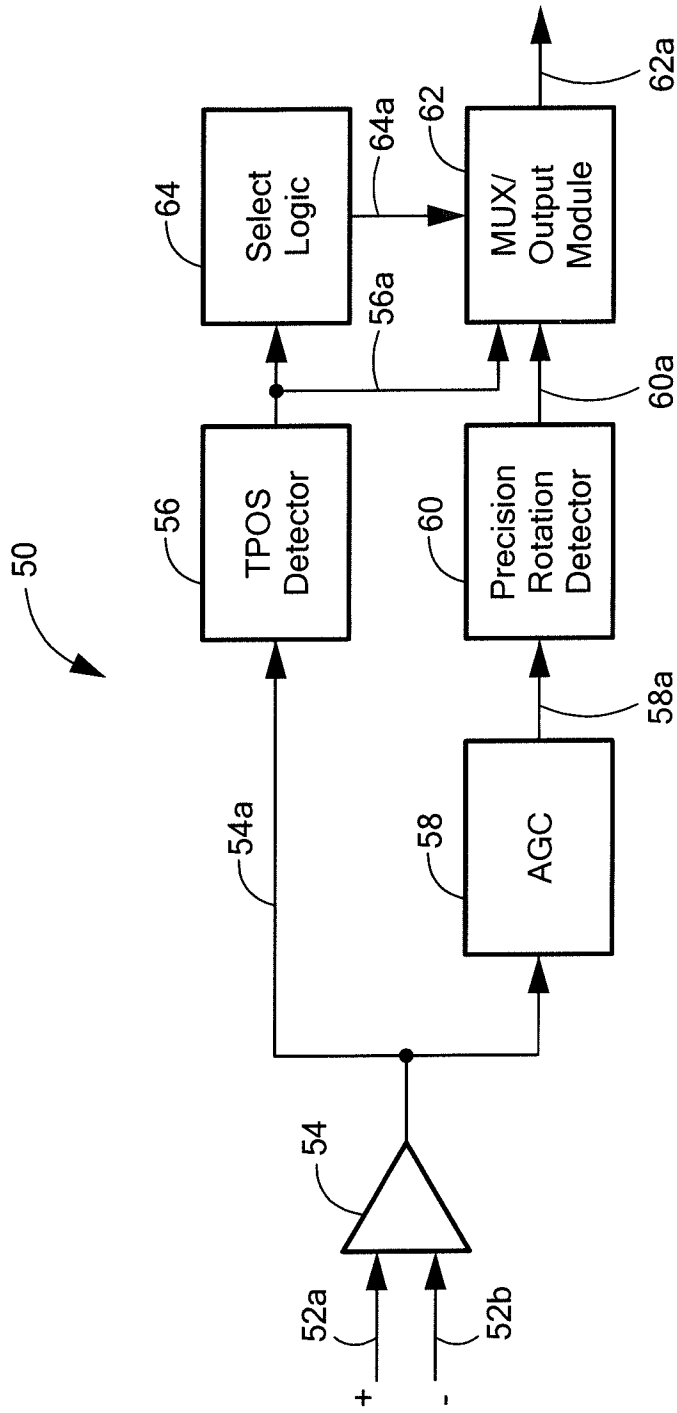

FIG. 1A
PRIOR ART

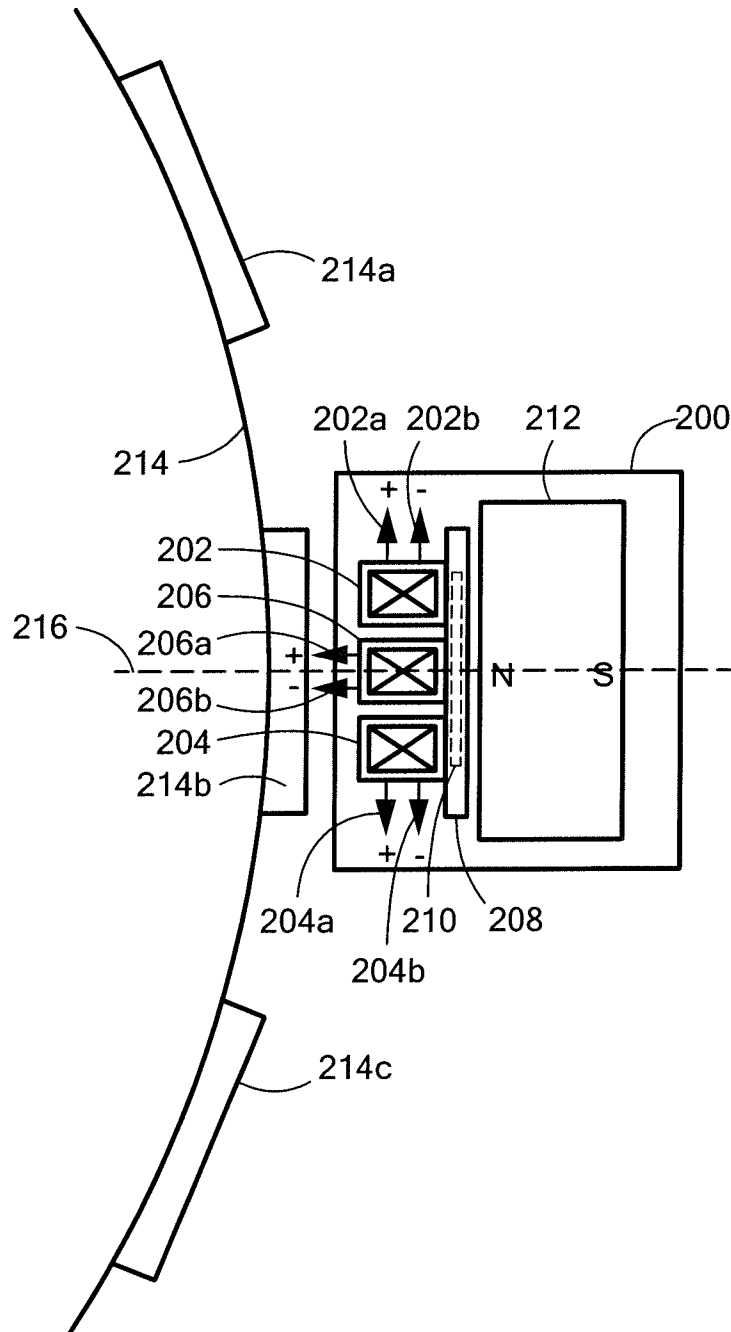

FIG. 2
PRIOR ART

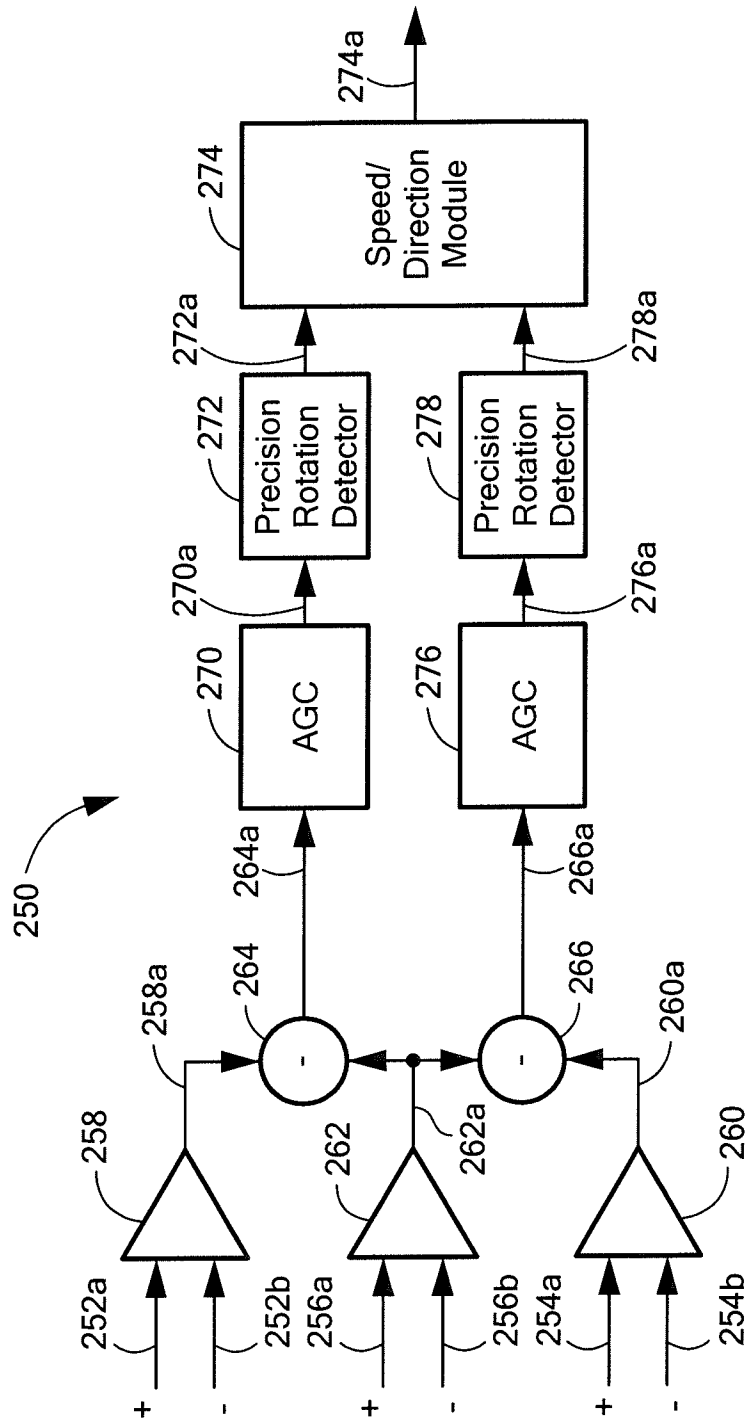

FIG. 2A
PRIOR ART

5/18

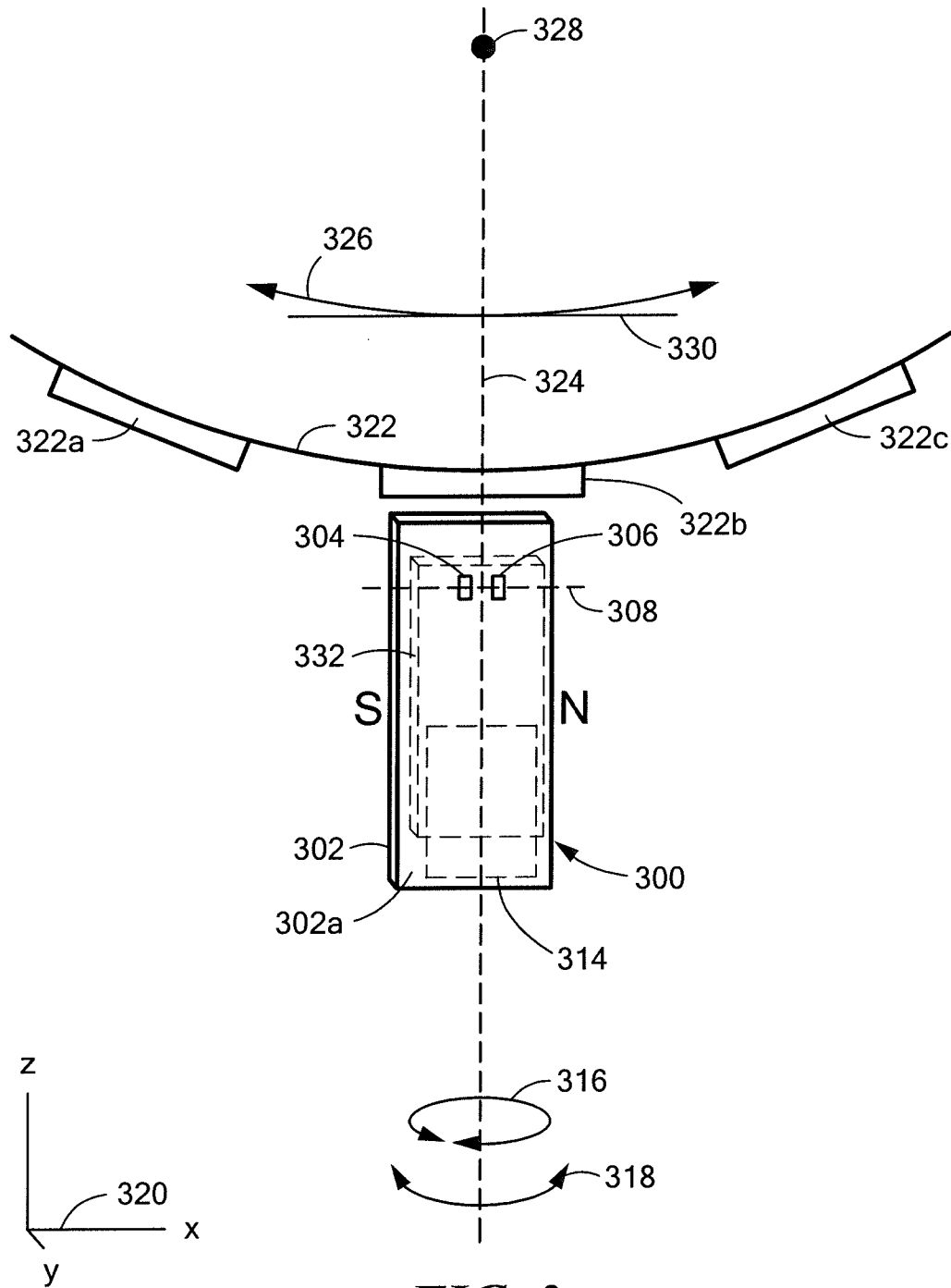

FIG. 3

6/18

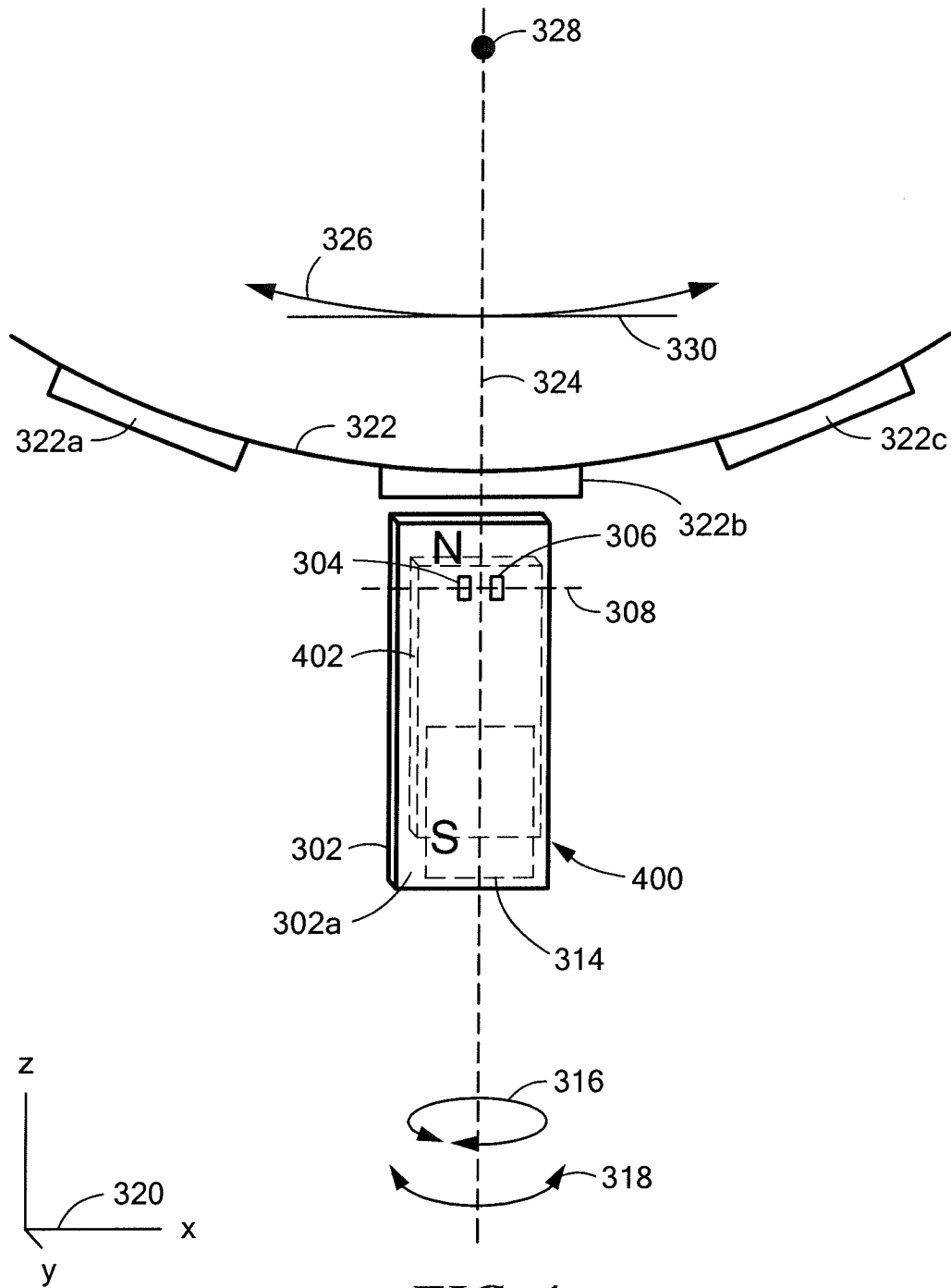

FIG. 4

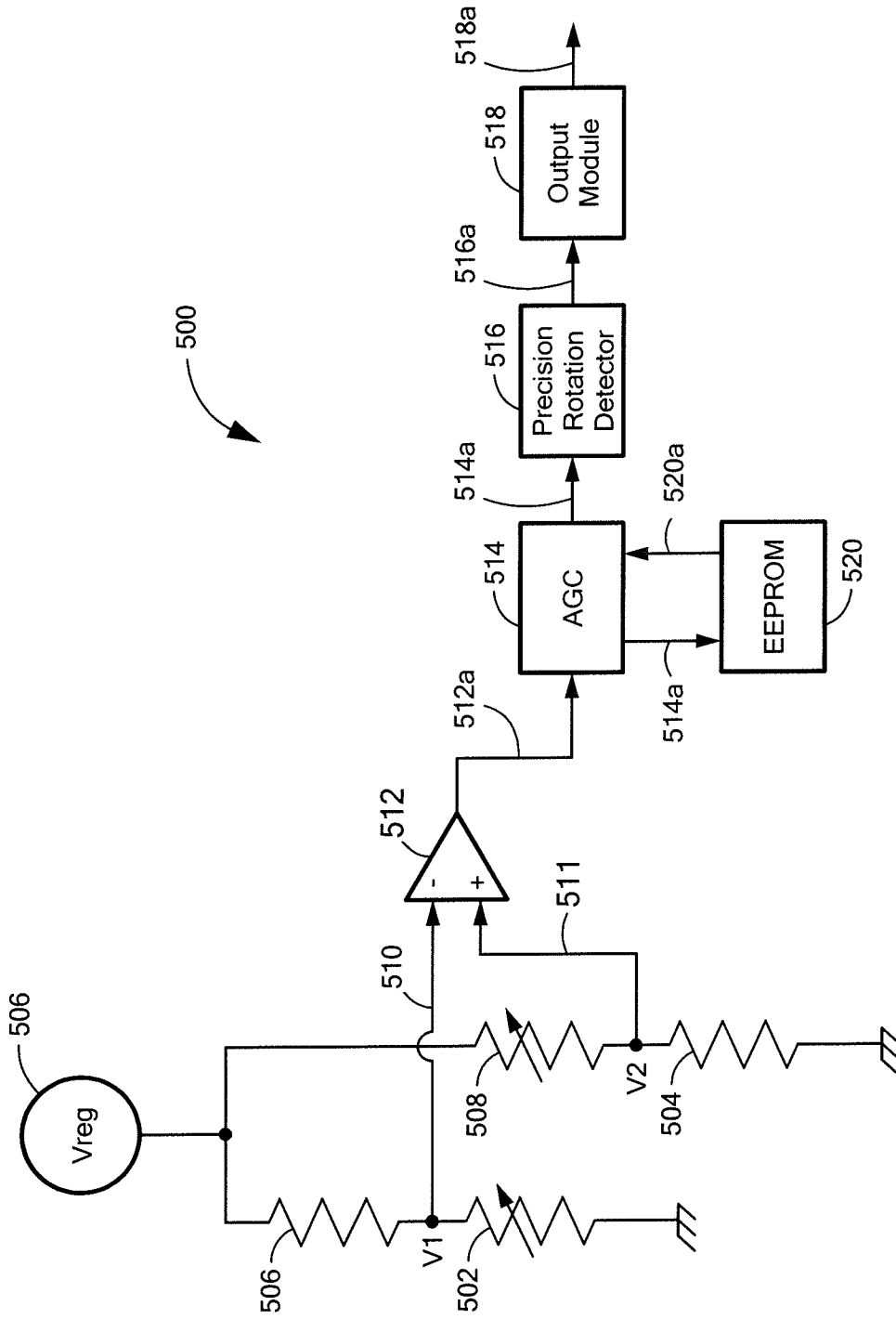

FIG. 5

8/18

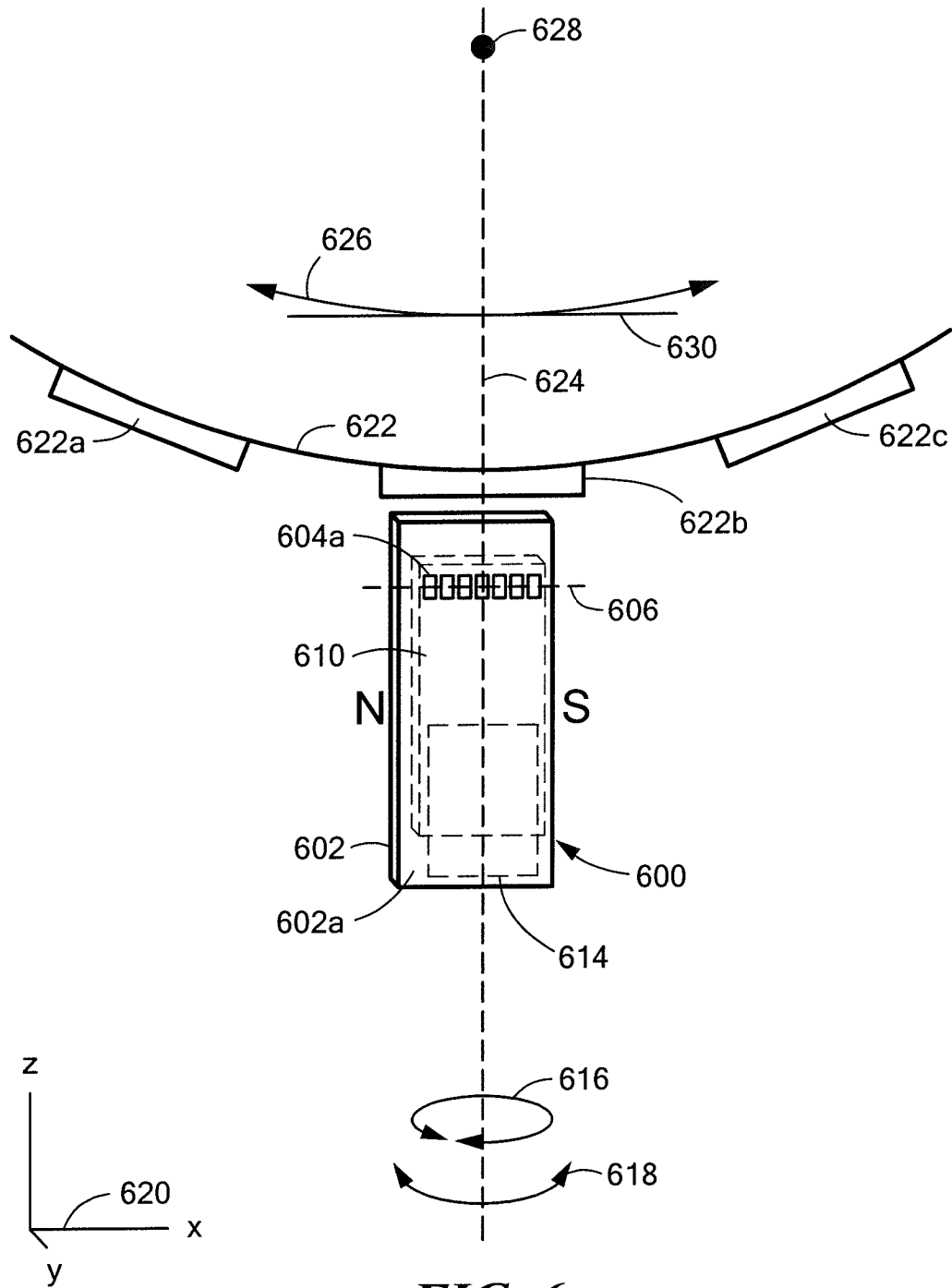

FIG. 6

9/18

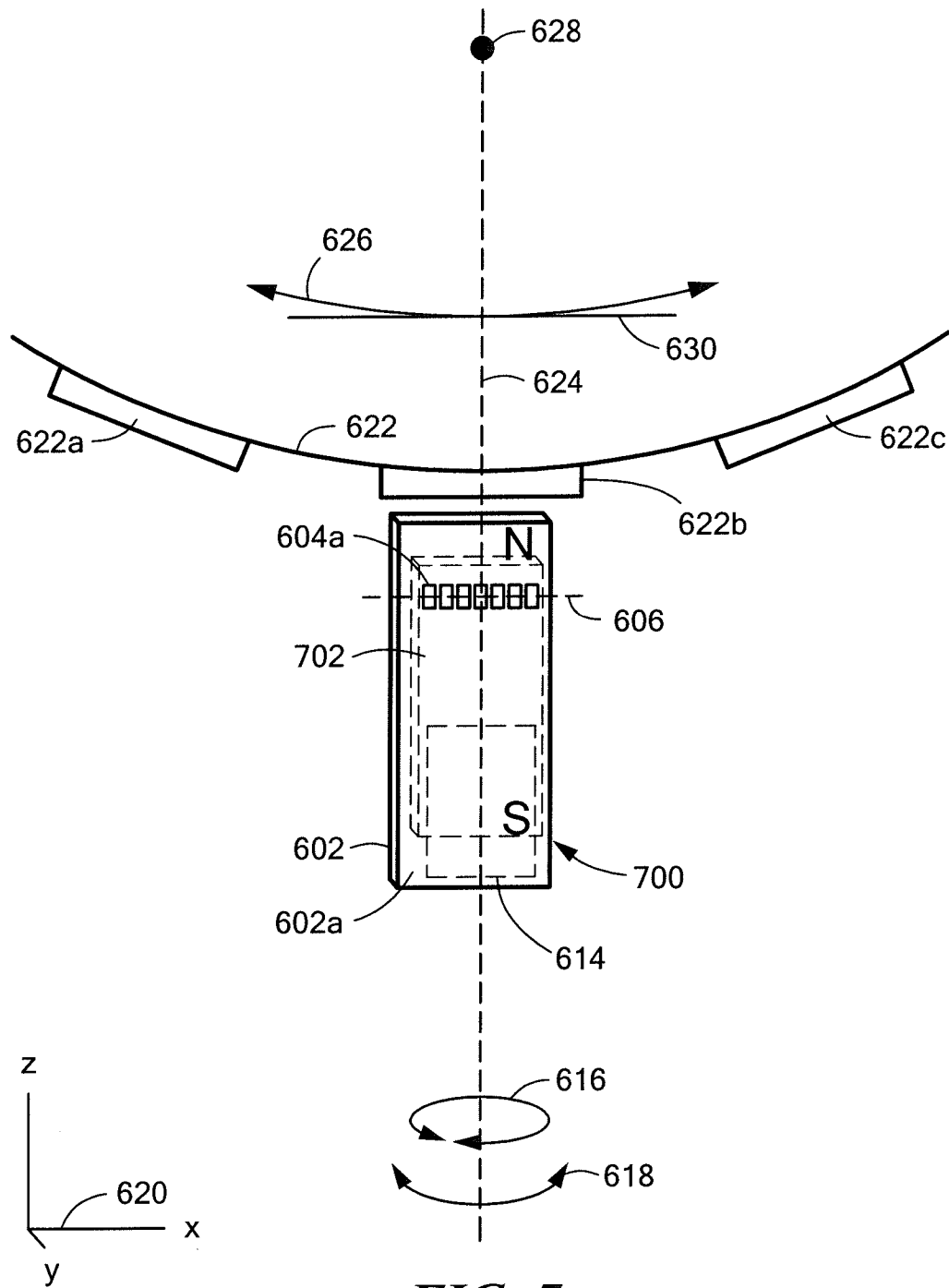

FIG. 7

10/18

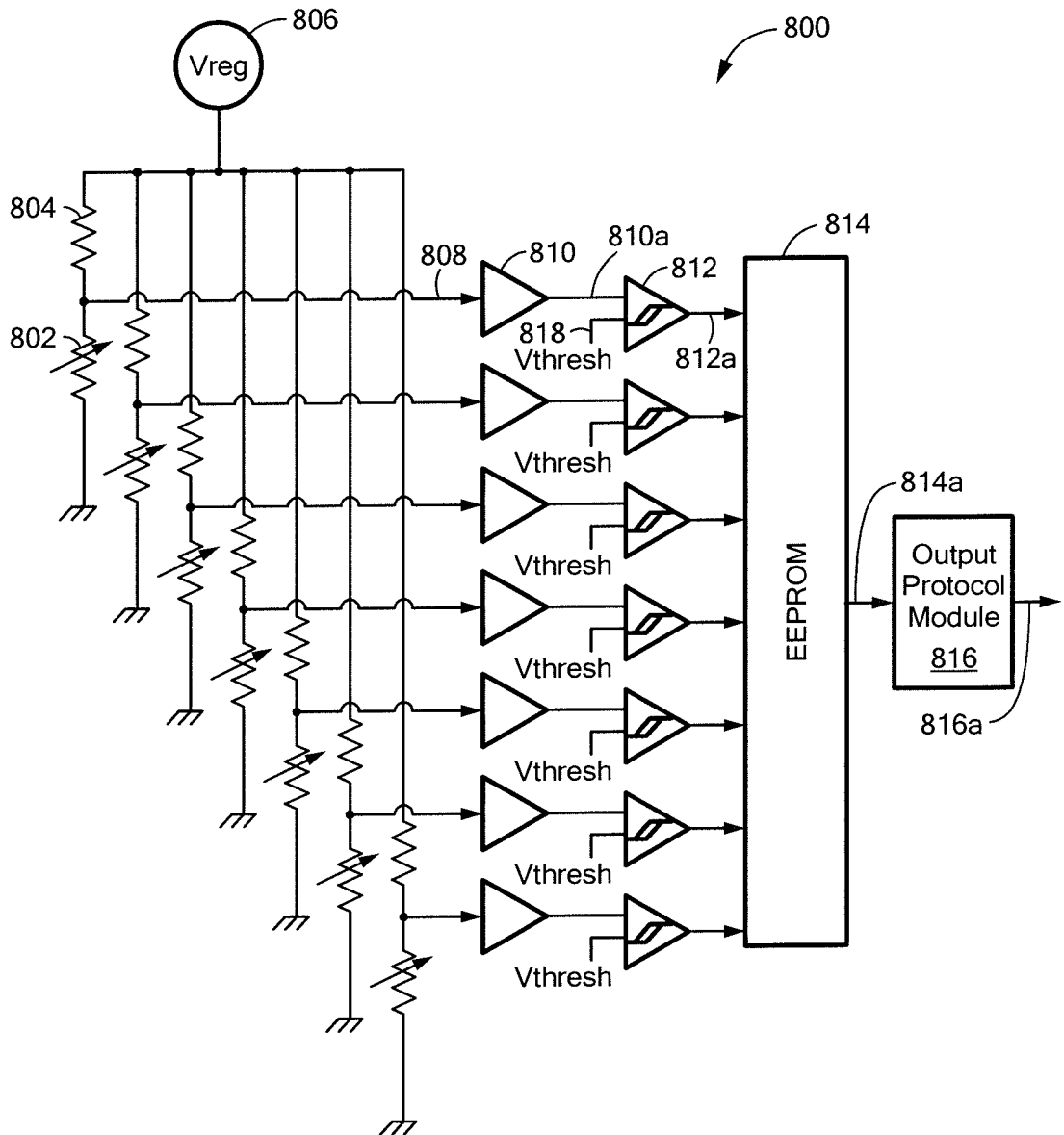

FIG. 8

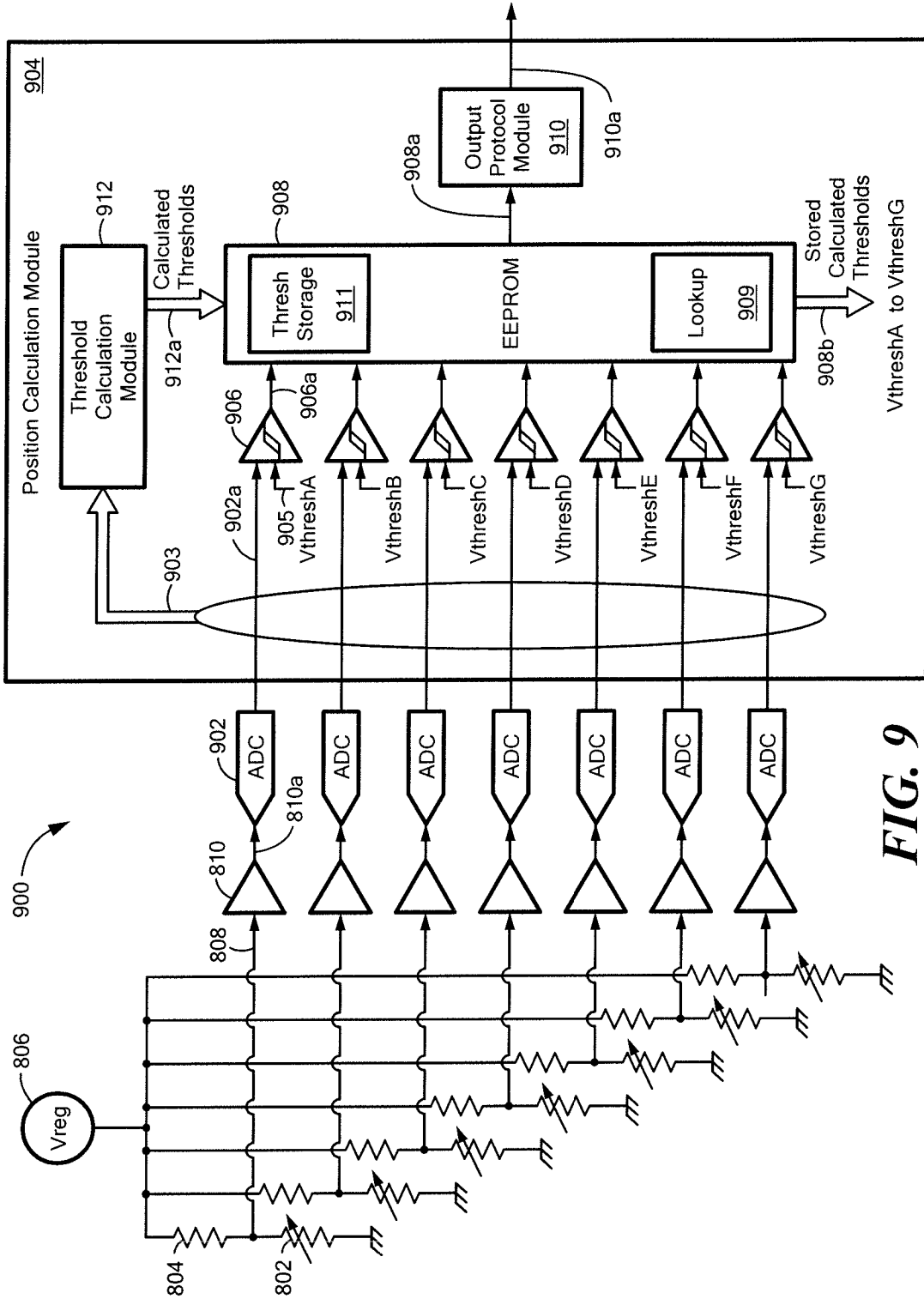

FIG. 9

12/18

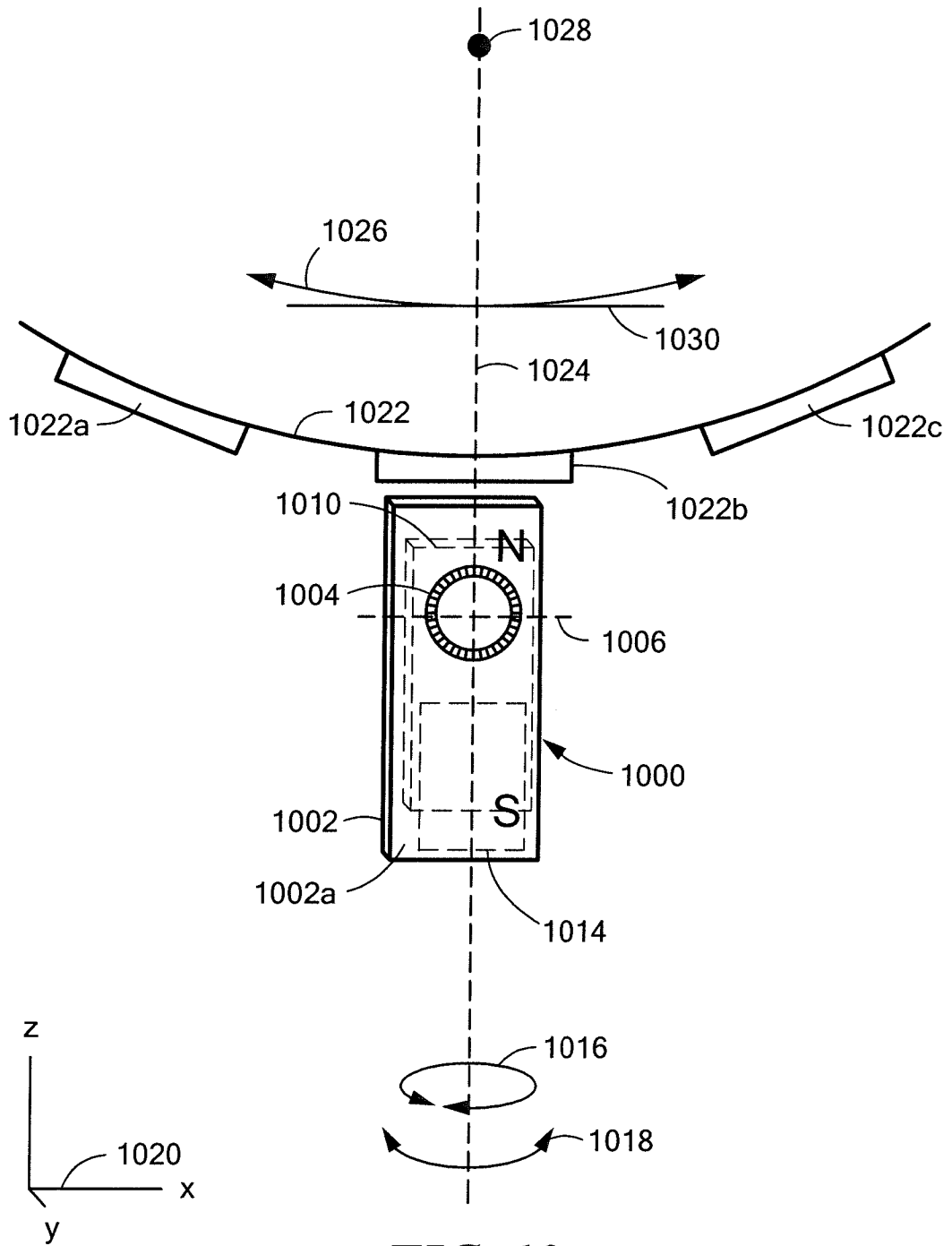

FIG. 10

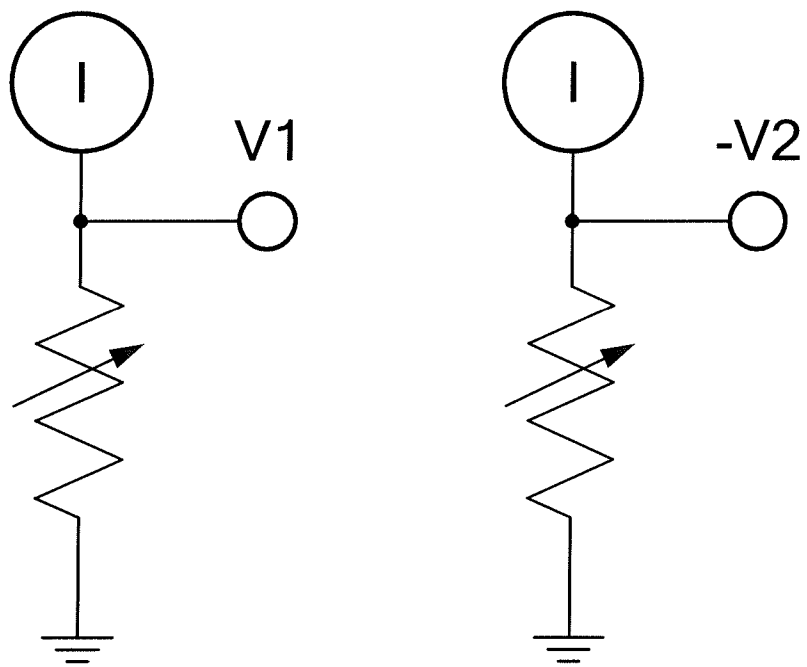

FIG. 11

14/18

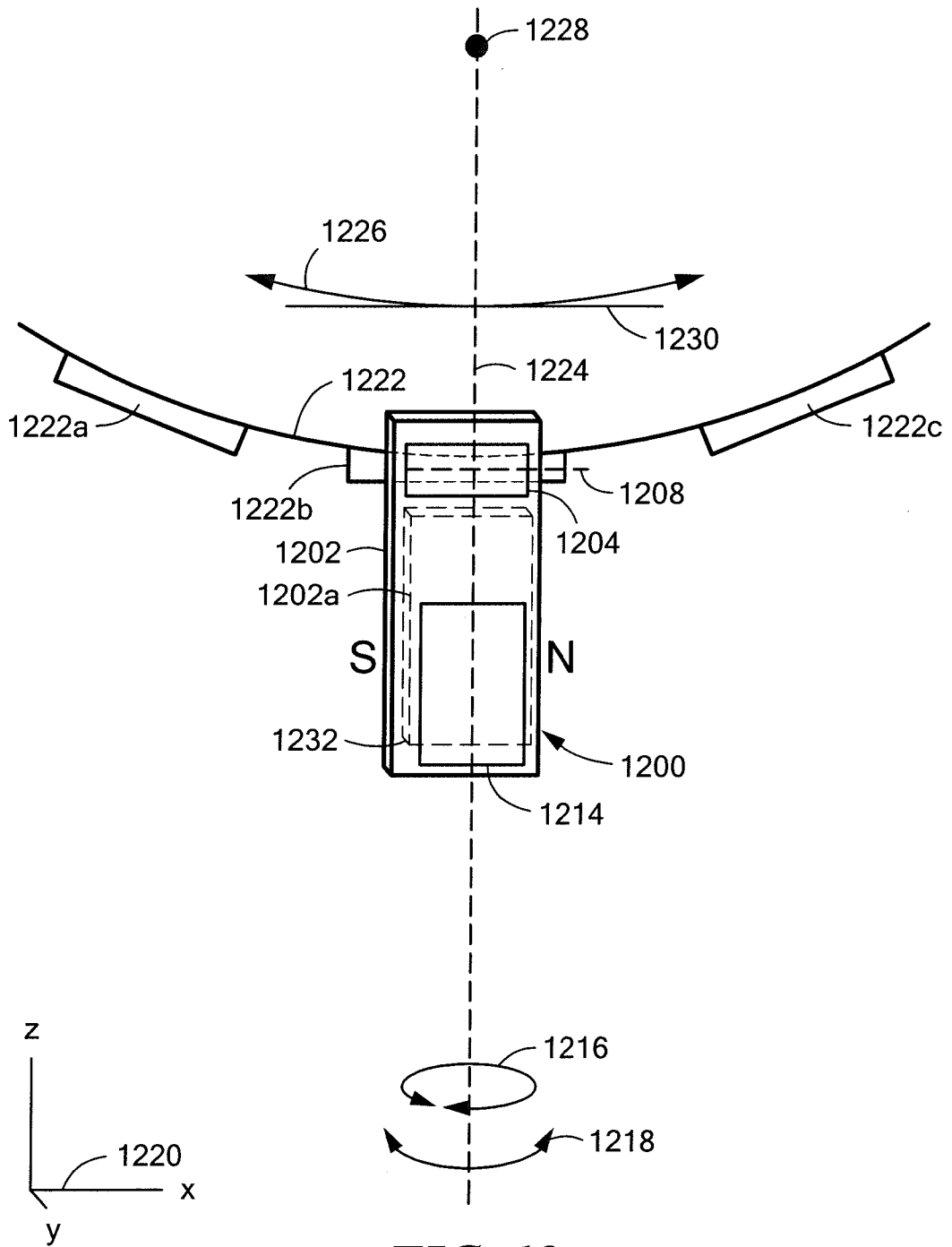

FIG. 12

15/18

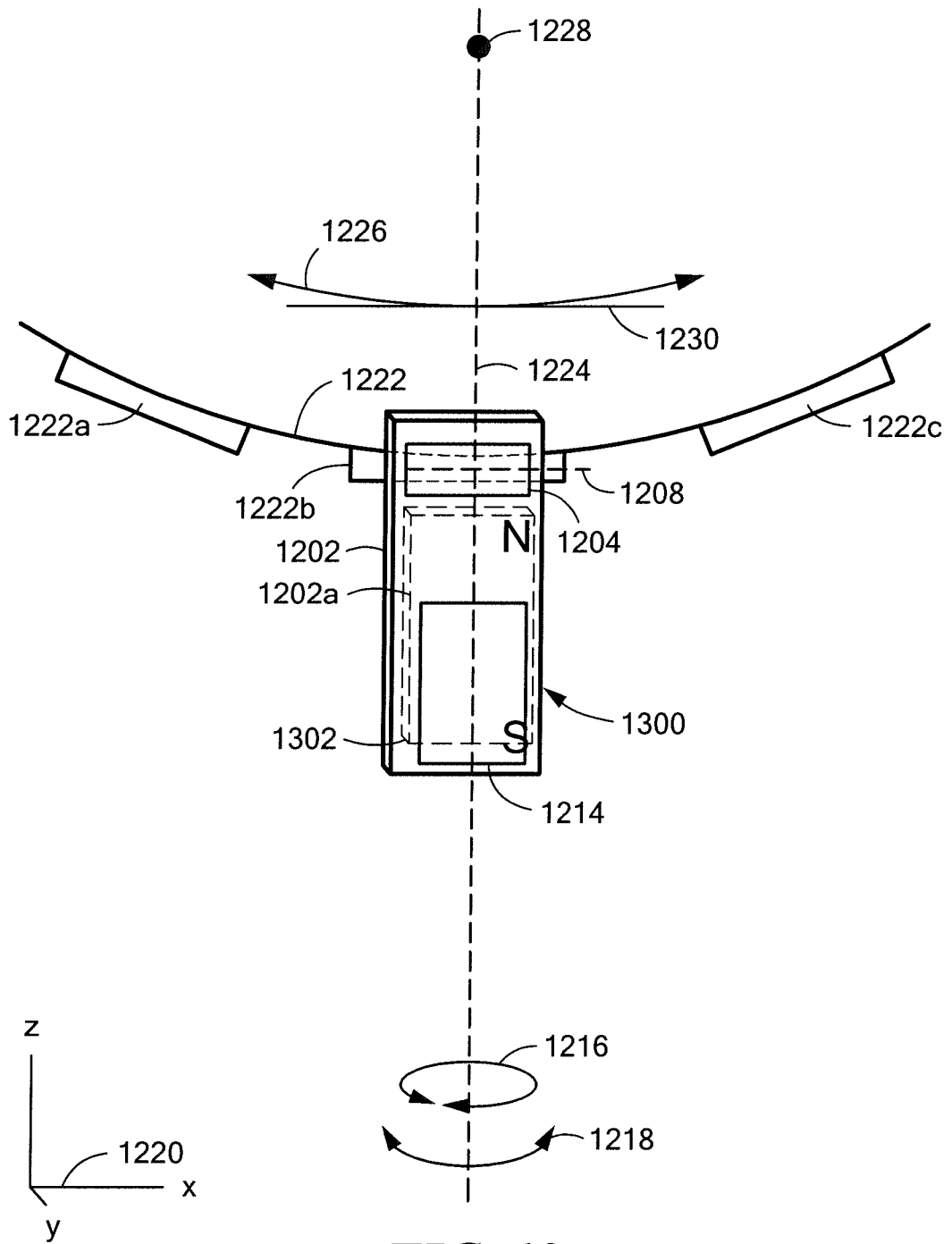

FIG. 13

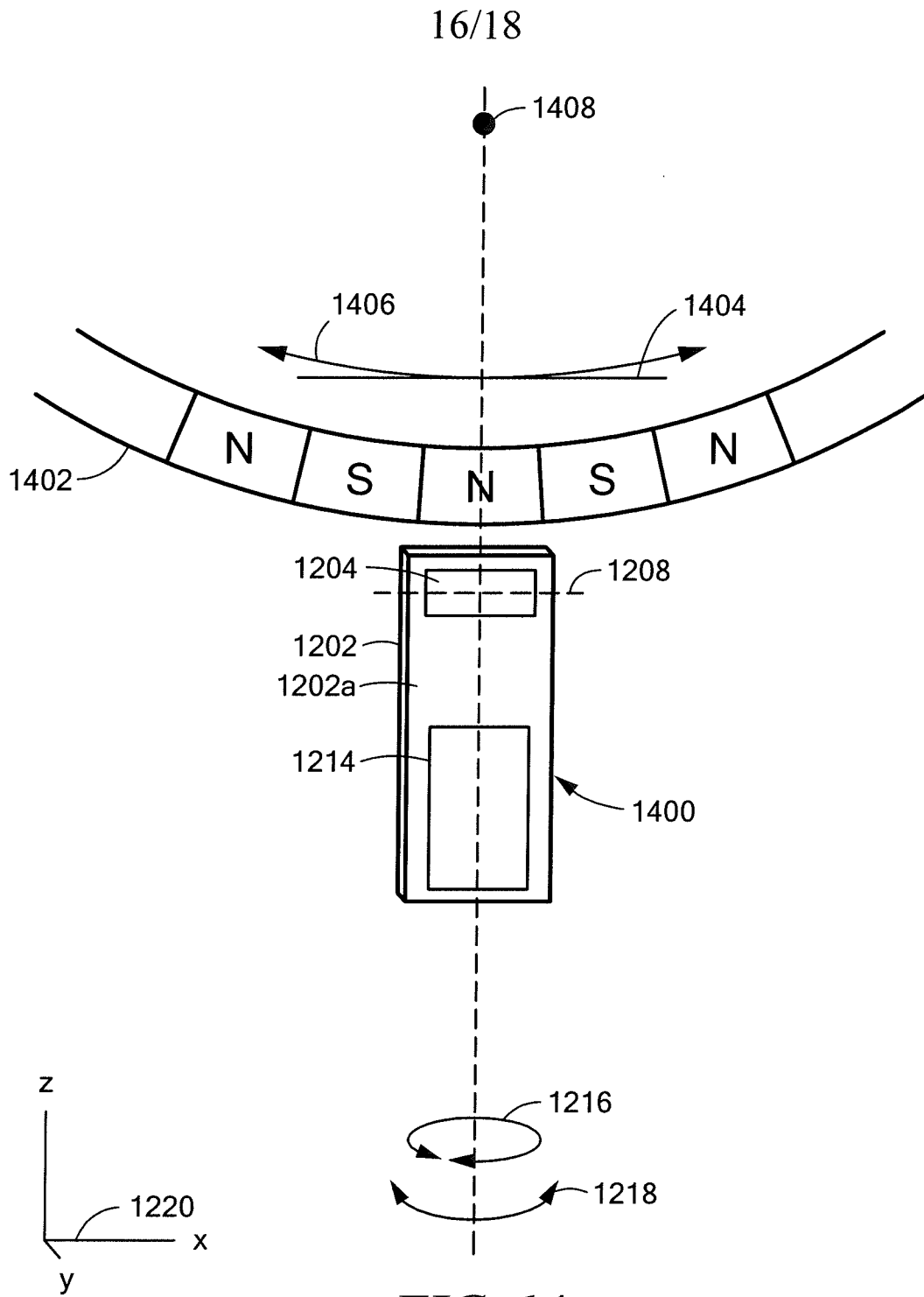

FIG. 14

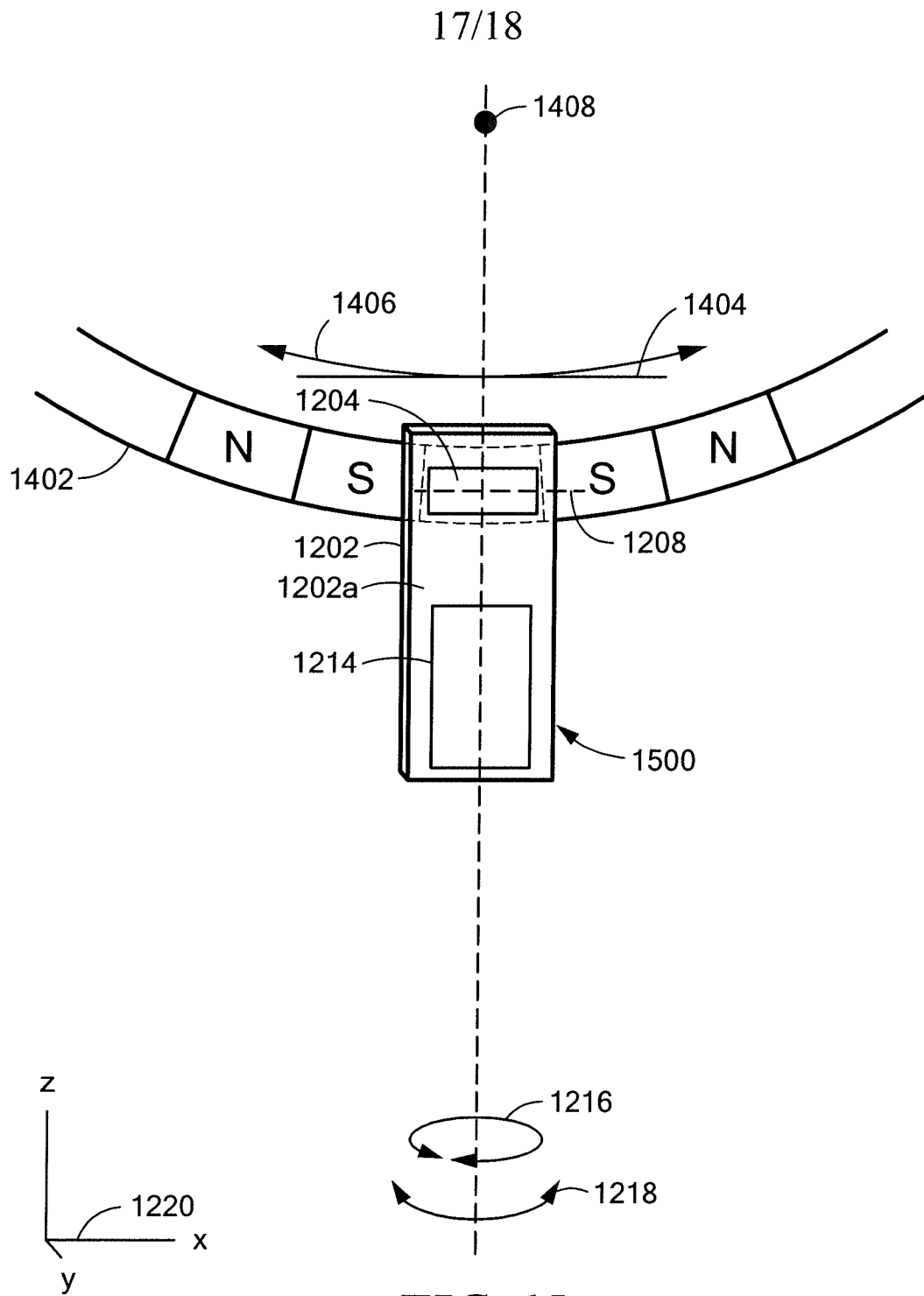

FIG. 15

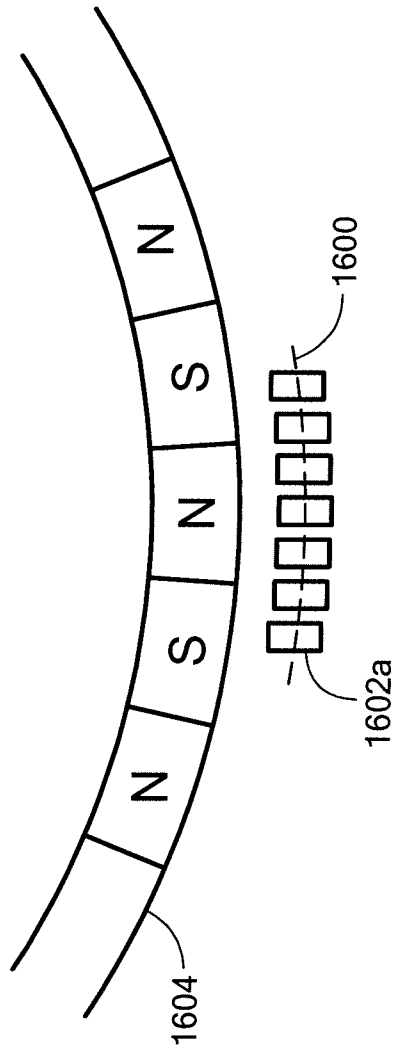

FIG. 16

INTERNATIONAL SEARCH REPORT

International application No
PCT/US2015/055233

A. CLASSIFICATION OF SUBJECT MATTER
INV. G01D5/14
ADD.
According to International Patent Classification (IPC) or to both national classification and IPC

B. FIELDS SEARCHED
Minimum documentation searched (classification system followed by classification symbols)
G01D G01P G01R

Documentation searched other than minimum documentation to the extent that such documents are included in the fields searched

Electronic data base consulted during the international search (name of data base and, where practicable, search terms used)
EPO-Internal, WPI Data

C. DOCUMENTS CONSIDERED TO BE RELEVANT

Category*	Citation of document, with indication, where appropriate, of the relevant passages	Relevant to claim No.
X	US 6 297 628 B1 (BICKING ROBERT E [US] ET AL) 2 October 2001 (2001-10-02)	1-4, 8-28, 31-35, 37-40
Y	Abstract, Desc. col. 1 / l. 36-38, col. 2 / l. 11-18, 49-54, 62-67, col. 3 / l. 33-60, claim 1, Figs. 1-4 -----	3-7, 10-30, 36,41,42
Y	US 2014/266176 A1 (FERNANDEZ DEVON [US] ET AL) 18 September 2014 (2014-09-18)	3-7, 10-19, 21-31, 36,41
A	Abstract, Desc. [0042]-[0071], Figs. 1, 4 ----- -/--	1,2,9, 20, 32-35, 37-40,42

Further documents are listed in the continuation of Box C.

See patent family annex.

* Special categories of cited documents :

- "A" document defining the general state of the art which is not considered to be of particular relevance
- "E" earlier application or patent but published on or after the international filing date
- "L" document which may throw doubts on priority claim(s) or which is cited to establish the publication date of another citation or other special reason (as specified)
- "O" document referring to an oral disclosure, use, exhibition or other means
- "P" document published prior to the international filing date but later than the priority date claimed

"T" later document published after the international filing date or priority date and not in conflict with the application but cited to understand the principle or theory underlying the invention

"X" document of particular relevance; the claimed invention cannot be considered novel or cannot be considered to involve an inventive step when the document is taken alone

"Y" document of particular relevance; the claimed invention cannot be considered to involve an inventive step when the document is combined with one or more other such documents, such combination being obvious to a person skilled in the art

"&" document member of the same patent family

Date of the actual completion of the international search 11 December 2015	Date of mailing of the international search report 23/12/2015
Name and mailing address of the ISA/ European Patent Office, P.B. 5818 Patentlaan 2 NL - 2280 HV Rijswijk Tel. (+31-70) 340-2040, Fax: (+31-70) 340-3016	Authorized officer Reim, Klaus

INTERNATIONAL SEARCH REPORT

International application No
PCT/US2015/055233

C(Continuation). DOCUMENTS CONSIDERED TO BE RELEVANT		
Category*	Citation of document, with indication, where appropriate, of the relevant passages	Relevant to claim No.
Y	US 2012/249133 A1 (FRIEDRICH ANDREAS P [FR]) 4 October 2012 (2012-10-04)	3,5,6, 11-13, 16-20, 22-28, 36,42
A	Abstract, Desc. [0022], [0037]-[0039], [0049], Figs. 1a, 4d-1	1,4, 7-10,14, 15,21, 29-35, 37-41
Y	----- US 2003/173955 A1 (UENOYAMA HIROFUMI [JP]) 18 September 2003 (2003-09-18)	10,11,31
A	Abstract, Desc. [0033]-[0041], [0051], fig. 8 -----	1-9, 12-30, 32-42

INTERNATIONAL SEARCH REPORT

Information on patent family members

International application No PCT/US2015/055233

Patent document cited in search report	Publication date	Patent family member(s)	Publication date	
US 6297628	B1	02-10-2001	CA 2351525 A1	25-05-2000
			DE 69907016 D1	22-05-2003
			DE 69907016 T2	18-12-2003
			EP 1131606 A1	12-09-2001
			JP 2002530638 A	17-09-2002
			US 6297628 B1	02-10-2001
			WO 0029815 A1	25-05-2000

US 2014266176	A1	18-09-2014	EP 2962069 A1	06-01-2016
			US 2014266176 A1	18-09-2014
			WO 2014149238 A1	25-09-2014

US 2012249133	A1	04-10-2012	EP 2678702 A1	01-01-2014
			JP 5745160 B2	08-07-2015
			JP 2014510286 A	24-04-2014
			KR 20140019802 A	17-02-2014
			US 2012249133 A1	04-10-2012
			WO 2012134751 A1	04-10-2012

US 2003173955	A1	18-09-2003	CN 1445512 A	01-10-2003
			DE 10311086 A1	02-10-2003
			FR 2837279 A1	19-09-2003
			JP 4190780 B2	03-12-2008
			JP 2003269995 A	25-09-2003
			KR 20030076316 A	26-09-2003
			US 2003173955 A1	18-09-2003
