

(No Model.)

F. M. ASHLEY.  
TUBULAR APPARATUS.

No. 526,553.

Patented Sept. 25, 1894.

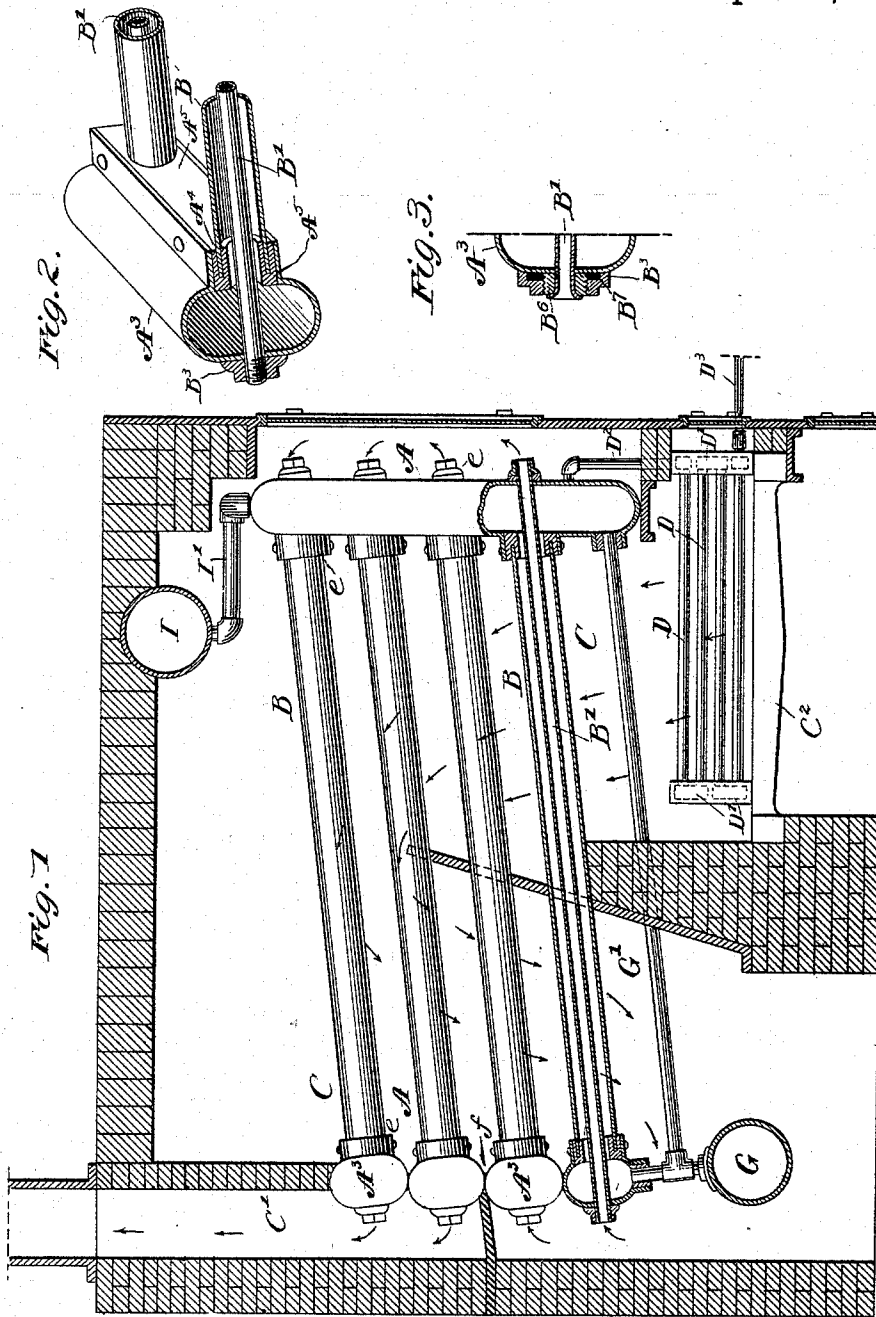

WITNESSES:  
*Frank S. Ober.*  
*C. V. Edwards.*

INVENTOR  
*Frank M. Ashley*  
BY  
*M. A. Rosenberg*  
ATTORNEY

# UNITED STATES PATENT OFFICE.

FRANK M. ASHLEY, OF HAWTHORNE, NEW JERSEY.

## TUBULAR APPARATUS.

SPECIFICATION forming part of Letters Patent No. 526,553, dated September 25, 1894.

Application filed October 5, 1892. Serial No. 447,925. (No model.)

*To all whom it may concern:*

Be it known that I, FRANK M. ASHLEY, a citizen of the United States, residing in the town of Hawthorne, county of Passaic, and State of New Jersey, have invented certain new and useful Improvements in Tubular Apparatus, of which the following is a specification.

This invention relates to tubular apparatus in which are employed tubes having extending through them other tubes, said inner and outer tubes being independently connected with end chambers, and the chambers being so arranged in relation to a boiler, furnace, and other apparatus, as to permit the heating of liquids or gases in their circulation through the outer tubes.

This invention is capable of use for heating water, in generating steam, as in a steam boiler, and also for heating a current of water or other liquid in continuous circulation.

The object of the invention is to provide an improved tubular apparatus of this character, by means of which a more perfect circulation and result is attained and in which the parts are better adapted to sustain pressure and are economical and strong.

Referring to the accompanying drawings, in which the invention is shown as employed in the form of heating apparatus, and in which similar letters of reference indicate like parts: Figure 1 is a side elevation, partly in section, of a tubular apparatus, constructed in accordance with this invention, applied to a steam boiler. Fig. 2 is a detail of an end head, partly in cross-section, and Fig. 3 illustrates a method of fastening the inner pipes to the end heads.

A A indicate two hollow heads of the tubular apparatus and B B' the outer and inner tubes respectively, of each of a number of double tubes combined with the heads. Each of the heads A is formed in sections A<sup>3</sup>, the sections of one head being preferably located at right angles to the sections of the other. Each of the sections A<sup>3</sup> are of oval or elliptical shape in cross-section, thus strengthening and better adapting the same to resist the steam pressure therein, which advantage is due to the superior elasticity thus imparted to the sections. The outer tube B of each set

of tubes communicates with a section A<sup>3</sup>, at each end, and the inner tube B' thereof extends through a section A<sup>3</sup> at each end. The tubes B and B' are preferably separated from the sections A<sup>3</sup>. Each section A<sup>3</sup>, of one head A, is parallel and common to a horizontal row of tubes B B', while each section A<sup>3</sup> of the other head A is parallel and common to a vertical row of such tubes, thus producing a direct inter-communication of the several sections whereby the required circulation of the water or steam, or both, in the heads and tubes is maintained. This circulation of the water or steam may be promoted by arranging the tubes B B' in an inclined position, as shown in Fig. 1.

The tubes B B' may be separably jointed to the sections A<sup>3</sup> in various ways, but are preferably jointed as shown in Figs. 2 and 3.

Fig. 2 is a detailed view of the form in which I construct my end heads.

A<sup>5</sup> is a heavy filling piece, to which the edges of the sheet metal body A<sup>3</sup> are secured, by riveting or otherwise. In the exposed side of the filling piece are formed grooves A<sup>4</sup> into which the ends of the outer pipes B fit, so that the outer pipes will form braces against which the filling pieces of the two opposite end heads will rest and will thereby be prevented from being blown out by the pressure of the steam. The inner pipes B' pass through the filling piece A<sup>5</sup> and through the outer side of the sheet metal body A<sup>3</sup>. A nut B<sup>3</sup> is then screwed down over the end of the pipe against the sheet metal body, thus forming a flange against which the body will be forced by the outward pressure of the steam in the end head. As the pipe B' also passes through to the outer side of the opposite end head and is there connected in the same manner, it will also serve as a brace to prevent the sheet metal body of the end head from being blown outward.

In Fig. 3 is shown a modified form of joining the inner tube to the end section. After the tube B' is passed through the end section A<sup>3</sup>, a collar B<sup>6</sup> is fitted over the end of the tube and against the end section. The end of the tube is then turned over and beaded against this collar, and the nut B<sup>3</sup>, which en-

gages a thread cut on the collar B<sup>6</sup>, is then screwed down upon the ring of packing material B<sup>7</sup> inserted between the nut and the end head. If preferred I may screw the nut<sup>5</sup> down on the end of the tube against the ring of packing material and not use the collar B<sup>6</sup>, but I prefer to use the collar as the joint is thereby made much stronger. Again, I may dispense with the nut and turn the end<sup>10</sup> of the tube over and bead it against a washer which bears upon a ring of packing material inserted between the washer and the end section.

The tubes B B' are inclosed in a fire chamber C, as shown.

With this arrangement of tubes B B', and heads A, as set forth, water supplied to either of the heads A is received in the spaces between tubes B B' and is exposed to the action of the heat in chamber C and in the inner tubes B', whereby a large area of heating surface is thus obtained and a rapid generation of steam produced in the boiler. The heat, after passing over the tubes B and through tubes B', escapes through a flue C'.<sup>20</sup>

At the opposite sides of the fire chamber c, and at a point next above the grate C<sup>2</sup> of said chamber, are located pipes D, for the purpose of partially heating the feed water for the end heads and tubes by means of a fire on the grate. Each set of these feed water heating pipes D has return couplings D' and is connected by a pipe D<sup>2</sup> leading from one of these couplings to one of the heads A, which in turn are connected by a pipe D<sup>3</sup> with a suitable feed pump.<sup>25</sup>

The lower part of each of the heads A is connected by means of pipes G' to a mud drum C, so as to render this drum common to both, the mud drum having a suitable outlet, which is not shown in the drawings. Each of the heads A is also connected by suitable pipes I' to a steam drum I located above the tubes B B' at the top of the fire chamber G.<sup>30</sup>

The spent heat discharging from chamber C thus acts directly on the steam drum I, with a tendency to superheat the steam therein.

Having thus described my invention, I claim—

50 1. In the hollow end heads of a tubular apparatus as herein set forth, the combination of a filling piece, a sheet metal body fastened thereto, and external and internal tubes, said external tubes fitting into a groove in the filling piece and said internal tubes passing through the filling piece and the sheet metal body.<sup>55</sup>

60 2. In the hollow end heads of a tubular apparatus as herein set forth, the combination of a filling piece, a longitudinal sheet metal body fastened thereto, and external and internal tubes, said external tubes fitting into a groove in the filling piece and said internal tubes passing through the filling piece and the sheet metal body.<sup>65</sup>

3. In the hollow end heads of a tubular apparatus as herein set forth, the combination of a filling piece, a sheet metal body fastened thereto, and external and internal tubes, said external tubes fitting into a groove in the filling piece and said internal tubes passing through the filling piece and the sheet metal body and being secured thereto by a nut, a ring of packing material being inserted between the nut and the end head.<sup>70</sup>

75 4. In the hollow end heads of a tubular apparatus as herein set forth, the combination of a filling piece, a sheet metal body fastened thereto, and external and internal tubes, said external tubes fitting into a groove in the filling piece and said internal tubes passing through the filling piece and the sheet metal body and being secured thereto by a nut, a ring of fire proof packing material being inserted between the nut and the end head.<sup>80</sup>

85 5. In a tubular apparatus as herein set forth, abutting head sections of oval or elliptic shape, formed of sheet metal and having a longitudinal filling piece secured thereto, with passages for the internal tubes and recesses for the external tubes in combination with screw rings which clamp the said internal and external tubes to the sections.<sup>90</sup>

95 6. In a tubular apparatus as herein set forth, abutting end sections of oval or elliptic shape formed of sheet metal and having a longitudinal filling piece secured thereto, with passages for the internal tubes and recesses for the external tubes, in combination with screw rings or nuts which clamp the said internal and external tubes to the sections and a ring of packing material being interposed between the nut and the end section.<sup>100</sup>

105 7. In a tubular apparatus as herein set forth, abutting end sections of oval or elliptic shape formed of sheet metal and having a longitudinal filling piece secured thereto, with passages for the internal tubes and recesses for the external tubes, in combination with screw rings or nuts which clamp the said internal and external tubes to the sections and a ring of fire proof packing material being interposed between the nut and the end section.<sup>110</sup>

115 8. The combination with a fire chamber, of a tubular apparatus consisting of hollow heads formed of abutting hollow sections of oval or elliptic shape, a number of tubes each composed of external and internal tubes, the latter projecting through the hollow sections, and the former communicating with the hollow sections, a mud drum connected to each of the heads, and a steam drum located above the tubes in the line of draft of the fire chamber and connected to the heads, and feed water heating pipes located next above the grate of the fire chamber and connected with one of the heads.<sup>120</sup>

125 9. The combination with a fire chamber, of a tubular apparatus consisting of hollow end heads formed of abutting hollow sheet metal  
130

sections of oval or elliptic shape, a number of tubes each composed of external and internal tubes, the latter projecting through the hollow sections and the former communicating  
5 with the hollow sections, a mud drum connected to each of the heads, and a steam drum located above the tubes in the line of draft of the fire chamber and connected to the heads, and feed water heating pipes located next

above the grate of the fire chamber and connected with one of the heads.

In testimony whereof I subscribe my signature in presence of two witnesses.

FRANK M. ASHLEY.

Witnesses:

WM. A. ROSENBAUM,  
FRANK S. OBER.