

(12) PATENT
(19) AUSTRALIAN PATENT OFFICE

(11) Application No. AU 199529661 B2
(10) Patent No. 708677

(54) Title
Self-addressable self-assembling microelectronic systems and devices for molecular biological analysis and diagnostics

(51)⁶ International Patent Classification(s)
G01N 033/50 C12Q 001/68

(21) Application No: **199529661** (22) Application Date: **1995 .07 .05**

(87) WIPO No: **WO96/01836**

(30) Priority Data

(31) Number	(32) Date	(33) Country
08/271882	1994 .07 .07	US

(43) Publication Date : **1996 .02 .09**

(43) Publication Journal Date : **1996 .03 .21**

(44) Accepted Journal Date : **1999 .08 .12**

(71) Applicant(s)
Nanogen, Inc.

(72) Inventor(s)
Michael J Heller; Eugene Tu; Glen A Evans; Ronald G Sosnowski

(74) Agent/Attorney
SPRUSON and FERGUSON,GPO Box 3898,SYDNEY NSW 2001

(56) Related Art
AU 40787/89
US 5200051
US 5063081

OPI DATE 09/02/96 APPLN. ID 29661/95
AOJP DATE 21/03/96 PCT NUMBER PCT/US95/08570



AU9529661

(PCT)

(51) International Patent Classification ⁶ : C07H 21/00	A1	(11) International Publication Number: WO 96/01836 (43) International Publication Date: 25 January 1996 (25.01.96)
(21) International Application Number: PCT/US95/08570 (22) International Filing Date: 5 July 1995 (05.07.95) (30) Priority Data: 08/271,882 7 July 1994 (07.07.94) US (71) Applicant: NANOGEN, INC. [US/US]; 10398 Pacific Center Court, San Diego, CA 92121 (US). (72) Inventors: HELLER, Michael, J.; 1614 Hawk View Drive, Encinitas, CA 92024 (US). TU, Eugene; 3527 Lark Street, San Diego, CA 92103 (US). EVANS, Glen, A.; 6504 Myrtle Beach Drive, Plano, TX 95093 (US). SOSNOWSKI, Ronald, G.; 1013 Adella Avenue, Coronado, CA 92118 (US). (74) Agents: MURPHY, David, B. et al.; Lyon & Lyon, First Interstate World Center, Suite 4700, 633 West Fifth Street, Los Angeles, CA 90071-2066 (US).	(81) Designated States: AU, BR, CA, CN, FI, JP, NZ, European patent (AT, BE, CH, DE, DK, ES, FR, GB, GR, IE, IT, LU, MC, NL, PT, SE). Published <i>With international search report.</i>	
(54) Title: SELF-ADDRESSABLE SELF-ASSEMBLING MICROELECTRONIC SYSTEMS AND DEVICES FOR MOLECULAR BIOLOGICAL ANALYSIS AND DIAGNOSTICS		
(57) Abstract <p>A self-addressable, self-assembling microelectronic device is designed and fabricated to actively carry out and control multi-step and multiplex molecular biological reactions in microscopic formats. These reactions include nucleic acid hybridizations, antibody/antigen reactions, diagnostics, and biopolymer synthesis. The device can be fabricated using both microlithographic and micro-machining techniques. The device can electronically control the transport and attachment of specific binding entities to specific micro-locations. The specific binding entities include molecular biological molecules such as nucleic acids and polypeptides. The device can subsequently control the transport and reaction of analytes or reactants at the addressed specific micro-locations. The device is able to concentrate analytes and reactants, remove non-specifically bound molecules, provide stringency control for DNA hybridization reactions, and improve the detection of analytes. The device can be electronically replicated.</p>		

DESCRIPTION

SELF-ADDRESSABLE SELF-ASSEMBLING
MICROELECTRONIC SYSTEMS AND DEVICES
FOR MOLECULAR BIOLOGICAL ANALYSIS AND DIAGNOSTICS

Field of the Invention

This invention pertains to the design, fabrication, and uses of a self-addressable, self-assembling microelectronic system which can actively carry out and control multi-step
5 and multiplex reactions in microscopic formats. In particular, these reactions include molecular biological reactions, such as nucleic acid hybridizations, nucleic acid amplification, sample preparation, antibody/antigen reactions, clinical diagnostics, and biopolymer synthesis.

10 Background of the Invention

Molecular biology comprises a wide variety of techniques for the analysis of nucleic acids and proteins, many of which form the basis of clinical diagnostic assays. These techniques include nucleic acid hybridization
15 analysis, restriction enzyme analysis, genetic sequence analysis, and separation and purification of nucleic acids and proteins (See, e.g., J. Sambrook, E. F. Fritsch, and T. Maniatis, Molecular Cloning: A Laboratory Manual, 2 Ed., Cold Spring Harbor Laboratory Press, Cold Spring Harbor,
20 New York, 1989).

Many molecular biology techniques involve carrying out numerous operations on a large number of samples. They are often complex and time consuming, and generally require a high degree of accuracy. Many a technique is limited in
25 its application by a lack of sensitivity, specificity, or reproducibility. For example, problems with sensitivity

and specificity have so far limited the practical applications of nucleic acid hybridization.

Nucleic acid hybridization analysis generally involves the detection of a very small number of specific target
5 nucleic acids (DNA or RNA) with probes among a large amount of non-target nucleic acids. In order to keep high specificity, hybridization is normally carried out under the most stringent conditions, achieved through various combinations of temperature, salts, detergents, solvents,
10 chaotropic agents, and denaturants.

Multiple sample nucleic acid hybridization analysis has been conducted on a variety of filter and solid support formats (see G. A. Beltz et al., in Methods in Enzymology, Vol. 100, Part B, R. Wu, L. Grossmam, K. Moldave, Eds.,
15 Academic Press, New York, Chapter 19, pp. 266-308, 1985). One format, the so-called "dot blot" hybridization, involves the non-covalent attachment of target DNAs to a filter, which are subsequently hybridized with a radioisotope labeled probe(s). "Dot blot" hybridization
20 gained wide-spread use, and many versions were developed (see M. L. M. Anderson and B. D. Young, in Nucleic Acid Hybridization - A Practical Approach, B. D. Hames and S. J. Higgins, Eds., IRL Press, Washington DC, Chapter 4, pp. 73-111, 1985). The "dot blot" hybridization has been
25 further developed for multiple analysis of genomic mutations (D. Nanibhushan and D. Rabin, in EPA 0228075, July 8, 1987) and for the detection of overlapping clones and the construction of genomic maps (G. A. Evans, in US Patent #5,219,726, June 15, 1993).

30 Another format, the so-called "sandwich" hybridization, involves attaching oligonucleotide probes covalently to a solid support and using them to capture and detect multiple nucleic acid targets. (M. Ranki et al.,

Gene, 21, pp. 77-85, 1983; A. M. Palva, T. M. Ranki, and H. E. Soderlund, in UK Patent Application GB 2156074A, October 2, 1985; T. M. Ranki and H. E. Soderlund in US Patent # 4,563,419, January 7, 1986; A. D. B. Malcolm and
5 J. A. Langdale, in PCT WO 86/03782, July 3, 1986; Y. Stabinsky, in US Patent # 4,751,177, January 14, 1988; T. H. Adams et al., in PCT WO 90/01564, February 22, 1990; R. B. Wallace et al. 6 Nucleic Acid Res. 11, p. 3543, 1979; and B. J. Connor et al., 80 Proc. Natl. Acad. Sci. USA
10 pp. 278-282, 1983). Multiplex versions of these formats are called "reverse dot blots".

Using the current nucleic acid hybridization formats and stringency control methods, it remains difficult to detect low copy number (i.e., 1-100,000) nucleic acid
15 targets even with the most sensitive reporter groups (enzyme, fluorophores, radioisotopes, etc.) and associated detection systems (fluorometers, luminometers, photon counters, scintillation counters, etc.).

This difficulty is caused by several underlying
20 problems associated with direct probe hybridization. One problem relates to the stringency control of hybridization reactions. Hybridization reactions are usually carried out under the stringent conditions in order to achieve hybridization specificity. Methods of stringency control
25 involve primarily the optimization of temperature, ionic strength, and denaturants in hybridization and subsequent washing procedures. Unfortunately, the application of these stringency conditions causes a significant decrease in the number of hybridized probe/target complexes for
30 detection.

Another problem relates to the high complexity of DNA in most samples, particularly in human genomic DNA samples. When a sample is composed of an enormous number of

sequences which are closely related to the specific target sequence, even the most unique probe sequence has a large number of partial hybridizations with non-target sequences.

A third problem relates to the unfavorable hybridization dynamics between a probe and its specific target. Even under the best conditions, most hybridization reactions are conducted with relatively low concentrations of probes and target molecules. In addition, a probe often has to compete with the complementary strand for the target nucleic acid.

A fourth problem for most present hybridization formats is the high level of non-specific background signal. This is caused by the affinity of DNA probes to almost any material.

These problems, either individually or in combination, lead to a loss of sensitivity and/or specificity for nucleic acid hybridization in the above described formats. This is unfortunate because the detection of low copy number nucleic acid targets is necessary for most nucleic acid-based clinical diagnostic assays.

Because of the difficulty in detecting low copy number nucleic acid targets, the research community relies heavily on the polymerase chain reaction (PCR) for the amplification of target nucleic acid sequences (see M. A. Innis et al., PCR Protocols: A Guide to Methods and Applications, Academic Press, 1990). The enormous number of target nucleic acid sequences produced by the PCR reaction improves the subsequent direct nucleic acid probe techniques, albeit at the cost of a lengthy and cumbersome procedure.

A distinctive exception to the general difficulty in detecting low copy number target nucleic acid with a direct probe is the in-situ hybridization technique. This

technique allows low copy number unique nucleic acid sequences to be detected in individual cells. In the in-situ format, target nucleic acid is naturally confined to the area of a cell (~20-50 μm^2) or a nucleus (~10 μm^2) at a relatively high local concentration. Furthermore, the probe/target hybridization signal is confined to a microscopic and morphologically distinct area; this makes it easier to distinguish a positive signal from artificial or non-specific signals than hybridization on a solid support.

Mimicking the in-situ hybridization in some aspects, new techniques are being developed for carrying out multiple sample nucleic acid hybridization analysis on micro-formatted multiplex or matrix devices (e.g., DNA chips) (see M. Barinaga, 253 Science, pp. 1489, 1991; W. Bains, 10 Bio/Technology, pp. 757-758, 1992). These methods usually attach specific DNA sequences to very small specific areas of a solid support, such as micro-wells of a DNA chip. These hybridization formats are micro-scale versions of the conventional "reverse dot blot" and "sandwich" hybridization systems.

The micro-formatted hybridization can be used to carry out "sequencing by hybridization" (SBH) (see M. Barinaga, 253 Science, pp. 1489, 1991; W. Bains, 10 Bio/Technology, pp. 757-758, 1992). SBH makes use of all possible n-nucleotide oligomers (n-mers) to identify n-mers in an unknown DNA sample, which are subsequently aligned by algorithm analysis to produce the DNA sequence (R. Drmanac and R. Crkvenjakov, Yugoslav Patent Application #570/87, 1987; R. Drmanac et al., 4 Genomics, 114, 1989; Strezoska et al., 88 Proc. Natl. Acad. Sci. USA 10089, 1991; and R. Drmanac and R. B. Crkvenjakov, US Patent #5,202,231, April 13, 1993).

There are two formats for carrying out SBH. One format involves creating an array of all possible n-mers on a support, which is then hybridized with the target sequence. This is a version of the reverse dot blot.

5 Another format involves attaching the target sequence to a support, which is sequentially probed with all possible n-mers. Both formats have the fundamental problems of direct probe hybridizations and additional difficulties related to multiplex hybridizations.

10 Southern, United Kingdom Patent Application GB 8810400, 1988; E. M. Southern et al., 13 Genomics 1008, 1992, proposed using the "reverse dot blot" format to analyze or sequence DNA. Southern identified a known single point mutation using PCR amplified genomic DNA.

15 Southern also described a method for synthesizing an array of oligonucleotides on a solid support for SBH. However, Southern did not address how to achieve optimal stringency condition for each oligonucleotide on an array.

Fodor et al., 364 Nature, pp. 555-556, 1993, used an
20 array of 1,024 8-mer oligonucleotides on a solid support to sequence DNA. In this case, the target DNA was a fluorescently labeled single-stranded 12-mer oligonucleotide containing only the A and C bases. A concentration of 1 pmol ($\sim 6 \times 10^{11}$ molecules) of the 12-mer
25 target sequence was necessary for the hybridization with the 8-mer oligomers on the array. The results showed many mismatches. Like Southern, Fodor et al., did not address the underlying problems of direct probe hybridization, such as stringency control for multiplex hybridizations. These
30 problems, together with the requirement of a large quantity of the simple 12-mer target, indicate severe limitations to this SBH format.

Concurrently, Drmanac et al., 260 Science 1649-1652, 1993, used the above discussed second format to sequence several short (116 bp) DNA sequences. Target DNAs were attached to membrane supports ("dot blot" format). Each filter was sequentially hybridized with 272 labeled 10-mer and 11-mer oligonucleotides. A wide range of stringency conditions were used to achieve specific hybridization for each n-mer probe; washing times varied from 5 minutes to overnight, and temperatures from 0°C to 16°C. Most probes required 3 hours of washing at 16°C. The filters had to be exposed for 2 to 18 hours in order to detect hybridization signals. The overall false positive hybridization rate was 5% in spite of the simple target sequences, the reduced set of oligomer probes, and the use of the most stringent conditions available.

Fodor et al., 251 Science 767-773, 1991, used photolithographic techniques to synthesize oligonucleotides on a matrix. Pirrung et al., in US Patent # 5,143,854, September 1, 1992, teach large scale photolithographic solid phase synthesis of polypeptides in an array fashion on silicon substrates.

In another approach of matrix hybridization, Beattie et al., in The 1992 San Diego Conference: Genetic Recognition, November, 1992, used a microrobotic system to deposit micro-droplets containing specific DNA sequences into individual microfabricated sample wells on a glass substrate. The hybridization in each sample well is detected by interrogating miniature electrode test fixtures, which surround each individual microwell with an alternating current (AC) electric field.

Regardless of the format, all current micro-scale DNA hybridizations and SBH approaches do not overcome the underlying problems associated with nucleic acid hybridization reactions. They require very high levels of relatively short single-stranded target sequences or PCR amplified DNA, and produce a high level of false positive hybridization signals even under the most stringent conditions. In the case of multiplex formats using arrays of short oligonucleotide sequences, it is not possible to optimize the stringency condition for each individual sequence with any conventional approach because the arrays or devices used for these formats can not change or adjust the temperature, ionic strength, or denaturants at an individual location, relative to other locations. Therefore, a common stringency condition must be used for all the sequences on the device. This results in a large number of non-specific and partial hybridizations and severely limits the application of the device. The problem becomes more compounded as the number of different sequences on the array increases, and as the length of the sequences decreases below 10-mers or increases above 20-mers. This is particularly troublesome for SBH, which requires a large number of short oligonucleotide probes.

Nucleic acids of different size, charge, or conformation are routinely separated by electrophoresis techniques which can distinguish hybridization species by their differential mobility in an electric field. Pulse field electrophoresis uses an arrangement of multiple electrodes around a medium (e.g., a gel) to separate very large DNA fragments which cannot be resolved by conventional gel electrophoresis systems (see R. Anand and E. M. Southern in Gel Electrophoresis of Nucleic Acids - A Practical Approach, 2 ed., D. Rickwood and B. D. Hames Eds., IRL Press, New York, pp. 101-122, 1990).

Pace, US Patent #4,908,112, March 13, 1990, describes using micro-fabrication techniques to produce a capillary gel electrophoresis system on a silicon substrate.

Multiple electrodes are incorporated into the system to move molecules through the separation medium within the device.

Soane and Soane, US Patent 5,126,022, June 30, 1992, describe that a number of electrodes can be used to control the linear movement of charged molecules in a mixture through a gel separation medium contained in a tube. Electrodes have to be installed within the tube to control the movement and position of molecules in the separation medium.

Washizu, M. and Kurosawa, O., 26 IEEE Transactions on Industry Applications 6, pp. 1165-1172, 1990, used high-frequency alternating current (AC) fields to orient DNA molecules in electric field lines produced between microfabricated electrodes. However, the use of direct current (DC) fields is prohibitive for their work. Washizu 25 Journal of Electrostatics 109-123, 1990, describes the manipulation of cells and biological molecules using dielectrophoresis. Cells can be fused and biological

molecules can be oriented along the electric fields lines produced by AC voltages between the micro-electrode structures. However, the dielectrophoresis process requires a very high frequency AC (1 MHz) voltage and a low conductivity medium. While these techniques can orient DNA molecules of different sizes along the AC field lines, they cannot distinguish between hybridisation complexes of the same size.

As is apparent from the preceding discussion, numerous attempts have been made to provide effective techniques to conduct multi-step, multiplex molecular biological reactions. However, for the reasons stated above, these techniques have been proved deficient. Despite the long-recognised need for effective technique, no satisfactory solution has been proposed previously.

Summary of the Invention

The present invention relates to the design, fabrication, and uses of programmable, self-addressable and self-assembling microelectronic systems and devices which can actively carry out controlled multi-step and multiplex reactions in microscopic formats. These reactions include, but are not limited to, most molecular biological procedures, such as nucleic acid hybridisations, antibody/antigen reactions, and related clinical diagnostics. In addition, the claimed devices are able to carry out multi-step combinational biopolymer synthesis, including, but not limited to, the synthesis of different oligonucleotides or peptides at specific micro-locations.

According to one embodiment of the invention, there is provided a method for electronically controlled synthesis of biopolymers on a plurality of locations, comprising the steps of:

providing a plurality of reaction locations on a substrate, wherein each reaction location is individually electronically addressable;

providing an attachment layer upon each reaction location;

contacting said plurality of reaction location with a solution comprising a charged monomer-A;

selectively biasing a designated A location at which reaction A is to occur at an opposite charge to monomer-A, and biasing another location at which no reaction A is to occur the same charge as monomer-A, thereby concentration and reacting monomer A on said A location;

thereafter, removing the unreacted monomer A from said plurality of reaction locations;

contacting said plurality of reaction locations with a solution comprising a charged monomer-B; and



10a

selectively biasing said A location at the opposite charge of monomer-B, and biasing another location at which no reaction B is to occur the same charge as monomer-B, thereby concentrating and reacting monomer B on said A location to form dimer A-B.

According to another embodiment of the invention, there is provided a method for synthesising a plurality of polymers, the polymers being composed of monomers in selected positions, at a plurality of locations on an active, programmable electronic matrix device, comprising the steps of:

providing a selected charged reactant on the device adjacent the locations, synthesising the polymer by selectively:

10 biasing those locations attractive to the charged reactant where the polymer includes a specified monomer at the selected position, and simultaneously

biasing those locations repulsive to the charged reactant where the polymer does not include the specified monomer at said selected position,

selectively reacting the specific monomer, and

15 repeating the above steps by sequentially providing charged reactants to the device, and biasing the locations attractive and repulsive to include or exclude, respectively, a monomer at the selected positions.

The claimed devices are fabricated using both microlithographic and micro-machining techniques. The devices have a matrix of addressable microscopic locations on their surface; each individual micro-location is able to

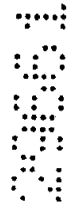

electronically control and direct the transport and attachment of specific binding entities (e.g., nucleic acids, antibodies) to itself. All micro-locations can be addressed with their specific binding entities. Using
5 these devices, the system can be self-assembled with minimal outside intervention.

The addressed devices are able to control and actively carry out a variety of assays and reactions. Analytes or reactants can be transported by free field electrophoresis
10 to any specific micro-location where the analytes or reactants are effectively concentrated and reacted with the specific binding entity at said micro-location. The sensitivity for detecting a specific analyte or reactant is improved because of the concentrating effect. Any un-bound
15 analytes or reactants can be removed by reversing the polarity of a micro-location. Thus, the devices also improve the specificity of assays and reactions.

The active nature of the devices provides independent electronic control over all aspects of the hybridization
20 reaction (or any other affinity reaction) occurring at each specific micro-location. These devices provide a new mechanism for affecting hybridization reactions which is called electronic stringency control (ESC). For DNA hybridization reactions which require different stringency
25 conditions, ESC overcomes the inherent limitation of conventional array technologies. The active devices of this invention can electronically produce "different stringency conditions" at each micro-location. Thus, all hybridizations can be carried out optimally in the same
30 bulk solution. These active devices are fundamentally different from conventional multiplex hybridization arrays and DNA chips. While conventional arrays have different probes or target DNA's located at each site; all the sites

on the array have the same common reaction or stringency conditions of temperature, buffer, salt concentration, and pH. Any change in the reaction or stringency condition, affects all sites on the array. While sophisticated
5 photolithographic techniques may be used to make an array, or microelectronic sensing elements are incorporated for detection, conventional devices are passive and do not control or influence the actual hybridization process. The active devices of this invention allow each micro-location
10 to function as a completely independent test or analysis site (i.e. they form the equivalent of a "test tube" at each location). Multiple hybridization reactions can be carried out with minimal outside physical manipulations. Additionally, it is unnecessary to change temperatures, to
15 exchange buffers, and the need for multiple washing procedures is eliminated.

Thus, the claimed devices can carry out multi-step and multiplex reactions with complete and precise electronic control, preferably with overall micro-processor
20 control (i.e. run by a computer). The rate, specificity, and sensitivity of multi-step and multiplex reactions are greatly improved at each specific micro-location on the claimed device.

The device also facilitates the detection of
25 hybridized complexes at each micro-location by using an associated optical (fluorescent, chemiluminescent, or spectrophotometric) imaging detector system. Integrated optoelectronic or electronic sensing components which directly detect DNA, can also be incorporated within the
30 device itself.

If desired, a master device addressed with specific binding entities can be electronically replicated or copied to another base device.

This invention may utilize micro-locations of any size or shape consistent with the objective of the invention. In the preferred embodiment of the invention, micro-locations in the sub-millimeter range are used.

5 By "specific binding entity" is generally meant a biological or synthetic molecule that has specific affinity to another molecule, macromolecule or cells, through covalent bonding or non-covalent bonding. Preferably, a specific binding entity contains (either by nature or by
10 modification) a functional chemical group (primary amine, sulfhydryl, aldehyde, etc.), a common sequence (nucleic acids), an epitope (antibodies), a hapten, or a ligand, that allows it to covalently react or non-covalently bind to a common functional group on the surface of a micro-
15 location. Specific binding entities include, but are not limited to: deoxyribonucleic acids (DNA), ribonucleic acids (RNA), synthetic oligonucleotides, antibodies, proteins, peptides, lectins, modified polysaccharides, cells, synthetic composite macromolecules, functionalized
20 nanostructures, synthetic polymers, modified/blocked nucleotides/nucleosides, modified/blocked amino acids, fluorophores, chromophores, ligands, chelates and haptens.

By "stringency control" is meant the ability to discriminate specific and non-specific binding interactions
25 by changing some physical parameter. In the case of nucleic acid hybridizations, temperature control is often used for stringency. Reactions are carried out at or near the melting temperature (T_m) of the particular double-stranded hybrid pair.

30 Thus, the first and most important aspect of the present invention is a device with an array of electronically programmable and self-addressable microscopic locations. Each microscopic location contains

an underlying working direct current (DC) micro-electrode supported by a substrate. The surface of each micro-location has a permeation layer for the free transport of small counter-ions, and an attachment layer for the

5 covalent coupling of specific binding entities. These unique design features provide the following critical properties for the device: (1) allow a controllable functioning DC electrode to be maintained beneath the microlocation; (2) allow electrophoretic transport to be

10 maintained; and (3) separate the affinity or binding reactions from the electrochemical and the adverse electrolysis reactions occurring at the electrode (metal) interfaces. It should be emphasized that the primary function of the micro-electrodes used in these devices is

15 to provide electrophoretic propulsion of binding and reactant entities to specific locations.

By "array" or "matrix" is meant an arrangement of addressable locations on the device. The locations can be arranged in two dimensional arrays, three dimensional

20 arrays, or other matrix formats. The number of locations can range from several to at least hundreds of thousands. Each location represents a totally independent reaction site.

In a second aspect, this invention features a method

25 for transporting the binding entity to any specific micro-location on the device. When activated, a micro-location can affect the free field electrophoretic transport of any charged functionalized specific binding entity directly to itself. Upon contacting the specific micro-location, the

30 functionalized specific binding entity immediately becomes covalently attached to the attachment layer surface of that specific micro-location. Other micro-locations can be simultaneously protected by maintaining them at the

opposite potential to the charged molecules. The process can be rapidly repeated until all the micro-locations are addressed with their specific binding entities.

By "charged functionalized specific binding entity" is meant a specific binding entity that is chemically reactive (i.e., capable of covalent attachment to a location) and carries a net charge (either positive or negative).

In a third aspect, this invention features a method for concentrating and reacting analytes or reactants at any specific micro-location on the device. After the attachment of the specific binding entities, the underlying microelectrode at each micro-location continues to function in a direct current (DC) mode. This unique feature allows relatively dilute charged analytes or reactant molecules free in solution to be rapidly transported, concentrated, and reacted in a serial or parallel manner at any specific micro-locations which are maintained at the opposite charge to the analyte or reactant molecules. Specific micro-locations can be protected or shielded by maintaining them at the same charge as the analytes or reactant molecules. This ability to concentrate dilute analyte or reactant molecules at selected micro-locations greatly accelerates the reaction rates at these micro-locations.

When the desired reaction is complete, the micro-electrode potential can be reversed to remove non-specific analytes or unreacted molecules from the micro-locations.

Specific analytes or reaction products may be released from any micro-location and transported to other locations for further analysis; or stored at other addressable locations; or removed completely from the system.

The subsequent analysis of the analytes at the specific micro-locations is also greatly improved by the ability to repulse non-specific entities from these locations.

- 5 In a fourth aspect, this invention features a method for improving stringency control of nucleic acid hybridization reactions, comprising the steps of:
- rapidly concentrating dilute target DNA and/or probe DNA sequences at specific micro-location(s) where

10 hybridization is to occur;

 - rapidly removing non-specifically bound target DNA sequences from specific micro-location(s) where hybridization has occurred;
 - rapidly removing competing complementary target DNA

15 sequences from specific micro-location(s) where hybridization has occurred;

 - adjusting electronic stringency control (ESC) to remove partially hybridized DNA sequences (more than one base mis-match);

20 -adjusting ESC to improve the resolution of single mis-match hybridizations using probes in the 8-mer to 21-mer range(e.g., to identify point mutations); - using ESC to efficiently hybridize oligonucleotide point mutation probes outside of the ranges used in

25 conventional procedures (e.g., probes longer than 21-mers and shorter than 8-mers);

 - applying independent ESC to individual hybridization events occurring in the same bulk solution and at the same temperature; and

30 -using ESC to improve hybridization of un-amplified target DNA sequences to arrays of capture oligonucleotide probes.

In a fifth aspect, this invention features a method for the combinatorial synthesis of biopolymers at micro-locations.

In a sixth aspect, this invention features a method
5 for replicating a master device.

In a seventh aspect, this invention features a device which electronically carries out sample preparation and transports target DNA to the analytical component of the device.

10 In an eighth aspect, this invention features a device which electronically delivers reagents and reactants with minimal use of fluidics.

In a ninth aspect, this invention features a device which carries out molecular biology and DNA amplification
15 reactions (e.g. restriction cleavage reactions; and DNA/RNA polymerase and DNA ligase target amplification reactions).

In a tenth aspect, this invention features a device which can electronically size and identify restriction fragments (e.g. carry out electronic restriction fragment
20 length polymorphism and DNA finger printing analysis).

In a eleventh aspect, this invention features a device which carries out antibody-antigen and immunodiagnostic reactions.

In a twelveth aspect, this invention features a device
25 which is able to carry out combinatorial synthesis of oligonucleotides and peptides.

In a thirteenth aspect, this invention features a device which selectively binds cells, processes cells for hybridization, removes DNA from cells, or carries out
30 electronic in-situ hybridization within the cells.

In a fourteenth aspect, this invention features methods for detecting and analyzing reactions that have occurred at the addressed micro-locations using self-

addressed microelectronic devices with associated optical, optoelectronic or electronic detection systems or self-addressed microelectronic devices with integrated optical, optoelectronic or electronic detection systems.

5 Because the devices of this invention are active programmable electronic matrices, the acronym "APEX" is used to describe or designate the unique nature of these devices. The APEX acronym is used for both the microlithographically produced "chips" and micro-machined
10 devices.

The active nature of APEX microelectronic devices and chips allows us to create new mechanisms for carrying out a wide variety of molecular biological reactions. These include novel methods for achieving both the linear and
15 exponential multiplication or amplification of target DNA and RNA molecules.

The device provides electronic mechanisms to: (1) selectively denature DNA hybrids in common buffer solutions at room temperature (e.g. well below their T_m points); (2)
20 to rapidly transport or move DNA back and forth between two or more micro-locations; and (3) to selectively concentrate specific reactants, reagents, and enzymes at the desired micro-locations. These all involve new physical parameters for carrying out molecular biological and target
25 amplification type reactions.

A number of examples of electronically controlled molecular biology reactions have been developed, these include: (1) Electronically Directed Restriction Enzyme Cleavage of Specific ds-DNA Sequences; (2) Electronic
30 Restriction Fragment Analysis; (3) Electronic Multiplication of Target DNA By DNA Polymerases; (4) Electronic Ligation and Multiplication of Target DNA Sequences By DNA and RNA Ligases; and (5) Electronic

Multiplication of Target DNA By RNA Polymerases. These examples are representative of the types of molecular biological reactions and procedures which can be carried out on the APEX devices.

- 5 Other features and advantages of the invention will be apparent from the following detailed description of the invention, and from the claims.

Brief Description of the Drawings

FIGURE 1 is the cross-section of three self-
10 addressable micro-locations fabricated using microlithographic techniques.

FIGURE 2 is the cross-section of a microlithographically fabricated micro-location.

FIGURE 3 is a schematic representation of a self-
15 addressable 64 micro-location chip which was actually fabricated, addressed with oligonucleotides, and tested.

FIGURE 4 shows particular attachment chemistry procedure which allows rapid covalent coupling of specific oligonucleotides to the attachment surface of a micro-
20 location.

FIGURE 5 is a blown-up schematic diagram of a micro-machined 96 micro-locations device.

FIGURE 6 is the cross-section of a micro-machined device.

FIGURE 7 shows the mechanism the device uses to electronically concentrate analyte or reactant molecules at a specific micro-location.

FIGURE 8 shows the self-directed assembly of a device with three specific oligonucleotide binding entities (SSO-
30 A, SSO-B, and SSO-C).

FIGURE 9 shows an electronically controlled hybridization process with sample/target DNA being

concentrated at micro-locations containing specific DNA capture sequences.

FIGURE 10 shows an electronically directed serial hybridization process.

5 FIGURE 11 shows the electronic stringency control (ESC) of a hybridization process for determining single point mutations.

FIGURE 12 shows a scheme for the detection of hybridized DNA without using labeled DNA probe, i.e.,
10 electronically controlled fluorescent dye detection process.

FIGURE 13 shows a scheme of electronically controlled replication of devices.

FIGURE 14 shows a scheme of electronically directed
15 combinatorial synthesis of oligonucleotides.

FIGURE 15 shows a graph comparing the results for 15-mer Ras 12 point mutation hybridizations carried out using electronic stringency control and conventional techniques.

FIGURE 16 shows a scheme for electronically controlled
20 restriction fragment cleavage of DNA.

FIGURE 17 shows a scheme for the electronically controlled amplification of DNA using DNA polymerase.

FIGURE 18 shows a diagram of an APEX device which is designed to carry out sample preparation and DNA analysis.

25. Detailed Description of the Invention

The devices and the related methodologies of this invention allow molecular biology and diagnostic reactions to be carried out under "complete electronic control". The meaning of "electronic control" as referred to in this
30 invention goes beyond the conventional connotation of the term. Most conventional microelectronic devices, instruments, and detector systems are always at some level

under electronic control. The microelectronic devices of this invention are not only under conventional electronic control, but more importantly they also provide further direct electronic control over the physical aspects of carrying out molecular biological and diagnostic reactions. The basic concept of this invention is a microelectronic device with programmable and addressable microscopic locations. Each micro-location has a derivatized upper surface for the covalent attachment of specific binding entities (i.e., an attachment layer), an intermediate permeation layer, and an underlying direct current (DC) micro-electrode. After the initial fabrication of the basic microelectronic structure, the device is able to self-direct the addressing of each specific micro-location with specific binding entities. In this sense, the device self-assembles itself. The self-addressed device is subsequently able to actively carry out individual multi-step and combinatorial reactions at any of its micro-locations. The device is able to carry out multiplex reactions, but with the important advantage that each reaction occurs at the equivalent of a truly independent test site. The device is able to electronically direct and control the rapid movement and concentration of analytes and reactants to or from any of its micro-locations. The ability of the device to electronically control the dynamic aspects of various reactions provides a number of new mechanisms and important advantages and improvements.

The concepts and embodiments of this invention are described in three sections. The first section, "Design and Fabrication of the Basic Devices," describes the design of the basic underlying microelectronic device and the fabrication of devices using both microlithographic and micromachining techniques. The second section, "Self-

Directed Addressing of the Devices," describes the self-addressing and self-assembly of the device, specifically the rapid transport and attachment of specific binding entities to each micro-location. The third section, 5 "Applications of the Devices," describes how the device provides electronic control of various multi-step, combinatorial, and multiplex reactions. This section also describes the various uses and applications of the device.

I. Design and Fabrication of the Basic Devices

10 In order for a device to carry out multi-step and multiplex reactions, its electronic components must be able to maintain active operation in aqueous solutions. To satisfy this requirement, each micro-location must have an underlying controllable and functioning DC mode micro- 15 electrode. However, it is important for device performance, particularly sensitivity (signal to noise ratio), that binding and affinity reactions are not affected by the electrolysis reactions occurring on the active DC electrode surfaces. Other considerations for the 20 design and fabrication of a device include, but are not limited to, materials compatibilities, nature of the specific binding entities and the subsequent reactants and analytes, and the number of micro-locations.

By "a controllable and functioning DC mode micro- 25 electrode" is meant a micro-electrode biased either positively or negatively, operating in a direct current mode (either continuous or pulse), which can in a controllable manner affect or cause the free field electrophoretic transport of charged specific binding 30 entities, reactants, or analytes to or from any location on the device, or from the sample solution.

Within the scope of this invention, the free field electrophoretic transport of molecules, is not actually dependent on the electric field produced being bounded or confined by an insulating material. Conventional
5 electrophoretic separation technologies require confinement or enclosure of electric field lines by insulating (non-conducting) materials. In the case of free field
10 electrophoretic transport, charged molecules are moved from one micro-location to any other micro-location, or from the bulk solution to specific micro-locations. Therefore,
special arrangements or confinement by insulating materials is not required for this aspect of the invention.

A device can be designed to have as few as two addressable micro-locations or as many as hundreds of
15 thousands of micro-locations. In general, a complex device with a large number of micro-locations is fabricated using microlithography techniques. Fabrication is carried out on silicon or other suitable substrate materials, such as
glass, silicon dioxide, plastic, or ceramic materials.
20 These microelectronic "chip" designs would be considered large scale array or multiplex analysis devices. A device with a small number of micro-locations or macro-locations would be fabricated using micro-machining techniques.

Addressable micro-locations can be of any shape,
25 preferably round, square, or rectangular. The size of an addressable micro-location can be of any size, preferably range from sub-micron ($\sim 0.5 \mu\text{m}$) to several centimeters (cm), with $5 \mu\text{m}$ to $100 \mu\text{m}$ being the most preferred size range for devices fabricated using microlithographic
30 techniques, and $100 \mu\text{m}$ to 10 millimeters being the most preferred size range for devices fabricated using the micro-machining techniques. To make micro-locations smaller than the resolution of microlithographic methods

would require techniques such as electron beam lithography, ion beam lithography, or molecular beam epitaxy. While microscopic locations are desirable for analytical and diagnostic type applications, larger addressable locations or macro-locations (e.g., larger than 5 mm) are desirable for applications such as, but not limited to, preparative scale biopolymer synthesis, sample preparation, electronically dispensing of reagents.

After micro-locations have been created by using microlithographic and/or micro-machining techniques, chemical modification, polymerization, or even further microlithographic fabrication techniques are used to create the specialized attachment and permeation layers. These important layers separate the binding entities from the metal surface of the electrode. These important structures allow the DC mode micro-electrodes under the surface of each micro-location to: (1) affect or cause the free field electrophoretic transport of specific (charged) binding entities from the surface of one micro-location to the surface of another micro-location, or from the bulk solution to specific micro-locations; (2) concentrate and covalently attach the specific binding entities to the specially modified surface of the specific micro-location; (3) continue to actively function in the DC mode after the attachment of specific binding entities so that other reactants and analytes can be transported in a controlled manner to or from the micro-locations; and (4) not adversely affect the binding or affinity reactions with electrochemical reactions and products.

I(a). Design Parameters (MICROLITHOGRAPHY)

Figure 1 shows a basic design of self-addressable micro-locations fabricated using microlithographic

techniques. The three micro-locations (10) (ML-1, ML-2, ML-3) are formed on the surface of metal sites (12) which have been deposited on an insulator layer/base material. The metal sites (12) serve as the underlying micro-
5 electrode structures (10). An insulator material separates the metal sites (12) from each other. Insulator materials include, but are not limited to, silicon dioxide, silicon nitride, glass, resist, polyimide, rubber, plastic, or ceramic materials.

10 Figure 2 shows the basic features of an individual micro-location (10) formed on a microlithographically produced metal site (12). The addressable micro-location is formed on the metal site (12), and incorporates an oxidation layer (20), a permeation layer (22), an
15 attachment layer (24), and a binding entity layer (26). The metal oxide layer provides a base for the covalent coupling of the permeation layer. Metal oxide and hydroxyl groups (either alone or in combination), and other materials known to those skilled in the art of surface
20 coating chemistries may provide covalent sites from which to construct or hold the permeations layer. It is not absolutely essential that the permeation layer actually be covalently attached to the metal electrode surface. The physical overlaying of permeable materials represents an
25 alternative method which is within the scope of this invention.

The permeation layer provides spacing between the metal surface and the attachment/binding entity layers and allows solvent molecules, small counter-ions, and
30 electrolysis reaction gases to freely pass to and from the metal surface. It is possible to include within the permeation layer substances which can reduce the adverse physical and chemical effects of electrolysis reactions,

including, but not limited to, redox reaction trapping substances, such as palladium for H₂, and iron complexes for O₂ and peroxides. The thickness of the permeation layer for microlithographically produced devices can range
5 from approximately 1 nanometers (nm) to 100 microns (μm), with 2 nm to 10 μm being the most preferred.

The attachment layer provides a base for the covalent binding of the binding entities. The thickness of the attachment layer for microlithographically produced devices
10 can range from 0.5 nm to 5 μm, with 1 nm to 500 nm being the most preferred. In some cases, the permeation and attachment layers can be formed from the same material. Certain permeation layer materials which can be further activated for the coupling of binding entities are included
15 within the scope of this invention.

The specific binding entities are covalently coupled to the attachment layer, and form the specific binding entity layer. Ideally, the specific binding entity layer is usually a mono-layer of the specific binding molecules.
20 However, in some cases the binding entity layer can have several or even many layers of binding molecules.

Certain design and functional aspects of the permeation and attachment layer are dictated by the physical (e.g., size and shape) and chemical properties of
25 the specific binding entity molecules. They are also dictated to some extent by the physical and chemical properties of the reactant and analyte molecules, which will be subsequently transported and bound to the micro-locations. For example, oligonucleotide binding entities
30 can be attached to one type of a micro-location surface without causing a loss of the DC mode function, i.e., the underlying micro-electrode can still cause the rapid free field electrophoretic transport of other analyte molecules

to or from the surface to which the oligonucleotide binding entities are attached. However, if large globular protein binding entities (e.g., antibodies) are attached to the same type of surface, they might insulate the surface and
5 cause a decrease or a complete loss of the DC mode function. Appropriate modification of the attachment layer would have to be carried out so as to either reduce the number of large binding entities (e.g., large globular proteins) or provide spacing between the binding entities
10 on the surface.

The spacing between micro-locations is determined by the ease of fabrication, the requirement for detector resolution between micro-locations, and the number of micro-locations desired on a device. However, particular
15 spacings between micro-locations, or spacial arrangement or geometry of the micro-locations is not necessary for device function, in that any combination of micro-locations (i.e., underlying micro-electrodes) can operate over the complete device area. Nor is it actually necessary to enclose the
20 device or completely confine the micro-locations with dielectric or insulating barriers. This is because complex electronic field patterns or dielectric boundaries are not required to selectively move, separate, hold, or orient specific molecules in the space or medium between any of
25 the electrodes. The device accomplishes this by attaching the specific binding molecules and subsequent analytes and reactants to the surface of an addressable micro-location. Free field electrophoretic propulsion provides for the rapid and direct transport of any charged molecule between
30 any and all locations on the device; or from the bulk solution to microlocations. However, it should be pointed out that the devices would be enclosed for fluid containment and for bio-hazard purposes.

As the number of micro-locations increases beyond several hundred, the complexity of the underlying circuitry of the micro-locations increases. In this case the micro-location grouping patterns have to be changed and spacing
5 distances increased proportionally, or multi-layer circuitry can be fabricated into the basic device.

In addition to micro-locations which have been addressed with specific binding entities, a device will contain non-analytical micro-locations and macro-locations
10 which serve other functions. These micro-locations or macro-locations can be used to store reagents, to temporarily hold reactants, analytes, or cells; and as disposal units for excess reactants, analytes, or other
15 interfering components in samples (i.e., reagent dispensing and sample preparation systems). Other un-addressed micro-locations can be used in combination with the addressed
micro-locations to affect or influence the reactions that are occurring at these specific micro-locations. These
20 micro-locations add to both inter-device and intra-device activity and control. Thus, it is also possible for the
micro-locations to interact and transport molecules between two separate devices. This provides a mechanism for
loading a working device with binding entities or reactants from a storage device, for sample preparations and for
25 copying or replicating a device.

Figure 3 shows a matrix type device containing 64 addressable micro-locations (30). A 64 micro-location device is a convenient design, which fits with standard microelectronic chip packaging components. Such a device
30 is fabricated on a silicon chip substrate approximately 1.5 cm x 1.5 cm, with a central area approximately 750 μm x 750 μm containing the 64 micro-locations. Each micro-location (32) is approximately 50 μm square with 50 μm spacing

between neighboring micro-locations. Connective circuitry for each individual underlying micro-electrode runs to an outside perimeter (10 mm x 10 mm) of metal contact pads (300 μm square) (34). A raised inner perimeter can be
5 formed between the area with the micro-locations and the contact pads, producing a cavity which can hold approximately 2 to 10 microliters (μl) of a sample solution. The "chip" can be mounted in a standard quad package, and the chip contact pads (34) wired to the quad package pins.
10 Systems containing more than one chip and additional packaging and peripheral components may be designed to address problems related to clinical diagnostics, i.e., addition of sample materials, fluid transfer, and containment of bio-hazardous materials. The packaged chip
15 can then be plugged into a microprocessor controlled DC power supply and multimeter apparatus which can control and operate the device. It is contemplated by this invention that device manufacture (prior to addressing) will ultimately involve the incorporation of three basic
20 components which would be essentially sandwiched together. The basic chip device to which the binding entities are attached, would be in the middle position; a sample or fluid containment component, would be annealed over the top of the basic chip device; and a microelectronic detector
25 and on board controller component would be annealed to the bottom of the basic chip device. This strategy solves a number of problems related to fabrication techniques and materials compatibilities.

I(b). Microolithography Fabrication Procedures

30 I(b)(1) Fabrication Steps

General microlithographic or photolithographic techniques can be used for the fabrication of the complex

"chip" type device which has a large number of small micro-locations. While the fabrication of devices does not require complex photolithography, the selection of materials and the requirement that an electronic device function actively in aqueous solutions does require special considerations.

The 64 micro-location device (30) shown in Figure 3 can be fabricated using relatively simple mask design and standard microlithographic techniques. Generally, the base substrate material would be a 1 to 2 centimeter square silicon wafer or a chip approximately 0.5 millimeter in thickness. The silicon chip is first overcoated with a 1 to 2 μm thick silicon dioxide (SiO_2) insulation coat, which is applied by plasma enhanced chemical vapor deposition (PECVD).

In the next step, a 0.2 to 0.5 μm metal layer (e.g., aluminum) is deposited by vacuum evaporation. It is also possible to deposit metals by sputtering techniques. In addition to aluminum, suitable metals and materials for circuitry include gold, silver, tin, titanium, copper, platinum, palladium, polysilicon, carbon, and various metal combinations. Special techniques for ensuring proper adhesion to the insulating substrate materials (SiO_2) are used with different metals. Different metals and other materials may be used for different conductive components of the device, for example, using aluminum for the perimeter contact pads, polysilicon for the interconnect circuitry, and a noble metal (gold or platinum) for the micro-electrodes.

The chip is next overcoated with a positive photoresist (Shipley, Microposit AZ 1350 J), masked (light field) with the circuitry pattern, exposed and developed. The photosolubilized resist is removed, and the exposed

aluminum is etched away. The resist island is now removed, leaving the aluminum circuitry pattern on the chip. This includes an outside perimeter of metal contact pads, the connective circuitry (wires), and the center array of
5 micro-electrodes which serve as the underlying base for the addressable micro-locations.

Using PECVD, the chip is overcoated first with a 0.2 to 0.4 micron layer of SiO_2 , and then with a 0.1 to 0.2 micron layer of silicon nitride (Si_3N_4). The chip is then
10 covered with positive photoresist, masked for the contact pads and micro-electrode locations, exposed, and developed. Photosolubilized resist is removed, and the SiO_2 and Si_3N_4 layers are etched away to expose the aluminum contact pads and micro-electrodes. The surrounding island resist is
15 then removed, the connective wiring between the contact pads and the micro-electrodes remains insulated by the SiO_2 and Si_3N_4 layers.

The SiO_2 and Si_3N_4 layers provide important properties for the functioning of the device. The second SiO_2 layer
20 provides better contact and improved sealing with the aluminum circuitry. It is also possible to use resist materials to insulate and seal. This prevents undermining of the circuitry due to electrolysis effects when the micro-electrodes are operating. The final surface layer
25 coating of Si_3N_4 is used because it has much less reactivity with the subsequent reagents used to modify the micro-electrode surfaces for the attachment of specific binding entities.

I(b) (2) Permeation and Attachment Layer Formation Steps

30 At this point the micro-electrode locations on the device are ready to be modified with a specialized permeation and attachment layer. This is an important

aspect of the invention. The objective is to create on the micro-electrode an intermediate permeation layer with selective diffusion properties and an attachment surface layer with optimal binding properties.

5 Optimally, the attachment layer has from 10^5 to 10^7 functionalized locations per square micron (μm^2) for the attachment of specific binding entities. The attachment of specific binding entities should not overcoat or insulate the surface so as to prevent the underlying micro-electrode
10 from functioning. A functional device requires some fraction (~ 5% to 25%) of the actual metal micro-electrode surface to remain accessible to solvent (H_2O) molecules, and to allow the diffusion of counter-ions (e.g., Na^+ and Cl^-) and electrolysis gases (e.g., O_2 and H_2) to occur.

15 The intermediate permeation layer is also designed to allow diffusion to occur. Additionally, the permeation layer should have a pore limit property which inhibits or impedes the larger binding entities, reactants, and analytes from physical contact with the micro-electrode
20 surface. The permeation layer keeps the active micro-electrode surface physically distinct from the binding entity layer of the micro-location.

This design allows the electrolysis reactions required for electrophoretic transport to occur on micro-electrode
25 surface, but avoids adverse electrochemical effects to the binding entities, reactants, and analytes.

The permeation layer can also be designed to include substances which scavenge adverse materials produced in the electrolysis reactions (H_2 , O_2 , free radicals, etc.). A
30 sub-layer of the permeation layer may be designed for this purpose.

A variety of designs and techniques can be used to produce the permeation layer. The general designs include: (1) "Lawns", (2) "Meshes", and (3) "Porous" structures.

Lawn type permeation layers involve the arrangement of
5 linear molecules or polymers in a vertical direction from the metal surface, in a way resembling a thick lawn of grass. These structures can be formed by attaching linear or polymeric hydrophilic molecules directly to the metal surface, with minimum cross linkages between the vertical
10 structures. Ideally these hydrophilic linear molecules are bifunctional, with one terminal end suited for covalent attachment to the metal pad, and the other terminal end suited for covalent attachment of binding entities.

Mesh type permeation layers involve random
15 arrangements of polymeric molecules which form mesh like structures having an average pore size determined by the extent of cross-linking. These structures can be formed by hydrogel type materials such as, but not limited to polyacrylamide, agarose, and a variety of other biological
20 and non-biological materials which can be polymerized and cross-linked.

Pore type permeation layers involve the use of materials which can form a channel or hole directly from the top surface of the layer to the metal pad, including,
25 but not limited to, polycarbonates, polysulfone, or glass materials. In all cases the permeation layer must be secured either physically or chemically to the metal surface, and must contain functional groups or be capable of being functionalized for the attachment of binding
30 entities to its surface.

One preferred procedure which produces a lawn type structure involves the derivatization of the metal micro-electrode surface uses aminopropyltriethoxy silane (APS).

APS reacts readily with the oxide and/or hydroxyl groups on metal and silicon surfaces. APS provides a combined permeation layer and attachment layer, with primary amine groups for the subsequent covalent coupling of binding
5 entities. In terms of surface binding sites, APS produces a relatively high level of functionalization (i.e., a large number of primary amine groups) on slightly oxidized aluminum surfaces, an intermediate level of functionalization on SiO₂ surfaces, and very limited
10 functionalization of Si₃N₄ surfaces.

The APS reaction is carried out by treating the whole device (e.g., a chip) surface for 30 minutes with a 10% solution of APS in toluene at 50°C. The chip is then washed in toluene, ethanol, and then dried for one hour at
15 50°C. The micro-electrode metal surface is functionalized with a large number of primary amine groups (10⁵ to 10⁶ per square micron). Binding entities can now be covalently bound to the derivatized micro-electrode surface. The depth of this "Lawn Type" permeation layer may be increased
20 by using polyoxyethylene bis(amine), bis(polyoxyethylene bis(amine)), and other polyethylene glycols or similar compounds.

The APS procedure works well for the attachment of oligonucleotide binding entities. Figure 4 shows the
25 mechanism for the attachment of 3'-terminal aldehyde derivatized oligonucleotides (40) to an APS functionalized surface (42). While this represents one of the approaches, a variety of other approaches for forming permeation and attachment layers are possible. These include the use of
30 self-directed addressing by the base electrode itself to: (1) form secondary metal layers by electroplating to the base micro-electrode; (2) to form permeation layers by electropolymerization to the micro-electrode location, or

(3) to transport by the free field electrophoresis process activated polymers and reagents to the micro-electrode surface to form subsequent permeation and attachment layers.

5 I(c). Micro-Machined Device Design and Fabrication

This section describes how to use micro-machining techniques (e.g., drilling, milling, etc.) or non-lithographic techniques to fabricate devices. In general, these devices have relatively larger micro-locations (> 100
10 microns) than those produced by microlithography. These devices can be used for analytical applications, as well as for preparative type applications, such as biopolymer synthesis, sample preparation, reagent dispenser, storage locations, and waste disposal. Large addressable locations
15 can be fabricated in three dimensional formats (e.g., tubes or cylinders) in order to carry a large amount of binding entities. Such devices can be fabricated using a variety of materials, including, but not limited to, plastic, rubber, silicon, glass (e.g., microchannelled,
20 microcapillary, etc.), or ceramics. Low fluorescent materials are more ideal for analytical applications. In the case of micro-machined devices, connective circuitry and larger electrode structures can be printed onto materials using standard circuit board printing techniques
25 known to those skilled in the art.

Addressable micro-location devices can be fabricated relatively easily using micro-machining techniques. Figure 5 is a schematic of a representative 96 micro-location device. This micro-location device is fabricated from a
30 suitable material stock (2 cm x 4 cm x 1 cm), by drilling 96 proportionately spaced holes (1 mm in diameter) through the material. An electrode circuit board (52) is formed on

a thin sheet of plastic material stock, which fits precisely over the top of the micro-location component (54). The underside of the circuit board contains the individual wires (printed circuit) to each micro-location (55). Short platinum electrode structures (~ 3-4 mm) (62) are designed to extend down into the individual micro-location chambers (57). The printed circuit wiring is coated with a suitable water-proof insulating material. The printed circuit wiring converges to a socket, which allows connection to a multiplex switch controller (56) and DC power supply (58). The device is partially immersed and operates in a common buffer reservoir (59).

While the primary function of the micro-locations in devices fabricated by micro-machining and microlithography techniques is the same, their designs are different. In devices fabricated by microlithography, the permeation and attachment layers are formed directly on the underlying metal micro-electrode. In devices fabricated by micro-machining techniques, the permeation and attachment layers are physically separated from their individual metal electrode structure (62) by a buffer solution in the individual chamber or reservoir (57) (see Figure 6). In micro-machined devices the permeation and attachment layers can be formed using functionalized hydrophilic gels, membranes, or other suitable porous materials.

In general, the thickness of the combined permeation and attachment layers ranges from 10 μm to 30 μm . For example, a modified hydrophilic gel of 20% to 35 % polyacrylamide (with 0.1% polylysine), can be used to partially fill (~ 0.5 mm) each of the individual micro-location chambers in the device. These concentrations of gel form an ideal permeation layer with a pore limit of from 2 nm to 10 nm. The polylysine incorporated into the

gel provides primary amine functional groups for the subsequent attachment of specific binding entities. This type of gel permeation layer allows the electrodes to function actively in the DC mode. When the electrode is activated, the gel permeation layer allows small counterions to pass through it, but the larger specific binding entity molecules are concentrated on the outer surface. Here they become covalently bonded to the outer layer of primary amines, which effectively becomes the attachment layer.

An alternative technique for the formation of the permeation and attachment layers is to incorporate into the base of each micro-location chamber a porous membrane material. The outer surface of the membrane is then derivatized with chemical functional groups to form the attachment layer. Appropriate techniques and materials for carrying out this approach are known to those skilled in the art.

The above descriptions for the design and fabrication of both the microlithographic and micromachined devices should not be considered as a limit to other variations or forms of the basic device. Many variations of the device with larger or smaller numbers of addressable micro-locations or combinations of devices can be for different analytical and preparative applications. Variations of the device with larger addressable locations can be designed for preparative biopolymer synthesis applications, sample preparation, cell sorting systems, in-situ hybridization, reagent dispensers, storage systems, and waste disposal systems.

II. Self-Directed Addressing of the Devices

The devices of this invention are able to electronically self-address each micro-location with a specific binding entity. The device itself directly
5 affects or causes the transport of a charged specific binding entity to a specific micro-location. The binding entities are generally functionalized so that they readily react and covalently bond to the attachment layer. The device self-assembles in the sense that no outside process,
10 mechanism, or equipment is needed to physically direct, position, or place a specific binding entity at a specific micro-location. This self-addressing process is both rapid and specific, and can be carried out in either a serial or parallel manner.

15 A device can be serially addressed with specific binding entities by maintaining the selected micro-location in a DC mode and at the opposite charge (potential) to that of a specific binding entity. If a binding entity has a net negative charge, then the micro-location to which the
20 binding entity is to be transported would be biased positive. Conversely, a negatively charged micro-location would be used to transport a positively charged binding entity. Options for biasing the remaining micro-locations in the serial addressing process include: biasing all other
25 micro-locations at the opposite charge (counter to the micro-location being addressed); biasing a limited group of micro-locations at the opposite charge; or biasing just one micro-location (or other electrode) at the opposite charge. In some cases, it will be desirable to strongly bias one or
30 more micro-locations at the opposite charge, while other groups of micro-locations are biased only weakly. This process allows previously addressed micro-locations to be protected during the addressing of the remaining micro-

locations. In cases where the binding entity is not in excess of the attachment sites on the micro-location, it may be necessary to activate only one other micro-electrode to affect the free field electrophoretic transport to the specific micro-location. Specific binding entities can be rapidly transported through the bulk solution, and concentrated directly at the specific micro-location(s) where they immediately become covalently bonded to the special surface of the attachment layer. Transportation rates are dependent on the size and charge of the binding entities, and the voltage and current levels used between the micro-locations. In general, transportation rates can range from several seconds to several minutes. The ability to electronically concentrate binding entities, reactants, or analytes (70) on a specific micro-location (72) is shown in Figure 7. All other micro-locations can be protected and remain unaffected during the specific binding entity addressing process. Any unreacted binding entity is removed by reversing the polarity of that specific micro-location, and electrophoresing it to a disposal location. The cycle is repeated until all desired micro-locations are addressed with their specific binding entities. Figure 8 shows the serial process for addressing specific micro-locations (81, 83, 85) with specific oligonucleotide binding entities (82, 84, 86).

The parallel process for addressing micro-locations involves simultaneously activating more than one micro-location (a particular group) so that the same specific binding entity is transported, concentrated, and reacted with more than one specific micro-location. The subsequent parallel processing is similar to the serial process.

III. Applications of the Devices

Once a device has been self-addressed with specific binding entities, a variety of molecular biology type multi-step and multiplex reactions and analyses can be carried out on the device. The devices of this invention are able to electronically provide active and dynamic control over a number of important reaction parameters. This electronic control leads to new physical mechanisms for controlling reactions, and significant improvements in reaction rates, specificities, and sensitivities. The improvements in these parameters come from the ability of the device to electronically control and directly affect: (1) the rapid transport of reactants or analytes to a specific micro-location containing attached specific binding entities; (2) an increase in reaction rate due to the concentration of reactants or analytes with the specific binding entities on the surface of the specific micro-location; (3) the rapid and selective removal of unreacted and non-specifically bound components from the micro-location; and (4) the stringency for optimal binding conditions.

The self-addressed devices of this invention are able to rapidly carry out a variety of micro-formatted multi-step and/or multiplex reactions and procedures; which include, but are not limited to:

- DNA and RNA hybridizations procedures and analysis in conventional formats; e.g., attached target DNA/probe DNA, attached probe DNA/target DNA, attached capture DNA/target DNA/probe DNA;
- multiple or multiplexed hybridization reactions in both serial and parallel fashion;
- restriction fragment and general DNA/RNA fragment size analysis;

- molecular biology reactions, e.g., restriction enzyme reactions and analysis, ligase reactions, kinasing reactions, and DNA/RNA amplification;
- antibody/antigen reactions involving large or small antigens and haptens;
- diagnostic assays, e.g., hybridization analysis (including in-situ hybridization), gene analysis, fingerprinting, and immunodiagnostics;
- sample preparation, cell sorting, selection, and analysis;
- biomolecular conjugation procedures (i.e. the covalent and non-covalent labeling of nucleic acids, enzymes, proteins, or antibodies with reporter groups, including fluorescent, chemiluminescent, colorimetric, and radioisotopic labels);
- biopolymer synthesis, e.g., combinatorial synthesis of oligonucleotides or peptides;
- water soluble synthetic polymer synthesis, e.g., carbohydrates or linear polyacrylates; and
- macromolecular and nanostructure (nanometer size particles and structures) synthesis and fabrication.

III(a) Nucleic Acid Hybridization

Nucleic acid hybridizations are used as main examples of this invention because of their importance in diagnostics, and because they characterize one of the more difficult types of binding (affinity) reactions. This is particularly true when they are carried out in multiplex formats, where each individual hybridization reaction requires a different stringency condition.

The claimed device and methods allow nucleic acid hybridization to be carried out in a variety of conventional and new formats. The ability of the device to electronically control reaction parameters greatly improves nucleic acid hybridization analysis, particularly the ability of the device to provide electronic stringency control (ESC) to each individual micro-location on an array. In essence, this allows each individual hybridization reaction on a common array to be carried out as a single test tube assay.

The term "nucleic acid hybridization" is meant to include all hybridization reactions between all natural and synthetic forms and derivatives of nucleic acids, including: deoxyribonucleic acid (DNA), ribonucleic acid (RNA), polynucleotides and oligonucleotides.

Conventional hybridization formats, such as "dot blot" hybridization and "sandwich" hybridization, can be carried out with the claimed device as well as large scale array or matrix formats.

As an example, an APEX device for DNA hybridization analysis is designed, fabricated, and used in the following manner. Arrays of micro-locations are first fabricated using microlithographic (or micromechining) techniques. The number of addressable micro-locations on an array depends on the final use. The device is rapidly self-addressed in a serial manner with a group of specific oligonucleotides. In this case, the specific oligonucleotides are 3'-terminal aldehyde functionalized oligonucleotides in the range of 6-mers to 100-mers, larger polynucleotides can be attached if desired. The aldehyde functional group allows for covalent attachment to the specific micro-location attachment surface (see Figure 4). This group of specific oligonucleotides can be readily

synthesized on a conventional DNA synthesizer using conventional techniques. The synthesis of each specific oligonucleotide is initiated from a ribonucleotide controlled pore glass (CPG) support. Thus, the 3'-terminal position contains a ribonucleotide, which is then easily converted after synthesis and purification to a terminal dialdehyde derivative by periodate oxidation. The aldehyde containing oligonucleotides (40) will react readily with the primary amine functional groups on the surface of micro-locations by a Schiff's base reaction process.

The electronic addressing of the device with specific oligonucleotides is shown in Figure 8. The addressing of the first specific micro-location (ML-1) (81) with its specific sequence oligonucleotide (SSO-1) (82) is accomplished by maintaining the specific microelectrode (ML-1) at a positive DC potential, while all other microelectrodes are maintained at a negative potential (Fig. 8(A)). The aldehyde functionalized specific sequence (SSO-1) in aqueous buffered solution is free field electrophoresed to the ML-1 address, where it concentrates ($> 10^6$ fold) and immediately becomes covalently bound to the surface of ML-1 (81). All other microelectrodes are maintained negative, and remain protected or shielded from reacting with SSO-1 sequence (82). The ML-1 potential is then reversed to negative (-) to electrophorese any unreacted SSO-1 to a disposal system. The cycle is repeated, SSO-2 (84) ---> ML-2 (83), SSO-3 (86) ---> ML-3 (85), SSO-n ---> ML-n until all the desired micro-locations are addressed with their specific DNA sequences (Fig. 8(D)).

Another method for addressing the device is to transport specific binding entities such as specific oligonucleotides from an electronic reagent supply device.

This supply device would hold a large quantity of binding entities or reagents and would be used to load analytical devices. Binding entities would be electronically transported between the two devices. This system
5 eliminates the need for physical manipulations, such as micro-pipetting, and for complicated fluidic delivery systems within or between devices.

Yet another method for addressing the device is to carry out the combinatorial synthesis of the specific
10 oligonucleotides at the specific micro-locations.

Combinatorial synthesis is described in a later section. After the device is addressed with specific DNA sequences, it is important that the micro-electrodes
15 beneath the micro-locations on the array device remain as independent working direct current (DC) electrodes. This is made possible because the attachment to the electrode surface is carried out in such a manner that the underlying micro-electrode does not become chemically or physically insulated. Each micro-electrode can still produce the
20 strong direct currents necessary for the free field electrophoretic transport of other charged DNA molecules to and from the micro-location surface. Thus, the DNA array device provides complete electronic control over all aspects of the DNA hybridization and any other subsequent
25 reactions.

An example of an electronically controlled hybridization process is shown in Figure 9. In this case, each addressable micro-location has a specific capture sequence (90). A sample solution containing target DNA
30 (92) is applied to the device. All the micro-locations are activated and the sample DNA is concentrated at the micro-locations (Fig. 9(B)). Target DNA molecules from the dilute solution become highly concentrated at the micro-

locations, allowing very rapid hybridization to the specific complementary DNA sequences on the surface. Reversal of the micro-electrode potential repels all un-hybridized DNA from the micro-locations, while the target DNA remains hybridized (Fig. 9(C)). In similar fashion, reporter probes are hybridized in subsequent steps to detect hybridized complexes.

The electronic control of the hybridization process significantly improves the subsequent detection of the target DNA molecules by enhancing the overall hybridization efficiency and by removing non-specific DNA from the micro-location areas. It is expected that 10,000 to 100,000 copies of target sequences in un-amplified genomic DNA will be detectable. Hybridization reactions of this type can be carried out in several minutes or less, under isothermal conditions well below the T_m of the probes; and with minimal outside manipulations (i.e., conventional washing steps are completely eliminated).

Another common format for DNA hybridization assays involves having target DNAs immobilized on a surface, and then hybridizing specific probes to these target DNAs. This format can involve either the same target DNAs at multiple locations, or different target DNAs at specific locations. Figure 10 shows an improved version of this serial hybridization format. In this case micro-locations (101-107) are addressed with different capture DNAs. These are hybridized in a serial fashion with different sequence specific oligonucleotides (108,109). The micro-locations are sequentially biased positive to transport molecules to itself and then biased negative to transport molecules to the next micro-location. At the proper electrode potential, the specifically hybridized DNA probes will remain at that micro-location, while un-hybridized probes

are transported to the next micro-location. The sequence specific oligonucleotide probes can be labeled with a suitable reporter group such as a fluorophore.

The claimed device is able to provide electronic stringency control. Stringency control is necessary for hybridization specificity, and is particularly important for resolving one base mis-matches in point mutations. Figure 11 shows how electronic stringency control can be used for one base mis-match analysis. Electronic stringency control can also be applied to multiple-base mis-match analysis. In Figure 11(A) the perfectly matched DNA hybrid (110) is slightly more stable than mis-matched DNA (112) hybrid. By biasing the micro-locations negative (Fig. 11(B)) and delivering a defined amount of electrophoretic power in a given time, it is possible to denature or remove the mis-matched DNA hybrids while retaining the perfectly matched DNA hybrids (Fig. 11(C)). Figure (15) compares the results for an electronic hybridization process utilizing electronic stringency control with a conventional hybridization process. The hybridization involves 15-mer G and A point mutation probes for the Ras 12 oncogene mutation. The electronic hybridization result show greatly improved hybridization efficiency and a very large discrimination ratio for the one base mis-match over the conventional procedure.

In a further refinement, the claimed device provides independent stringency control to each specific hybridization reaction occurring on the device. In effect each hybridization is a an independent reaction. With a conventional or passive array format, it is impossible to achieve optimal stringency for all the hybridization events which are occurring in the same hybridization solution. However, the active array devices of this invention are

able to provide different electronic stringency to hybridizations at different micro-locations, even though they are occurring in the same bulk hybridization solution. This attribute overcomes the inherent limitation to
5 conventional matrix or array hybridization formats, sequencing by hybridization (SBH) formats, and other multiplex analyses.

In addition to improving the specificity (i.e., discrimination ratio) and sensitivity for hybridization
10 (such as single point mutations detection), electronic stringency control allows oligonucleotides outside the normal size range to be used in these applications. Oligonucleotide sequences ranging from 8-mer to 21-mer are considered acceptable for point mutation detection with
15 conventional hybridization procedures. In the current practice using conventional hybridization procedures, oligonucleotides in the 10-mer to 19-mer are used most frequently in these conventional procedures which utilize temperature and salt concentration for stringency control.
20 Oligonucleotides shorter than 10-mers have been found to be not acceptable for multiplex hybridizations; and sequences shorter than 8-mers are not even considered for use because of poor hybridization efficiencies. Sequences longer than 21-mers are not used because they have very poor
25 discrimination ratios between the match and mismatch probes. As the sequence length goes beyond a 21-mer, the ability to distinguish the difference in the hybridization signals between the match and mis-match probes is greatly reduced.

30 We have found that hybridizations carried out on APEX devices with electronic stringency control allows both shorter (7-mer and shorter) and longer (22-mer and longer) oligonucleotides to be used with very high discrimination

ratios. The use of shorter oligonucleotide sequences (7-mer and less) has advantages for sequencing by hybridization (SBH). Shorter length sequences allow arrays with a smaller number of oligonucleotides (8-mers = 5 65,536, 7-mers = 16,384, 6-mers = 4,096) to be used for this SBH applications. The use of longer sequences (22-mer and longer) with electronic stringency control allows more sensitive and selective point mutation analysis to be carried out. The use of longer probes provides higher 10 sensitivity in DNA samples with high complexity, and also higher overall hybridization efficiencies.

Electronic hybridization techniques can be used to carry out in-situ hybridizations. In-situ represent a fundamentally different hybridization format in that target 15 DNA (or RNA) is not removed from cells, but detected directly inside them. In-situ hybridization procedures are generally complex and time consuming, and the detection of short target sequences (i.e. single point mutations) is nearly impossible. Electronic controlled in-situ 20 hybridizations can be carried out on an APEX device that attaches and processes cells directly on the active surface of the device (see Example 14 concerning sample preparation techniques). However, rather than extracting DNA from the cells, the APEX device electronically hybridizes reporter 25 probes directly to the DNA within the cells. Electronic stringency control is used to increase both selectivity and sensitivity by eliminating much of the non-specific binding and improving overall hybridization efficiency..

The ability to provide electronic stringency control 30 to hybridizations also provides new mechanisms for detecting DNA hybridization without using a reporter group labeled DNA probe. It provides a way to carry out a more direct detection of the hybridization process itself. A

fluorescent dye detection process is shown in Figure 12 and described in Examples 4 and 6. Direct detection of DNA hybrids can be achieved by using DNA binding dyes such as ethidium bromide. The dye binds to both double-stranded and single-stranded DNA but with a greater affinity for the former. In Figure 12(B) positively charged dye (122) is transported to negatively biased micro-locations. The dye binds to both hybridized (120) and un-hybridized (121) DNA sequences (Fig. 12(C)). By biasing the micro-locations positive and delivering a defined amount of power in a given amount of time, the dye molecules bound to un-hybridized micro-locations is selectively removed. A proper amount of potential can be applied which does not adversely affect the DNA hybrids. The hybridized DNAs with associated dye molecules are then fluorescently detected using associated or integrated optical systems.

The following reiterates important advantages the devices of this invention provide for nucleic acid hybridization reactions and analysis:

- (1) The rapid transport of dilute target DNA and/or probe DNA sequences to specific micro-location(s) where hybridization is to occur. This process can take place in the range of 5 to 120 seconds.
- (2) Concentrating dilute target DNA and/or probe DNA sequences at specific micro-location(s) where hybridization is to occur. The concentrating effect can be well over a million fold ($> 10^6$).
- (3) The rapid removal of non-specifically bound target DNA sequences from specific micro-location(s) where hybridization has occurred. This process can take place in the range of 5 to 120 seconds.
- (4) Rapid removal of competing complementary target DNA sequences from specific micro-location(s)

where hybridization has occurred. This process can take place in the range of 5 to 120 seconds.

- 5 (6) The ability to carry out a large number of independent hybridization reactions in a matter of minutes.
- (7) The ability to carry out a hybridization process at isothermal conditions well below the T_m of the probes, and with minimal outside manipulations or washing steps.
- 10 (8) The use of electronic stringency control (ESC) to remove partially hybridized DNA sequences.
- (9) The ability to carry out hybridization analysis of un-amplified genomic target DNA sequences in the 1000 to 100,000 copy range.
- 15 (10) The use of ESC to improve the discrimination ratio (i.e., resolution) and sensitivity of single base mis-match hybridizations (point mutations).
- (11) The ability to use single point mutation probes
20 that are either shorter (7-mer and less) or longer (22-mer or greater) than those used in conventional hybridization procedures.
- (12) The use of ESC to provide individual stringency control in matrix hybridizations.
- 25 (13) Improving the detection of hybridization event by removing non-specific background components.
- (14) The ability to carry out electronic in-situ hybridization on fixed cells.
- 30 (15) The development of a detection method which eliminates the need for using covalently labeled reporter probes or target DNA to detect hybridization.

III(b) Reproduction of Devices

In addition to separately addressing individual devices with specific binding entities, it is also possible to produce a master device, which can copy specific binding entities to other devices. This represents another method for the production or manufacture of devices. The process for the replication of devices is shown in Figure 13. A master device containing micro-locations which have been addressed with specific binding sequences is hybridized with respective complementary DNA sequences (130). These complementary sequences are activated and thus capable of covalent binding to the micro-location attachment layer.

An unaddressed sister device (132) containing an attachment layer is aligned with the hybridized master device (Fig. 13(B)). The master device micro-locations are biased negative and the sister device micro-locations are biased positive. The DNA hybrids are electronically denatured and are transported to the sister device, where the activated DNA sequence binds covalently to the micro-location (Fig. 13(C)). The process can be performed in parallel or in series, depending on the device geometry so that crosstalk between the micro-locations is minimized. The hybrids can be denatured by applying a sufficient negative potential or by using a positively charged chaotropic agent or denaturant.

III(c) Component Devices and Integrated APEX Systems

A number of separate APEX devices or chips can be combined to form an integrated APEX System. Because APEX type devices can carry out many different functions, and reactants can be moved between devices by free field electrophoresis, integrated systems can be developed. For example, separate APEX devices or chips which: (1)

selectively bind and lyse cells, (2) electronically dispense reagents, (3) carry out pre-hybridizations, (4) act as waste disposal units, (5) provide storage for DNA fragments, and (5) carry out hybridization analysis can be
5 combined to form a sample preparation and hybridization analysis system (see Example 14 and Figure 19). These integrated APEX microelectronic systems are the equivalent of complete clinical analyzers or programmable molecular biology laboratories (i.e. laboratories on a chip).
10 However, they go beyond automation (robotics) or other microanalytical devices in that they require minimal fluidics or physical manipulation of samples, reagents, and reactants. Additional types of integrated APEX systems would include , but are limited to, those which could carry
15 out in-situ hybridizations, cell selector and processor systems, and immunodiagnostic analyzers.

III(d) Detection System and Reporter Groups

In the case of binding reactions involving fluorescent labelled reporter groups, it is possible to use an
20 epifluorescent type microscope detection system for the analysis of the binding reactions on APEX devices. The overall sensitivity of the system depends on the associated detector component (cooled charged coupled devices (CCD), intensified charged coupled device (ICCD), microchannel
25 plate detectors, or photon counting photomultiplier (PMT) systems). Alternatively, sensitive CCD chip detectors or avalanche photodiode (APD) detectors can be more directly associated with the APEX device. These systems would
30 somewhat reduce the necessity for complex optics. More advanced systems will involve integrating optoelectronic or electronic detection elements into the APEX chip. Both optical and direct electronic detection of DNA is possible

with these systems. It is contemplated by this invention that the most advanced versions will ultimately involve sandwiching together a microelectronic detector and on board controller component to the basic APEX chip
5 component. Electronic and optical (waveguide) connections would be made directly through the bottom of the APEX component. This strategy solves a number of problems related to fabrication techniques, materials
10 compatibilities, and cost effectiveness for making the APEX component disposable.

In addition to a variety of fluorescent dyes and reporter groups which can be used to label DNA probes, target DNAs, or antibodies; other types of labels or
15 reporter groups can also be used. These include chemiluminescent labels, non-linear optical (frequency doubler) materials, biotin/avidin complexes and various enzymes.

III(e) Combinatorial Biopolymer Synthesis

The devices of this invention are also capable of
20 carrying out combinatorial synthesis of biopolymers such as oligonucleotides and peptides. Such a process allows self-directed synthesis to occur without the need for any outside direction, influence, or mechanical movements. Other processes for combinatorial synthesis require
25 physical masks and complex photolithographic procedures, microrobotic pipetting systems for reagent delivery, or complicated physical movement of components to carry out the actual synthesis at microscopic locations. The combinatorial synthesis disclosed in this invention allows
30 very large numbers of sequences to be synthesized on a device. The basic concept for combinatorial synthesis involves the use free field electrophoretic transport to

deliver, concentrate, and react monomers, coupling reagents, or deblocking reagents at specific addressable micro-locations on the device. The concept capitalizes on the inherent ability of the device to electronically
5 protect other micro-locations from the effects of nearby reagents and reactants. Also important to the concept is the identification of selective steps in these chemical synthesis processes where one or more of the reactants has either a net positive or negative charge, or to create such
10 suitable reagents for these processes.

One method for combinatorial oligonucleotide synthesis is shown in Figure 14. This method begins with a set of selectively addressable micro-locations (140) whose surfaces have been derivatized with blocked primary amine
15 (X-NH-) groups (142). The initial step in the process involves selective deblocking of micro-locations using a charged deblocking reagent (144). In this case, the reagent would carry a positive (+) charge. The process is carried out by applying a negative potential to those
20 micro-locations being de-blocked, and a positive potential to those which are to remain protected (Fig. 14(B)). Application of positive and negative potentials to selective electrodes causes the charged reagents to be moved from a reagent delivery site and concentrated at the
25 desired micro-location to be de-blocked, while excluding reagents from the other micro-locations.

In the second step, chemical coupling of the first base, in this case cytosine, to the deblocked micro-locations is carried out by simply exposing the system to
30 the phosphoramidite reagent (x-C) (146). The (C) nucleotide couples to de-blocked micro-location surfaces, but not to any of the blocked electrode surfaces

(Fig. 14(C) and (D)). At this point normal phosphoramidite chemistry is carried out until the next de-blocking step.

At the second de-blocking step (Fig. 14(D)), those electrode positions which are to be coupled with the next
5 base are made negative, and those which are to remain protected are made positive. The system is now exposed to the next base to be coupled, in this case (x-A) (148), and selective coupling to the de-blocked micro-location is achieved (Fig. 14(E) and (F)). The coupling and de-
10 blocking procedures are repeated, until all the different DNA sequences have been synthesized on each of the addressable micro-location surfaces.

The above example represents one possible approach for the synthesis of nucleic acids. Another approach involves
15 a complete water soluble DNA synthesis. In this case, charged water soluble coupling agents, such as 1-ethyl-3-(3-dimethylaminopropyl) carbodiimide (EDCA), is used to carry out oligonucleotide synthesis with water soluble nucleotide derivatives. This approach would have
20 significant advantages over present organic solvent based methods which require extensive blocking of the base moieties. Water soluble synthesis would be less expensive and eliminate the use of many toxic substances used in the present organic solvent based processes. A third approach,
25 again for water soluble synthesis, involves the use of charged monomers and enzymes.

III(e)(1) Oligonucleotide Synthesis with Terminal Transferase

This approach for combinatorial synthesis of
30 oligonucleotides involves the use of a nucleic acid polymerizing enzymes. This approach utilizes terminal transferase, 3'-monophosphate esters of 5'-

deoxyribonucleotide triphosphates, and a phosphatase. Terminal transferase is used to couple the nucleotides. The 3'-phosphate ester serves as a blocking group to prevent the addition of more than one nucleotide in each
5 coupling step. A 3'-phosphatase is used to remove the 3'-phosphate ester for the next coupling step.

Because all reagents are water soluble and charged, general APEX techniques can be used for all steps in this combinatorial synthesis procedure. In this approach, an
10 APEX matrix is used which has A, T, G, and C nucleotides linked through their 5'-hydroxyl position to the appropriate number of addressed micro-locations on the device. The first nucleotides are linked by standard APEX addressing techniques.

15 The first round of coupling reactions is initiated by biasing positive all those micro-locations which are to be coupled with an A nucleotide in their second position, and biasing negative the two electronic reagent dispensers containing terminal transferase and the 3'-phosphate ester
20 of deoxyadenosine triphosphate. The reagents are free field electrophoresed to the appropriate micro-locations and the A nucleotide is coupled by the terminal transferase to the first nucleotide on the matrix. Because the nucleotide triphosphates are esterified with a phosphate
25 group in their 3' positions, terminal transferase adds only one nucleotide at a time.

After the nucleotide coupling is complete, the micro-locations are biased negative and the waste disposal system is biased positive and the enzyme and spent reagents are
30 removed. The process is repeated for the first round coupling of G, C, and T nucleotides until all the micro-locations have been coupled.

When first complete round of coupling (A, T, G and C) is complete, all the micro-locations are biased positive and a reagent dispenser with a 3'-phosphatase enzyme is biased negative. The 3'-phosphatase is free field
5 electrophoresed to the micro-locations where it hydrolyses the 3'-phosphate ester. The removal of the phosphate ester leaves the 3'-hydroxyl group ready for the next round of coupling reactions. The coupling reactions are carried out until the desired oligonucleotide sequences are complete on
10 the APEX device.

In addition to DNA synthesis, a similar process can be developed for RNA synthesis, peptide synthesis, and other complex polymers.

15 III(f) Electronically Controlled Molecular Biology and Amplification Reactions.

A variety of molecular biological reactions including linear and exponential multiplication or amplification of target DNA and RNA molecules can be carried out with APEX microelectronic devices and chips.

20 Restriction enzyme cleavage reactions and DNA fragment analysis can be carried out under complete electronic control. Nucleic acid multiplication or amplification reactions with APEX devices are distinct from other "DNA Chip" devices which are basically passive micro-matrix
25 supports for conventional amplification procedures (PCR, LCR, etc.). New mechanisms for amplification come directly from the active nature of the APEX devices. The active device provides unique electronic mechanisms to: (1) selectively denature DNA hybrids under isothermal reaction
30 conditions and well below their T_m point (thermal melting temperature); (2) rapidly transport or move DNA back and forth between two or more micro-locations; and (3)

selectively concentrate DNA modifying enzymes, such as, but not limited to, restriction endonucleases, DNA or RNA polymerases, and ligases, at any desired micro-location on the device. Examples of electronically controlled

5 molecular biology and amplification reactions which can be carried out on the APEX devices include: (1) Electronically Directed Restriction Enzyme Cleavage of ds-DNA Sequences; (2) Electronic Multiplication of Target DNA By DNA Polymerases; (3) Electronic Ligation and Multiplication of

10 Target DNA Sequences By DNA and RNA Ligases; and (4) Electronic Multiplication of Target DNA By RNA Polymerases.

III(g) Electronic Restriction Fragment Analysis

In addition to carrying out restriction enzyme cleavage of ds-DNA, APEX devices and electronic techniques

15 can be used to analyze and determine the relative size of DNA fragments. This is possible when DNA fragments with different lengths can be hybridized to a common capture sequence on individual micro-locations. Or when DNA fragments of different lengths can be hybridized to

20 different capture sequences, all of which have the same hybridization or binding energy. In these cases, electronic stringency control can be used to selectively de-hybridize the different DNA fragments according the length of their un-hybridized or overhanging sequence. The electrophoretic

25 force on the fragments with longer overhanging sequences causes them to de-hybridize before the fragments with shorter overhanging sequences. Thus, if the fragments are labelled for detection, and addressed to specific micro-locations, their sizes can be determined by the

30 electrophoretic potential or power level required to de-hybridize them from the micro-locations. It may be

possible to carry out the equivalent of an electronic restriction fragment length polymorphism analysis.

The invention will now be described in greater detail by reference to the following non-limiting examples
5 regarding the making and applications of APEX devices.

The recipes for buffers, solutions, and media in the following examples are described in J. Sambrook, E. F. Fritsch, and T. Maniatis, Molecular Cloning: A Laboratory Manual, 2 Ed., Cold Spring Harbor Laboratory Press, Cold
10 Spring Harbor, New York, 1989.

IV. Examples

EXAMPLE 1: Oligonucleotide Synthesis and Modifications

Synthetic DNA probes were made using conventional phosphoramidite chemistry on Applied Biosystems automated
15 DNA synthesizers. Oligomers were designed to contain either a 5'-amino or a 3'-ribonucleoside terminus. The 5' functionality was incorporated by using the ABI Aminolink 2 reagent and the 3' functionality was introduced by initiating synthesis from an RNA CPG support. The 3'-
20 ribonucleotide terminus can be converted to a terminal dialdehyde by the periodate oxidation method which can react with primary amines to form a Schiff's base.

Reaction conditions were as follows: Dissolve 20-30 O.D. oligomer in water to a final concentration of 1 OD/ μ l.
25 Add 1 vol of 0.1M sodium acetate, pH 5.2 and 1 vol 0.45M sodium periodate (made fresh in water). Stir and incubate reaction for at least 2 hours at ambient temperature, in the dark. Load reaction mix onto a Sephadex G-10 column

(pasteur pipette, 0.6 X 5.5 cm) equilibrated in 0.1M sodium phosphate, pH 7.4. Collect 200 μ l fractions, spot 2 μ l aliquot on thin layer chromatography (TLC) and pool ultra violet (UV) absorbing fractions.

5 The following oligomers contain 3'-ribonucleoside termini (U):

ET-12R	5'-GCT AGC CCC TGC TCA TGA GTC TCU
CP-1	5'-AAA AAA AAA AAA AAA AAA AAU
AT-A1	5'-CTA CGT GGA CCT GGA GAG GAA GGA GAC TGC CTG U
10 AT-A2	5'-GAG TTC AGC AAA TTT GGA GU
AT-A3	5'-CGT AGA ACT CCT CAT CTC CU
AT-A4	5'- GTC TCC TTC CTC TCC AGU
AT-A5	5'- GAT GAG CAG TTC TAC GTG GU
AT-A6	5'- CTG GAG AAG AAG GAG ACU
15 AT-A7	5'- TTC CAC AGA CTT AGA TTT GAC U
AT-A8	5'- TTC CGC AGA TTT AGA AGA TU
AT-A9	5'- TGT TTG CCT GTT CTC AGA CU
AT-A10	5'- CAT CGC TGT GAC AAA ACA TU

Oligomers containing 5' amine groups were generally
20 reacted with fluorophores, such as Texas Red (TR, excitation 590nm, emission 610nm). Sulfonyl chlorides are very reactive towards primary amines forming a stable sulfonamide linkage.

Texas Red-DNA conjugates were made as follows: Texas
25 Red sulfonyl chloride (Molecular Probes) was dissolved in dimethyl formamide (DMF) to a final concentration of 50 mg/ml (80 mM). Oligomer was dissolved in 0.4M sodium bicarbonate, pH 9.0-9.1, to a final concentration of 1 O.D./ μ l (5.4 mM for a 21-mer). In a micro test tube, 10 μ l
30 oligomer and 20 μ l Texas Red was combined. Let reaction proceed in the dark for 1 hour. Quench reaction with ammonia or hydroxylamine, lyophilize sample and purify by PAGE (Sambrook et al., 1989, supra).

The following oligomers contained a 5'-amino termini:

	ET-21A	5'-Amino-TGC GAG CTG CAG TCA GAC AT
	ET-10AL	5'-Amino-GAG AGA CTC ATG AGC AGG
	ET-11AL	5'-Amino-CCT GCT CAT GAG TCT CTC
5	T-2	5'-Amino-TTT TTT TTT TTT TTT TTT T
	RC-A1	5'-Amino-CAG GCA GTC TCC TTC CTC TCC AGG TCC ACG TAG
	RC-A2	5'-Amino-CTC CAA ATT TGC TGA ACT C
	RC-A3	5'-Amino-GGA GAT GAG GAG TTC TAC G
10	RC-A4	5'-Amino-CTG GAG AGG AAG GAG AC
	RC-A5	5'-Amino-CCA CGT AGA ACT GCT CAT C
	RC-A6	5'-Amino-GTC TCC TTC TTC TCC AG
	RC-A7	5'-Amino-GTC AAA TCT AAG TCT GTG GAA
	RC-A8	5'-Amino-ATC TTC TAA ATC TGC GGA A
15	RC-A9	5'-Amino-GTC TGA GAA CAG GCA AAC A
	RC-A10	5'-Amino-ATG TTT TGT CAC AGC GAT G

EXAMPLE 2: Electronically Addressable Micro-locations on a Microfabricated Test Device - Polylysine Method

- Micro-locations were fabricated from microcapillary tubes (0.2 mm x 5 mm). The microcapillaries were filled with 18-26% polyacrylamide containing 0.1 - 1.0% polylysine and allowed to polymerize. The excess capillary was scored and removed to prevent air bubbles from being trapped within the tubes and to standardize the tube length.
20. Capillaries were mounted in a manner such that they shared a common upper buffer reservoir and had individual lower buffer reservoirs. Each lower buffer reservoir contained a platinum wire electrode.

- The top surface of the microcapillary in the upper reservoir was considered to be the addressable micro-location. The upper and lower reservoirs were filled with 0.1 M sodium phosphate, pH 7.4 and pre-run for 10 minutes

at 0.05 mA constant using a BioRad 500/1000 power supply. About 2 μ l (0.1 O.D.) of periodate oxidized ET-12R capture sequence was pipetted into the upper reservoir with the power on and electrophoresed for 2-5 minutes at
5 constant current. The ET-12R capture sequence becomes concentrated and immediately covalently bound to the primary amines on the micro-location surface. The polarity was then reversed so that the test capillary was now biased negative and electrophoresed an additional 2-5 minutes.
10 Any remaining un-bound DNA sequences were repulsed while the covalently attached DNA remained at the micro-location.

The upper buffer reservoir was aspirated and rinsed with buffer. The apparatus was disassembled and a fresh reference test device was mounted. The reservoir was
15 refilled and fluorescently labeled complement DNA sequence added, i.e., ET-10AL-TR. The oligomer was electrophoretically concentrated at the positively biased test micro-location for 2-5 minutes at 0.05 mA constant current. The polarity was reversed and unbound complement
20 removed. The test devices were removed and examine by epifluorescence microscopy. A negative control for non-specific binding was performed as described above substituting a non-complementary DNA sequence ET-21A-TR for ET-10AL-TR.

25 The cross-sections of the capillary micro-locations surfaces were examined under a Jena epifluorescent microscope fitted with a Hamamatsu ICCD camera imaging system. The fluorescent analysis results indicated that complement ET-10AL-TR sequence hybridized to the binding
30 entity/capture sequence and remained hybridized even when the potential was biased negative. The ET-21A-TR non-complement sequence was not retained at the test device surface when the potential was reversed.

EXAMPLE 3: Electronically Addressable Micro-locations on a Microfabricated Test Device - Succinimidyl Acrylate Method

This example describes an alternative attachment chemistry which covalently binds the 5'-terminus of the oligonucleotides. Capillaries were fabricated as described above except that 1% succinimidyl acrylate (Molecular Probes) was substitute for polylysine. The capillaries were made up fresh because the succinimidyl ester used to react with primary amines is relatively labile, especially above pH 8.0. The capillaries were mounted as described above and the reservoirs were filled with 0.1 M sodium phosphate, pH 7.4. The capillaries were pre-run for 10 minutes at 0.05 mA. About 2 μ l ET-10AL (0.1 O.D.), which contains a 5'-amino terminus, was pipetted into the upper reservoir with the power on and electrophoretic transport carried out for 2-5 minutes. The polarity was reversed so that the test devices were biased negative and electrophoresed an additional 2-5 minutes. The un-bound DNA was repulsed, while the covalently attached DNA remained at the micro-location.

The upper buffer reservoir was aspirated and rinsed with buffer. The reference test device was un-mounted and a new reference device mounted. The reservoir was re-filled and the fluorescent labeled complement oligomer ET-11AL-TR was added and electrophoresed as described above. A negative control for non-specific binding was performed as described above substituting a non-complement DNA sequence ET-21A-TR for ET-11AL-TR.

Fluorescent analysis of each of the test devices showed that the complement ET-11AL-TR hybridized to the capture sequence (ET-10AL), and remained hybridized even when the potential was changed to negative. The non-

complementary sequence, ET-21A-TR, was not retained at the micro-location when the potential was reversed.

EXAMPLE 4: Electronically Controlled Fluorescent DNA/Dye Detection Process

5 Certain dyes such as ethidium bromide (EB) become highly fluorescent when bound (intercalated) into double-stranded DNA. While the fluorescence and binding affinity is greater when bound into double-stranded DNA; the dye also has some affinity for single-stranded DNA and produces
10 low level fluorescence when bound. The following example shows how an electronically controlled DNA/Dye detection process can be developed.

Microcapillary test devices were prepared and hybridized as described in Example 2 and 3. Ethidium
15 bromide (EB) was added to the buffer solution (~ 0.05 mM EB final concentration) and the test devices were biased negative to concentrate EB (positively charged) at both the hybridized and un-hybridized micro-locations. The test devices were observed by epifluorescence microscopy at 550
20 nm excitation and 600 nm emission. Both the hybridized and un-hybridized micro-locations showed intense red fluorescence from the concentrated EB.

The test devices were re-mounted biased positive constant current at 0.05 mA for 0.03 Volt-Hours, to
25 selectively remove the EB. Fluorescence at the un-hybridized micro-locations diminished while the hybridized micro-locations retained a very high level of EB fluorescence. The results are given below:

	<u>Capture</u>	-	<u>Target</u>	<u>Normalized Signal</u>
30	ET-10AL		ET-11AL (Pos.)	>200
	ET-10AL		ET-21A (Neg.)	1

Fluorescent signal was measured using an ICCD imaging camera system and represent peak fluorescent intensities. The signal to noise ratio would be more than 1000 fold if the entire fluorescent signal area was integrated. This demonstrates a method for increasing signal to noise ratios and the dynamic range of the DNA assays using intercalating dyes.

EXAMPLE 5: Electronically Addressable Locations on Metal Substrates

10 Aluminum (Al) and gold (Au) wire (0.25 mm, Aldrich) were reacted with 10% 3-aminopropyltriethoxysilane (APS) in toluene. The APS reagent reacts readily with the oxide and/or hydroxyl groups on the metal surface to form
15 covalent bonds between the oxide and/or hydroxyl groups and the primary amine groups. No pretreatment of the aluminum was necessary. The gold wire was subjected to electrolysis in 5 x SSC solution to form an oxide layer. Alternatively the metal wire can be oxidized by a perchloric acid bath.

The APS reaction was performed as follows: Wires were
20 cut to 3 inches and placed in a glass dish. Toluene was added to completely cover the wires and the temperature was brought to 50-60 °C on a heat plate. APS was added to a final concentration of 10%. Mix solution and continue the reaction for 30 minutes. Rinse 3 times with copious
25 volumes of toluene, then rinse 3 times with copious volumes of alcohol and dry in 50°C oven.

The APS treated wire can then be reacted with an aldehyde to form a Schiff's base. Binding entity ET-12R was periodate oxidized as described elsewhere in the
30 specification. The electrodes were placed in a reservoir of degassed water. Power was applied at .05 mA constant for about 30 seconds. Activated ET-12R was immediately

added. Power was applied, the liquid was aspirated and fresh water was added and then aspirated again. The test (biased positive) and reference electrodes were placed in Hybridization Buffer (HB, 5XSSC, 0.1% SDS) containing
5 fluorescent labeled complement DNA, ET-10-TR. After 2 minutes the electrodes were washed three times for one minute each in Wash Buffer (1 x SSC, 0.1% SDS) and observed by fluorescence (ex. 590 nm, em. 610 nm).

Results demonstrate that ET-12R was specifically
10 coupled to the treated metal surfaces. The test electrode was fluorescent while the reference electrode was not. Non-specific adsorption of the DNA to the metal was prevented by the presence of SDS in the hybridization buffer. Attachment to gold substrates by electrolysis and
15 subsequent APS treatment was effective. Signal obtained was significantly stronger than observed with non-oxidized gold. More importantly, this example showed that the metal surfaces could be chemically functionalized and derivatized with a binding entity and not become insulated from the
20 solution. The APS method represents one of many available chemistries to form DNA-metal conjugates.

EXAMPLE 6: Electronically Controlled Fluorescent Dye Detection Process - Metal Wire

DNA-aluminum electrode substrates were prepared and
25 hybridized as described in Example 5. A hybridized and an un-hybridized DNA-Al electrode were processed with an un-derivatized Al wire as the reference. Ethidium bromide (EB) was added to the solution and the test DNA electrodes were biased negative to attract the dye. The solution was
30 aspirated and fresh buffer was added. The metal surfaces were examined under the microscope.

Remount the device and apply a positive potential for a defined volt-hour. The buffer was aspirated, the electrodes were observed by epifluorescence. This was repeated until there was a significant difference in
5 fluorescence between the hybridized and un-hybridized metal surfaces.

<u>Capture</u>	<u>Target</u>	<u>Normalized Signal</u>
ET-12R	ET-10AL (Pos.)	>140
ET-12R	None (Neg.)	1

10 Fluorescence at the unhybridized metal surfaces diminished while the hybridized metal surfaces retained fluorescence. Fluorescent signal was measured using an ICCD camera imaging system and represent peak fluorescent intensities. The signal to noise ratio would be >>1000
15 fold if the entire fluorescent signal area was integrated. This example demonstrates a method for increasing signal to noise ratios and thus the dynamic range of the assay. Similar results were obtained using capillary gel configuration, suggesting that electrochemical effects do
20 not significantly affect the performance of the assay.

EXAMPLE 7: Active Programmable Electronic Matrix (APEX) - Micro-Machine Fabrication

A radial array of 6 addressable 250 μm capillary locations was micro-machined from plastic substrate
25 material. The device has a common upper reservoir and separate lower reservoirs such that each micro-location is individually addressable. A unique oligomer sequence binding entity is localized and attached to a specific micro-locations made from highly crosslinked polyacrylamide
30 by the methods described previously. The test micro-location has a positive potential while the other micro-

locations have negative potentials to prevent non-specific interactions.

The array is washed and then hybridized with a complementary fluorescently labeled DNA probe. The array is washed to remove excess probe and then observed under an epifluorescent microscope. Only the specifically addressed micro-location are fluorescent. The process is repeated with another binding entity at another location and verified by hybridization with a probe labeled with another fluorescent moiety.

DNA sequences are specifically located to predetermined positions with negligible crosstalk with the other locations. This enables the fabrication of micromatrices with several to hundreds of unique sequences at predetermined locales.

To select appropriate plastic substrates of low fluorescent background, different plastic substrates were tested as to their fluorescent characteristics at 600 nm. The plastics were tested by an epifluorescent microscope imaging system and by a fluorometer. The following table provides the list of substrates and fluorescent readings obtained from an LS50B fluorometer:

Plastic Substrate	Intensity at 610 nm, 5 sec int.
ABS black	0.140
white	6.811
Polystyrene	7.955
Acrylic clear	0.169
white	51.77
tinted	0.151
black	0.035

	transwhite	51.22
	UHMW black	0.743
	white	
5	Delrin black	1.834
	white	61.39
	TFE	96.05
	Polypropylene white	22.18
	natural	25.82
	Polycarbonate clear	11.32
10	tinted	3.103
	white	45.31
	black	0.156
	PVC gray	2.667

The experiments show that black acrylic, ABS, and polycarbonate have the lowest fluorescence background levels.

EXAMPLE 8: Active, Programmable Electronic Matrix (APEX) - Microlithographic Fabrication

An 8 X 8 matrix (64 sites) of 50 μm square micro-locations on a silicon wafer (see Figure 3) was designed, fabricated and packaged with a switch box (see Device Fabrication Section for details). Several materials and process improvements, as described below, were made to increase the selectivity and effectiveness of the APEX DNA chip device.

8a) Selection of Topcoat

The APS (3-aminopropyltriethoxysilane) process involves reacting the entire surface of the chip. Selectivity of this initial functionalization process is

dependent on the relative reactivities of the various materials on the chip surface. In order to reduce functionalization and subsequent DNA attachment to the areas surrounding the micro-locations, a material that is less reactive to APS than SiO₂ or metal oxide is needed. Photoresists and silicon nitride were tested. The different topcoats were applied to silicon dioxide chips. The chips were examined by epifluorescence and then treated with APS followed by covalent attachment of periodate oxidized poly-A RNA sequences (Sigma, M 100,000). The chips were hybridized with 200 nM solution of Texas Red labeled 20-mer (T2-TR) in hybridization buffer, for 5 minutes at 37°C. The chips were washed 3 times in washin buffer and once in 1 x SSC. The chips were examined by fluorescence at 590 nm excitation and 610 nm emission.

Silicon nitride was chosen because it had much less reactivity to APS relative to silicon dioxide and was not inherently fluorescent like the photoresist materials tested. Other methods such as UV burnout of the background areas are also possible.

8b) APEX Physical Characterization

A finished matrix chip was visually examined using a Probe Test Station (Micromanipulator Model 6000) fitted with a B & L microscope and a CCD camera. The chip was tested for continuity between the test pads and the outer contact pads. This was done by contacting the pads with the manipulator probe tips which were connected to a multimeter. Continuity ensures that the pads have been etched down to the metal surface. The pads were then checked for stability in electrolytic environments. The metal wires were rated to handle up to 1 mA under normal dry conditions.

A drop (1-5 μ l) of buffered solution (1 x SSC) was pipetted onto the 8X8 matrix. Surface tension keeps the liquid in place leaving the outer contact pad area dry. A probe tip was contacted to a contact pad and another probe tip was contacted with the liquid. The current was incrementally increased up to 50 nA at maximum voltage of 50 V using a HP 6625A power supply and HP3458A digital multimeter.

The initial fabrication consisted of the silicon substrate, a silica dioxide insulating layer, aluminum deposition and patterning, and a silicon nitride topcoat.

The second fabrication process included a silicon dioxide insulating layer between the aluminum metal and silicon nitride layers. Silicon dioxide and Al have more compatible physical properties and form a better chemical interface to provide a more stable and robust chip than that made by the initial fabrication process.

8c) DNA Attachment

An 8 x 8 matrix chip was functionalized with APS reagent as described in Example 5. The chip was then treated with periodate oxidized poly-A RNA (Sigma, average M 100,000). The chip was washed in washing buffer (WB) to remove excess and unbound RNA. This process coated the entire chip with the capture sequence, however there is a much higher density at the exposed metal surfaces than at the nitride covered areas. The chip was hybridized with a 200 nM solution of T2-TR in hybridization buffer (HB) for 5 minutes at 37°C. Then washed 3 times in WB and once in 1XSSC for one minute each at ambient temperature. The chip was examined by fluorescence at 590 nm excitation and 610 nm emission.

The opened metal areas were brightly fluorescent and had the shape of the 50 um square pads (micro-locations). Low fluorescent intensities and/or irregular borders suggest that some pads were not completely opened.

5 Additional plasma etch times would be recommended in these cases.

8d) Electronically Controlled Hybridization

Active hybridization was performed by using a chip from Example 8c and biasing one specific micro-location
10 positive. This was done by using the switch box which would also automatically bias the remaining micro-locations negative or by using an electrode in the external solution. Three microliters of buffer was deposited on the matrix pads (micro-locations) only. A current, ~1-5 nA, was
15 applied for several seconds and 0.1 pmole of T2-TR was added to the solution. The liquid was removed and the chip was dried and examined for Texas Red fluorescence at excitation 590 nm and emission em.610 nm. Only the specific micro-location biased positive was fluorescent.
20 This experiment was repeated many times, using other specific micro-locations on the APEX chip. Additionally, the fluorescence DNA at one micro-location was electronically de-hybridized and translocated to another micro-location by biasing the initial location negative and
25 the destination micro-location positive.

8e) Electronically Controlled Addressing and Device Fabrication

The 8 x 8 APEX matrix was functionalized with APS as described previously. The oligonucleotide binding entity
30 CP-1 was activated by periodate oxidation method. Four micro-locations were biased positive in the matrix and the

remainder were biased negative. Two microliters of buffer was deposited on the matrix and a current was applied. The binding entity, CP-1, was added and electronically concentrate at the designated locations. The liquid was removed, the chip was rinsed briefly with buffer and two microliters of buffer was deposited on the chip. Again, current was applied for several seconds and 0.1 pmole of T2-TR was added. The liquid was removed after a short time and the entire chip was washed in WB, 3 times. The chip was dried and examined for fluorescence.

Results indicate that the four positively biased micro-locations were all fluorescent. This example demonstrates the selective addressing of micro-locations with a specific binding entity, the localization and covalent coupling of the attachment sequences to the micro-locations, and the specific hybridization of complementary target sequences to the derivatized micro-locations.

8f) Genetic Typing APEX Chip

DNA binding entities with 3'-ribonucleoside termini are synthesized which are specific for the polymorphisms of HLA gene dQa. The binding entities are activated by periodate oxidation as described previously. The reverse complements are synthesized with 5'-amino termini and are conjugated with fluorophores, such as Texas Red, Rhodamine or Bodipy dyes, as described previously. The micro-locations are functionalized with primary amines by treatment with APS, as described previously.

Several microliters of solution are placed over the 8 x 8 matrix. A specific micro-location is addressed by biasing that micro-location positive, the periodate oxidized DNA oligomer is added, at ~0.1 pmole, and is translocated and covalently coupled to that location. The

polarity is reversed and the un-bound binding entity molecules are removed. This is repeated for another binding entity at another addressed micro-location until all the unique attachment binding entities are bound to the
5 chip.

The chip is then hybridized to individual fluorescently labeled complement sequences to determine the specificity of the coupling reaction as well as to visualize all addressed micro-locations at once.

10 On the same chip which is electronically denatured to remove complementary oligomers (10 minutes at 90°C in 0.05% SDS), the addressed micro-locations are hybridized with unlabeled target DNA or genomic DNA. Detection is via the fluorescent dye detection assay as described previously in
15 the specification.

Results will demonstrate that micro-locations are specifically addressed with unique binding entities. Non-specific binding to negatively biased micro-locations will be negligible. The device and associated binding entity
20 chemistry is stable under denaturation conditions, thus making the addressed and fabricated device reusable. Electronic methods for denaturing the hybrids would be to increase the current and/or increase the time it is applied.

25. EXAMPLE 9: Electronic Stringency Control

9A) Single Point Mutations with 15-mer Ras-12 Probes

The ability of the device to affect a high level of electronic stringency control was demonstrated with a Ras-12 oncogene model system using 15-mer probes. A single
30 base pair mis-match in a DNA duplex causes only a slight instability in the hybrid pair relative to the matched duplex. This slight instability causes the mis-matched

duplex to denature at a slightly lower T_m than the matched duplex. When the pairs (match and mis-match) are both hybridized at optimal stringency for the matched pair, the mis-matched pair will hybridize with less efficiency. The hybridization signal from the mis-match will be somewhat less than the signal from the matched pair. With conventional hybridization procedures, single point mutation analysis can be carried out with probes in the 8-mer to 21-mer range. Probes in the 10-mer to 20-mer range are used most often. When mutation specific probes become shorter than 8-mers or longer than 20-mers, it becomes extremely difficult to discriminate the match from the mis-match in any reliable manner. This is because there is little difference in the hybridization signals between the match and the mis-matched pairs. The traditional methods of hybridization stringency control used in point mutation analysis rely on temperature and salt concentrations. We have found that stringency control can also be affected by the electrophoretic potential.

In the Ras-12 example, 15-mer point mutation specific probes were electronically hybridized to 30-mer target sequences attached to the micro-locations on test devices. The polarity at the micro-locations was biased negative, and the hybrids were subjected to constant current for a given time, providing a defined power level which denatures the mis-match without affecting the perfect match.

The following sequences were synthesized and tested on a set of three test structures, each with a 250 μm surface micro-location. The underlined/bold faced base indicates the mis-match position.

The attachment sequences were:

Ras-G 5'-GGT GGT GGG CGC **CGG** CGG TGT GGG CAA GAU-3'-
micro-location

Ras-T 5'-GGT GGT GGG CGC CGT CGG TGT GGG CAA GAU-3' -
micro-location

The reporter probe sequences (labelled with Texas Red) were:

- 5 Ras-1 3'-CC-GCG-GCC-GCC-ACA-C-5'-(TR)
Ras-2 3'-CC-GCG-GCA-GCC-ACA-C-5'-(TR)
Ras-3 3'-CC-GTG-GCA-GCC-ACA-C-5'-(TR)

Test devices were fabricated from microcapillary tubes as described previously in the specification. Attachment
10 sequences Ras-G and Ras-T were periodate oxidized and covalently bound to the addressed micro-locations.

Ras-G micro-locations were then hybridized with Ras-1, Ras-2 or Ras-3. Ras-1 is the perfect match to Ras-G. Ras-2 is a one base pair mismatch (G-A). Ras-3 is a two base
15 pair mismatch (G-A and G-T). The G-A mis-match produces the least destabilization to the DNA duplex, and is therefore the most difficult to distinguish from the perfect match.

Conventional hybridization was first carried out and
20 the micro-locations were examined fluorescently to measure to what extent complementary sequences were hybridized. The test devices (microcapillaries) were re-mounted and electronic hybridization was then carried out. The test devices were all subjected to the same electronic
25 stringency by biasing them at a negative potential (at constant current) until the mis-matched hybrids were completely removed without significantly affecting the perfectly matched hybrid. The procedure and results are shown below:

30 Conventional Hybridization Procedure:

- Hybridize in 5X SSC for 15 minutes at 40° C
- Wash 3 times in 1X SSC for 5 minutes each 20° C

- Carry out fluorescent analysis
- Observed signal ratio of perfect match (Ras-G/Ras-1) to 1 bp mis-match (Ras-G/Ras-2): about 10 to 1

Electronic Stringency Control (ESC) Procedure:

- 5 - Hybridize in 5X SSC for 5 minutes at 20° C
- "No washing procedure"
- Apply an electronic stringency of 0.15 milliamps (MA) at 150 volts (V) for 4 minutes (20° C)
- Carry out fluorescent analysis
- 10 - Observed signal ratio of perfect match (Ras-G/Ras-1) to 1 bp mis-match (Ras-G/Ras-2): > 100 to 1

The complete results for all the experiments are shown graphically in Figure (15). These results show that it is not only possible to use electrophoretic potential for stringency control in DNA hybridization reactions; but also show that ESC provides both higher hybridization efficiencies and higher discrimination ratios than conventional hybridization procedures. In addition, ESC can be applied to each individual micro-location, providing independent stringency control in the same bulk solution.

(9B) Single Point Mutation Analysis using 7-mers and 22-mer Probes

Both 7-mer and 22-mer probes, which are well outside the normal size range commonly used in point mutation analysis, were prepared to further demonstrate the advantages of electronic hybridization and ESC. The point mutation specific oligomer probes listed below can be paired such that resulting hybrids have 0, 1, or 2 base mis-matches. Complementary oligomer sequences were coupled to micro-locations and hybridized as described above. The

polarity at the micro-locations was reversed (biased negative) and the hybrids subjected to constant current for a given time, providing a defined power level to denature the mis-matches without removing the perfect match.

5 The Ras-G or Ras-GA oligomers (shown below) were attached to micro-locations and used as target sequences. The series of 22-mer and 7-mer Ras specific oligomer shown below were labeled with Texas Red fluorophore as described elsewhere in the specification. The "underlined and bold
10 faced" bases indicates the mis-matched and/or potential mis-matched positions:

Ras-G	5'-GGT GGT GGG <u>CGC</u> <u>CGG</u> <u>CGG</u> TGT GGG CAA GAU
Ras-GA	5'-Amino-GGT GGT GGG <u>CGC</u> <u>CGG</u> <u>CGG</u> TGT GGG CAA GA
15 Ras-22C-TR	(TR)-5'-TGC CCA CAC <u>CGC</u> CGG CGC CCA C
Ras-22A-TR	(TR)-5'-TGC CCA CAC <u>CGA</u> CGG CGC CCA C
Ras-TA	(TR)-5'-TGC CCA CAC <u>CGA</u> CGG <u>TGC</u> CCA C
Ras-7C	(TR)-5'-ACA <u>CCG</u> C
Ras-7A	(TR)-5'-ACA <u>ACG</u> C

20 Test devices were fabricated from microcapillary tubes as described previously in the specification. The oligomer target sequences Ras-G or Ras-GA were covalently attached to the micro-locations. One micro-location was then hybridized with the Texas Red labeled perfect 22-mer
25 complement Ras-22C-TR. A second micro-location was hybridized with Ras-22A-TR, a 22-mer one base pair mismatch (G-A); or the Ras-22-TA the 22-mer two base pair mismatch (G-A and G-T).

The test devices, as described above in the
30 specification, were run concurrently in the dual channel mode where both micro-locations experience the same current

or power levels simultaneously. The test devices were first hybridized by conventional procedures and the micro-locations examined fluorescently to determine the amount of complementary sequences which had hybridized. The test
5 devices were then used to carry out electronic hybridization to controlled time at constant current until the mis-matched hybrids were removed without significantly affecting the perfectly matched hybrids. A Bio-Rad 1000/500 power supply was typically set to 0.02 to 0.1 mA
10 and the experiments were run at constant current for 0.02 to 0.04 volt-hours. The device was disassembled and the test devices were observed by epifluorescence on a Jena microscope fitted with a silicon intensified CAD camera (Hamamatsu). The images were processed by a Hamamatsu
15 Argus 10 image processor and recorded by a Sony Video Printer. The capillaries were re-run when additional electronic stringency was required.

Single base pair mis-match discrimination was performed on the 7-mers as described above. However, due
20 to their lower T_m , the device was run in a cold box at 4-6°C rather than at room temperature.

Results indicated that electronic hybridization and stringency control could discriminate single base pair mismatches using both 7-mers and 22 mers. The match:mismatch
25 ratios were 100:1 or greater. This signal:noise ratio was generally better than what was reported by any hybridization methods which use temperature and ionic strength to control stringency conditions.

Electronic stringency control was able to distinguish
30 a one base G-A mismatch from the perfect match eventhough the G-A mismatch is the most stable mis-match because the G imino proton can participate in hydrogen bonding with A which can stabilize the duplex.

Power dissipation calculations and measurements showed negligible changes in temperature, demonstrating that the stringency was not caused by temperature changes at the micro-locations. Micro-locations which were passively
5 hybridized as described above (not subjected to a electronic hybridization) showed no discrimination between match and mis-match demonstrating that diffusion was not causing the discrimination.

These examples also demonstrate that each micro-
10 location can have individual stringency control, and thus overcome a major obstacle to large scale multiplex hybridization techniques which are limited to a single common stringency level. It is also possible to correlated electronic stringency power levels with thermal melting
15 (T_m) data to generate predictive electronic melting (E_m) curves and equations.

(9C) Electronic Hybridization in High Genomic Background

Actual target DNA sequences usually make up only a
20 very small proportion of the total DNA in a genomic DNA sample. By concentrating total DNA at a very small location on an APEX device, this invention increase the efficiency of target hybridizations in the presence of an excess of heterologous DNA.

25 In this example, attachment sequences bearing 5'-amine groups were attached to test devices containing 22% PAGE, 1% succinimidyl acrylate. The capillaries were derivatized with either ET-23AL or ET-11AL capture sequences. The target probe ET-12R was labelled with Texas Red. ET-12R-TR
30 would hybridize to ET-23AL but not to ET-11AL capture sequences, the test and the control, respectively.

The heterologous genomic DNA, calf thymus DNA (CT DNA, Sigma), was dissolved to a final concentration of 1 mg/ml water, sonicated and heated to denature the DNA. Samples were prepared in 0.5X TBE containing 10^{10} copies of ET-12R-TR target with 0, 0.1 μg , or 1.0 μg of denatured CT DNA in a final volume of 100 μl . This represented a 0, 1,000, or 10,000 fold excess of CT DNA relative to target DNA.

Test devices were pre-run 5 minutes at 0.03 mA in 0.5X TBE using a Bio-Rad 1000/500 power supply. The device was set to run in dual channel mode so that a test and control capillary could be run at the same time under exactly the same conditions. The sample was applied (100 μl) and the capillaries were biased with a positive potential to attract DNA for 5 minutes at 0.03 mA. The polarity was reversed and the same power was applied to remove all un-hybridized ET-12R-TR target from the test device surface. The buffer was aspirated and the test devices were observed by epifluorescence on a Jena microscope fitted with a silicon intensified CAD camera (Hamamatsu). The images were processed by a Hamamatsu Argus 10 image processor and recorded by a Sony Video Printer.

There was no difference between the absolute hybridization signal and the signal/noise ratios in the presence and absence of 0.1 μg CT DNA per 100 μl . The signal intensity was equivalent and the signal was uniformly distributed across the active area.

At the level of 1 μg CT DNA per 100 μl , the signal was predominantly distributed around the perimeter of the capillary, suggesting that the capture sequences were blocked or saturated. This artifact was easily surmounted by oscillating the polarity during the hybridization step. This would pulse the total DNA towards and away from the

active area, allowing the target to hybridize more efficiently and uniformly.

(9D) Passive Hybridization vs. Electronically Controlled Hybridization

5 Electronically controlled hybridization is more efficient and faster than passive hybridization because of the concentration effect in the electronically controlled hybridization.

10 Microcapillary test devices were made up with ET-23AL and ET-11AL attachment sequences, as test and control devices respectively. A hybridization solution containing 1×10^{10} copies of ET-12R-TR with 1 μ g CT DNA in a total volume of 100 μ l was made up.

Passive hybridization:

15 A set of test and control devices were placed in a small test tube with 100 μ l of hybridization solution at 50°C, and hybridized for 15 minutes. The samples were then washed 3 times in 1x SSC, 0.1% SDS, 5 minutes for each wash at 45°C.

20 Electronically controlled hybridization:

Test devices were mounted and pre-run for 5 minutes at 0.06 mA. The buffer was then aspirated and 100 μ l of hybridization solution was added. The test devices were biased positive for 3 minutes at 0.06 mA. the polarity was 25 then reversed for 30 seconds, and reverse again so the test devices were once again positive for additional 3 minutes. The test devices were biased negative for 3 minutes to electronically wash.

The efficiency and extent of hybridization was 30 significantly better with the active format than with the passive format. Absolute signal in the active (electronic) format was more than 100 fold higher than the signal in the

passive format. The signal/noise ratio in the active format was increased 10 fold over the signal in the passive format. The active hybridization assay was completed in under 10 minutes with minimal manipulations. The passive
5 format required ~ 30 minutes with several manipulations of tubes and buffers.

Traditional hybridization methods use 2.5 nM probe at 3 times C_{0t} , for 15 minutes, for 90% completion of the reaction. At our experimental concentration of 0.17 nM
10 probe, the passive hybridization reaction kinetics would normally require ~ 4 hrs.

Active hybridization enables the use of lower probe concentrations which result in lower background. Traditional methods depend on diffusion and thus must use
15 higher probe concentrations to drive the reaction kinetics. The active method is able to concentrate the sample into a very small volume which results in a very high local probe concentration and subsequently very fast hybridization reaction kinetics.

20 EXAMPLE 10: Hybridization with Fluorescent DNA Nano-Structure

Normally, the overall sensitivity for non-amplification type hybridization assays is limited by background from the non-specific binding. This is often a
25 major problem when multiple reporter groups, or secondary complexes with multiple reporter groups, are used to label DNA probes. Therefore, the assay detection limit is often reached well before the actual or intrinsic detection limit of the reporter label(s) is reached.

30 Using electronic controlled hybridization methods, we have found that highly fluorescent sub-micron or nano-scale beads may be used with attached DNA probes for ultra-

sensitive assays. We have been able to control the movement of DNA probe-fluorescent nanostructures using free field electrophoresis. Since electronic stringency control provides high level discrimination of hybridized from un-
5 hybridized structures, DNA probe-fluorescent nanostructures can significantly increase hybridization sensitivity. Electronic stringency control allows us to utilize these highly fluorescent nanostructures or other multiple labeling scenarios for low copy number (50 to 1000 targets)
10 detection, without amplification being necessary. To date, this has not been possible with conventional hybridization methods and procedures.

Fluorescent nanoparticles, Fluorospheres, were obtained from Molecular Probes, Inc.. The particles are
15 composed of carboxymethyl latex spheres loaded with fluorescent dyes, such as Texas Red or fluorescein. The latex spheres can be obtained with different functional groups on their surface, such as amine or aldehydes. The particles are available in sizes from 0.01 to 5 μm in
20 diameter.

1) Characterization of the Fluorescent Nanoparticles

The nanoparticles, unmodified, amine modified, or aldehyde modified, have a net positive charge. In an electric field these particles migrate towards the
25 negatively biased micro-locations.

2) DNA Attachment Chemistry to the Fluorospheres

The amine modified particles can be coupled to nucleic acids bearing terminal aldehyde groups. The latter can be generated by DNA probes synthesized with a 3'- terminal
30 riboside which is subsequently oxidized by the periodate method as described previously in the specification.

The particles are stored as a 2% suspension in distilled water. An aliquot of 25 to 50 μ l of the 0.02 - 1.0 μ m amine modified red fluorescent Fluospheres was pelleted and re-suspended in 0.1M sodium phosphate, pH 7.4.

5 An excess of periodate oxidized poly ribo-A was added to the suspension. The reaction was allowed to incubate for 90 minutes at room temperature. The particles were washed and pelleted several times in 1x SSC, 0.1% SDS (0.15 mM sodium chloride, 0.015 mM sodium citrate, 0.1% (w/v) sodium

10 docecyl sulfate, pH 7.0) to remove unbound and non-specifically bound poly ribo-A.

The DNA-fluospheres in buffered solution were placed in a direct current electric field. It was observed that the DNA-Fluospheres migrated towards the positive

15 electrode, indicating that their net charge was now negative. This is a simple and convenient method to determine if the DNA coupling reaction was successful. Traditional hybridization methods would require using a radiolabeled reporter probe because the intense

20 fluorescence from the particles would obscure any hybridization signal.

3) DNA Attachment to Test Devices

The test devices were polymerized with highly cross-linked polyacrylamide, containing 1% succinimidyl acrylate,

25 which can be subsequently reacted with 5'-amine terminated DNA probes. The attachment of the capture sequence, oligo-T, was verified by hybridization with fluorescently labeled complement probe, CP-1-TR. The test device surfaces were highly fluorescent which indicates that the surface was

30 derivatized with capture sequences.

4) Electronic Hybridization and Detection of DNA-Fluorospheres

The hybridization reactions were performed in a structure which holds 2 microcapillary test devices sharing a common upper reservoir and independent lower reservoirs. The reactive surfaces are exposed to the common upper reservoir.

The test devices were mounted in the structure and pre-run in 0.5x TBE at 0.05 mA, for 15 minutes. One test device had the T2 complementary attachment sequences, and the other had ET-10AL non-complementary attachment sequence. One microliter of DNA-fluospheres at was added to the upper reservoir. The test devices were biased positive at .02 mA, for 5 minutes, to attract the DNA-Fluorospheres (fluorescent nanoparticles). The test devices were inspected to determine that the particles were present on the surfaces. The polarity was reversed such that the test devices were now biased negative and the un-hybridized DNA-Fluorospheres should be repelled.

There was no discrimination between the test and the control devices. The particles could not be removed after repeated attempts regardless of the amount of power applied.

5) Passive Hybridization and Detection of DNA-Fluospheres

Without being bound by any theory or hypothesis, we believe that electronic hybridization of the particles physically embeds or traps the particles in the surface gel matrix of the test devices. Thus, DNA-Fluospheres which are passively hybridize to the attachment sequences on the gel surfaces, should be more easily removed by electronic de-hybridization.

New test devices was mounted as described above. A 0.05% suspension of DNA-Fluorospheres were pipetted into the upper reservoir and passively hybridized for 5 minutes. The buffer was aspirated and fresh 1x TBE buffer was added. The test devices were now biased negative to repel the particles. The test devices was operated for 5 minutes at 0.02 mA, and then inspected by fluorescence.

There was now significant discrimination between the test and control devices after performing ECS for a total of 10 minutes at room temperature. The signal was not uniformly distributed across the test surface, but concentrated in signal pockets. This may suggest that the availability of the surface attachment sequences is limited. Improvements can be made using longer spacer arms with either hydrophobic, hydrophilic, or mixed character. Such spacers for example can be built using diamino-hexane, succinic anhydride, and a variety of other spacer groups well known in art.

EXAMPLE 11: Electronically Directed Restriction Enzyme Cleavage of Specific ds-DNA Sequences

Two examples are used to demonstrate the ability of APEX devices to selectively carry out restriction endonuclease cleavage of ds-DNA sequences. The M13mp18 (having a Xba I restriction site) and M13mp8 (not having Xba I restriction site) vectors are used in these examples. These vectors are commonly used in many cloning and DNA sequencing procedures.

The first example demonstrates: (1) the electronic hybridization of M13mp sequences to specific micro-locations on the test device, (2) the free field electrophoretic transport of the Xba I restriction enzyme to the micro-locations, and (3) the subsequent capture of

the cleaved fragments at other micro-locations. The example also demonstrates the ability of the device to self-assemble itself with specific binding entities (oligonucleotide capture sequences, etc.).

5 The basic steps in the procedure are shown in Figure (16). Four specific micro-locations (ML-1, ML-2, ML-3, and ML-4) which covalently bind oligonucleotide capture sequences are used in the procedure. Electronic delivery systems are used to deliver reagents (oligonucleotides,
10 restriction enzyme, etc.) and for disposal of reactants.

 The first step involves the transport and covalent attachment of the M13-1 oligonucleotide capture sequence to ML-1 and ML-2 micro-locations, and the transport and attachment of the M13-2 oligonucleotide capture sequence to
15 ML-3 and ML-4 micro-locations. Since nucleic acids are negatively charged at $\text{pH} > 4$, they always move toward the positively charged electrode when electrophoresed in buffer solutions which range from $\text{pH} 5-9$.

 The second step involves the free field
20 electrophoretic transport and hybridization of the M13mp18 sequence to the M13-1 capture sequence at ML-1 micro-location, and the M13mp8 sequence to the M13-1 sequence at the ML-2 micro-location.

 The third step involves the transport of the XbaI
25 restriction enzyme to the ML-1 (M13mp18) micro-location and the ML-2 (M13mp8) micro-location. The Xba I cleaves the M13mp18 at ML-1, but not the M13mp8 at ML-2. The cleaved fragments from ML-1 are transported and hybridized to the M13-2 sequence at ML-3. As an experimental control, free
30 field electrophoresis is carried out between ML-2 and ML-4. Since the M13mp8 sequence at ML-2 has not been cleaved, no fragment is detected at ML-4.

The various M13 attachment and probe sequences used in this example are prepared as previously described in the specifications. These sequences are shown below:

M13-C1 5'-CCA GTC ACG ACG TTG TAA AAC GAC GGC CAG U

5 M13-C2 5'-GTA ATC ATG GTC ATA GCT GTT TCC TGT GTG U

MP18-40C 5'-GCA TGC CTG CAG GTC GAC TCT AGA GGA TCC CCG-
GGT ACC G

MP8-40C 5'-TGC CAA GCT TGG CTG CAG GTC GAC GGA TCC- CCG
GGA ATT C

10 MP18-R1 (TR)-5'-AAA TTG TTA TCC GCT CAC AAT TGC

MP8-R2 (F)-5'-ACA CAA CAT ACG AGC CGG AAG CAT

Step 1 - Attachment of M13 Capture Sequences

An APEX test device with 200 μ m micro-locations of amine activated highly cross-linked (26%) polyacrylamide surface or polycarbonate (5-10 nm) porous membrane surface is used for this procedure.

The M13-C1 capture sequence is a 31-mer DNA oligonucleotide containing a 3'-ribonucleotide. The M13-C1 sequence is complimentary to the 3'-terminal of the M13mp18 and M13mp8 single-stranded (+) vectors. The M13-C1 capture sequence is designed to hybridize and strongly bind all un-cleaved M13 vectors.

The M13-C2 sequence is a 31-mer oligonucleotide containing a 3'-ribonucleotide. The M13-C2 is complementary to a portion of the M13 sequence upstream from the cloning site containing the Xba I restriction site. The M13-C2 capture sequence is designed to hybridize and strongly bind the Xba I cleaved M13 fragments.

The M13-C1 and M13-C2 capture sequences are activated for coupling to the amine derivatives on the APEX micro-locations by the paraded oxidation. The 3' ribonucleotide terminus is converted to a terminal dialdehyde by the
5 paraded oxidation method which can react with primary amines to form a Schiff's base.

Reaction conditions are as follows:

Dissolve 10-20 O.D. of the M13-C1 or M13-C2 oligomer in water to a final concentration of 1 OD/ μ l. Add 1 volume
10 of 0.1M sodium acetate, pH 5.2 and 1 vol 0.45M sodium paraded (made fresh in water). Stir and incubate reaction for at least 2 hours at ambient temperature, in the dark. Load reaction mix onto a Sephadex G-10 column (pasteur pipette, 0.6 X 5.5 cm) equilibrated in 0.1M sodium
15 phosphate, pH 7.4. Collect 200 μ l fractions, spot 2 μ l aliquots on thin layer chromatography (TLC) and pool ultra violet (UV) absorbing fractions.

Four top surfaces of the APEX test devices are designated to be the addressable micro-locations ML-1, ML-
20 2, ML-3, and ML-4.

M13-C1 is covalently attached to the ML-1 and ML-2 micro-locations by the following procedure:

The upper and lower reservoirs are filled with 0.1 M sodium phosphate, pH 7.4 and prerun for 5 minutes at 0.05
25 mA constant current, using a BioRad 500/1000 power supply. The tip of an electronic delivery system containing ~ 0.1 O.D. units of the paraded oxidized M13-C1 oligonucleotide is placed into the lower reservoir. The electronic
30 delivery system is a specially modified plastic pipet tip with a platinum electrode inside. The electronic delivery system is biased negative (-) and micro-locations ML-1 and ML-2 are biased positive (+) at 0.1 mA. M13C-1 is electrophoresed to ML-1 and ML-2 for 2 minutes at constant

current, where it becomes covalently bound to the surface. The polarity is reversed, for ~ 4 minutes, so that unreacted M13C-1 is removed from the ML-1 and ML-2 micro-locations.

- 5 The M13C-2 sequence is attached to the ML-3 and ML-4 micro-locations with the same procedure described above.

Step 2 - Hybridization of M13 Vectors, Complementary Sequences, and Fluorescent Reporter Probes

- 10 Since restriction endonucleases require double-stranded DNA for cleavage, the cloning/restriction site segments of the single stranded M13mp18 (from 6240 to 6280) and M13mp8 (from 6230 to 6270) must be hybridized with complementary DNA sequences. Electronic hybridization is used to hybridize a 40-mer complementary fragment (MP18-40C
15 sequence) to M13mp18 vector on ML-1/M13C-1 micro-location; and to hybridize a 40-mer complementary fragment (MP8-40C sequence) to the M13mp8 vector on ML-2/M13C-1 micro-location respectively.

- 20 Electronic hybridization is carried out by negatively (-) biasing an electronic delivery system containing 0.05 O.D. units of M13mp18, and positively (+) biasing the ML-1/MP13C-1 micro-location at 0.1 mA for 2 minutes. The polarity is reversed for 4 minutes and the un-hybridized M13mp18 is removed from the micro-location. The same
25 procedure is used to electronically hybridize the M13mp8 vector to the ML-1/M13C-1 micro-location.

- 30 The M13mp18 and M13mp8 sequences are then electronically hybridized with two different fluorescent reporter probes. The M13mp18 vector on the ML-1/M13C-1 micro-location is electronically hybridized with a 24-mer Texas Red labelled reporter probe (MP18-R1 sequence), which hybridizes to the 5'-terminal of the cloning/restriction

sites. The M13mp8 vector is electronically hybridized with a 24-mer Fluorescein labelled reporter probe (MP8-R2 sequence), which hybridizes to the 5'-terminal of the cloning/restriction sites.

5 Step 3 - Restriction Cleavage of the M13mp18 Vector
Using the Xba I Restriction Enzyme

Depending upon their Isoelectric Point (pI), many proteins and enzymes can be negatively charged ($\text{pH} > \text{pI}$), neutral ($\text{pH} = \text{pI}$), or positively charged ($\text{pH} < \text{pI}$) in the
10 pH 5-9 range. A number of restriction endonucleases have pI's in the 6-7 range. At pH's greater than the pI, these enzymes will carry a net negative charge. Therefore, when free field electrophoresis is carried out in a buffered solution with a $\text{pH} > 7$, these enzymes will migrate to the
15 positively charged micro-location.

In the case of many DNA modifying enzyme, like restriction endonuclease, it is always desirable to choose a buffer solution which provides a pH which balances the optimal enzyme activity with relatively fast
20 electrophoretic mobility. In some cases it is possible to have reasonable enzyme activity both above and below the pI. These enzymes can be moved toward either a positively or negatively biased micro-location, depending on the chosen pH.

25 The Xba I cleavage of the M13mp18 vector at ML-1 is carried out as follows. The Xba I endonuclease is first free field electrophoresed to the ML-1/M13mp18 micro-location using an electronic delivery system. The electronic delivery system, containing 100 units of Xba I
30 in pH 7.6 buffer, is biased negative and the ML-1/M13mp18 micro-location is biased positive at 0.1 mA for 2 minutes. The current is then reduced to 0.02 mA for 3 minutes. The

electronic delivery system is turned off, while the ML-1/M13mp18 micro-location is biased negative and the ML-3/M13C-2 micro-location is biased positive at 0.1 mA for 5 minutes. The ML-3/M13C-2 micro-location is now biased
5 negative and the electronic delivery system is turned on and biased positive at 0.1 mA for 2 minutes in order to remove Xba 1 and un-hybridized fragments from the ML-3/M13C-2 micro-location.

Observation by epifluorescent microscopy shows loss of
10 red fluorescent signal at the ML-1/M13mp18 micro-location and presence of red fluorescent signal at the ML-3/M13C-2 micro-locations, demonstrating Xba 1 cleavage of the M13mp18 vector. The same basic Xba 1 cleavage procedure is now repeated for the ML-2/M13mp8 micro-location, which
15 serves as a negative control. Since the M13mp8 vector has no Xba 1 site, cleavage and production of fragments is not possible. The ML-2/M13mp18 micro-location thus maintains its green fluorescent signal, and no fluorescent signal is observed at ML-4/M13C-2 micro-location.

20 A second example involves restriction cleavage reactions being carried out with the restriction enzymes being covalently attached to addressable micro-locations on the device. In this case, restriction endonucleases would be derivatized and free field electrophoresed to
25 addressable micro-locations on an APEX device where they would become covalently bound. Methods for the derivatization and covalent attachment of restriction enzymes to solid supports are known to those skilled in the art. A variety of different restriction enzymes could be
30 addressed to the APEX device. Specific cleavage reactions would be carried out by using free field electrophoresis to concentrate ds-DNA vectors or DNA samples at the micro-location containing the desired restriction endonuclease.

The ds-DNA would be cleaved and fragments then moved to other micro-locations on the device. When desired or useful other DNA modifying enzymes could be coupled to addressable micro-locations on the APEX device. Also, this example should not be considered limited to DNA modifying enzymes, in that most other enzymes could be attached to addressable micro-locations on APEX devices.

EXAMPLE 12: Electronic Amplification Methods

In cases of hybridization analysis with very low target sequence copy number (e.g., HIV, septic blood infections, etc.), the multiplication or amplification of target DNA sequence would enable sensitivity to be improved by amplification of purified target DNA and/or RNA directly on an APEX device. Amplification would also reduce the requirement for very high yield preparative steps prior to hybridization analysis.

APEX amplification protocol provides complete electronic control of DNA movements, denaturation, and synthesis reactions. Most importantly DNA hybrids are denatured electronically without the use of high temperature or the need for thermophilic polymerases or other thermal stable enzymes.

As a first example, DNA synthesis can be achieved with high fidelity using DNA polymerase (Klenow large fragment) and without the need for thermal cycling. In this example, one DNA strand is amplified in a way that leaves it covalently bound to a micro-location. The procedure is carried out in the following manner: 1) the known target sequence is electronically hybridized to a capture probe of known sequence on an addressed micro-location, 2) synthesis of nascent complementary strand DNA (-) by DNA polymerase primed by the capture probe is carried out, 3) the newly

synthesized DNA hybrids are electronically denatured, 4) annealing of target strand DNA to non-elongated capture probe and annealing of - strand complementary probe to nascent - strand DNA is carried out, 5) the synthesis of nascent target strand DNA(+) by DNA polymerase and concomitant synthesis of - strand DNA as in 2 is carried out, thereby doubling the number of + and - strands each time these steps are repeated, and 6) size selection of amplified target is carried out by hybridization to a specially designed complimentary probe. The complete procedure, shown in Figure 17, is described in more detail below:

Step 1) Attachment of Target Sequence to Capture Probe

Target sequence is electrophoretically transported to a micro-location (1) containing covalently bound capture probe. Target sequence can be present in a background of non-target (genomic) sequence but must be denatured prior to annealing to capture probe. Target sequence which is initially captured will be of variable length.

Step 2) Synthesis of DNA Complementary to Target

DNA polymerase and dNTP's are electrophoretically transported to micro-location 1. The capture probe provides a 3' end for DNA polymerase and the captured target sequence provides the template. Current sufficient to maintain a concentration of reagents amenable to synthesis are applied. The current may be constant or pulsed. These parameters can be manipulated to obtain differing ranges of lengths of nascent complementary (-) strand.

Step 3) Electronic Denaturation of Newly Synthesized Strands

Polarity at micro-location 1 is reversed and voltage is applied to separate the two strands. The amount of voltage and the time period of application will be dependent on the length and base composition of the hybrid DNA complex. These parameters may be determined empirically or calculated from electronic denaturation curves.

10 Step 4) Annealing of Primers (Capture and complementary Probes) to DNA Strands

Oligos need to be annealed to both + and - DNA strands to provide primer sites for DNA polymerase. For the target or + strand this is accomplished by electrophoretic transport of + strand to un-elongated capture probe. This will occur as long as un-elongated capture probe is in excess to elongated, covalently bound - strand DNA. Complementary probe is electrophoresed to the micro-location and binds to covalently bound - strand DNA. Now both + and - strands have primer bound to them and are templates DNA polymerase catalyzed synthesis (see figure). Binding of complementary probe may also occur with noncovalently bound - strand DNA, however these hybrids will not be electronically denatured and therefore should have little impact on the overall amplification.

25 Step 5) Synthesis of Two New Strands of DNA

Step 2 is repeated and since both + and - strands are primed templates, the amount of sequence specific DNA doubles. This geometric increase in the amount of DNA will occur each time these steps are repeated.

Step 6) Size Selection of Amplified Target Sequence

The nucleotide sequence of the complementary probe will determine the size and sequence of the amplified target DNA. Therefore, the amplified DNA can be custom
5 designed to enhance efficiency in subsequent analysis and/or manipulation.

Other enzymes can be used in the amplification method of this invention, including, but not limited to, other DNA polymerases, T7 or SP6 RNA polymerases, reverse
10 transcriptases, DNA ligases, and polynucleotide phosphorylases, and combinations of other nucleic acid modifying enzymes (endonucleases, exonucleases, etc.).

EXAMPLE 13: Electronic Controller And Data System

All devices, whether APEX chip or micromachined
15 devices, will be of the nature of an addressable array of micro-locations (or macro-locations). A computer control/data collection system has been designed to provide independent application of electric potentials to any pads in the array and to measure the resulting current flowing
20 in the microlocation-electrolyte system. The computer control/data collection interface provides:

a) Representation of the array of micro-locations. Higher level and lower level representations provide views of all micro-locations, with resolution of blocks of micro-
25 locations at the highest level view, and with fully resolved blocks of micro-locations at the lower levels.

b) Clicking on a micro-location will pop-up a window view of the micro-location detailing the characterization of the micro-location, allowing setting of control of the
30 micro-location with a time sequence of signals of various shape, electric potential magnitude and sign, etc., display of the control sequence overlaying that of other micro-

locations, etc. The system also provides display of the data and signals collected for the micro-location with statistics and comparisons with data from other micro-locations. Menus provide analysis, documentation and archival functions for the control design, the actual control signals observed and the data collected.

- 5 c) The software provides all switching and data collection through a hardware interface controlled by inputs from the array control software described in b).
- 10 d) A separate hardware and software system provides image collection and processing capabilities. This system images the array of micro-locations and records fluorescence signals from DNA binding interactions at the active micro-locations to provide readout of the DNA binding experimental results. Image processing software provides the ability to quantitatively process these images and extract quantitative assay results. This software is fully interfaced with the array controller/data collection software to provide an integrated system that records all
- 15 the APEX device control/electrolyte current data and the assay results from imaging data, analyzes the data to provide reduced results for the assay along with ancillary information regarding the consistency and reliability of these results, and archive all the data and analyses.
- 20 e) An APEX controller will incorporate all of this software plus a top layer that provides only "DO ASSAY" and "RESULTS" displays, plus a button to access a) through c) functionality if necessary, but a) through c) will be collected and archived in all cases.
- 25 f) The initial version of the controller to be used for development projects uses a Macintosh Quadra 950 as a host computer and uses National Instruments boards interfaced with the Quadra 950 to provide the hardware interface
- 30

described above. These boards apply the variable potentials to the APEX micro-locations and measure the resulting current flowing in the electrolyte system. The National Instruments boards used in this controller are the

5 High Resolution Multifunction I/O board, NB-MIO-16XL-18, the Analog Output board, NB-AO-6, the Timing Input/Output board, NB-TIO-10, the Block Mode DMA and GPIB Interface board, NB-DMA2800, and the Analog Signal Conditioning Modules boards and Modules for thermocouples, and other

10 environmental sensors, 5B series. Connections between the NuBus boards in the Quadra and the APEX device will be through SCXI 16-Channel SPDT Relay Module boards housed in an SCXI-1001 Chassis.

EXAMPLE 14: Electronically Controlled Sample Preparation and Hybridization Analysis - An Integrated APEX System

15

Sample preparation usually involves selection of cells; disruption of cellular material (e.g., lysis), and a series of separation procedures and affinity reactions. Sample preparation is important for molecular biologic

20 reactions. For example, hybridization assay is often limited because one loses significant amounts of the actual target DNA sequences due to inefficiencies in the sample preparation process.

The basic APEX concept for electronic control can be

25 used for sample preparation in DNA hybridization assays. Electronic methods will allow sample preparation, cell selection and analysis to be carried out on an active electronic system of APEX components. The sample preparation would begin with cell selection and lysis, and

30 the gross separation of DNA from cellular and extraneous materials in the sample. The electronic device would electronically process the sample DNA and move it

efficiently toward the analytical component of the device, while removing the other materials. The system provides the proper scaling factor for efficient processing of the target DNA. For human genomic analysis, electronic sample
5 preparation would include a highly efficient pre-hybridization step by which most of the complex non-specific DNA would be separated from the target DNA.

An integrated device or complete APEX system with sample preparation would take a relatively crude sample
10 (blood, sputum, urine, etc.), and processes it with minimum mechanical manipulation and fluidics, and then electronically deliver target DNA to the analytical component of the device. This "active electronic processing" differs from automation or robotic processing,
15 which are generally mechanical versions of the manual process and techniques.

An integrated APEX System for DNA sample preparation and analysis can be fabricated using a number of components all based on the general APEX concept. The components of
20 the system include (1) an electronic cell selector unit; (2) an electronic reagent dispenser unit; (3) an electronic waste disposal unit; (4) a crude DNA selector unit; (5) a secondary DNA or restriction fragment selector unit; (6) a DNA fragment storage unit; and (7) the APEX analytical unit
25 (chip). The integrated APEX system is shown in Figure 18.

Such a system can be fabricated on a large silicon wafer. Alternatively, individual components can be fabricated by microlithography or micromachining techniques and arranged on (e.g., plugged into) a specially designed
30 platform unit. The components of the complete system are designed so their active area scales to the relative sample size and the amount of materials in the sample (such as cells). For example, the cell selector active area

generally would be larger than the crude DNA selector active area, which in turn would be larger than the restriction fragment selector active area, which would be larger than the APEX analytical chip active area.

5 By way of example, the cell selector "active area" could be of the order of several cm^2 , while the total "active area" for a 64 micro-location APEX analytical component would be less than one mm^2 . The platform unit is designed to hold all the component units in a sealed common
10 buffer reservoir. Up to several hundred microliter of the appropriate sample is added to the system through a sample addition port near the cell selector component. The cell selector component is a larger scale APEX device which can have one or more selected affinities for different cell
15 types. These affinity selections can be made on the basis of cell surface charge, haptens, and antigens.

By way of example, affinity selection for whole blood samples can be made to select white blood cells (lymphocytes, etc.) from red blood cells. Highly selective
20 processes could be used to select fetal cells from material blood sample. It is also possible to provide affinity selection for infectious microorganisms (yeast, fungus, bacteria, and virus). While selected cells remain attached to the cell selector component; all other cells and
25 proteinaceous materials are transported to the waste disposal unit. At this point the cells can be lysed by free field electrophoretic transport of charged detergents, and/or chaotropic agents, and/or appropriate lytic enzymes and proteinases (lysozyme, proteinase K, pepsin, etc.) from
30 the electronic reagent dispenser unit to the cells on the cell selector unit. Appropriate biasing of the electronic waste disposal system can be used to remove certain lytic waste materials. The positive biasing of the crude DNA

selector unit can now be used to transport the crude nucleic acid (DNA/RNA) materials to this component.

The crude DNA selector is an APEX device which has a general affinity for DNA. This affinity can be a
5 positively charged surface, or a surface which contains a common or repetitive DNA sequence. For example, an Alu repeat capture sequence would effectively capture most of the crude DNA extracted from human cells. A common or generic bacteria or viral sequence could be used when
10 infectious disease analysis is the objective. In addition to removing extraneous materials from the DNA; the APEX system is also designed to reduce the complexity of the sample DNA. This can be achieved by using restriction enzymes to selectively cleave the DNA at the crude DNA
15 selector unit. The restriction enzymes are transported from the reagent dispenser unit. The cleaved restriction fragments can now be transported from to the secondary DNA or restriction fragment selector unit by biasing it positive. This unit is designed to selectively bind large
20 fragments of DNA, using appropriate capture sequences on its surface.

At this point, selected DNA fragments can be transported to the APEX analytical chip for hybridization analysis. It is also possible to transport DNA fragments
25 to the storage unit or even out of the system. The examples above represent just some of the possible scenarios for sample preparation and multiple hybridization analysis. The binding affinity programmability of components and flexibility of combining different
30 components and functions allows a wide variety of procedures to be carried out.

While DNA is used as a primary example, the above described device and method can also be used for the

processing and analysis of target RNA molecules, proteins, polysaccharides, lipids and other macromolecules.

All publications referenced are hereby incorporated by reference herein, including the nucleic acid sequences and
5 amino acid sequences listed in each publication.

Other embodiments are within the following claims.

SEQUENCE LISTING

(1) GENERAL INFORMATION:

(i) APPLICANT: Michael J. Heller
Eugene Tu
Glen A. Evans
Ronald G. Soanowski

(ii) TITLE OF INVENTION: SELF-ADDRESSABLE SELF-ASSEMBLING
MICROELECTRONIC SYSTEMS AND DEVICES FOR
MOLECULAR BIOLOGICAL ANALYSIS AND

DIAGNOSTICS

(iii) NUMBER OF SEQUENCES: 45

(iv) CORRESPONDENCE ADDRESS:

(A) ADDRESSEE: Lyon & Lyon
(B) STREET: 611 West Sixth Street
(C) CITY: Los Angeles
(D) STATE: California
(E) COUNTRY: USA
(F) ZIP: 90017

(v) COMPUTER READABLE FORM:

(A) MEDIUM TYPE: 3.5" Diskette, 1.44 Mb storage
(B) COMPUTER: IBM Compatible
(C) OPERATING SYSTEM: IBM P.C. DOS (Version 5.0)
(D) SOFTWARE: WordPerfect (Version 5.1)

(vi) CURRENT APPLICATION DATA:

(A) APPLICATION NUMBER: 08/271,882
(B) FILING DATE: July 7, 1994
(C) CLASSIFICATION:

(vii) PRIOR APPLICATION DATA:

(A) APPLICATION NUMBER: 08/146,504
(B) FILING DATE: November 1, 1993

(viii) ATTORNEY/AGENT INFORMATION:

(A) NAME: Murphy, David B.
(B) REGISTRATION NUMBER: 31,125
(C) REFERENCE/DOCKET NUMBER: 207/263

(ix) TELECOMMUNICATION INFORMATION:

(A) TELEPHONE: (213) 489-1600
(B) TELEFAX: (213) 955-0440
(C) TELEX: 67-3510

(2) INFORMATION FOR SEQ ID NO: 1:

(i) SEQUENCE CHARACTERISTICS:

(A) LENGTH:	24
(B) TYPE:	nucleic acid
(C) STRANDEDNESS:	single
(D) TOPOLOGY:	linear

(ii) SEQUENCE DESCRIPTION: SEQ ID NO: 1:

GCT ACG CCC TGC TCA TGA GTC TCU 24

(2) INFORMATION FOR SEQ ID NO: 2:

(i) SEQUENCE CHARACTERISTICS:

(A) LENGTH:	21
(B) TYPE:	nucleic acid
(C) STRANDEDNESS:	single
(D) TOPOLOGY:	linear

(ii) SEQUENCE DESCRIPTION: SEQ ID NO: 2:

AAA AAA AAA AAA AAA AAA AAU 21

(2) INFORMATION FOR SEQ ID NO: 3:

(i) SEQUENCE CHARACTERISTICS:

(A) LENGTH:	34
(B) TYPE:	nucleic acid
(C) STRANDEDNESS:	single
(D) TOPOLOGY:	linear

(ii) SEQUENCE DESCRIPTION: SEQ ID NO: 3:

CTA CGT GGA CCT GGA GAG GAA GGA GAC TGC CTG U 34

(2) INFORMATION FOR SEQ ID NO: 4:

(i) SEQUENCE CHARACTERISTICS:

(A) LENGTH:	20
(B) TYPE:	nucleic acid
(C) STRANDEDNESS:	single
(D) TOPOLOGY:	linear

(ii) SEQUENCE DESCRIPTION: SEQ ID NO: 4:

GAG TTC AGC AAA TTT GGA GU 20

106

(2) INFORMATION FOR SEQ ID NO: 5:

(i) SEQUENCE CHARACTERISTICS:

(A) LENGTH:	20
(B) TYPE:	nucleic acid
(C) STRANDEDNESS:	single
(D) TOPOLOGY:	linear

(ii) SEQUENCE DESCRIPTION: SEQ ID NO: 5:

CGT AGA ACT CCT CAT CTC CU 20

(2) INFORMATION FOR SEQ ID NO: 6:

(i) SEQUENCE CHARACTERISTICS:

(A) LENGTH:	18
(B) TYPE:	nucleic acid
(C) STRANDEDNESS:	single
(D) TOPOLOGY:	linear

(ii) SEQUENCE DESCRIPTION: SEQ ID NO: 6:

GTC TCC TTC CTC TCC AGU 18

(2) INFORMATION FOR SEQ ID NO: 7:

(i) SEQUENCE CHARACTERISTICS:

(A) LENGTH:	20
(B) TYPE:	nucleic acid
(C) STRANDEDNESS:	single
(D) TOPOLOGY:	linear

(ii) SEQUENCE DESCRIPTION: SEQ ID NO: 7:

GAT GAG CAG TTC TAC GTG GU 20

(2) INFORMATION FOR SEQ ID NO: 8:

(i) SEQUENCE CHARACTERISTICS:

(A) LENGTH:	18
(B) TYPE:	nucleic acid
(C) STRANDEDNESS:	single
(D) TOPOLOGY:	linear

(ii) SEQUENCE DESCRIPTION: SEQ ID NO: 8:

CTG GAG AAG AAG GAG ACU 18

(2) INFORMATION FOR SEQ ID NO: 9:

(i) SEQUENCE CHARACTERISTICS:

(A) LENGTH:	22
(B) TYPE:	nucleic acid
(C) STRANDEDNESS:	single
(D) TOPOLOGY:	linear

(ii) SEQUENCE DESCRIPTION: SEQ ID NO: 9:

TTC CAC AGA CTT AGA TTT GAC U 22

(2) INFORMATION FOR SEQ ID NO: 10:

(i) SEQUENCE CHARACTERISTICS:

(A) LENGTH:	20
(B) TYPE:	nucleic acid
(C) STRANDEDNESS:	single
(D) TOPOLOGY:	linear

(ii) SEQUENCE DESCRIPTION: SEQ ID NO: 10:

TTC CGC AGA TTT AGA AGA TU 20

(2) INFORMATION FOR SEQ ID NO: 11:

(i) SEQUENCE CHARACTERISTICS:

(A) LENGTH:	20
(B) TYPE:	nucleic acid
(C) STRANDEDNESS:	single
(D) TOPOLOGY:	linear

(ii) SEQUENCE DESCRIPTION: SEQ ID NO: 11:

TGT TTG CCT GTT CTC AGA CU 20

(2) INFORMATION FOR SEQ ID NO: 12:

(i) SEQUENCE CHARACTERISTICS:

(A) LENGTH:	20
(B) TYPE:	nucleic acid
(C) STRANDEDNESS:	single
(D) TOPOLOGY:	linear

(ii) SEQUENCE DESCRIPTION: SEQ ID NO: 12:

CAG CGC TGT GAC AAA ACA TU 20

(2) INFORMATION FOR SEQ ID NO: 13:

(i) SEQUENCE CHARACTERISTICS:

(A) LENGTH:	20
(B) TYPE:	nucleic acid
(C) STRANDEDNESS:	single
(D) TOPOLOGY:	linear

(ii) SEQUENCE DESCRIPTION: SEQ ID NO: 13:

TGC GAG CTG CAG TCA GAC AT 20

(2) INFORMATION FOR SEQ ID NO: 14:

(i) SEQUENCE CHARACTERISTICS:

(A) LENGTH:	18
(B) TYPE:	nucleic acid
(C) STRANDEDNESS:	single
(D) TOPOLOGY:	linear

(ii) SEQUENCE DESCRIPTION: SEQ ID NO: 14:

GAG AGA CTC ATG AGC AGG 18

(2) INFORMATION FOR SEQ ID NO: 15:

(i) SEQUENCE CHARACTERISTICS:

(A) LENGTH:	18
(B) TYPE:	nucleic acid
(C) STRANDEDNESS:	single
(D) TOPOLOGY:	linear

(ii) SEQUENCE DESCRIPTION: SEQ ID NO: 15:

CCT CGT CAT GAG TCT CTC 18

(2) INFORMATION FOR SEQ ID NO: 16:

(i) SEQUENCE CHARACTERISTICS:

(A) LENGTH:	19
(B) TYPE:	nucleic acid
(C) STRANDEDNESS:	single
(D) TOPOLOGY:	linear

(ii) SEQUENCE DESCRIPTION: SEQ ID NO: 16:

TTT TTT TTT TTT TTT TTT T 19

(2) INFORMATION FOR SEQ ID NO: 17:

(i) SEQUENCE CHARACTERISTICS:

(A) LENGTH:	33
(B) TYPE:	nucleic acid
(C) STRANDEDNESS:	single
(D) TOPOLOGY:	linear

(ii) SEQUENCE DESCRIPTION: SEQ ID NO: 17:

CAG GCA GTC TCC TTC CTC TCC AGG TCC ACG TAG 33

(2) INFORMATION FOR SEQ ID NO: 18:

(i) SEQUENCE CHARACTERISTICS:

(A) LENGTH:	19
(B) TYPE:	nucleic acid
(C) STRANDEDNESS:	single
(D) TOPOLOGY:	linear

(ii) SEQUENCE DESCRIPTION: SEQ ID NO: 18:

CTC CAA ATT TGC TGA ACT C 19

(2) INFORMATION FOR SEQ ID NO: 20:

(i) SEQUENCE CHARACTERISTICS:

(A) LENGTH:	19
(B) TYPE:	nucleic acid
(C) STRANDEDNESS:	single
(D) TOPOLOGY:	linear

(ii) SEQUENCE DESCRIPTION: SEQ ID NO: 20:

GGA GAT GAG GAG TTC TAC G 19

(2) INFORMATION FOR SEQ ID NO: 21:

(i) SEQUENCE CHARACTERISTICS:

(A) LENGTH:	17
(B) TYPE:	nucleic acid
(C) STRANDEDNESS:	single
(D) TOPOLOGY:	linear

(ii) SEQUENCE DESCRIPTION: SEQ ID NO: 21:

CTG GAG AGG AAG GAG AC 17

(2) INFORMATION FOR SEQ ID NO: 22:

(i) SEQUENCE CHARACTERISTICS:

(A) LENGTH:	19
(B) TYPE:	nucleic acid
(C) STRANDEDNESS:	single
(D) TOPOLOGY:	linear

(ii) SEQUENCE DESCRIPTION: SEQ ID NO: 22:

CCA CGT AGA ACT GCT CAT C 19

(2) INFORMATION FOR SEQ ID NO: 23:

(i) SEQUENCE CHARACTERISTICS:

(A) LENGTH:	17
(B) TYPE:	nucleic acid
(C) STRANDEDNESS:	single
(D) TOPOLOGY:	linear

(ii) SEQUENCE DESCRIPTION: SEQ ID NO: 23:

GTC TCC TTC TTC TCC AG 17

(2) INFORMATION FOR SEQ ID NO: 24:

(i) SEQUENCE CHARACTERISTICS:

(A) LENGTH:	21
(B) TYPE:	nucleic acid
(C) STRANDEDNESS:	single
(D) TOPOLOGY:	linear

(ii) SEQUENCE DESCRIPTION: SEQ ID NO: 24:

GTC AAA TCT AAG TCT GTG GAA 21

(2) INFORMATION FOR SEQ ID NO: 25:

(i) SEQUENCE CHARACTERISTICS:

(A) LENGTH:	19
(B) TYPE:	nucleic acid
(C) STRANDEDNESS:	single
(D) TOPOLOGY:	linear

(ii) SEQUENCE DESCRIPTION: SEQ ID NO: 25:

ATC TTC TAA ATC TGC GGA A 19

(2) INFORMATION FOR SEQ ID NO: 26:

(i) SEQUENCE CHARACTERISTICS:

(A) LENGTH:	19
(B) TYPE:	nucleic acid
(C) STRANDEDNESS:	single
(D) TOPOLOGY:	linear

(ii) SEQUENCE DESCRIPTION: SEQ ID NO: 26:

GTC TGA GAA CAG GCA AAC A 19

(2) INFORMATION FOR SEQ ID NO: 27:

(i) SEQUENCE CHARACTERISTICS:

(A) LENGTH:	19
(B) TYPE:	nucleic acid
(C) STRANDEDNESS:	single
(D) TOPOLOGY:	linear

(ii) SEQUENCE DESCRIPTION: SEQ ID NO: 27:

ATG TTT TGT CAC AGC GAT G 19

(2) INFORMATION FOR SEQ ID NO: 28:

(i) SEQUENCE CHARACTERISTICS:

(A) LENGTH:	30
(B) TYPE:	nucleic acid
(C) STRANDEDNESS:	single
(D) TOPOLOGY:	linear

(ii) SEQUENCE DESCRIPTION: SEQ ID NO: 28:

GGT GGT GGG CGC CGG CGG TGT GGG CAA GAU 30

(2) INFORMATION FOR SEQ ID NO: 29:

(i) SEQUENCE CHARACTERISTICS:

(A) LENGTH:	30
(B) TYPE:	nucleic acid
(C) STRANDEDNESS:	single
(D) TOPOLOGY:	linear

(ii) SEQUENCE DESCRIPTION: SEQ ID NO: 29:

GGT GGT GGG CGC CGT CGG TGT GGG CAA GAU 30

(2) INFORMATION FOR SEQ ID NO: 30:

(i) SEQUENCE CHARACTERISTICS:

(A) LENGTH:	15
(B) TYPE:	nucleic acid
(C) STRANDEDNESS:	single
(D) TOPOLOGY:	linear

(ii) SEQUENCE DESCRIPTION: SEQ ID NO: 30:

CC GCG GCC GCC ACA C 15

(2) INFORMATION FOR SEQ ID NO: 31:

(i) SEQUENCE CHARACTERISTICS:

(A) LENGTH:	15
(B) TYPE:	nucleic acid
(C) STRANDEDNESS:	single
(D) TOPOLOGY:	linear

(ii) SEQUENCE DESCRIPTION: SEQ ID NO: 31:

CC GCG GCA GCC ACA C 15

(2) INFORMATION FOR SEQ ID NO: 32:

(i) SEQUENCE CHARACTERISTICS:

(A) LENGTH:	15
(B) TYPE:	nucleic acid
(C) STRANDEDNESS:	single
(D) TOPOLOGY:	linear

(ii) SEQUENCE DESCRIPTION: SEQ ID NO: 32:

CC TGT GCA GCC ACA C 15

(2) INFORMATION FOR SEQ ID NO: 33:

(i) SEQUENCE CHARACTERISTICS:

(A) LENGTH:	30
(B) TYPE:	nucleic acid
(C) STRANDEDNESS:	single
(D) TOPOLOGY:	linear

(ii) SEQUENCE DESCRIPTION: SEQ ID NO: 33:

GGT GGT GGG CGC CGG CGG TGT GGG CAA GAU 30

(2) INFORMATION FOR SEQ ID NO: 34:

(i) SEQUENCE CHARACTERISTICS:

(A) LENGTH:	29
(B) TYPE:	nucleic acid
(C) STRANDEDNESS:	single
(D) TOPOLOGY:	linear

(ii) SEQUENCE DESCRIPTION: SEQ ID NO: 34:

GGT GGT GGG CGC CGG CGG TGT GGG CAA GA 29

(2) INFORMATION FOR SEQ ID NO: 35:

(i) SEQUENCE CHARACTERISTICS:

(A) LENGTH:	22
(B) TYPE:	nucleic acid
(C) STRANDEDNESS:	single
(D) TOPOLOGY:	linear

(ii) SEQUENCE DESCRIPTION: SEQ ID NO: 35:

TGC CCA CAC CGC CGG CGC CCA C 22

(2) INFORMATION FOR SEQ ID NO: 36:

(i) SEQUENCE CHARACTERISTICS:

(A) LENGTH:	22
(B) TYPE:	nucleic acid
(C) STRANDEDNESS:	single
(D) TOPOLOGY:	linear

(ii) SEQUENCE DESCRIPTION: SEQ ID NO: 36:

TGC CCA CAC CGA CGG CGC CCA C 22

(2) INFORMATION FOR SEQ ID NO: 37:

(i) SEQUENCE CHARACTERISTICS:

(A) LENGTH:	?
(B) TYPE:	nucleic acid
(C) STRANDEDNESS:	single
(D) TOPOLOGY:	linear

(ii) SEQUENCE DESCRIPTION: SEQ ID NO: 37:

TGC CCA CAC CAC CGA CGG TGC CCA C 22

(2) INFORMATION FOR SEQ ID NO: 38:

(i) SEQUENCE CHARACTERISTICS:

(A) LENGTH:	7
(B) TYPE:	nucleic acid
(C) STRANDEDNESS:	single
(D) TOPOLOGY:	linear

(ii) SEQUENCE DESCRIPTION: SEQ ID NO: 38:

ACA CCG C

7

(2) INFORMATION FOR SEQ ID NO: 39:

(i) SEQUENCE CHARACTERISTICS:

(A) LENGTH:	7
(B) TYPE:	nucleic acid
(C) STRANDEDNESS:	single
(D) TOPOLOGY:	linear

(ii) SEQUENCE DESCRIPTION: SEQ ID NO: 39:

ACA ACG C

7

(2) INFORMATION FOR SEQ ID NO: 40:

(i) SEQUENCE CHARACTERISTICS:

(A) LENGTH:	31
(B) TYPE:	nucleic acid
(C) STRANDEDNESS:	single
(D) TOPOLOGY:	linear

(ii) SEQUENCE DESCRIPTION: SEQ ID NO: 40:

CCA GTC ACG ACG TTG TAA AAC GAC GGC CAG U

31

(2) INFORMATION FOR SEQ ID NO: 41:

(i) SEQUENCE CHARACTERISTICS:

(A) LENGTH:	31
(B) TYPE:	nucleic acid
(C) STRANDEDNESS:	single
(D) TOPOLOGY:	linear

(ii) SEQUENCE DESCRIPTION: SEQ ID NO: 41:

GTA ATC ATG GTC ATA CGT GTT TCC TGT GTG U

31

(2) INFORMATION FOR SEQ ID NO: 42:

(i) SEQUENCE CHARACTERISTICS:

(A) LENGTH:	40
(B) TYPE:	nucleic acid
(C) STRANDEDNESS:	single
(D) TOPOLOGY:	linear

(ii) SEQUENCE DESCRIPTION: SEQ ID NO: 42:

GCA TGC CTG CAG GTC GAC TCT AGA GGA TCC CCG GGT ACC G 40

(2) INFORMATION FOR SEQ ID NO: 43:

(i) SEQUENCE CHARACTERISTICS:

(A) LENGTH:	40
(B) TYPE:	nucleic acid
(C) STRANDEDNESS:	single
(D) TOPOLOGY:	linear

(ii) SEQUENCE DESCRIPTION: SEQ ID NO: 43:

TGC CAA GCT TGG CTG CAG GTC GAC GGA TCC CCT GGA ATT C 40

(2) INFORMATION FOR SEQ ID NO: 44:

(i) SEQUENCE CHARACTERISTICS:

(A) LENGTH:	24
(B) TYPE:	nucleic acid
(C) STRANDEDNESS:	single
(D) TOPOLOGY:	linear

(ii) SEQUENCE DESCRIPTION: SEQ ID NO: 44:

AAA TTG TTA TCC GCT CAC AAT TGC 24

(2) INFORMATION FOR SEQ ID NO: 45:

(i) SEQUENCE CHARACTERISTICS:

(A) LENGTH:	24
(B) TYPE:	nucleic acid
(C) STRANDEDNESS:	single
(D) TOPOLOGY:	linear

(ii) SEQUENCE DESCRIPTION: SEQ ID NO: 45:

ACA CAA CAT ACG AGC AGC CCG AAG CAT 24

The claims defining the invention are as follows:

1. A method for electronically controlled synthesis of biopolymers on a plurality of locations, comprising the steps of:

- 5 providing a plurality of reaction locations on a substrate, wherein each reaction location is individually electronically addressable;
 providing an attachment layer upon each reaction location;
 contacting said plurality of reaction location with a solution comprising a charged monomer-A;

10 selectively biasing a designated A location at which reaction A is to occur at an opposite charge to monomer-A, and biasing another location at which no reaction A is to occur the same charge as monomer-A, thereby concentration and reacting monomer A on said A location;

thereafter, removing the unreacted monomer A from said plurality of reaction locations;

15 contacting said plurality of reaction locations with a solution comprising a charged monomer-B; and

selectively biasing said A location at the opposite charge of monomer-B, and biasing another location at which no reaction B is to occur the same charge as monomer-B, thereby concentrating and reacting monomer B on said A location to form dimer A-B.

20 2. The method of claim 1, wherein said monomer-A consists of a nucleotide and said monomer-B consists of a nucleotide.

3. The method of claim 1, wherein said monomer-A consists of an amino acid and said monomer-B consists of an amino acid.

25 4. The method of claim 1 for electronically controlled combinatorial synthesis of a biopolymer wherein at least one biopolymer includes an oligonucleotide.

5. The method of claim 4 for electronically controlling combinatorial synthesis of a biopolymer wherein the oligonucleotide is a deoxyribonucleic acid (DNA).

6. The method of claim 1 for electronically controlling the combinatorial synthesis of a biopolymer wherein at least one biopolymer includes a peptide.

30 7. The method of claim 1 for electronically controlling combinatorial synthesis of a biopolymer wherein at least one biopolymer is a complex polymer.

8. The method of claim 1 wherein said synthesis is water soluble synthesis.

9. The method of claim 7 wherein the water soluble synthesis includes charged monomers and enzymes.



10. A method for synthesising a plurality of polymers, the polymers being composed of monomers in selected positions, at a plurality of locations on an active, programmable electronic matrix device, comprising the steps of:

5 providing a selected charged reactant on the device adjacent the locations, synthesising the polymer by selectively:

 biasing those locations attractive to the charged reactant where the polymer includes a specified monomer at the selected position, and simultaneously

 biasing those locations repulsive to the charged reactant where the polymer does not include the specified monomer at said selected position,

10 selectively reacting the specific monomer, and

 repeating the above steps by sequentially providing charged reactants to the device, and biasing the locations attractive and repulsive to include or exclude, respectively, a monomer at the selected positions.

15 11. The method of claim 10 for synthesising a polymer wherein the charged reactant is a charged deblocking reagent.

12. The method of claim 11 for synthesising a polymer wherein after the charged deblocking reagent has been attracted to the location, the said specified monomer is provided at the location.

20 13. The method of claim 10 for synthesising a polymer wherein the charged reactant is a charged coupling reagent.

14. The method of claim 13 for synthesising a polymer wherein after the charged coupling reagent has been attracted to the location, the said monomer is provided at the location.

25 15. The method of claim 13 for synthesising a polymer wherein the charged coupling reagent is water soluble.

16. The method of claim 11 for synthesising a polymer wherein the charged reactant includes said specified monomer.

17. The method of claim 11 for synthesising a polymer wherein at least one polymer includes an oligonucleotide.

30 18. The method of claim 17 for synthesising a polymer wherein the oligonucleotide is DNA.

19. The method of claim 10 for synthesising a polymer wherein at least one polymer includes a peptide.

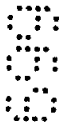
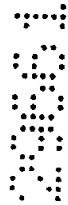

20. The method of claim 10 for synthesising a polymer wherein the polymer is a complex polymer.

21. The method of claim 10 for synthesising a polymer wherein the charged reactant has a net positive charge.

5 22. The method of claim 10 for synthesising a polymer wherein the charged reactant has a net negative charge.

23. The method of claim 10 for synthesising a polymer wherein the charged reactants are provided with a net charge.

10 24. The method of claim 10 for synthesising a polymer further including the step of removing the unreacted charged reactant.

25. The method of claim 10 for synthesising a polymer wherein the locations are selected to be microlocations.

26. The method of claim 10 for synthesising a polymer further including the step of electronically delivering reactants from an electronic reagent supply device.

15 27. The method of claim 10 wherein said synthesis is water soluble synthesis.

28. The method of claim 27 wherein the water soluble synthesis includes charged monomers and enzymes.

29. A method for electronically controlled synthesis of biopolymers on a plurality of locations, substantially as herein described with reference to the Examples and/or drawings.

20 30. Biopolymers synthesised by the method of any one of claims 1-9.

31. A method for synthesising a plurality of polymers, substantially as herein described with reference to the Examples and/or drawings.

25 32. Polymers synthesised by the method of claim 31.

Dated 9 June, 1999
Nanogen, Inc.

Patent Attorneys for the Applicant/Nominated Person
SPRUSON & FERGUSON

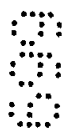
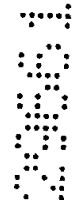

FIG. 1.

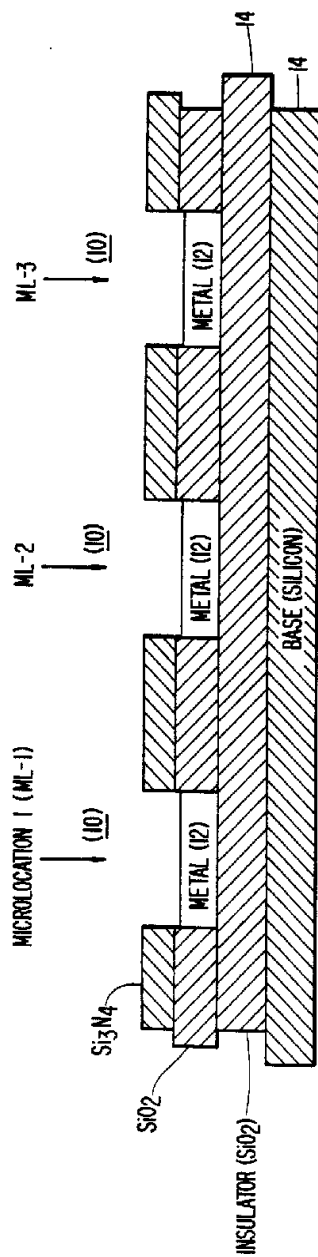

FIG. 2.

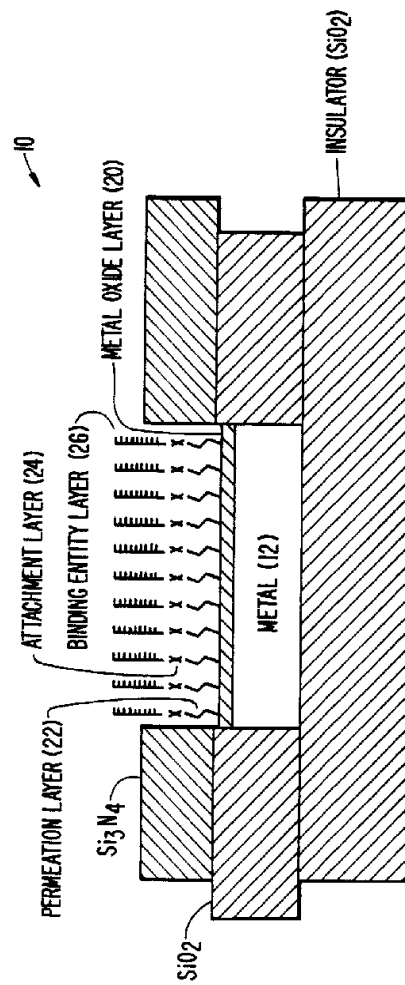
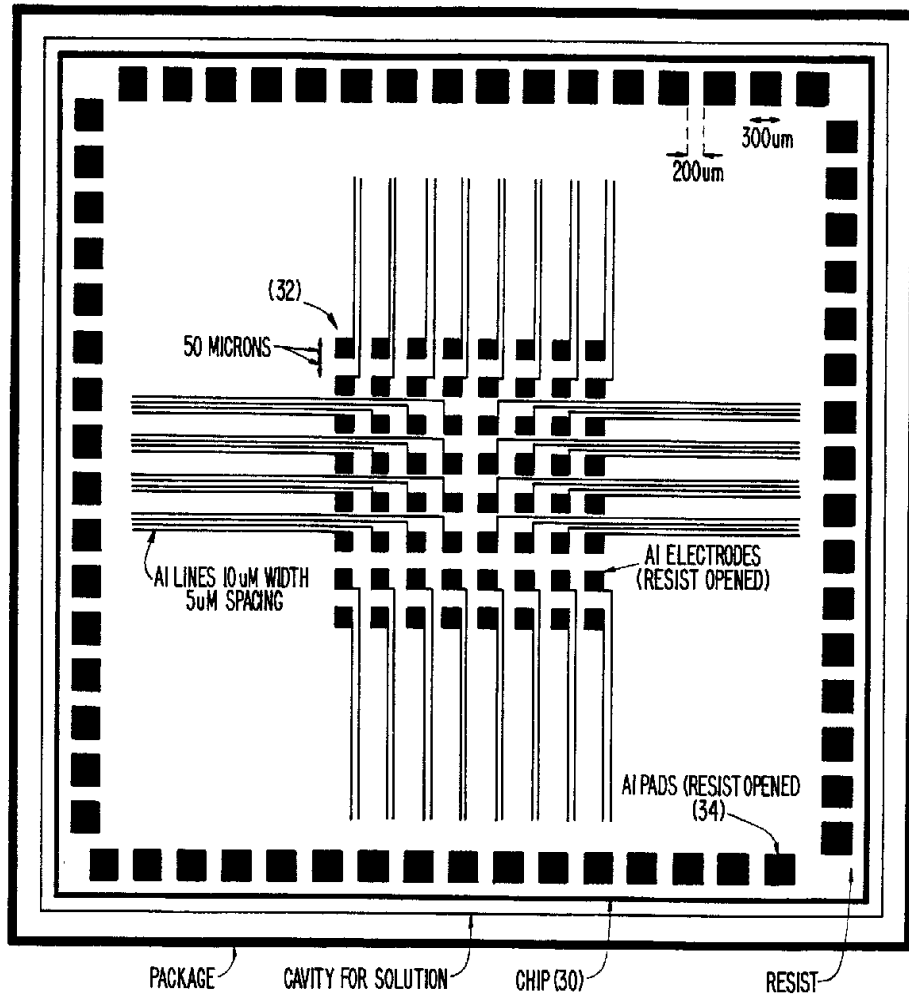
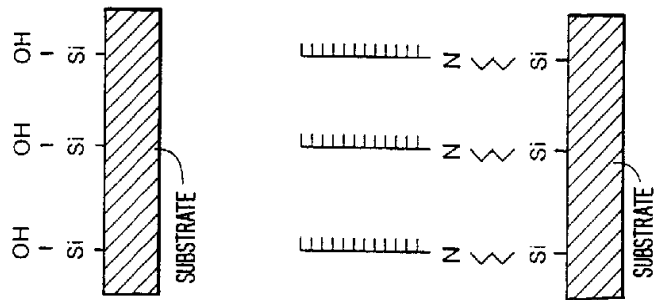
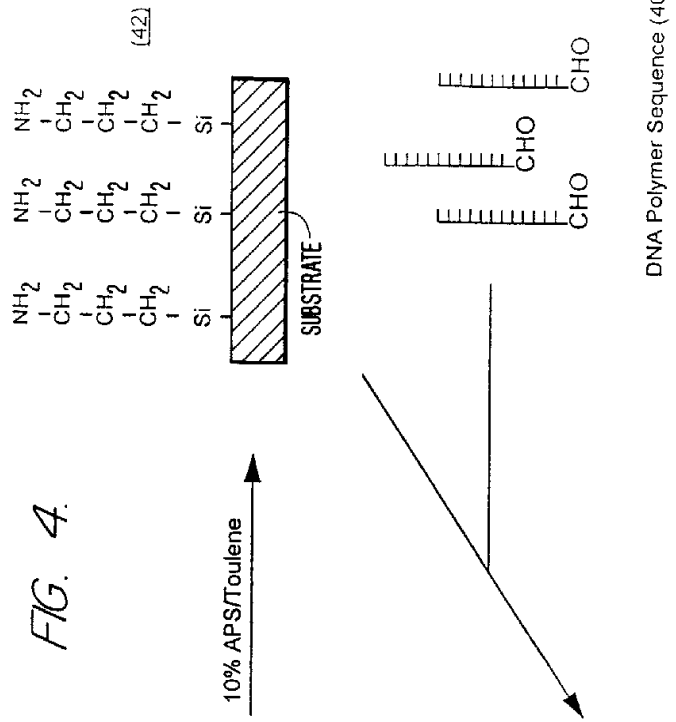

FIG. 3.



3/20



SUBSTITUTE SHEET (RULE 26)

FIG. 5.

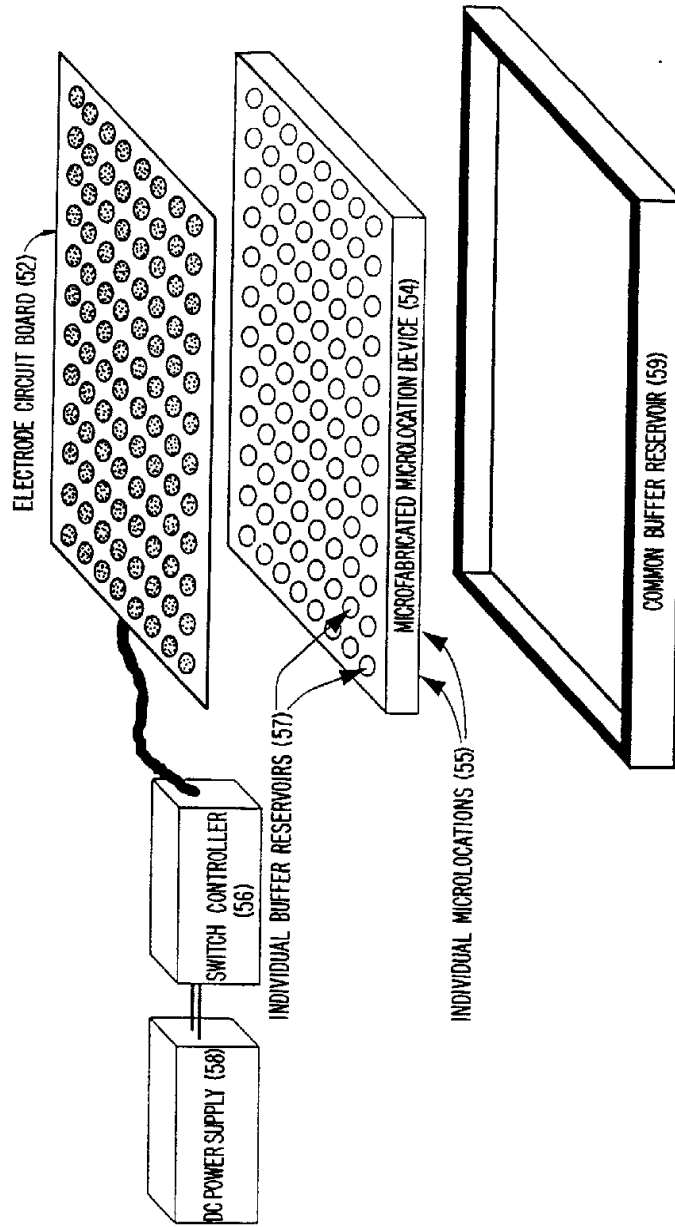
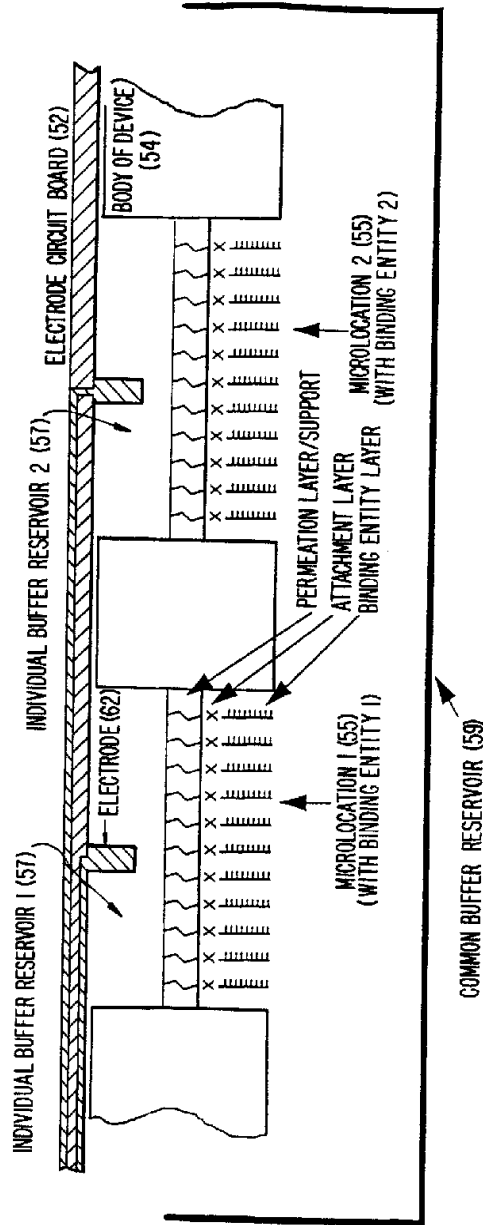

FIG. 6.



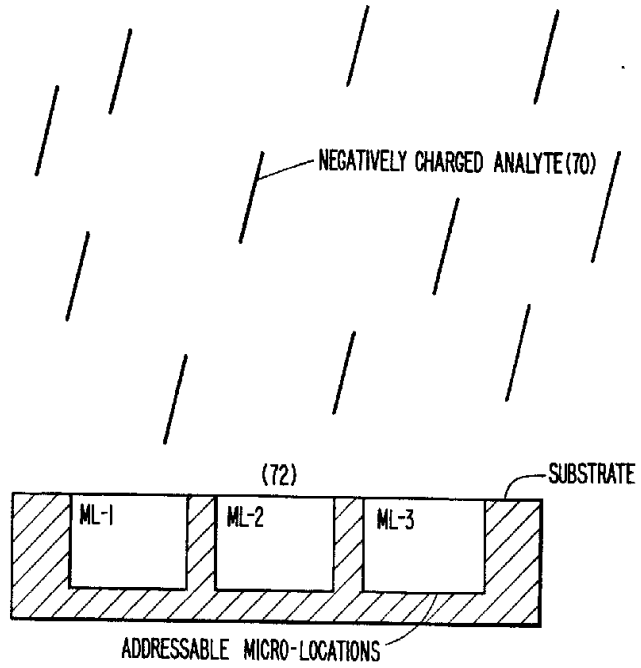

FIG. 7a.

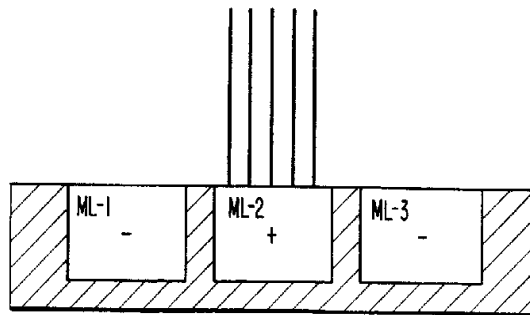

FIG. 7b.

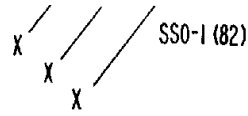

FIG. 8a.

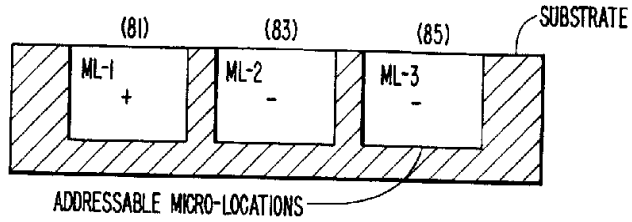

FIG. 8b.

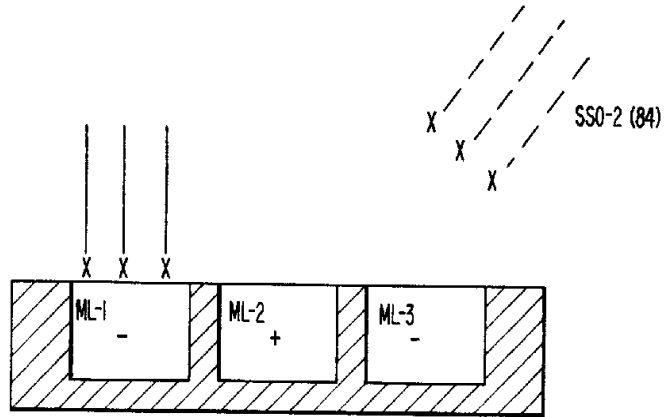

FIG. 8c.

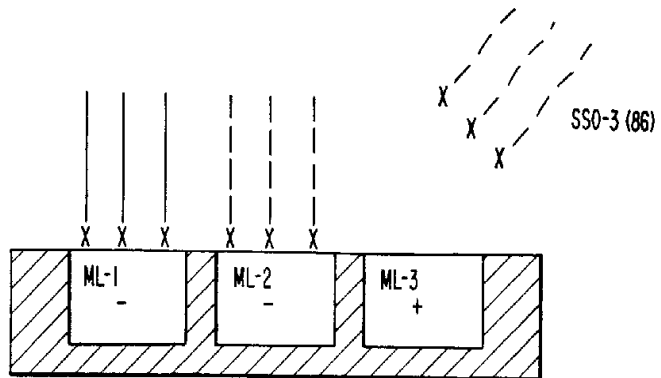
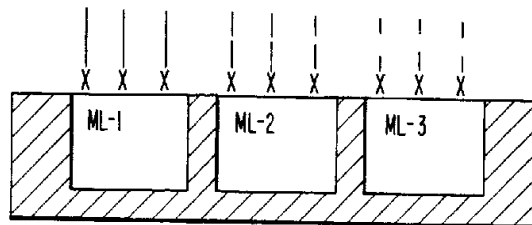

FIG. 8d.



8 / 20
(90)

FIG. 9a.

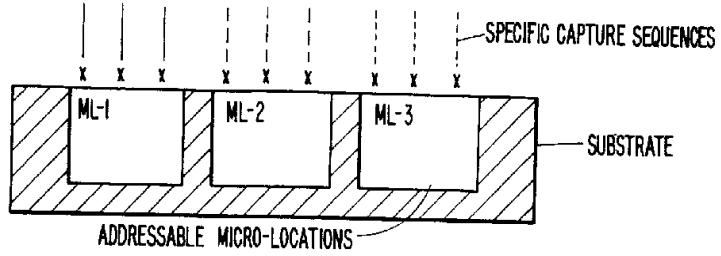

FIG. 9b.

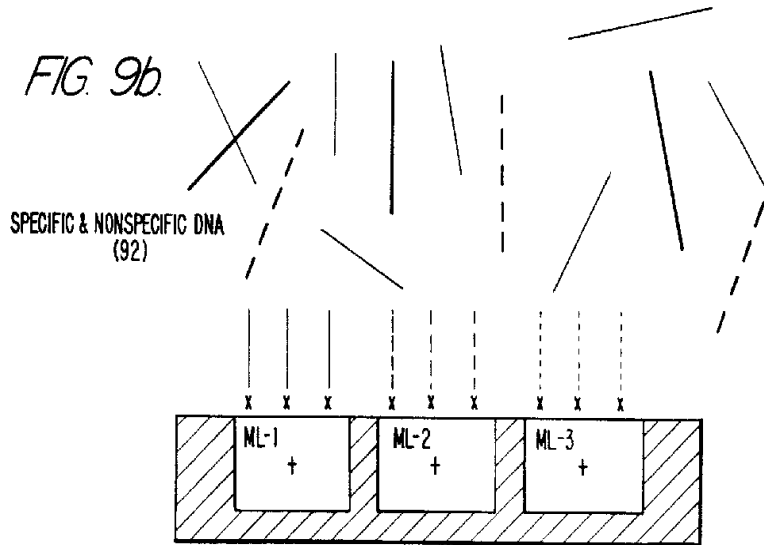
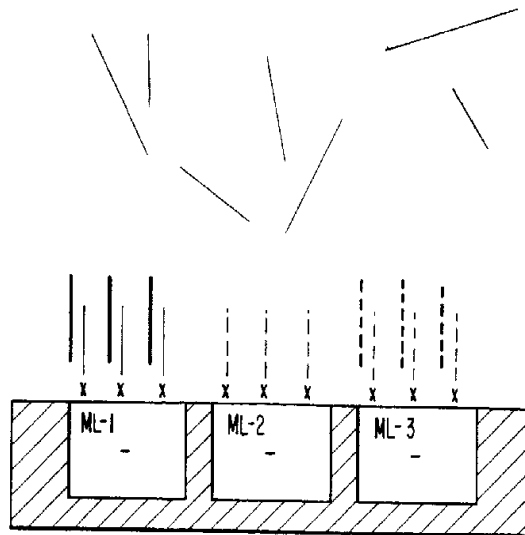
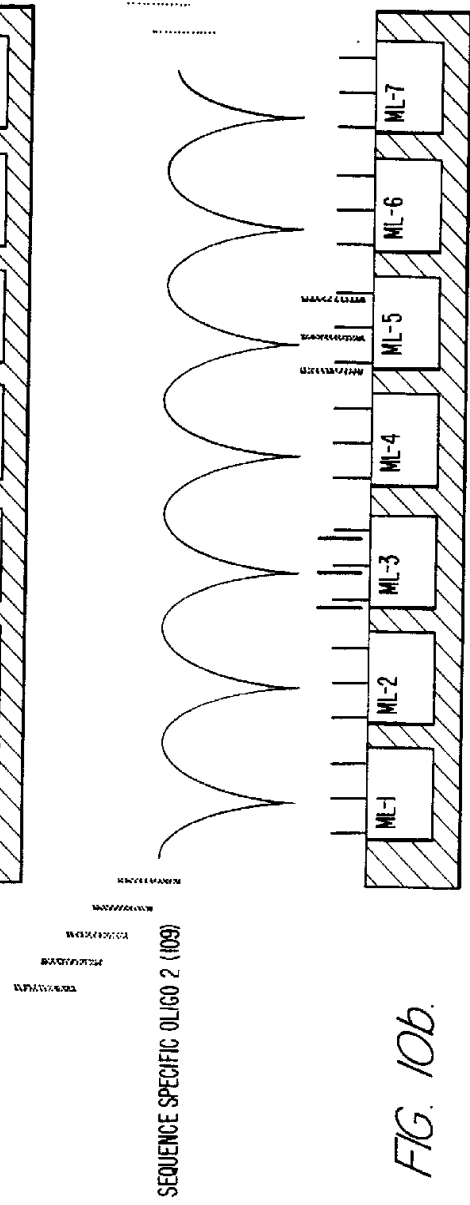
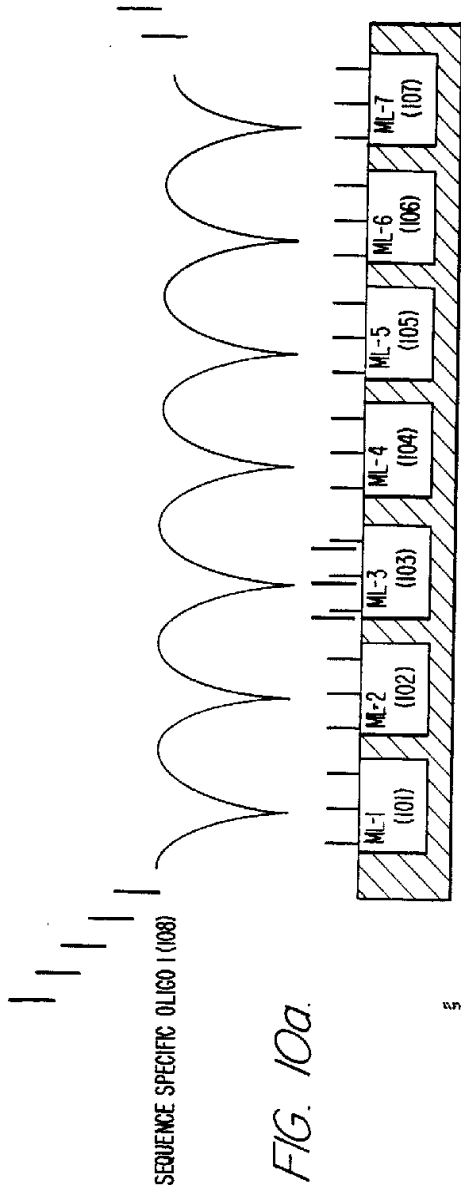

FIG. 9c.





10/20

FIG. 11a.

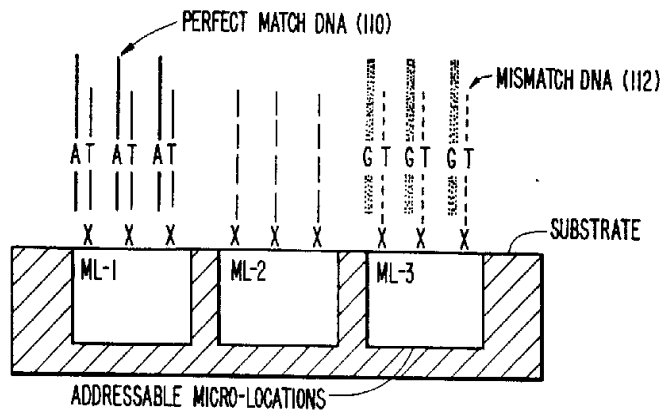

FIG. 11b.

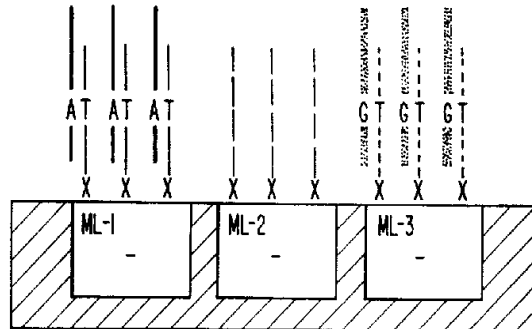

FIG. 11c.

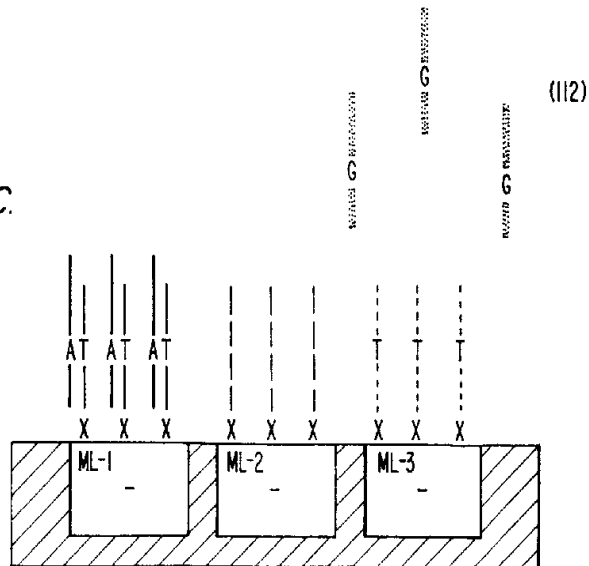

FIG. 12a.

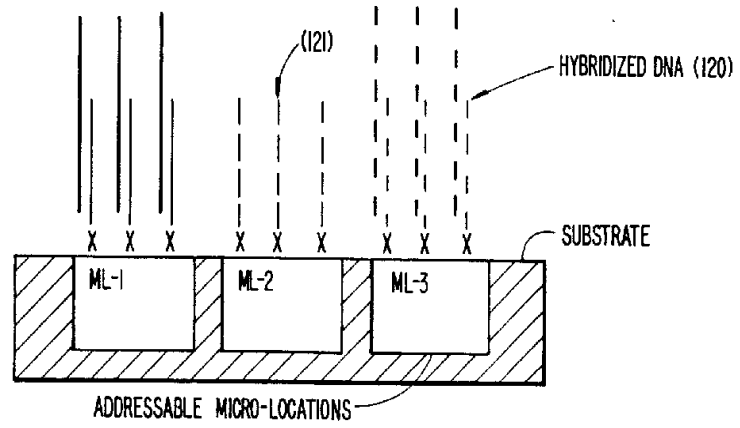

FIG. 12b.

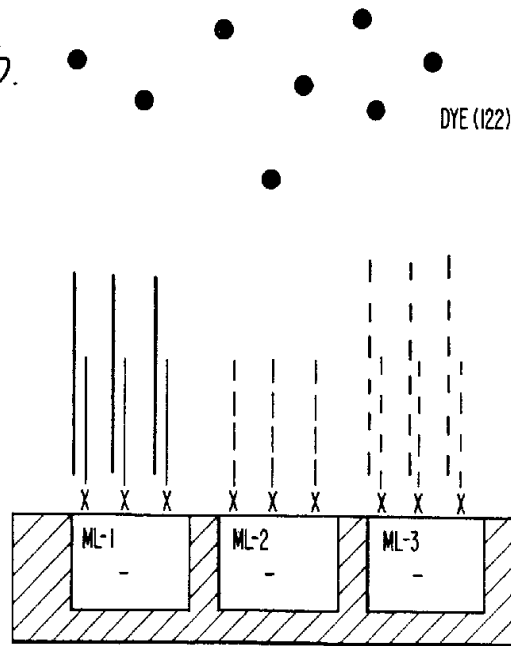

FIG. 12c.

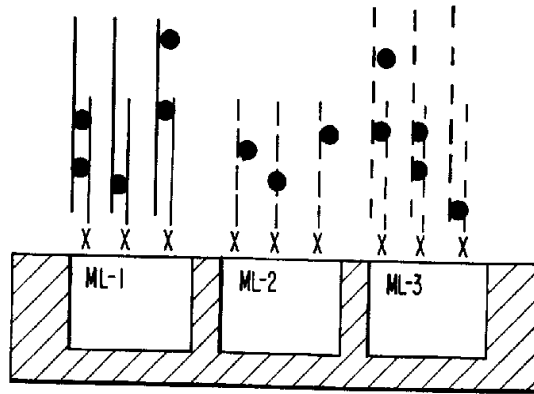
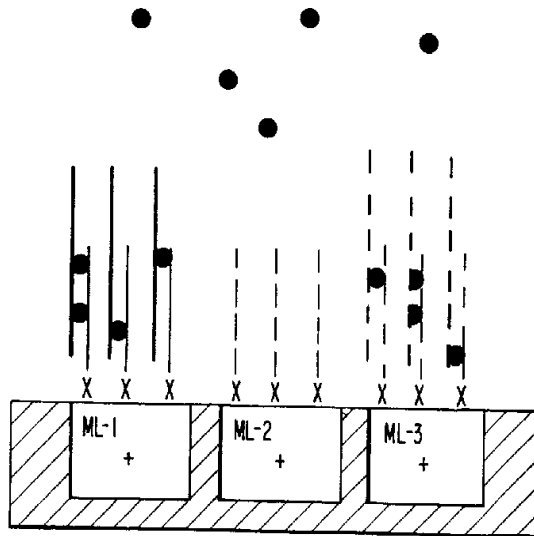

FIG. 12d.



13/20

FIG. 13a.

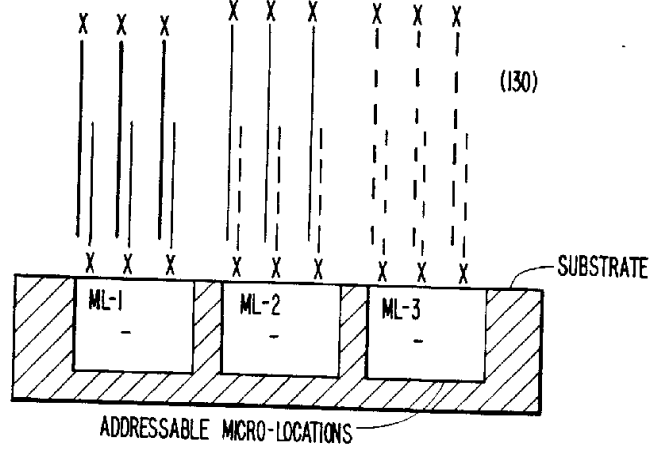

FIG. 13b.

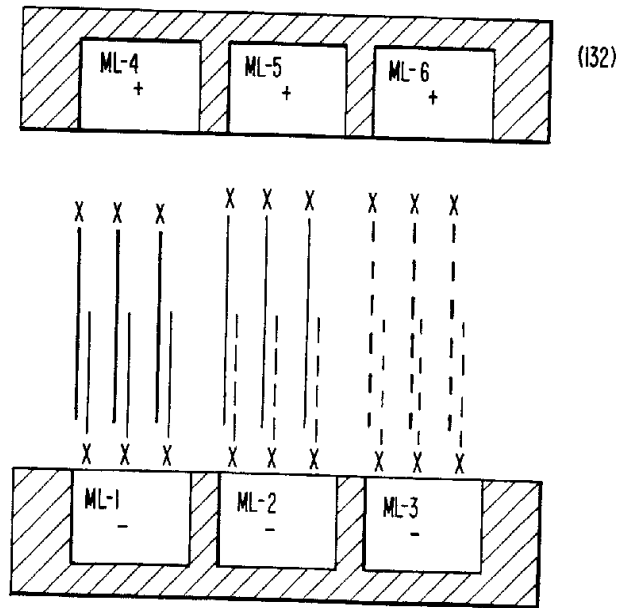

FIG. 13c.

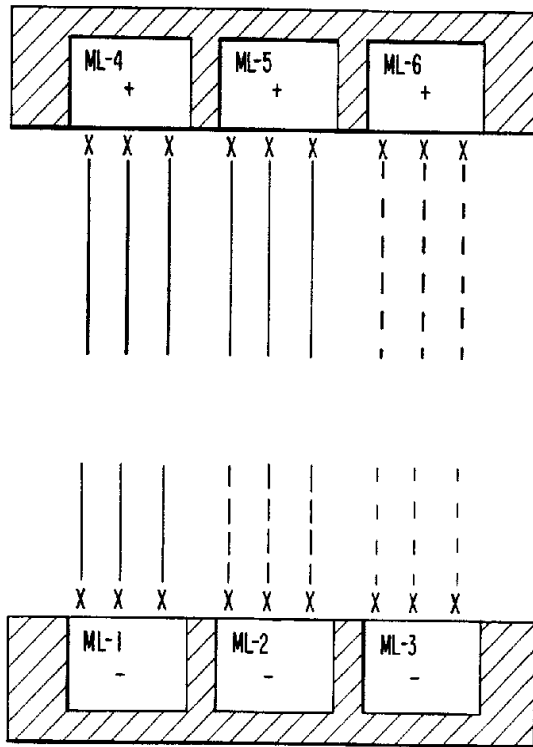

FIG. 14a.

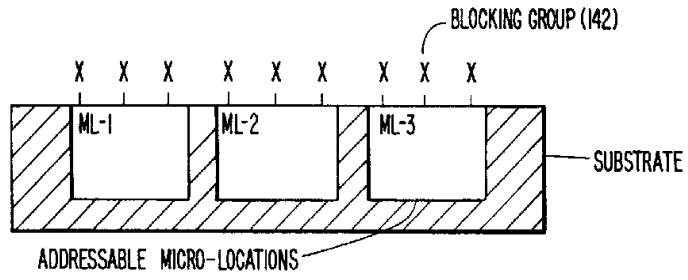

FIG. 14b.

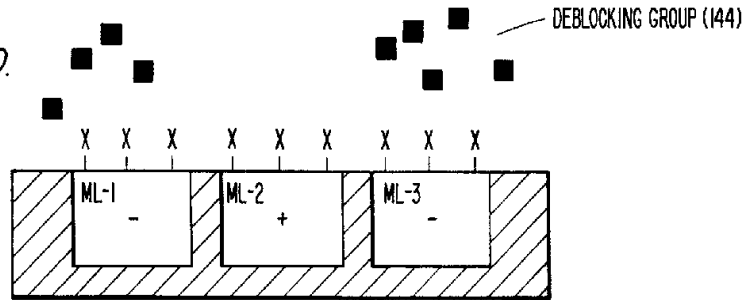
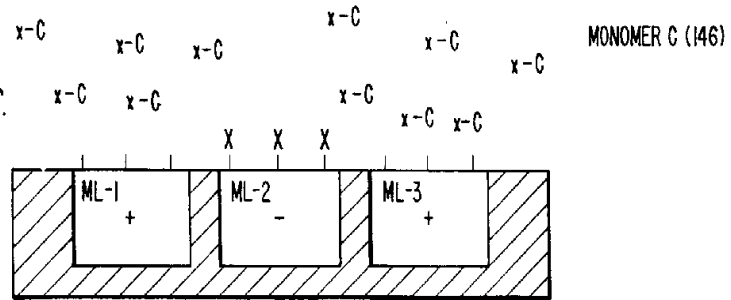

FIG. 14c.



16/20

FIG. 14d.

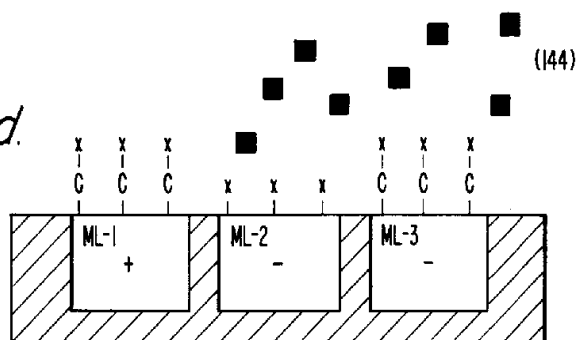

FIG. 14e.

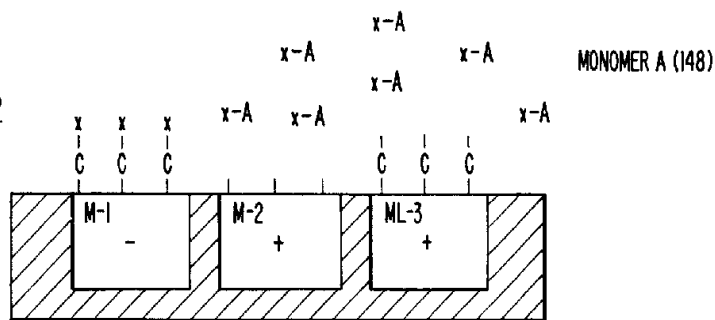
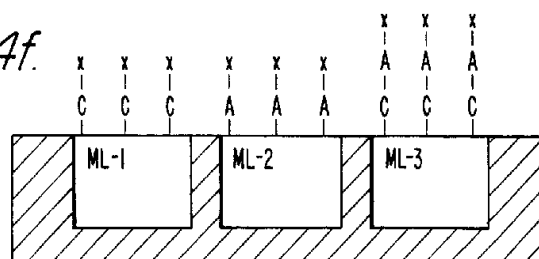

FIG. 14f.



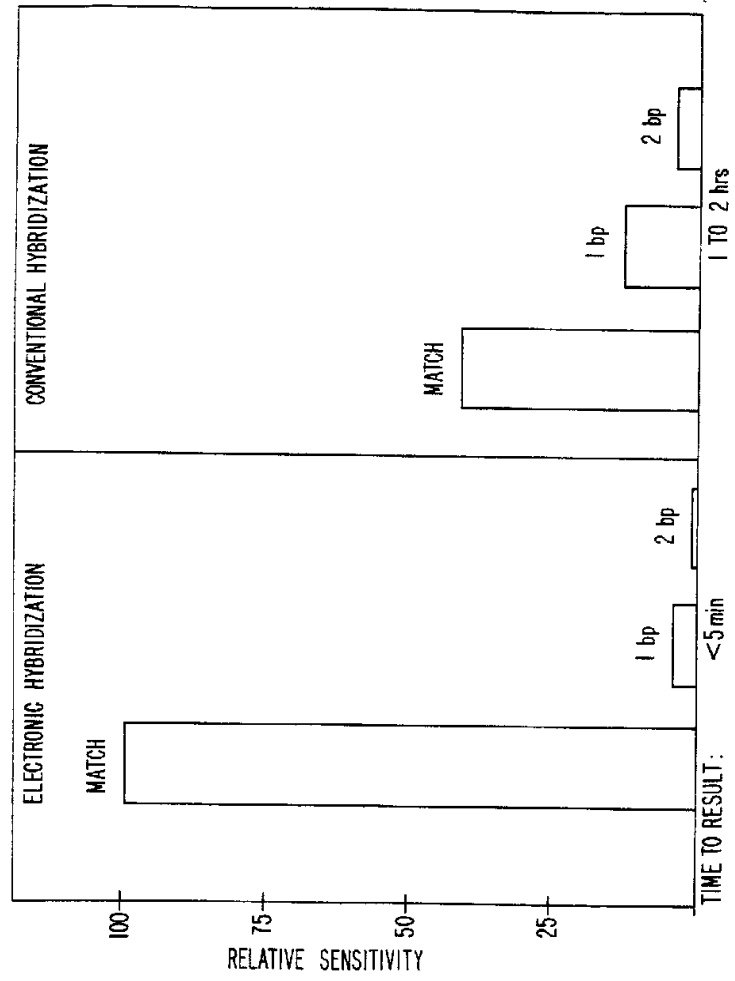

FIG. 15.

FIG. 16

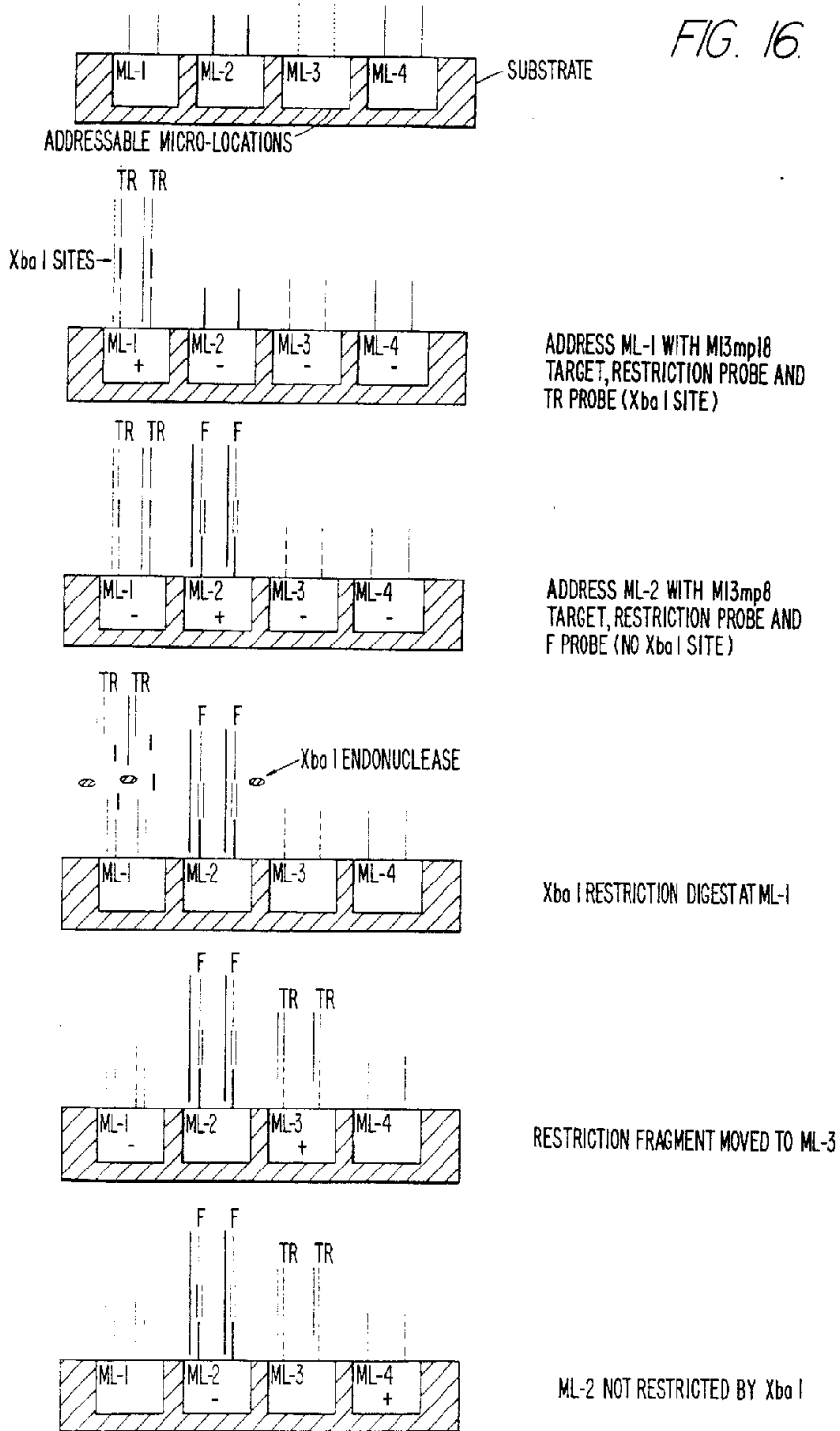
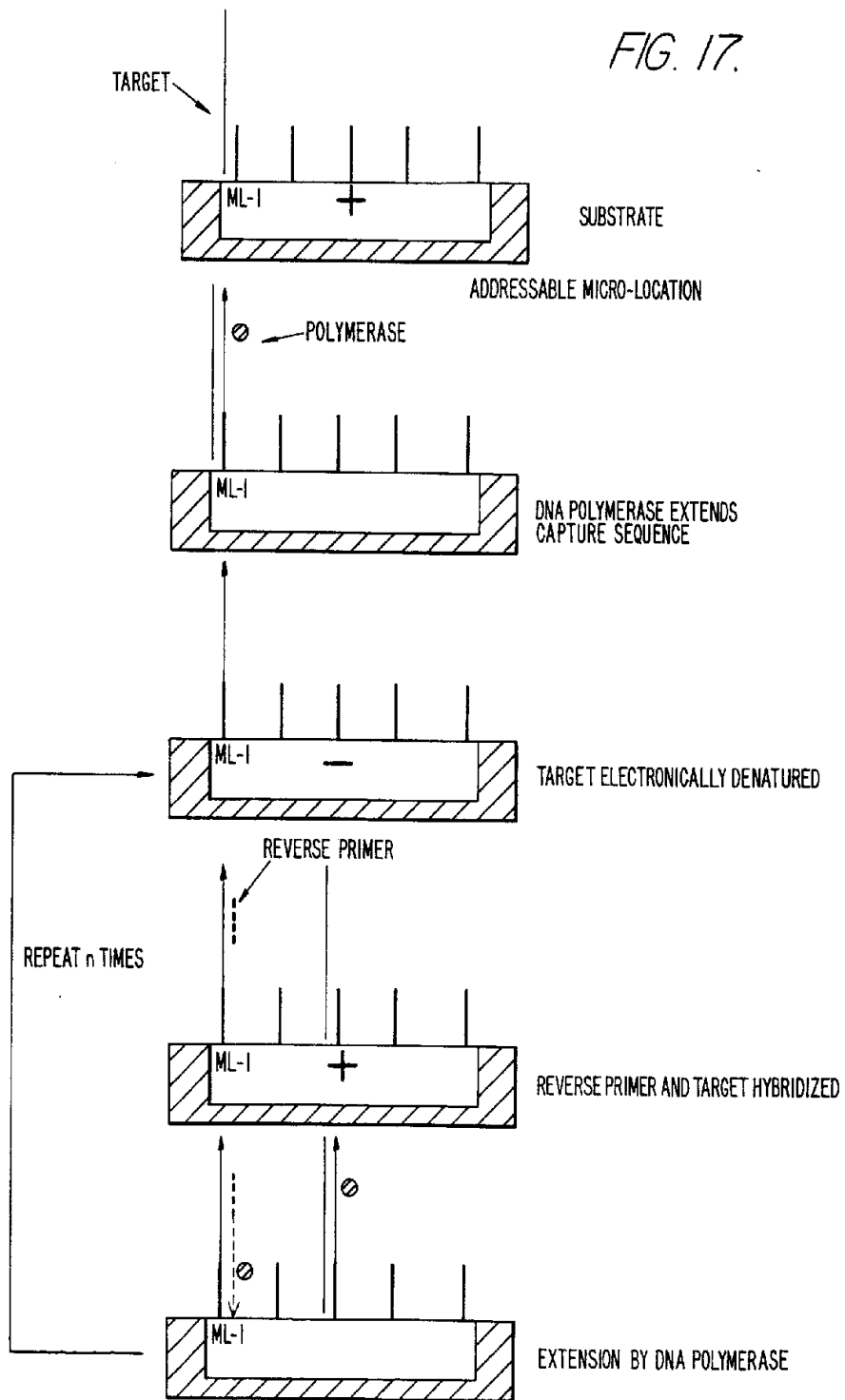

FIG. 17.



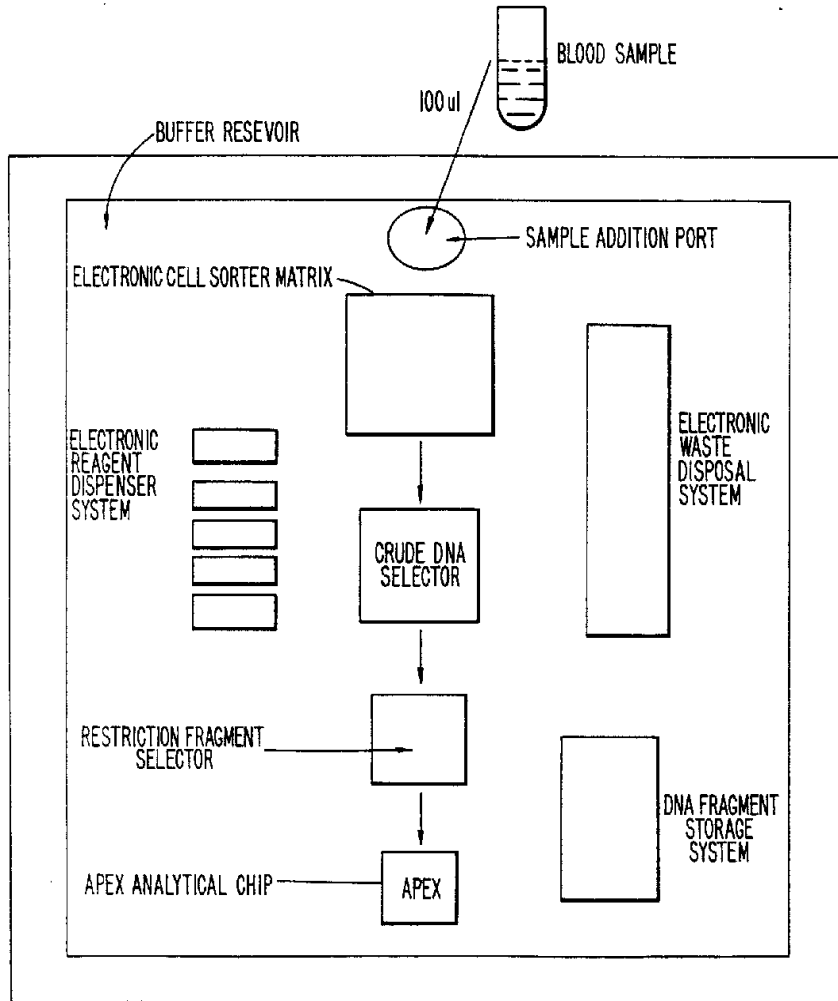

FIG. 18.