

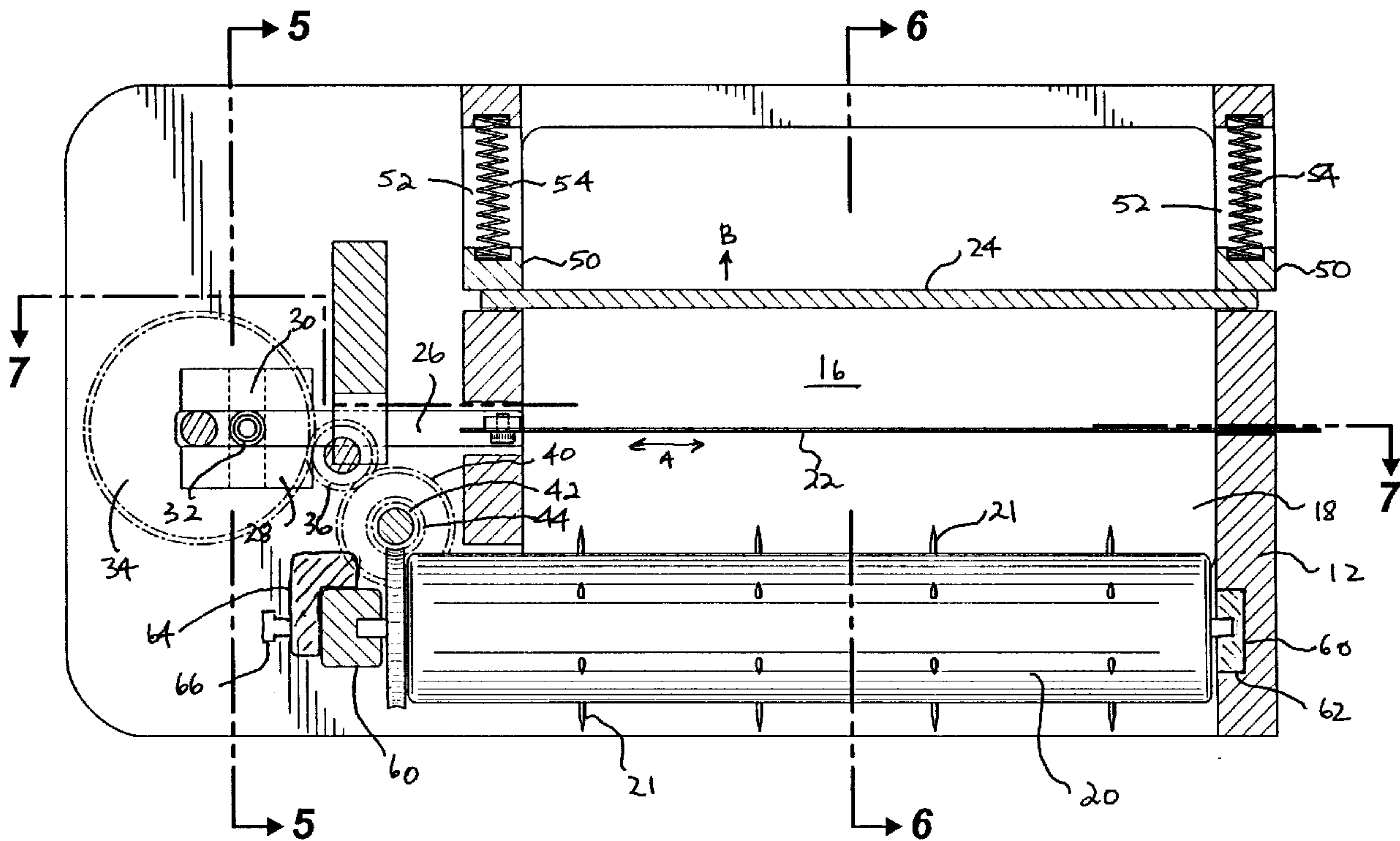

(22) Date de dépôt/Filing Date: 2001/02/16  
 (41) Mise à la disp. pub./Open to Public Insp.: 2001/08/24  
 (45) Date de délivrance/Issue Date: 2006/07/11  
 (30) Priorité/Priority: 2000/02/24 (US09/512,298)

(51) Cl.Int./Int.Cl. *B26D 1/14* (2006.01),  
*B26D 7/06* (2006.01), *B26D 3/30* (2006.01)  
 (72) Inventeur/Inventor:  
 VERKLAN, NICHOLAS, CA  
 (73) Propriétaire/Owner:  
 VERKLAN, NICHOLAS, CA  
 (74) Agent: BENNETT JONES LLP

(54) Titre : TRANCHEUR D'ALIMENTS  
 (54) Title: FOOD SLICING APPARATUS



(57) Abrégé/Abstract:

A bagel or bun slicing apparatus includes a frame mounted to a vertically adjustable stand and base. The frame defines a vertical channel which houses a reciprocating blade and rollers for transporting the bagel or bun through the channel and across the blade. The rollers are rotated by an electric motor which also reciprocates the blade. The rollers and/or a guide plate may be laterally adjustable to allow for bagels or buns of varying widths.

**ABSTRACT**

5           A bagel or bun slicing apparatus includes a frame mounted to a vertically adjustable stand and base. The frame defines a vertical channel which houses a reciprocating blade and rollers for transporting the bagel or bun through the channel and across the blade. The rollers are rotated by an electric motor which also reciprocates the blade. The rollers and/or a guide plate may be laterally adjustable to allow for bagels or buns of varying widths.

10

**FOOD SLICING APPARATUS**

5

**FIELD OF THE INVENTION**

The present invention relates to an apparatus for slicing foods and, in particular, to a bagel or  
10 bun slicing apparatus.

**BACKGROUND OF THE INVENTION**

Bagels are a popular food product, as are buns and the like. Almost invariably, a bagel or a  
15 bun is served sliced into two disk-shaped halves. This is not an easy manual operation and uniform  
cuts while avoiding cutting one's hand may be difficult to achieve. Simple manual bagel slicers exist  
which involve a guillotine action or a knife guide coupled with a bagel holder. However, these  
devices are not entirely satisfactory from a safety and ease-of-use point of view.

20 An automatic bagel slicer is disclosed in U.S. Patent No. 5,690,013 which includes a bagel  
holding mechanism and a knife blade which is both reciprocated and moved vertically to slice the  
bagel. Separate motor mechanisms are used to perform these two functions. As a result of having  
separate motors acting on the knife blade in different ways, the mechanisms are quite complex and  
costly to manufacture.

25

Therefore, there is a need in the art for an automated food slicer, and a slicer for bagels or  
buns in particular, which mitigates the difficulties of the prior art.

**SUMMARY OF THE INVENTION**

The present invention is directed to a food slicing apparatus which is particularly adapted for  
 5 slicing bagels, buns and other breads. In one aspect of the invention, the apparatus comprises:

- (a) a frame forming a channel through which food may pass;
- (b) a cutting blade positioned within and across the channel;
- 10 (c) a roller rotatably mounted to the frame for gripping and moving food through the channel and through the cutting blade;
- (d) a motor for rotating the roller; and
- 15 (e) power transmission means connecting the motor to the roller.

In one embodiment, the roller is mounted to the frame such that the roller may move laterally so as to widen or narrow the width of the channel. Preferably, the apparatus may further comprise biasing  
 20 means for urging the roller to a position which narrows the width of the channel. There may be provided a guide plate disposed in the channel opposite the roller such that the food passes between the roller and the guide plate wherein guide plate may be mounted to the frame in a manner permitting lateral movement of the guide plate so as to widen or narrow the space between the roller and the guide plate. Preferably, the apparatus may further comprise biasing means for urging the  
 25 guide plate to a position which narrows the width of the channel.

In one embodiment, the roller comprises a surficial gripping element which grips the food. The surficial gripping element may comprise a plurality of spikes.

In one embodiment, the power transmission means comprises a flexible drive wire which is driven by the motor and which rotates the roller. In an alternative embodiment, the power transmission means may comprise an elongate worm gear which drives a ring gear attached to the roller.

5

In one embodiment, the apparatus comprises two rollers which are both rotated in the same direction by the motor and the power transmission means.

In one embodiment, the cutting blade is mounted to the frame such that the blade may move across the channel in a reciprocating manner. This embodiment may further comprise a motor and power transmission means for reciprocating the blade. The motor may be the same motor which drives the rollers. The reciprocating power transmission means may comprise a drive body attached to the blade and defining a transverse slot which mates with a pin attached to a pinion gear driven by the motor, such that rotation of the pin causes reciprocating movement of the drive body and blade.

15

In one embodiment, the frame is mounted to a stand and a base wherein the stand permits adjustment of the vertical height of the frame above the base.

## 20 **BRIEF DESCRIPTION OF THE DRAWINGS**

Embodiments of the invention will now be described by way of an exemplary embodiment with reference to the accompanying simplified, diagrammatic, not-to-scale drawings. In the drawings:

25

Figure 1 is a perspective view of one embodiment of the invention. Figure 1A is an end view showing the adjustable stand of one embodiment.

Figure 2 is a top plan view of the embodiment shown in Figure 1 with the housing removed.

5 Figures 3 and 4 are the same view shown in Figure 2 showing movement of the blade and the blade power transmission means.

Figure 5 is a cross-sectional view along line 5-5 in Figure 2 showing the motor and power transmission means in one embodiment.

10 Figure 6 is a cross-sectional view along line 6-6 in Figure 2.

Figure 7 is a vertical cross-sectional view along line 7-7 in Figure 2.

15 Figure 8 is a top plan view of an embodiment showing an alternative power transmission means for rotating the rollers and reciprocating the blade.

Figure 9 is a vertical cross-sectional view along line 9-9 in Figure 8.

### **DETAILED DESCRIPTION OF THE INVENTION**

20 The apparatus (A) according to the Figures comprises a food slicing apparatus which is particularly adapted to slicing bagels, buns and other bread products. The foregoing description shall refer to the object being sliced as a bagel. However, a person skilled in the art will be able to modify the disclosed embodiments to the extent necessary to adapt the apparatus to slicing other foods  
25 without departing from the scope of the invention. It is intended that such modifications be included within the scope of the claims herein.

In one embodiment, the apparatus (A) comprises a stand (5), a frame (12) and a housing (14) which are typical of small kitchen appliances. The stand (5) includes a base (6) and a upright

support (7). The components of the apparatus (A) are mounted to or supported by the frame (12) while the housing (14) serves as a decorative and protective cover. The specific configuration of the frame (12) is not an essential element of the invention. The housing (14) is not an essential element of the invention. The frame defines a channel (16) having a top opening (18) which is illustrated in  
5 Figure 1 and in top plan view in Figure 2. Although the embodiments illustrated herein have the channel (16) oriented vertically, the orientation of the channel is not an essential element.

In one embodiment, the upright support (7) may be adjustable for height as is shown in Figure 1A. The upright support (7) may include separate pieces (7a, 7b) which slidingly or  
10 telescopingly engage each other to provide such adjustability. A locking pin (8) and bar (9) may be provided to secure the support (7) in its extended position.

Referring to Figure 2, rollers (20) are rotatably mounted to the frame (12). In one embodiment, the rollers (20) have a plurality of small spikes (21) which grip the bagel and pass it  
15 through the channel (16) when the rollers (20) are rotated. Disposed within and across the channel (16) is a cutting blade (22) which is fixed in the vertical plane but, in one embodiment, may move laterally across the channel (16) in a reciprocating manner, as shown by arrow A in Figure 2. As shown in Figures 2 and 7, the blade (22) is mounted to a link arm (26) which is attached to a block (28). The block (28) has a transverse slot (30) which engages a pin (32) mounted eccentrically on a  
20 wheel (34). The wheel (34) is rotated by a drive gear (36). As may be seen in Figures 3 and 4, rotation of the wheel (34) causes the pin (32) to orbit the centre of the wheel (34). As a result, lateral reciprocating motion is imparted to the blade (22) by means of the block (28) and the link arm (26). The specific mechanism to reciprocate the blade (22) is not intended to be limiting of the invention, except where specifically claimed as such. One skilled in the art may conceive of alternative  
25 mechanisms to reciprocate the blade.

The spikes (21) are one example of a surficial gripping element to grip the bagel and pass it through the channel. One skilled in the art may conceive of many alternatives to accomplish the same task. For example, the roller may have a rubber textured surface such as a plurality of ribs or

nubs where the rubber provides frictional engagement of the bagel, aided by the surface texture. Alternatively, the rollers (20) may drive a rubber belt (not shown).

5 The drive gear (36) is driven by an electric motor (38) which may be a conventional DC or AC electric motor used in small appliances or tools. The drive gear (36) rotates the wheel (34) to reciprocate the blade (22) as described above. In one embodiment, the drive gear (36) also rotates the rollers (20) by means of an idler gear (40) which is attached to a vertically disposed shaft (42). The shaft (42) has worm gear sections (44) which engages roller gears (46) to rotate both rollers (20).

10 Referring to Figure 6, a guide plate (24) is provided opposite the rollers (20) which provides a vertical guide for the bagel as it passes through the channel (16). The guide plate (24) has an outwardly curved top portion (48) to facilitate entry of the bagel into the channel (16) and lateral tabs (49) which slide within openings (52) in the frame (12). Guide members (50) disposed in the openings (52) slidably engage the upper and lower edges of the openings and bear against the guide  
15 plate tabs (49). The guide plate (24) may be inserted into the frame through slots (53). As may be seen in Figure 2, the guide plate (24) may move in the direction of arrow "B" to widen the channel (16) in order to accommodate bagels of varying widths. Biasing means in the form of springs (54) urge the guide plate (24) towards the rollers (20). Preferably, the distance between the guide plate in its extended position and the rollers (20) is slightly smaller than a small bagel. In that case, all  
20 bagels will displace the guide plate (24) to some degree and will therefore be urged against the rollers (20) to ensure that the rollers (20) are effective in transporting the bagel through the channel (16).

In one embodiment, the rollers (20) are mounted in a subframe (60) which engages a slot (62)  
25 in the frame (12) at one end and a support post (64) at the other end. The subframe (60) may be secured in position by a pin (66) which passes through the support post (64) and engages the subframe. As is apparent from the Figures, once the pin (64) is disengaged, the subframe (60) may be removed from the frame. In one embodiment, the idler gear (40) and shaft (42) are also mounted to the subframe (60).

An alternative embodiment of the invention is illustrated in Figures 8 and 9. In this embodiment, the width of the channel (116) is varied by lateral movement of the rollers. As shown in Figure 8, the rollers (120) are mounted to a subframe (150) which is mounted on support members (151) matched to channels (152) provided in the frame (112). The subframe is biased towards the cutting blade (122) by means of springs (154) disposed within the channels (152).

The blade (122) is reciprocated by means similar to that shown in Figure 2 above. A wheel (134) having an offset pin (132) engages a transverse slot (130) in a block (128). The block is linked to the blade by a link arm (126). The wheel (134) is rotated by a drive gear (136) which is driven by an electric motor (not shown). The drive gear also causes rotation of the rollers (120) by an alternative configuration of gears (136) which drives an upright bevel gear (138) which rotates a flexible shaft (140). The flexible shaft (140) passes through an opening in an upright partition (144) part of the frame (112) and drives a spur gear (142) which rotates a roller gear (144) on the upper roller (120a). The upper roller (120a) then drives the lower roller (120b) by means of an intermediary spur gear (not shown).

The apparatus may include a switch (60) on the exterior of the housing (14) for turning the motor on and off. Alternatively or additionally, the operation of the apparatus may be automated by providing means (not shown) for sensing the entry and exit of a bagel in the channel (16). Such means may include a pressure switch or an optical beam, which are well known in the art. The sensing means may then be operatively connected to a switch for turning the motor on or off.

The embodiment illustrated in Figure 9 does not have the optional extendable stand (7) as is shown in the other Figures.

As will be apparent to those skilled in the art, various modifications, adaptations and variations of the foregoing specific disclosure can be made without departing from the scope of the invention claimed herein.

5

**WHAT IS CLAIMED IS:**

1. A food slicing apparatus comprising:
  - 5 (a) a frame comprising two opposed end plates and a guide plate spanning between the end plates, said frame forming a channel through which food may pass;
  - (b) an elongate cutting blade positioned within and across the channel, parallel to the guide plate;
  - 10 (c) a roller opposite to the guide plate rotatably mounted to the frame for gripping and moving food through the channel and through the cutting blade;
  - (d) a motor for rotating the roller; and
  - 15 (e) power transmission means connecting the motor to the roller.
2. The apparatus of claim 1 wherein the roller is mounted to the frame such that the roller may move laterally so as to widen or narrow the width of the channel.
- 20 3. The apparatus of claim 1 wherein said guide plate is mounted to the frame in a manner permitting lateral movement of the guide plate so as to widen or narrow the space between the roller and the guide plate.
- 25 4. The apparatus of claim 2 further comprising biasing means for urging the roller to a position which narrows the width of the channel.
5. The apparatus of claim 3 further comprising biasing means for urging the guide plate to a position which narrows the width of the channel.

6. The apparatus of claim 1 wherein the roller comprises a surficial gripping element which grips the food.
7. The apparatus of claim 6 wherein the surficial gripping element comprises a plurality of  
5 spikes.
8. The apparatus of claim 1 wherein the power transmission means comprises a flexible drive wire which is driven by the motor and which rotates the roller.
- 10 9. The apparatus of claim 1 wherein the power transmission means comprises an elongate worm gear which drives a ring gear attached to the roller.
10. The apparatus of claim 1 wherein the roller comprises two rollers which are both rotated in the same direction by the motor and the power transmission means.
- 15 11. The apparatus of claim 1 wherein the cutting blade is mounted to the frame such that the blade may move across the channel in a reciprocating manner.
12. The apparatus of claim 11 further comprising a motor and power transmission means for  
20 reciprocating the blade.
13. The apparatus of claim 12 wherein the motor is the same motor which drives the rollers.
14. The apparatus of claim 12 wherein the reciprocating power transmission means comprises a  
25 drive body attached to the blade and defining a transverse slot which mates with a pin attached to a pinion gear driven by the motor, such that rotation of the pin causes reciprocating movement of the drive body and blade.

15. The apparatus of claim 1 wherein the frame is mounted to a base and an upright support member wherein the support member permits adjustment of the vertical height of the frame above the base.

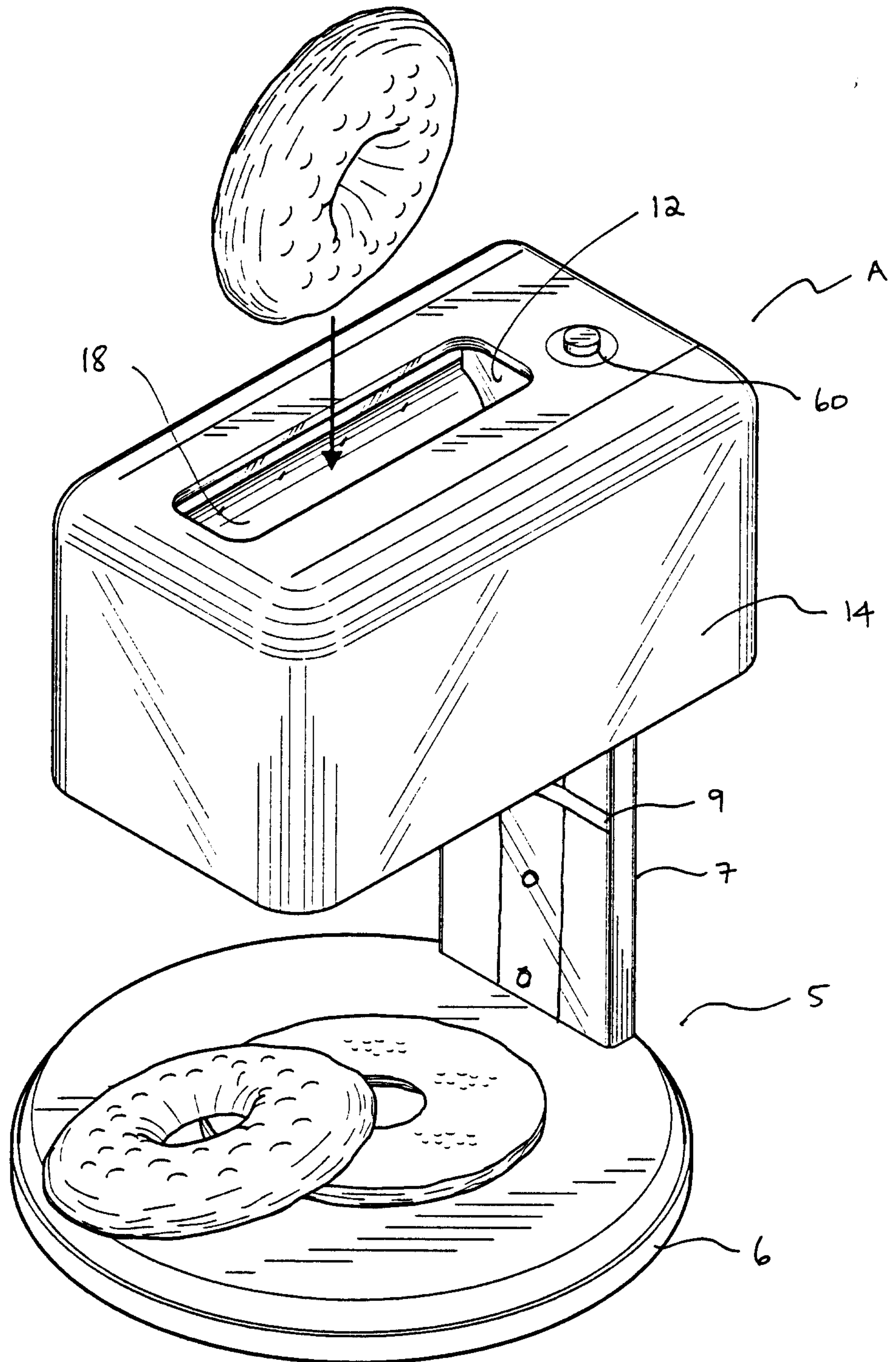

FIG. 1

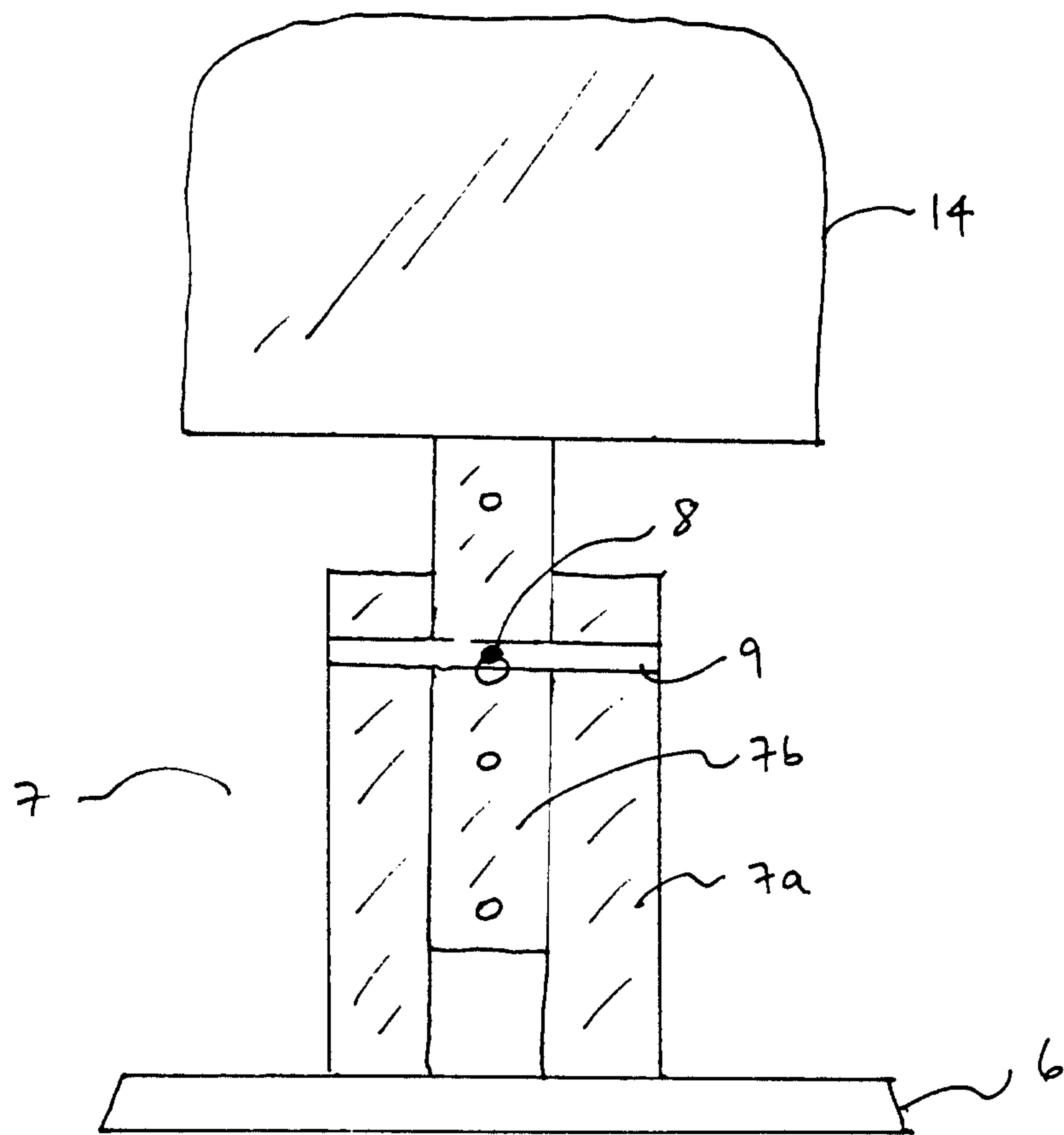

FIG. 1A

FIG. 2

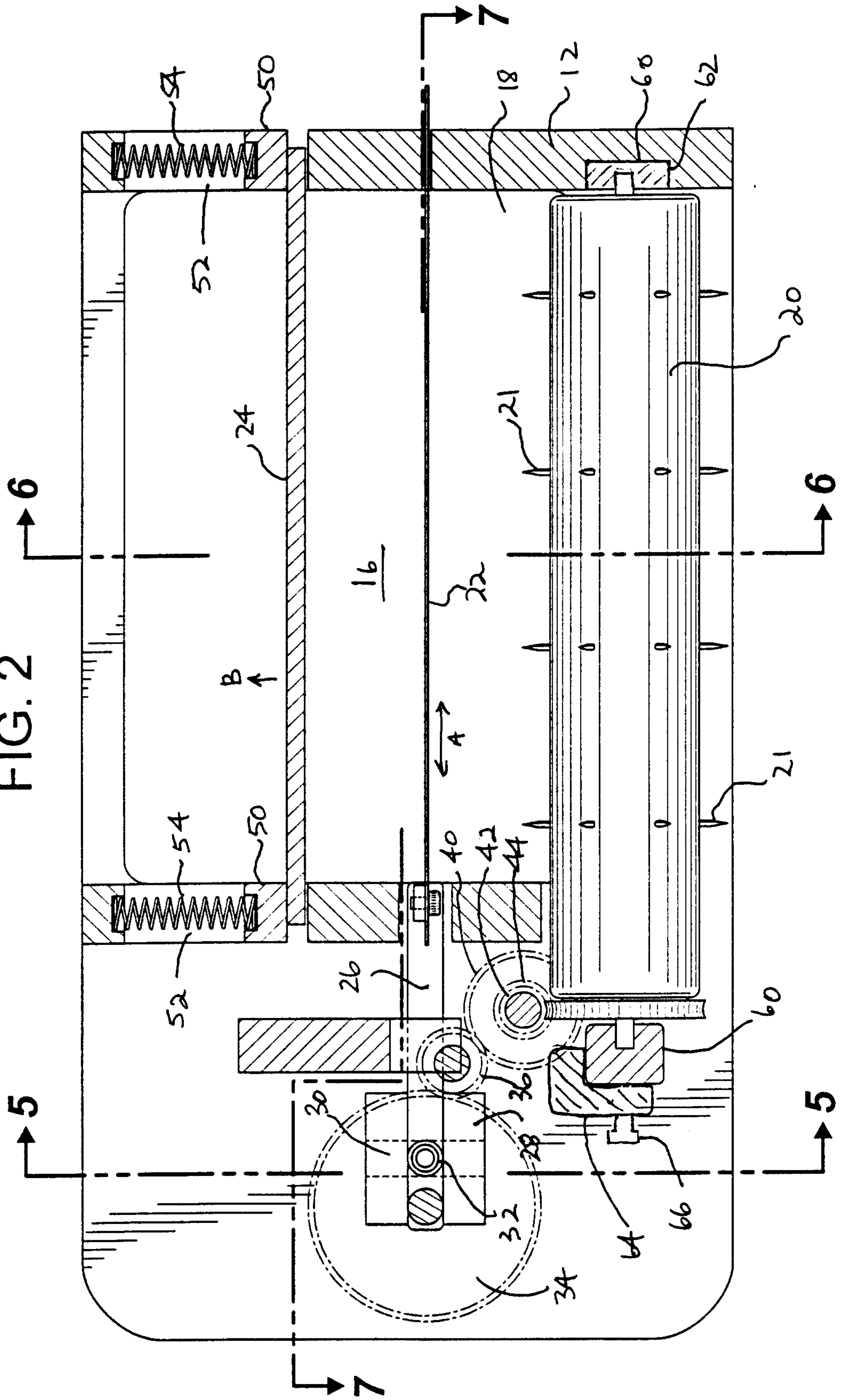
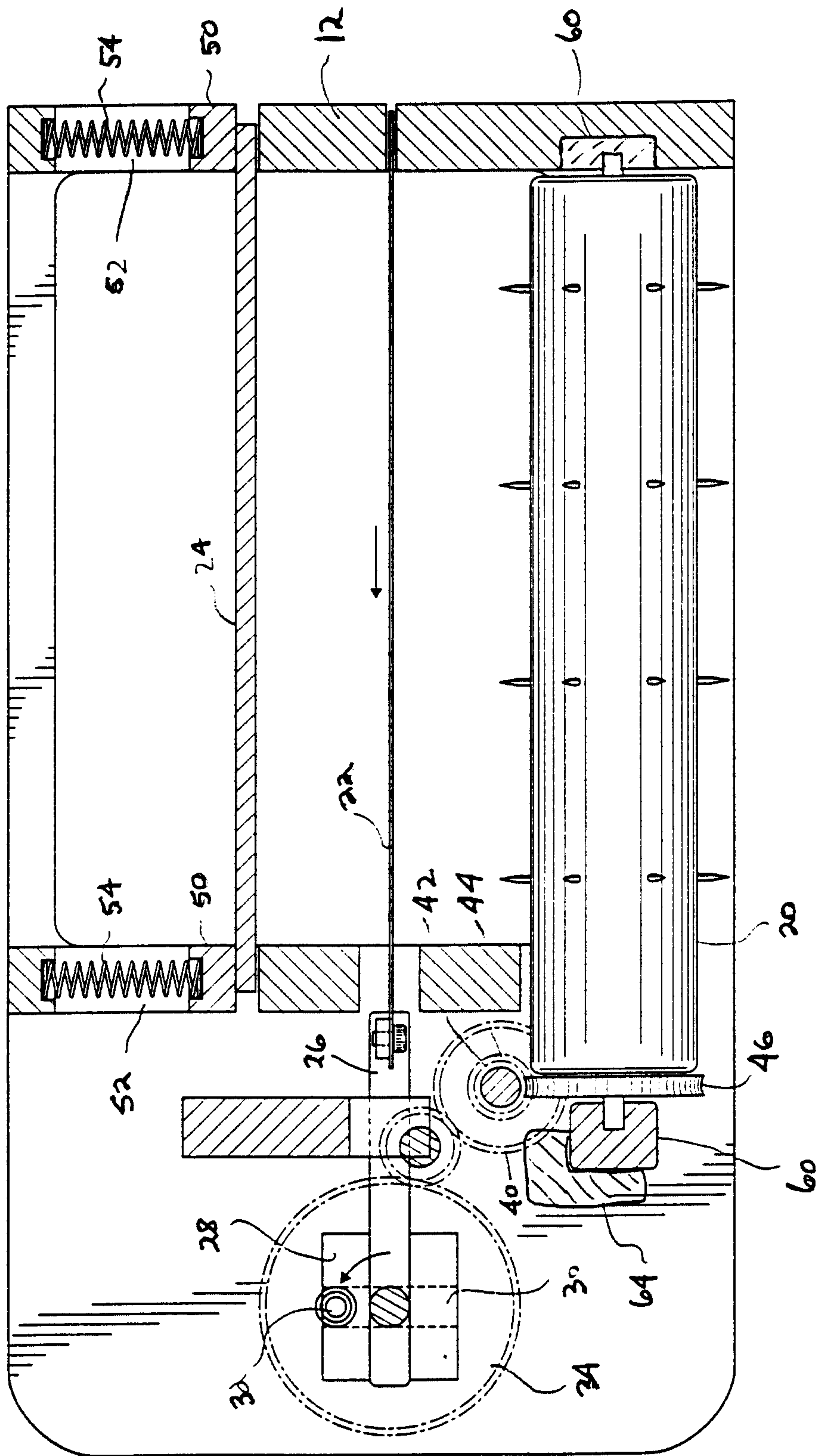

FIG. 3





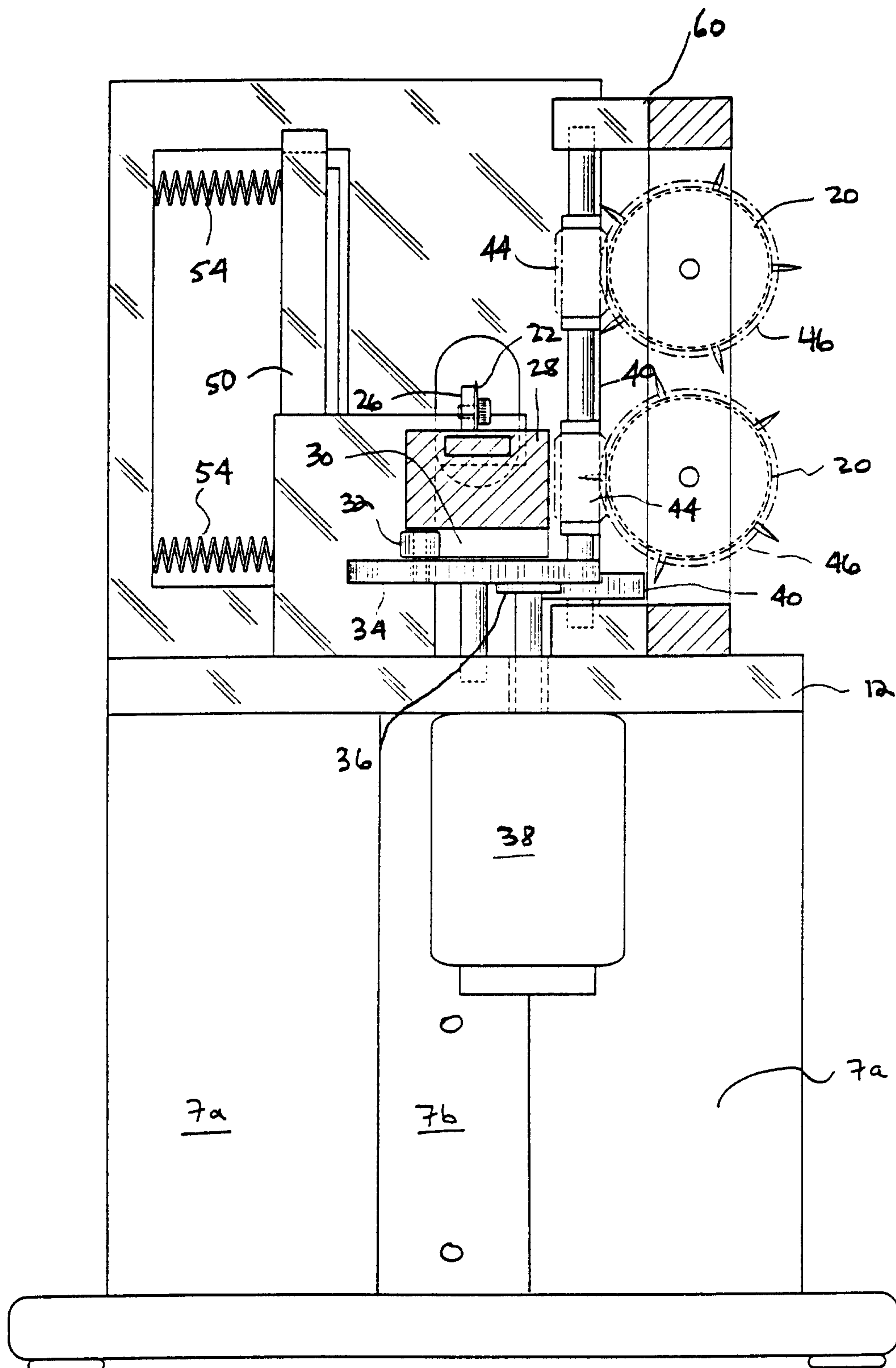
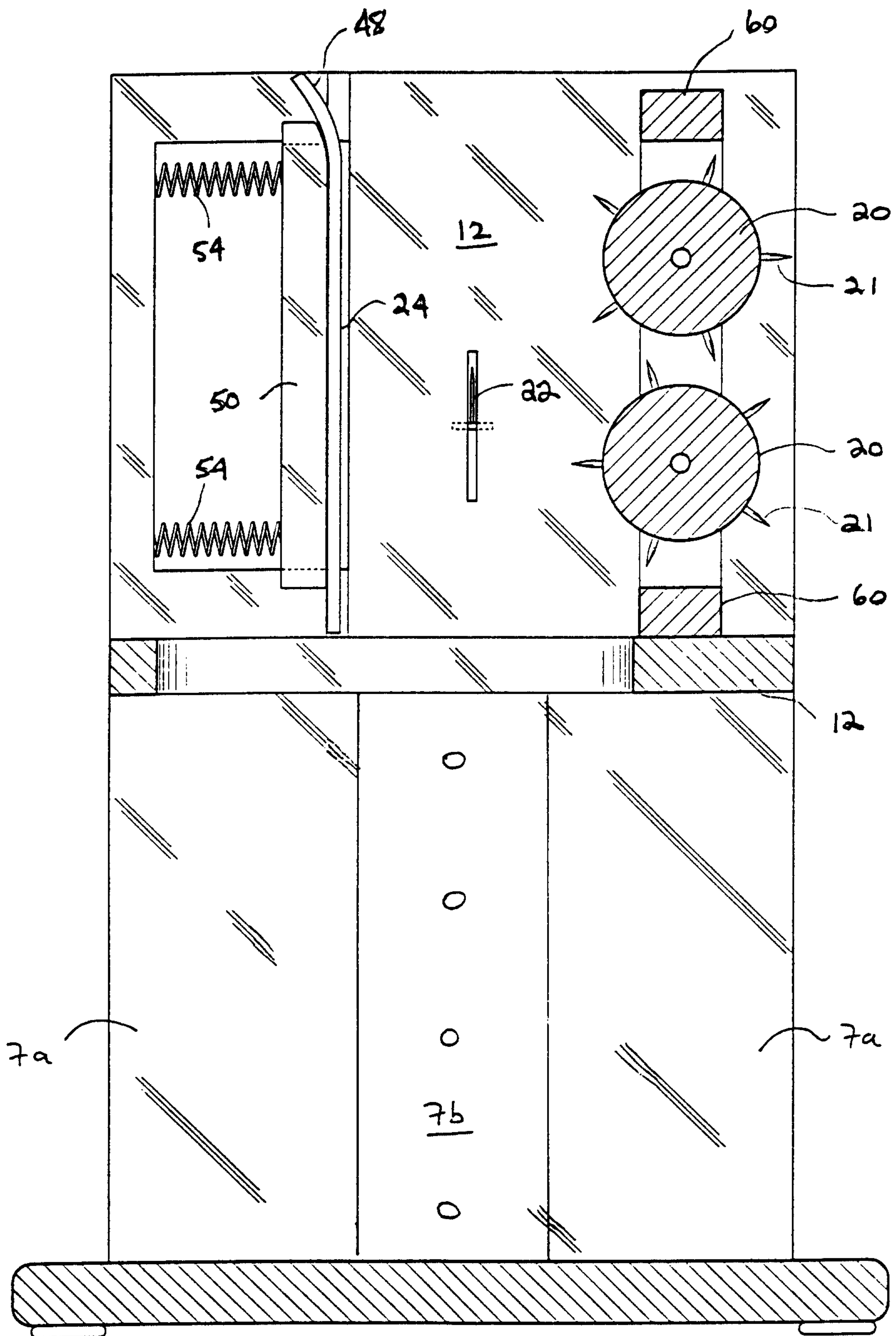

FIG. 5



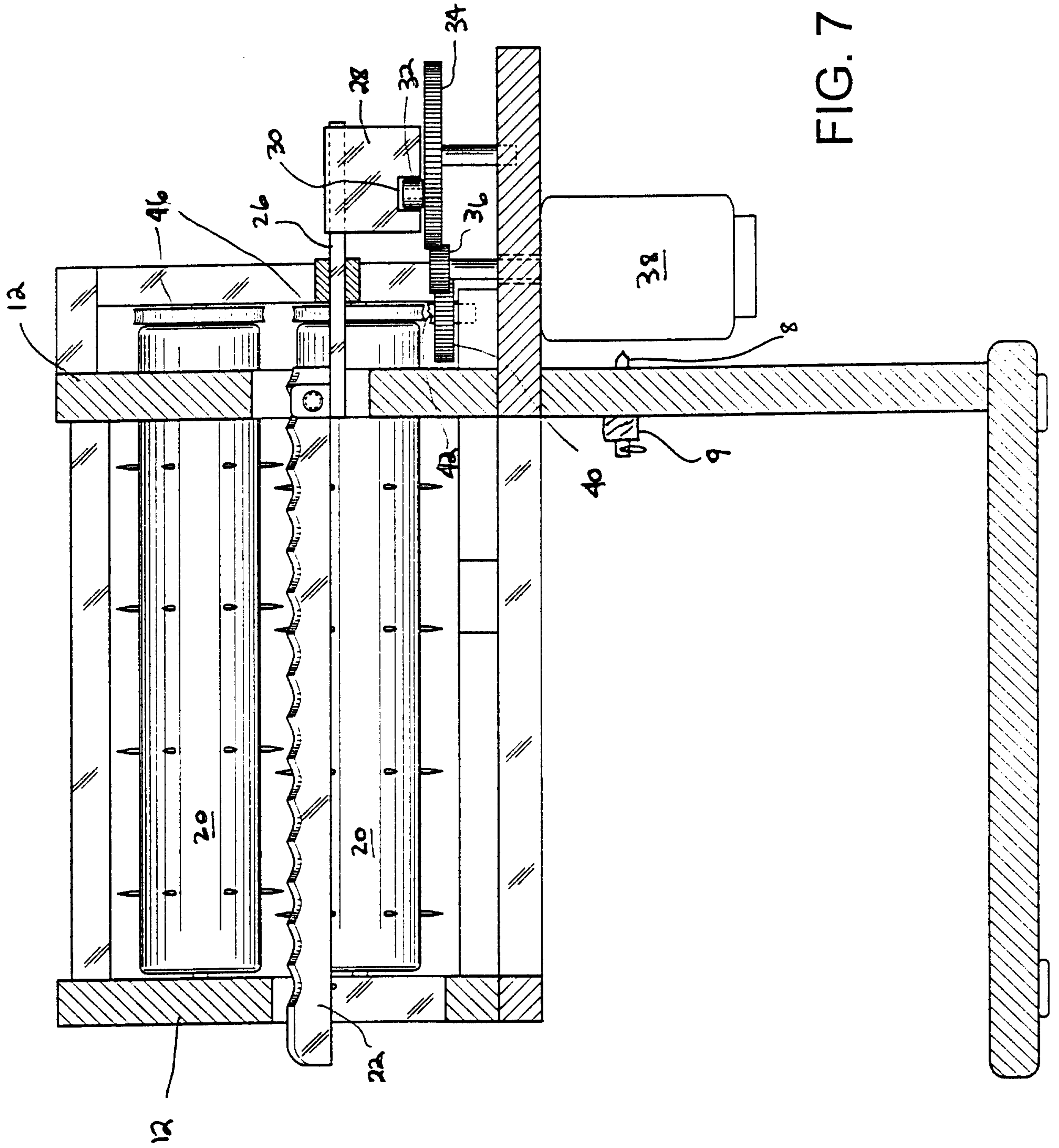
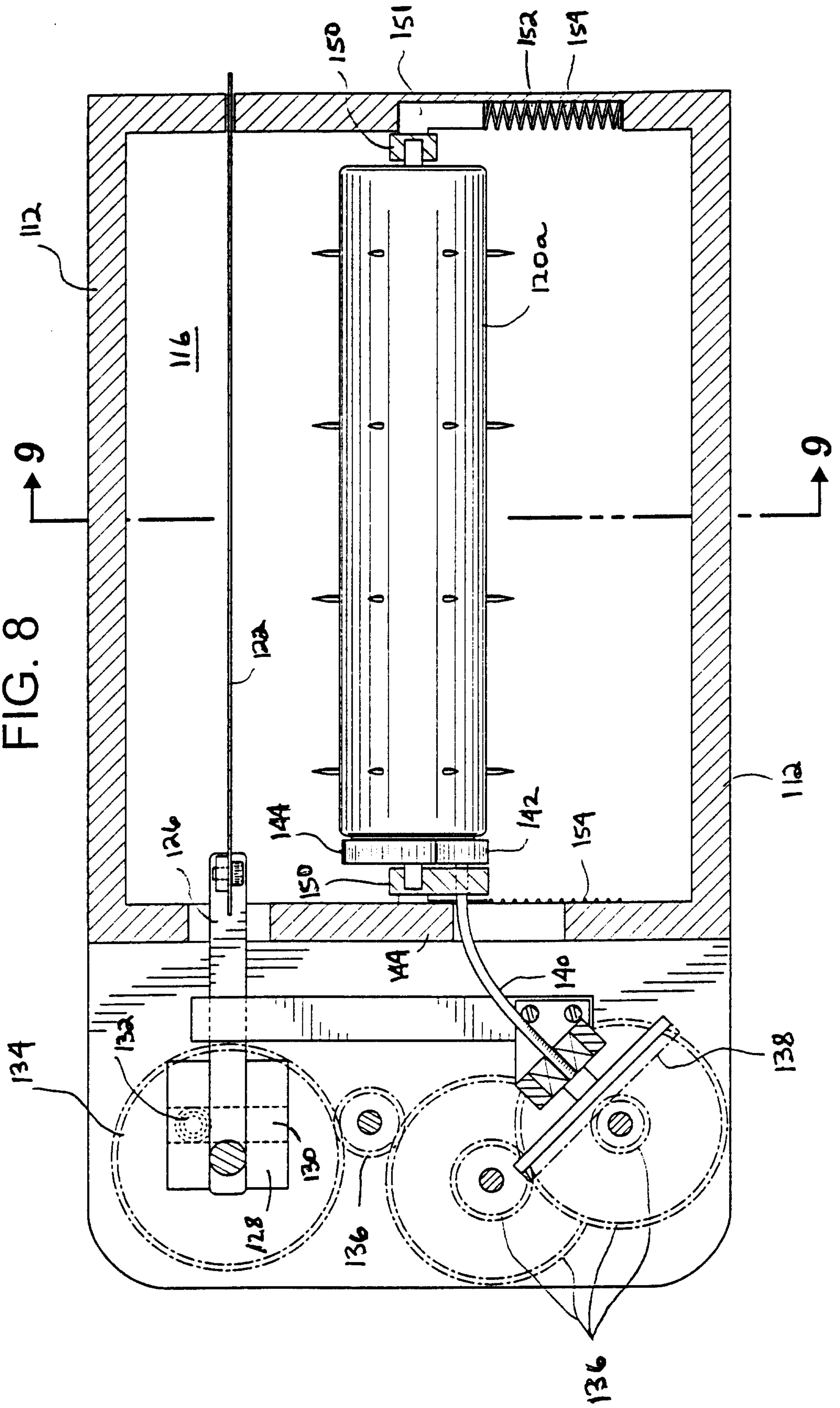

FIG. 8



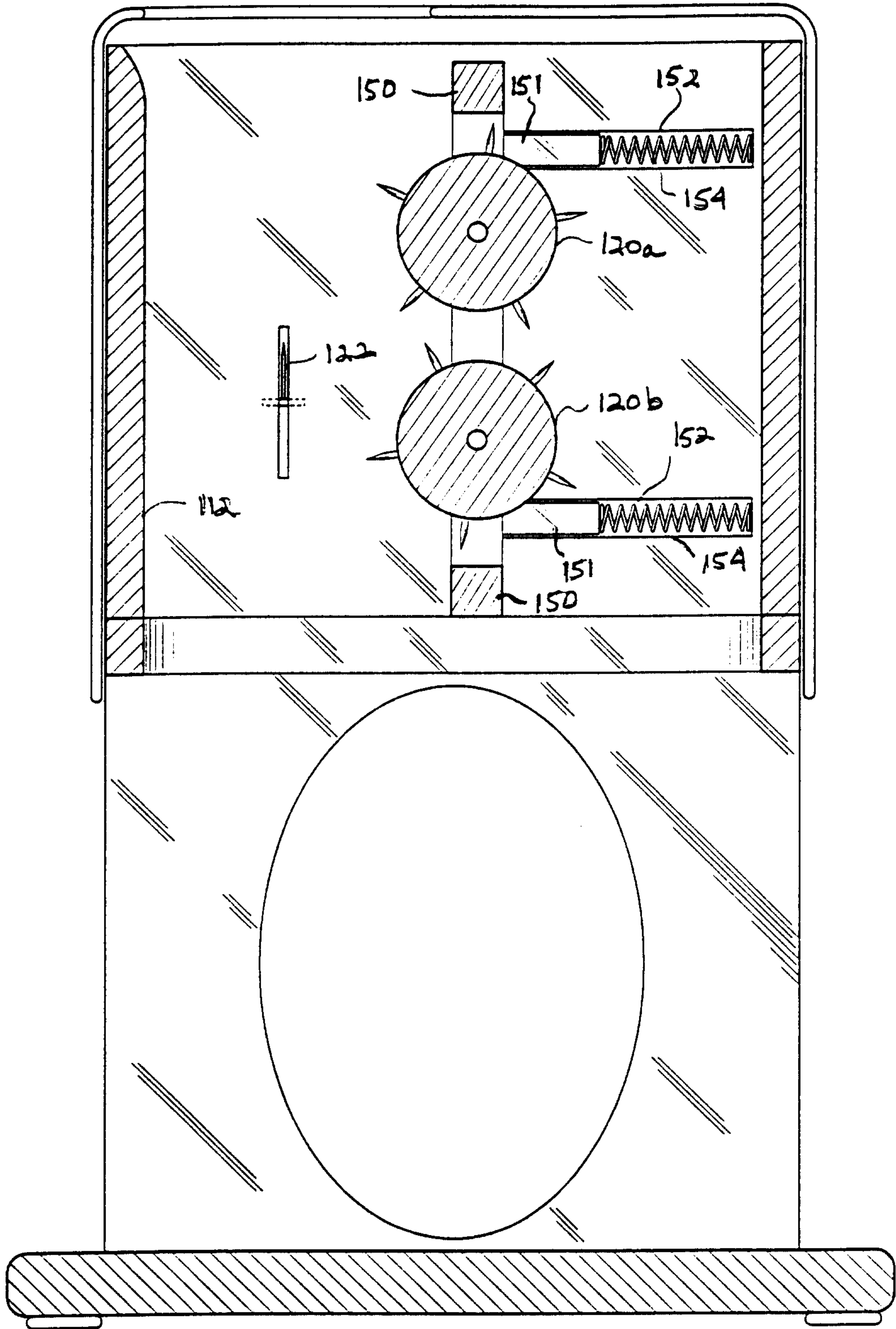

FIG. 9

