



- (51) International Patent Classification:
B65D 83/04 (2006.01) *B65D 5/38* (2006.01)
- (21) International Application Number:
PCT/IB2017/051347
- (22) International Filing Date:
8 March 2017 (08.03.2017)
- (25) Filing Language: English
- (26) Publication Language: English
- (30) Priority Data:
201621008220 9 March 2016 (09.03.2016) IN
- (71) Applicant: **ABBOTT HEALTHCARE PVT. LTD.**
[IN/IN]; 4, Corporate Park, Sion-Trombay Road, Maharashtra, Mumbai 400 071 (IN).
- (72) Inventors: **AMBUJAN, Jithin**; Abbott Healthcare Private Limited, A Wing, 1st Floor, Light Hall Building, Hiranandani Business Park, Saki Vihar Road, Chandivali, Andheri (East), Mumbai, Maharashtra 400 072 (IN).

BALASUBRAMANIAN, Abhilash; Abbott Healthcare Private Limited, A Wing, 1st Floor, Light Hall Building, Hiranandani Business Park, Saki Vihar Road, Chandivali, Andheri (East), Mumbai, Maharashtra 400 072 (IN). **MISHRA, Rajesh**; Abbott Healthcare Private Limited, A Wing, 1st Floor, Light Hall Building, Hiranandani Business Park, Saki Vihar Road, Chandivali, Andheri (East), Mumbai, Maharashtra 400 072 (IN). **MESTA, Vikrant**; Abbott Healthcare Private Limited, A Wing, 1st Floor, Light Hall Building, Hiranandani Business Park, Saki Vihar Road, Chandivali, Andheri (East), Mumbai, Maharashtra 400 072 (IN).

- (74) Agent: **SINGH, Manisha**; Lex Orbis Intellectual Property Practice, 709-710, Tolstoy House, 15-17, Tolstoy Marg, New Delhi 110001 (IN).
- (81) Designated States (*unless otherwise indicated, for every kind of national protection available*): AE, AG, AL, AM, AO, AT, AU, AZ, BA, BB, BG, BH, BN, BR, BW, BY, BZ, CA, CH, CL, CN, CO, CR, CU, CZ, DE, DJ, DK, DM, DO, DZ, EC, EE, EG, ES, FI, GB, GD, GE, GH, GM, GT,

[Continued on next page]

(54) Title: APPARATUS FOR MAINTAINING AND FACILITATING ACCESS TO BLISTER-PACKS

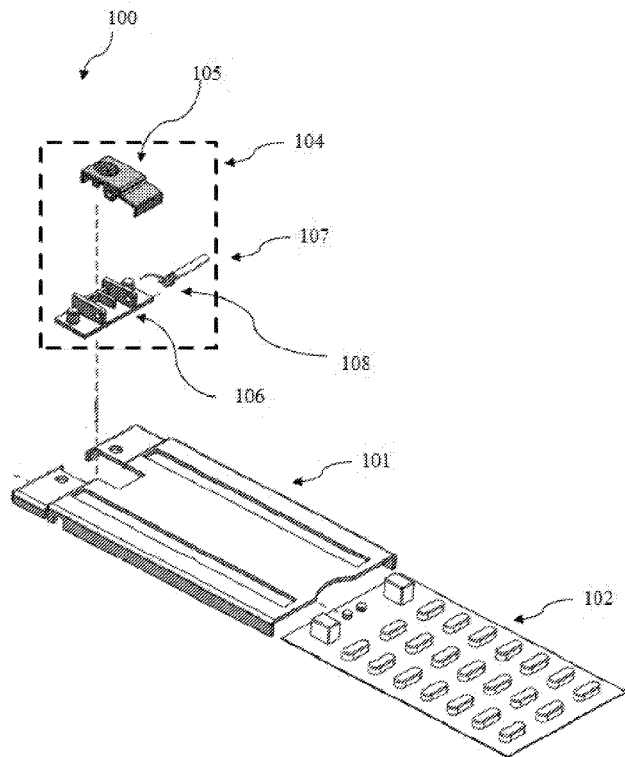

FIGURE 1

(57) Abstract: The present subject matter defines an apparatus for maintaining and accessing blister-packs and rendering access thereto. The apparatus comprises an enclosure (101) defined by a roof (203) and at least two side-walls (202-1, 2) to receive a sheet (102), wherein said enclosure (101) comprises a slot (204) running across said roof (203) to receive a protruding portion (303) of said sheet (102) to limit a movement of said at least one sheet (102) across said enclosure (101); and a manually operable locking-mechanism (104) implemented within the enclosure (101) to selectively lock the sheet (102) within the enclosure (101) and permit said limited movement of the sheet (102).



HN, HR, HU, ID, IL, IN, IR, IS, JP, KE, KG, KH, KN, KP, KR, KW, KZ, LA, LC, LK, LR, LS, LU, LY, MA, MD, ME, MG, MK, MN, MW, MX, MY, MZ, NA, NG, NI, NO, NZ, OM, PA, PE, PG, PH, PL, PT, QA, RO, RS, RU, RW, SA, SC, SD, SE, SG, SK, SL, SM, ST, SV, SY, TH, TJ, TM, TN, TR, TT, TZ, UA, UG, US, UZ, VC, VN, ZA, ZM, ZW.

LU, LV, MC, MK, MT, NL, NO, PL, PT, RO, RS, SE, SI, SK, SM, TR), OAPI (BF, BJ, CF, CG, CI, CM, GA, GN, GQ, GW, KM, ML, MR, NE, SN, TD, TG).

(84) Designated States (unless otherwise indicated, for every kind of regional protection available): ARIPO (BW, GH, GM, KE, LR, LS, MW, MZ, NA, RW, SD, SL, ST, SZ, TZ, UG, ZM, ZW), Eurasian (AM, AZ, BY, KG, KZ, RU, TJ, TM), European (AL, AT, BE, BG, CH, CY, CZ, DE, DK, EE, ES, FI, FR, GB, GR, HR, HU, IE, IS, IT, LT,

Declarations under Rule 4.17:

- as to applicant's entitlement to apply for and be granted a patent (Rule 4.17(ii))
- as to the applicant's entitlement to claim the priority of the earlier application (Rule 4.17(iii))

Published:

- with international search report (Art. 21(3))

APPARATUS FOR MAINTAINING AND FACILITATING ACCESS TO BLISTER- PACKS

TECHNICAL FIELD

The present invention generally relates to a compliance-pack. More particularly, the
5 invention pertains to a compliance-pack incorporating a child resistant (CR) and senior
friendly (SF) accessibility of contents therein.

BACKGROUND

Encapsulated medicines and non-medicinal items for human consumption (such as a
10 chewing-gum) come wrapped in blister-packs. Such blister-packs usually provide child
resistant (CR) and senior friendly (SF) features. By way of examples, US20040045858,
US7617935, US6460693, US20090184023, US20110114512, US6789677, US7588149, and
US7591372 describe blister packs with snap-locks that can be squeezed from both ends
simultaneously and the blister can be pulled out. The blister strips in these examples is
15 usually not allowed to be completely pulled out from the blister packs. The blister packs can
be either paper or plastic. However, these examples describe a complicated design and
require skills which may not be available with senior-citizens, especially with senior citizens
having impaired physical, cognitive skills, poor eyesight, and dexterity related issues.

20 By way of other examples, US20120160726, US20040256277, US8365916,
US20120267261, and US20070261984, describe containers or housings for one or more
blister strips with clip locking mechanism that can be pressed to obtain the blister strip. In
addition, the containers also have the mechanism to prevent the blister-strip from being
pulled put completely. However, such compliance-packs/containers usually exhibit a
25 complicated architecture and incur substantially-high manufacturing costs. More-
specifically, the manufacturing of such containers indispensably requires plastic-materials.

By way of another example, US7959005 describes a blister container made of
cardboard. The container enables consumption of a tablet from a blister strip in an orderly
30 manner, which is achieved by a stopper that allows the blister strip to come out in an orderly
pattern. The tablet from a blister shell is removed when the blister shell is aligned with
predefined recess on an outer pack. The stopper is designed such that it obstructs the blister
shell which has the tablet filled in it. Upon removing the tablet, the blister shell gets

compressed and passes through the stopper. This enables the blister strip to be pulled out till a blister shell includes a tablet. In addition, the container is formed by folding the cardboard and using adhesive bonding for securely closing two sides and keeping open two sides for pulling out blister strip and/or replacing a new blister strip. The container is then packed in a package made of cardboard for enclosing the entire-arrangement of the blister strip and the blister container.

By way of one another example, US8869984 describes a packaging structure in which the blister strip/pack is bonded using an adhesive to a blister pack retainer. The blister pack retainer is then enclosed in a slidable-cover. The slidable-cover and the blister pack retainer includes tab portions which cooperate to restrain the blister pack retainer from being fully withdrawn from the slidable cover. The slidable cover and the blister retainer pack are made of cardboard and the tab-portions are obtained by folding certain portions of the cardboard. In addition, the blister strip is fixed on the blister pack retainer using an adhesive.

The compliance packs depicted in US7959005 and US8869984 are simpler in their configuration and tend to incur low manufacturing costs at least due to the usage of cardboard. However, since the blister-strip may be either fixed on an intermediate pack (blister retainer pack) or enclosed in an intermediate pack with two sides open (container), the resulting locking- feature fails to provide a secure locking mechanism.

Thus, there remains a need for an improved blister packs or compliance-packs that are highly resistant to a child-access and yet remain easy for usage by senior-citizens, while incorporating a simpler and cost-effective architecture to minimize manufacturing costs.

SUMMARY

This summary is provided to introduce a selection of concepts in a simplified format that are further described in the detailed description of the invention. This summary is neither intended to identify key or essential-inventive concepts of the invention, nor is it intended for determining the scope of the invention.

In accordance with the purposes of the invention, the present invention as embodied and broadly described herein describes an assembly for maintaining blister-packs and rendering access thereto. The assembly comprises an enclosure defined by a roof and at least two side-walls to receive a sheet, wherein said enclosure comprises a slot running across

said roof to receive a protruding portion of said sheet to limit a movement of said at least one sheet across said enclosure; and a manually operable locking-mechanism implemented within the enclosure to selectively lock the sheet within the enclosure and permit said limited movement of the sheet.

5

The assembly may be a compliance pack for encapsulated items (such as medicines, chewing-gum) and incorporates robust child-resistance (CR) and senior-friendly (SF) features, while exhibiting a substantially simpler architecture with low-manufacturing costs. The advantages of the present invention include, but not limited to, a simple and easy to use compliance pack. As a part of its operation, the compliance-pack necessitates performance of two simultaneous user-actions to dislodge the encapsulated items from the compliance pack for an eventual consumption.

10

Further, the locking mechanism securely locks the blister strip with the housing and the blister-tray using the clip assembly. This provides enhanced protection from the blister strip being accidentally pulled or the compliance pack being torn open, since the blister strip is secured with both the housing and the blister tray. Still further, the locking mechanism also facilitates the blister strip to be automatically locked inside the housing upon having been pushed inside the housing, thereby doing away with the need to keep the blister-strip separately and securely.

15

20

Furthermore, the design and manufacturing of the compliance pack is substantially simple, as the locking mechanism and sliding mechanism have been achieved by ways of projection and cavities carved within the blister tray, blister strip, and the housing. Additionally, the housing and the blister tray may be constituted by cardboard or analogous material, while the clip-assembly is made of plastic and simple resilient components, e.g. a small-sized torsion spring, constituting the locking mechanism. Overall, the present subject matter at least enables a substantially simpler and cost-effective compliance pack, while rendering the CR and SF features.

25

These and other aspects as well as advantages will be more clearly understood from the following detailed description taken in conjunction with the accompanying drawings and claims.

30

BRIEF DESCRIPTION OF DRAWINGS

To further clarify advantages and aspects of the invention, a more particular description of the invention will be rendered by reference to specific embodiments thereof, which is illustrated in the appended drawings. It is appreciated that these drawings depict
5 only typical embodiments of the invention and are therefore not to be considered limiting of its scope. The invention will be described and explained with additional specificity and detail with the accompanying drawings, which are listed below for quick reference.

Figure 1 illustrates an exploded perspective view of a compliance pack in accordance with an embodiment of the present invention.

10 **Figure 2** illustrates a perspective view of a blister tray of the compliance pack of Figure 1, in accordance with an embodiment of the present invention.

Figure 3 illustrates a perspective view of a blister strip of the compliance pack of Figure 1, in accordance with an embodiment of the present invention.

15 **Figure 4** illustrates a perspective view of a clip assembly of the compliance pack of Figure 1, in accordance with an embodiment of the present invention.

Figures 5a, 5b, & 5c illustrate perspective views of a housing of the compliance pack of Figure 1, in accordance with an embodiment of the present invention.

20 **Figures 6a, 6b, & 6c** illustrate cross-sectional view of sequential steps operation of the compliance pack of Figure 1, in accordance with an embodiment of the present invention.

Figures 7a, 7b, & 7c illustrate perspective view of the compliance pack of Figure 1 in accordance with sequential steps of Figures 6a, 6b, & 6c, in accordance with an embodiment of the present invention.

25 It may be noted that to the extent possible, like reference numerals have been used to represent like elements in the drawings. Further, those of ordinary skill in the art will appreciate that elements in the drawings are illustrated for simplicity and may not have been necessarily drawn to scale. For example, the dimensions of some of the elements in the drawings may be exaggerated relative to other elements to help to improve understanding of aspects of the invention. Furthermore, the one or more elements may have been represented

in the drawings by conventional symbols, and the drawings may show only those specific details that are pertinent to understanding the embodiments of the invention so as not to obscure the drawings with details that will be readily apparent to those of ordinary skill in the art having benefit of the description herein.

5 DETAILED DESCRIPTION

It should be understood at the outset that although illustrative implementations of the embodiments of the present disclosure are illustrated below, the present invention may be implemented using any number of techniques, whether currently known or in existence. The present disclosure should in no way be limited to the illustrative implementations, drawings, and techniques illustrated below, including the exemplary design and implementation illustrated and described herein, but may be modified within the scope of the appended claims along with their full scope of equivalents.

The term “some” as used herein is defined as “none, or one, or more than one, or all.” Accordingly, the terms “none,” “one,” “more than one,” “more than one, but not all” or “all” would all fall under the definition of “some.” The term “some embodiments” may refer to no embodiments or to one embodiment or to several embodiments or to all embodiments. Accordingly, the term “some embodiments” is defined as meaning “no embodiment, or one embodiment, or more than one embodiment, or all embodiments.”

The terminology and structure employed herein is for describing, teaching and illuminating some embodiments and their specific features and elements and does not limit, restrict or reduce the spirit and scope of the claims or their equivalents.

More specifically, any terms used herein such as but not limited to “includes,” “comprises,” “has,” “consists,” and grammatical variants thereof do NOT specify an exact limitation or restriction and certainly do NOT exclude the possible addition of one or more features or elements, unless otherwise stated, and furthermore must NOT be taken to exclude the possible removal of one or more of the listed features and elements, unless otherwise stated with the limiting language “MUST comprise” or “NEEDS TO include.”

Whether or not a certain feature or element was limited to being used only once, either way it may still be referred to as “one or more features” or “one or more elements” or “at least one feature” or “at least one element.” Furthermore, the use of the terms “one or more” or “at least one” feature or element do NOT preclude there being none of that feature

or element, unless otherwise specified by limiting language such as “there NEEDS to be one or more” or “one or more element is REQUIRED.”

Unless otherwise defined, all terms, and especially any technical and/or scientific terms, used herein may be taken to have the same meaning as commonly understood by one
5 having an ordinary skill in the art.

Reference is made herein to some “embodiments.” It should be understood that an embodiment is an example of a possible implementation of any features and/or elements presented in the attached claims. Some embodiments have been described for the purpose of illuminating one or more of the potential ways in which the specific features and/or
10 elements of the attached claims fulfil the requirements of uniqueness, utility and non-obviousness.

Use of the phrases and/or terms such as but not limited to “a first embodiment,” “a further embodiment,” “an alternate embodiment,” “one embodiment,” “an embodiment,” “multiple embodiments,” “some embodiments,” “other embodiments,” “further
15 embodiment”, “furthermore embodiment”, “additional embodiment” or variants thereof do NOT necessarily refer to the same embodiments. Unless otherwise specified, one or more particular features and/or elements described in connection with one or more embodiments may be found in one embodiment, or may be found in more than one embodiment, or may be found in all embodiments, or may be found in no embodiments. Although one or more
20 features and/or elements may be described herein in the context of only a single embodiment, or alternatively in the context of more than one embodiment, or further alternatively in the context of all embodiments, the features and/or elements may instead be provided separately or in any appropriate combination or not at all. Conversely, any features and/or elements described in the context of separate embodiments may alternatively be
25 realized as existing together in the context of a single embodiment.

The present invention discloses a compliance pack for solids that incorporates child resistance (CR) and senior friendly (SF) features. In particular, the design and structure of the compliance pack enable a user to perform two simultaneous operations for removing a blister from the compliance pack.

30 **Figure 1** illustrates an exploded perspective view of an assembly (100), hereinafter referred to as a compliance pack (100), in accordance with an embodiment of the present

invention. The compliance-pack (100) comprises an enclosure (101) defined by a roof (shown in Fig. 2) and at least two side-walls (shown in Fig. 2) to receive a sheet (102), wherein said enclosure (101) comprises a slot (shown in Fig. 2) running across said roof to receive a protruding portion (shown in Fig. 3) of said sheet (102) to limit a movement of
5 said at least one sheet (102) across said enclosure (101).

The enclosure (101) may be a blister-tray (101) that is adapted to receive a 'blister-strip' (102) or a blister-pack (102) having a plurality of pre-formed plastics for accommodating a plurality of products. While the blister-strip (102) is slideably engaged with the blister-tray (101) through a sliding-mechanism, the extent of such slide of the
10 blister-strip (102) is defined by the length of the slot (shown in Fig. 2). As may be understood, the slot receiving the protruding portion obstructs a linearly-moving protrusion at its two end-points and accordingly the blister-tray (101) is allowed a limited translation-movement. Such protruding-portion protrudes from one of the faces of the blister-pack (102). Further, the enclosure (101) comprises at least one opening at at-least one side to
15 allow an extension of said enclosed sheet (102) outside the boundary of said enclosure (101) as and when the sheet (102) undergoes said limited-movement,

Further, a manually operable locking-mechanism (104) is attached to the enclosure (101) to selectively lock the sheet (102) within the enclosure (101) and permit said limited movement of the sheet (102). More specifically, the blister-strip (102) is attached onto the
20 blister-tray (101) through a clip-assembly (104) acting as said manually operable locking-mechanism.

The clip assembly (104) may be composed of a clip (105), a clip base (106), a guide (107), and a torsion spring (108). In order to interface with the lock, the blister-strip (102) comprises another protruding portion for interacting with the locking-mechanism (104) in a
25 locked-state, thereby altogether arresting any movement of the blister-strip (102) within the enclosure (101) as long as the clip-assembly (104) lies in a locked state.

As may be understood, the compliance pack (100) including the blister-pack can be easily assembled at a pharmaceutical-industry or any other fast-moving consumer goods
30 (FMCG) industry meant for packing edible items in blister-packs. In addition, the blister-packs (102) forming a part of the compliance pack (100) may be replaceable by other blister-packs (102) of pre-defined dimensions with respect to a particular enclosure (101).

Figure 2 illustrates a perspective view of the enclosure (101) or the blister-tray (101) of the compliance-pack (100) of Figure 1, in accordance with an embodiment of the present invention. The blister-tray (101) includes a first portion (200) and a second portion (201), such that while an area of the first portion (200) is larger than the area of the second portion (201), both portions (200) and (201) are integral to each other. The enclosure (101) is defined by two-side walls (202-1) and (202-2) extending along the sides of the first and second portions (200, 201), and a roof (203) supported between the side walls (202-1) and (202-1). The enclosure (101) may be created in a monolithic-form by molding a base material (e.g. a card-board material) in the pre-defined manner. As would be understood, the height of the side walls (202-1) and (202-2) may be defined in order to accommodate the blister strip (102) in a snug-fit manner.

Further, the roof (203) of the enclosure (101) may be extruded to create the slots (204) as running along the length of the roof (203). As shown in Fig.2, the guiding slots (204) as carved within the roof (203) are parallel and spaced-apart with respect to each other. Moreover, the slots (204) are confined within the first portion (200) of the enclosure (101). As already explained before, the slots (204) receive the protruding portion from the blister-pack (102) placed beneath the slots (204) and accordingly permit the linear-movement of the blister-pack (102) by a limited extent.

Further, the blister tray (101) includes an aperture (205) as carved within the center of the roof (203) at the second portion (201) and partly within the center of the first portion (200). The aperture (205) so constituted is disposed at the junction of the first portion (200) and the second portion (201). The orifices (206) are carved within the roof at the second portion (201) and also lie equidistant from the aperture (205) within the second portion (201). The aperture (205) within the roof at the first portion (200) is positioned between the pair of guiding-slots (204), such that the slots (204) are located at either side of the aperture (205).

As depicted in the figure, while the aperture (205) spans across the entire length of the roof of the second portion (201), it extends only by a pre-determined length within the first portion (200). More specifically, the aperture (205) and the pair of orifices (206) are designed to accommodate the clip-assembly (104) within the enclosure (101), as explained later with respect to Fig. 4.

Further, the blister tray (101) includes a pair of receptacles (207) carved-out at either of the side-walls (202-1, 2) at the bottom-area of the tray (101). The two receptacles (207) are incorporated at identical locations within the two side-walls (202-1, 2) and accordingly disposed directly-opposite to each-other.

5 **Figure 3** illustrates a perspective view of the sheet (102) or the blister strip (102) of the compliance pack (100) of Figure 1, in accordance with an embodiment of the present invention. The blister strip (102) can be manufactured using any suitable technique as known in the art. In one example, the blister strip (102) is made by thermoforming plastic and comprises an open end holding a tablet sealed by an aluminum foil.

10 The blister strip (102) includes a first region (300) and a second region (301), such that the first region (300) has a larger-area than the second region (301). Within the first region (300), the surface comprises a plurality of evenly-spaced chambers (302) or pre-formed plastics that accommodate a plurality of edible or medicinal products, such as pharmaceutical pill or tablet or capsule, which are disposed on a front side of the blister strip
15 (102) in the first region (300). The item in each of the spaced chambers (302) is sealed using a film cover on a rear side of the blister strip (102). As would be understood by a person skilled in the art, the edible or medicinal item is released from a particular chamber by applying a downward pressure to the selected-chamber in order to tear-open the film cover for releasing the item.

20 Further, at the surface of the second region (301) of the blister-strip (102), a pair of protruding portions (303) or guiding-projections (303) is disposed and protrudes upwards from surface of the blister-strip (102). The guiding-projections (303) are symmetrically disposed within the second-region (301) and positioned near the edges of the blister-strip (102). As mentioned previously, the end points of the slots (204) obstruct the protruding
25 portions (303) and accordingly define the limits of translation-motion as undertaken by the blister-strip (102). In other words, the guiding projections (303) upon getting obstructed by the end-points of the slots (204) prevent a complete pull-out of the blister-strip (102) from the compliance-pack (100).

30 Further, the blister strip (102) includes another set of protruding portions (304) or a pair of stoppers (304) symmetrically disposed within the second region (301) and positioned between the guiding-projections (303). Such pair of stoppers (304) may be disposed in middle of the second region (301) and engage with the clip (105) during the locked

conditions. Accordingly, the engagement of the clip (105) with the stoppers (304) prevents the blister strip (102) from being completely pulled out.

Figure 4 illustrates a perspective view of an assembled clip assembly (104) of the compliance pack (100) of Figure 1, in accordance with an embodiment of the present invention. As illustrated in Figure 1 earlier, the clip-assembly (104) includes the clip (105), the clip base (106), a guide-pin (107), and the torsion spring (108). The clip (105) includes a release tab (400) and a locking panel (401). The clip base (106) is designed to accommodate the guide-pin (107) and the torsion spring (108). The clip base (106) also includes a pair of locking projections (402) that are received by the recesses (206) of the blister-tray (101), thereby leading to the engagement of the pair of locking projections (402) with the blister-tray (101) and in-turn leading to engagement of the locking panel (401) with the pair of stoppers (304) of the blister strip (102). The clip-assembly (104) may be preferably formed of hard-plastic or other suitable materials.

The locking mechanism (104) or the clip-assembly (104) is attached to said enclosure (101) and is controllable by a user to facilitate the limited movement of said sheet (102). As explained later, the movement is triggered by an actuation of the locking mechanism (104) and a manually-done pulling of the sheet (102).

Further, while the aforesaid locking mechanism (104) has been referred as a clip-lock actuated by a clip-press, the same may be extended to cover other types of locking-mechanisms as well, such as a spring-loaded lock actuated by lift of a cap, and a slider-lock actuated by a sliding-action.

Figures 5a, 5b, & 5c illustrate perspective views of a housing (103) of the compliance pack (100) of Figure 1, in accordance with an embodiment of the present invention. The housing (103) may be manufactured as a monolithic material from paper or paperboard or cardboard or a similar material through molding. Further, as may be understood, the rectangular-space defined within the housing (103) receives the blister tray (101) and the blister strip (102). The clip-assembly (104) is received externally within the space defined by the aperture (205).

The housing (103) includes a top panel (500), a bottom panel (501), and side panels (502-1) and (502-2). Further, the housing (103) includes an end stop panel (503) in sealing-engagement with the top-panel (500) and the bottom panel (501) at first end of the side

panels (502-1) and (502-2). In one example, end stop panel (503) is folded over and glued to the top panel (500), the bottom panel (501), and the side panels (502-1) and (502-2). In another example, the top panel (500), the bottom panel (501), and the side panels (502-1) and (502-2) are shaped by molding to achieve the housing (103). Thus, the housing (103) as
5 obtained is a cuboid having one side as open and another side as closed. The open side of the housing (103) allows entry of the blister strip (102) within the enclosure (100) and later on the partial-pull of the blister-strip (102) as and when required.

In an embodiment, the top panel (500) and the bottom panel (501) may also include appropriate provisions for enabling a stable-accommodation of the blister strip (102) within
10 the enclosure (100).

Further, the top panel (500) and the end stop panel (503) includes a recess (504) defined to accommodate the release tab (400) of the clip (105). The release-tab (400) allows its depression by a user to cause disengagement of a locking-panel (401) from the pair of stoppers (303) at the blister strip (102) and thereafter permits a pulling-out of the blister strip
15 (102). Owing to the provision of the torsional-spring (108), the release-tab (400) returns back to its un-disturbed position upon having been released by the user.

Further, the side panels (502-1) and (502-2) include a pair of tabs (505) or inward-protrusions that have been carved-out within the side panels (502-1, 2). The pair of inward-protrusions (505) are disposed directly opposite with respect to each other and closer to the
20 end stop panel (503). Further, the pair of inward protrusions (505) are adapted to be received within the correspondingly-shaped receptacles (207) at the blister-tray (101) in a snap-fit configuration. Thus, the pair of tabs (502) and the pair of tab receptacles (207) securely engage the blister tray (101) within the housing (103) or interlock the blister tray (101) and the housing (103).

Further, the bottom panel (501) includes a pair of perforations (506) symmetrically
25 disposed at the bottom surface. Upon receipt of blister-tray (101) and blister-sheet (102) within the housing (103), the pair of perforations (506) get axially-aligned with the pair of orifices (206) of the blister tray (101) and also with the pair of locking projections (402) of the clip-base (106).

Similarly, the recess (504) of the housing (103) gets aligned with the analogously-shaped aperture (205) of the blister tray (101). As may be understood, the recess (504) of the
30

housing (103) and the aperture (205) of the enclosure (101) coincide with each other to define a space for implementing said locking mechanism (104).

Thereafter, as a part of fastening mechanism, a pair of fasteners such as screws or rivets may be inserted into the perforations (506) of the bottom-panel (501) from the bottom, thereby leading to fastening of the housing (103), the blister-tray (101), the locking mechanism (104) as a 'single' unit and accordingly a secure-engagement of the housing (103) with the blister tray (101). Moreover, the blister-strip (102) also gets accommodated in a rigid manner within the housing (103), owing to its interaction with the clip assembly (104). Thus, the locking mechanism (104) is achieved by ways of projection and cavities incorporated into the blister-tray (101), the blister strip (102), the housing (103), and the clip assembly (104).

Figures 6 & 7 illustrates sequential steps operation of the compliance pack of Figure 1, in accordance with an embodiment of the present invention.

Figures 6(a) and 7(a) illustrate a cross-sectional view and perspective view of the assembled compliance pack (100), respectively. As is evident from the figures, the blister tray (101) is in sealing engagement with the housing (103) through the clip assembly (105). The locking panel (401) is in engagement with the pair of stoppers (304) to lock the blister strip (102) and consequently, the pair of guiding-projections (303) is positioned at the first end of the pair of guiding slots (204). This prevents the blister strip (102) from being easily withdrawn from the housing (103), thereby providing the CR feature.

Figures 6(b) and 7(b) illustrate a cross-sectional view and perspective view of the assembled compliance pack (100), respectively, when the release tab (400) of the clip (105) is depressed. Upon depressing the release tab (400) sufficiently, the locking panel (401) disengages with the pair of stoppers (304) of the blister strip (102), thereby enabling the blister strip (102) to be pulled out.

Figures 6(c) and 7(c) illustrate a cross-sectional view and perspective view of the assembled compliance pack (100), respectively, when the blister strip (102) is being pulled out. Upon depressing the release tab (400) sufficiently and simultaneously pulling the blister strip (102) (represented by an arrow), the blister strip (102) slides through the pair of guiding slots (204) of the blister tray (101). The blister strip (102) can be pulled out to either inspect the strip (102) or remove the solid item from the plurality of spaced chambers (302).

Since the removal of the blister strip (102) from the housing (103) requires a simultaneous/twin-action of depression of the clip (105), and pulling-out of the blister strip (102), the CR feature is realized. Further, since relatively small efforts are required to pull the blister strip (102) and insertion of the blister-strip back into the compliance-pack (100),
5 the SF feature is automatically rendered.

The blister strip (102) can pulled out until the pair of guiding projections (303) are obstructed by a distal end of the pair of guiding slots (204). This prevents the blister strip (102) from coming out completely outside the housing (103).

Further, upon pushing the blister strip (102) back into the tray (101) within the
10 housing (103), the blister strip (102) as directed by the pair of guiding slots (204) and the locking panel (401) automatically engages with the pair of stopper (304) and is restored to its original position or the locked-state as illustrated in the Figures 6(a) and 7(a). This leads to realization of the SF feature, as the blister strip (102) is easily accommodated within the compliance pack (100) in a secure and rigid manner, while requiring least efforts from the
15 user.

While certain present preferred embodiments of the invention have been illustrated and described herein, it is to be understood that the invention is not limited thereto. Clearly, the invention may be otherwise variously embodied, and practiced within the scope of the above description.

20

Claims:

1. An assembly comprising:

an enclosure (101) defined by a roof (203) and at least two side-walls (202-1, 2) to receive a sheet (102), wherein said enclosure (101) comprises a slot (204) running across said roof (203) to receive a protruding portion (303) of said sheet (102) to limit a movement of said at least one sheet (102) across said enclosure (101); and

a manually operable locking-mechanism (104) implemented within the enclosure (101) to selectively lock the sheet (102) within the enclosure (101) and permit said limited movement of the sheet (102).

2. The assembly as claimed in claim 1, wherein said sheet (102) received within the enclosure (101) is a blister-pack having a plurality of pre-formed plastics for accommodating a plurality of products, and wherein said portion (303) protrudes from one of the faces of said sheet (102).

3. The assembly as claimed in claim 1, wherein said sheet (102) received within the enclosure (101) comprises another protruding portion (304) for interacting with the locking mechanism (104) in a locked-state.

4. The assembly as claimed in claim 1, wherein said enclosure (101) comprises at least one opening at at-least one side to allow an extension of said enclosed sheet (102) outside the boundary of said enclosure (101) during the occurrence of said limited-movement.

5. The assembly as claimed in preceding claims, wherein said slot (204) receiving the protruding portion (303) allows a sliding of the enclosed sheet (102) during said limited movement and limits said sliding between two end-points of the slot (204).

6. The assembly as claimed in claim 1, wherein said locking mechanism (104) is attached to said enclosure (101) and is controllable by a user to facilitate said limited movement of said sheet (102), said movement being triggered by an actuation of said locking-mechanism (104) and a manually-done pulling of the sheet (102).

7. The assembly as claimed in claim 1, wherein said locking mechanism (104) comprises at least one of:

a clip-lock actuated by a clip-press;

a spring-loaded lock actuated by lift of a cap; and
a slider-lock actuated by a sliding-action.

8. The assembly as claimed in preceding claims, wherein said locking-mechanism (104)
5 enables an automatic-locking of said sheet (102) within the enclosure (101) upon a pushing-
back of said sheet (102) from outside into the enclosure (101).

9. The assembly as claimed in claim 1, further comprising:
a housing (103) defining a space to receive said enclosure (101).

10

10. The assembly as claimed in preceding claims, wherein said housing (103) and the
enclosure (101) are recessed from outside to accommodate and implement said locking
mechanism (104) in a space defined by coincidence of the recess (504) of said housing (103)
with the recess (205) of the enclosure (101).

15

11. The assembly as claimed in claims 9 and 10, wherein said housing (103) comprises at
least one inward-protrusion (505) at each of the opposite side-walls (502-1, 2) and wherein
said inward protrusions (505) are received within correspondingly-shaped receptacles (207)
provided at the opposite side-walls (202-1,2) of said enclosure (101) disposed inside the
20 housing (103) to interlock said enclosure (101) and said housing (103).

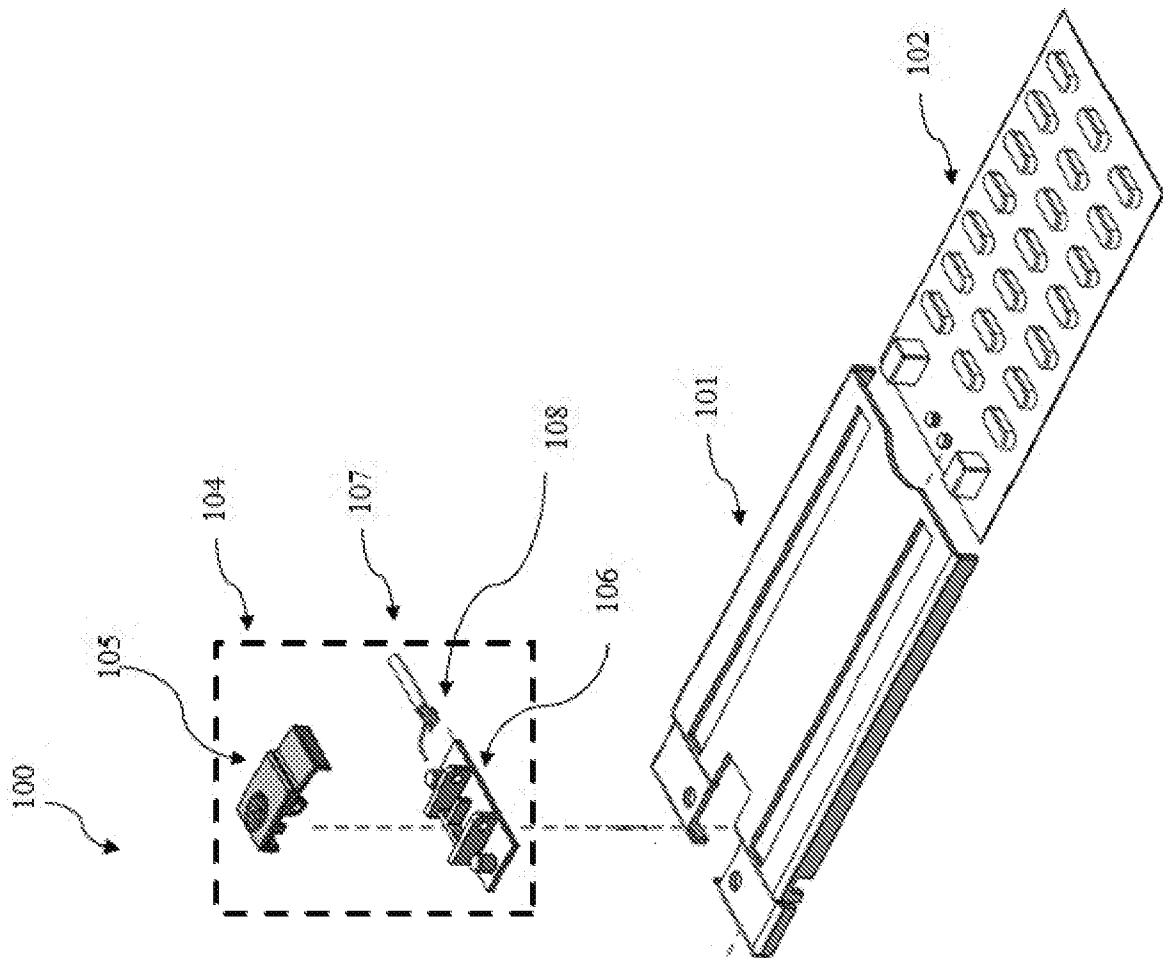

FIGURE 1

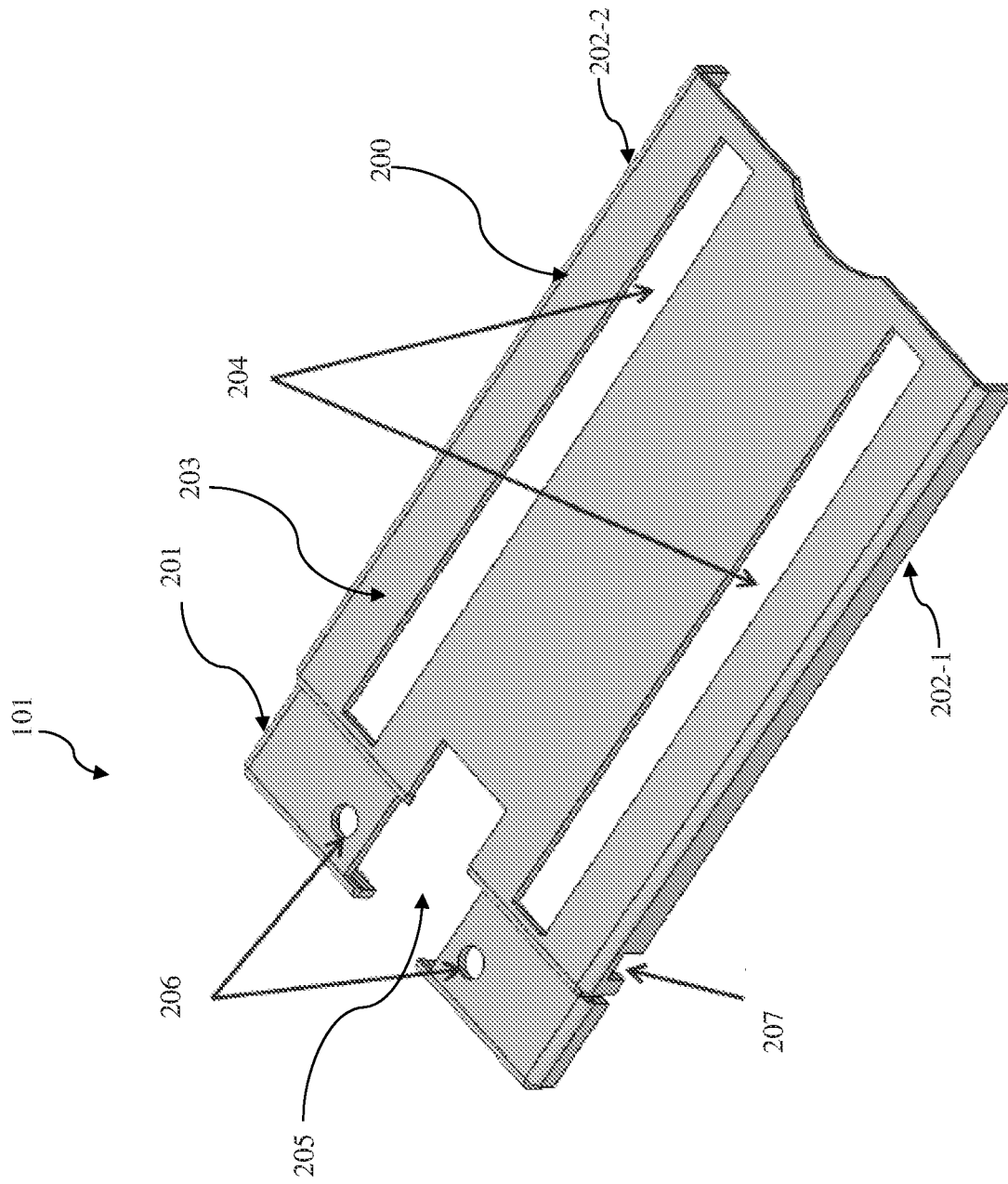

FIGURE 2

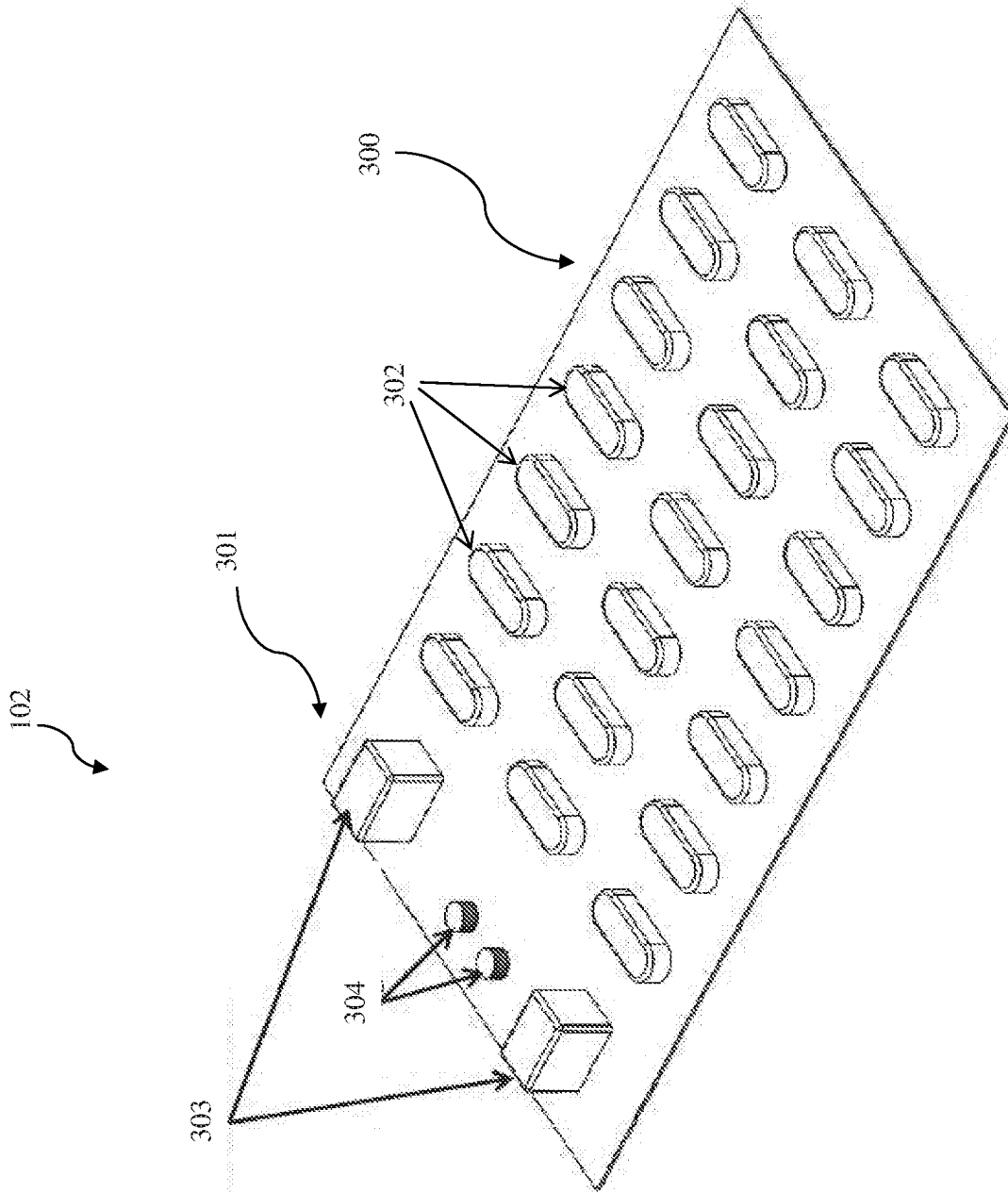

FIGURE 3

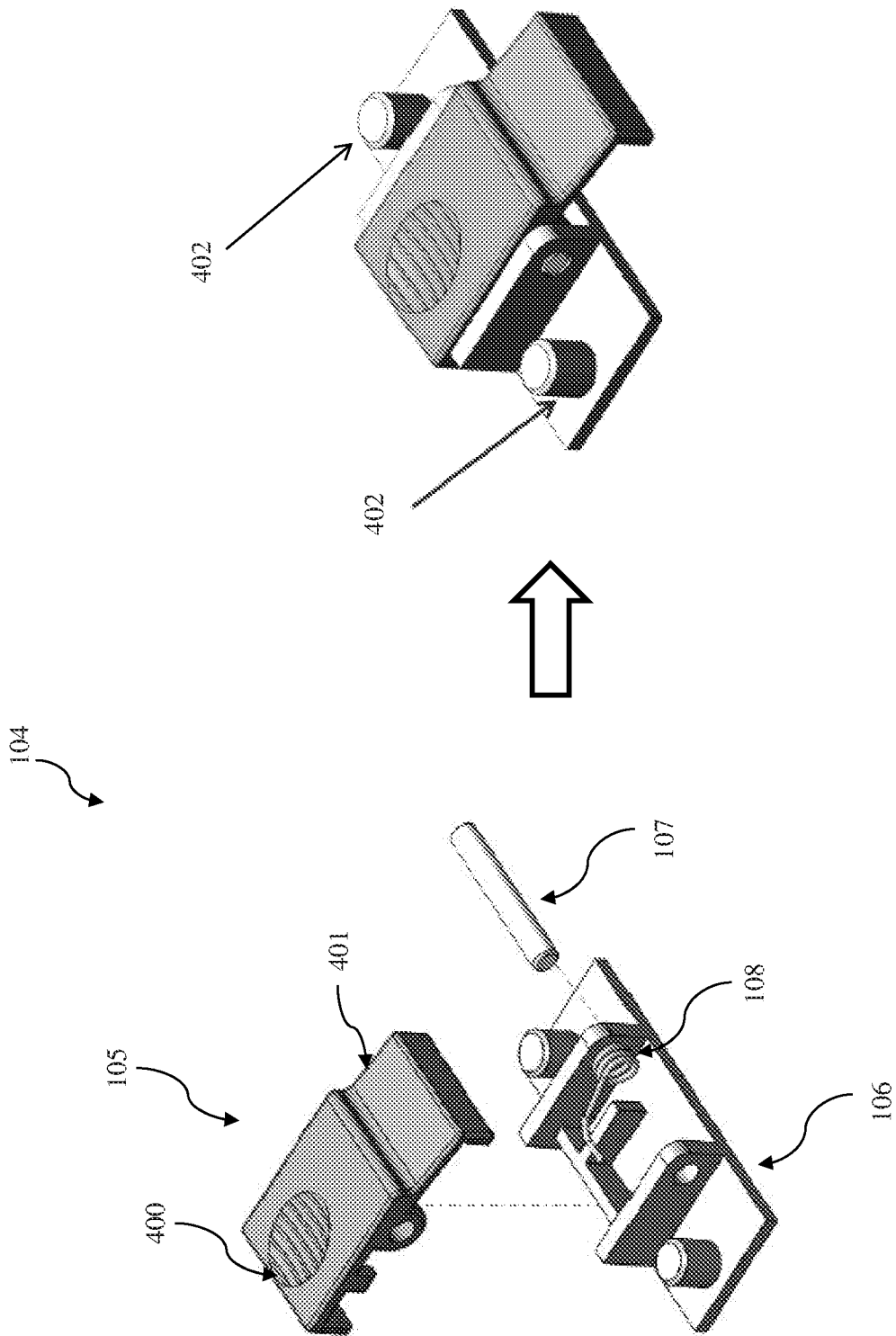

FIGURE 4

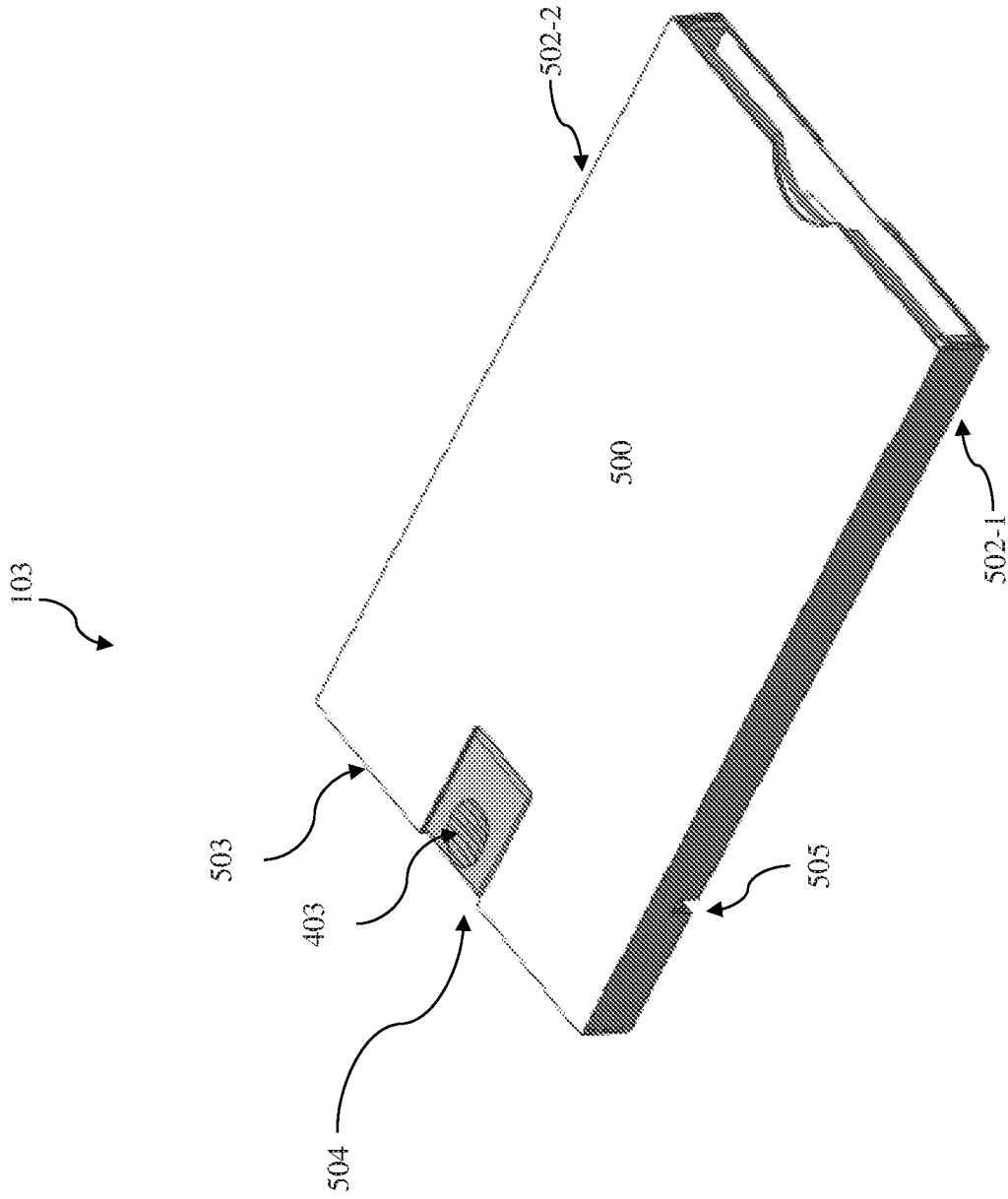

FIGURE 5a

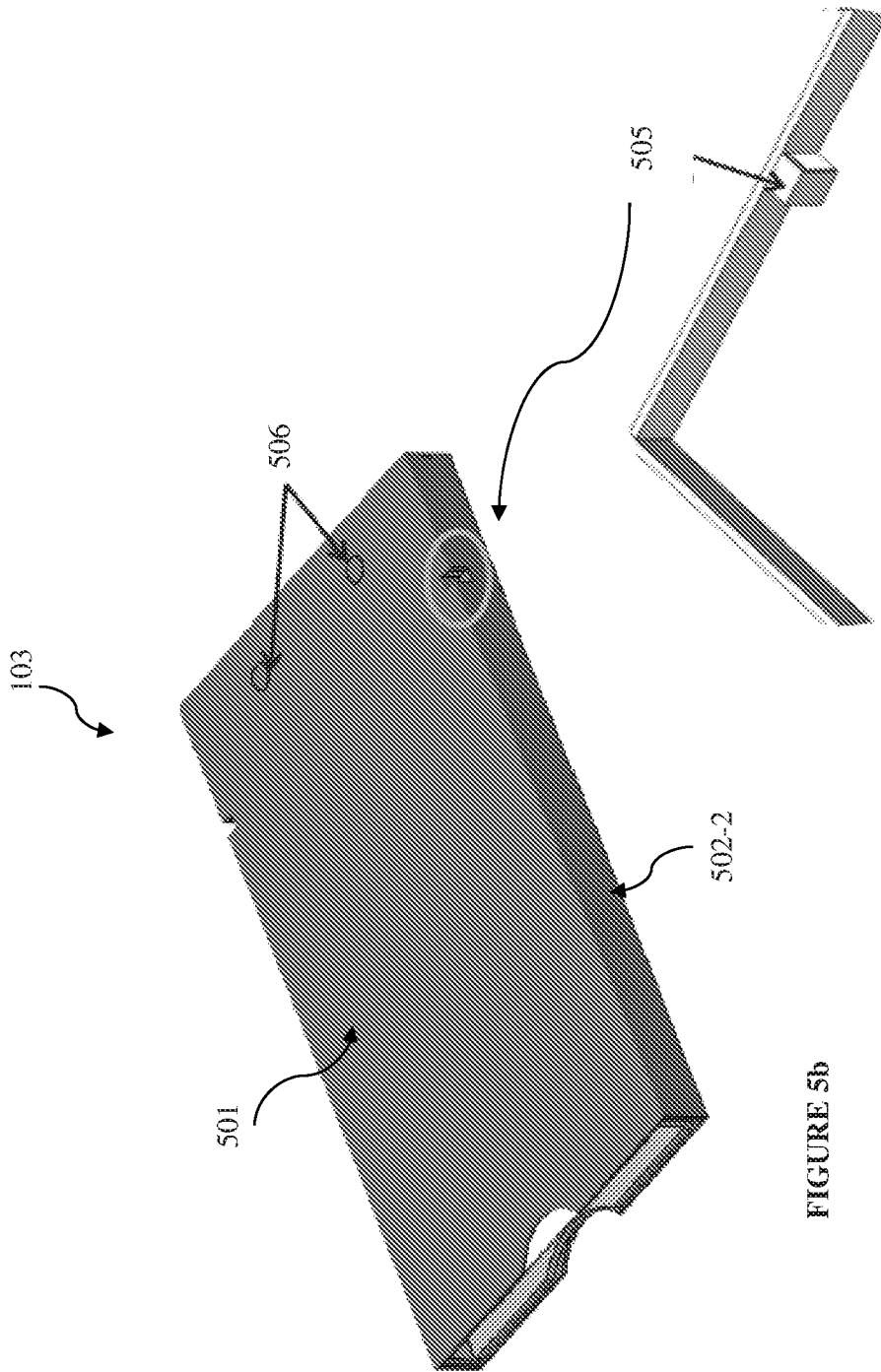
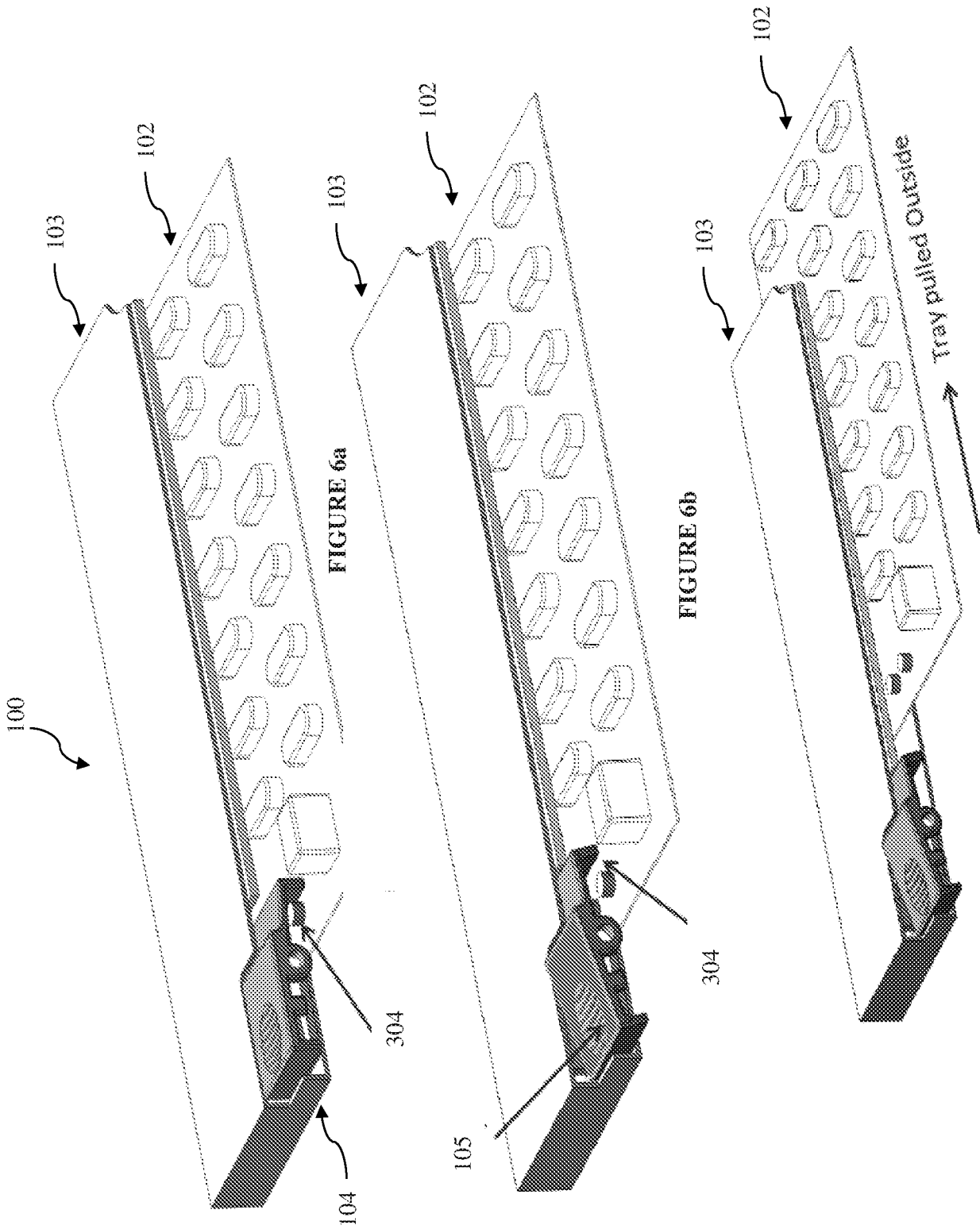
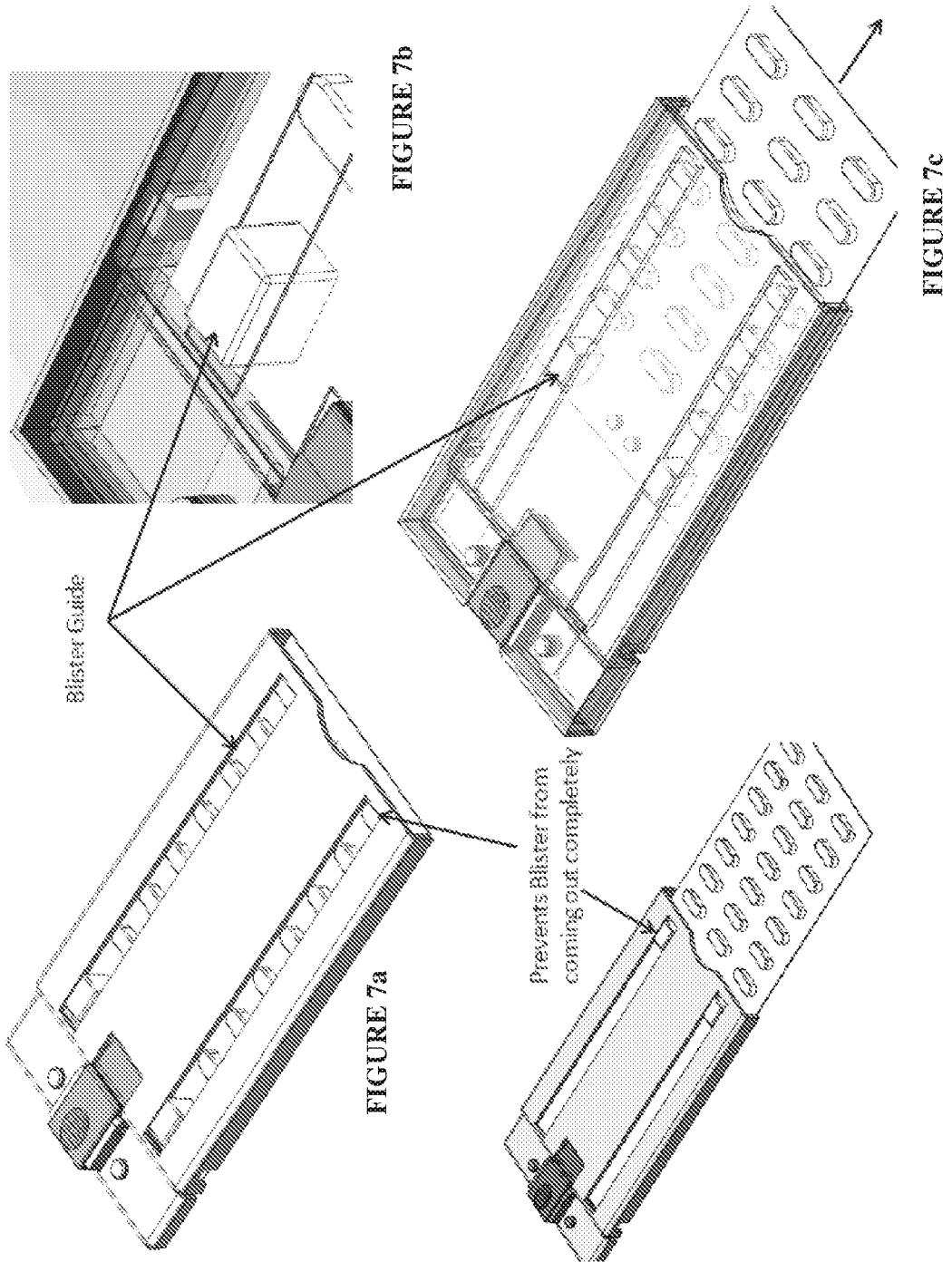

FIGURE 5b

FIGURE 5c



100



INTERNATIONAL SEARCH REPORT

International application No PCT/IB2017/051347

A. CLASSIFICATION OF SUBJECT MATTER INV. B65D83/04 ADD. B65D5/38				
According to International Patent Classification (IPC) or to both national classification and IPC				
B. FIELDS SEARCHED				
Minimum documentation searched (classification system followed by classification symbols) B65D				
Documentation searched other than minimum documentation to the extent that such documents are included in the fields searched				
Electronic data base consulted during the international search (name of data base and, where practicable, search terms used) EPO-Internal, WPI Data				
C. DOCUMENTS CONSIDERED TO BE RELEVANT				
Category*	Citation of document, with indication, where appropriate, of the relevant passages	Relevant to claim No.		
X	GB 2 451 850 A (FIELD GROUP PLC [GB]; CHESAPEAKE PLC [GB]) 18 February 2009 (2009-02-18)	1,2,5-7		
A	page 7, line 11 - page 9, line 11; figures 3-4J	3,4,8-11		

X	US 7 959 005 B2 (BERG NANCY [DE] ET AL) 14 June 2011 (2011-06-14)	1-5,9		
A	cited in the application column 4, line 1 - column 5, line 44; figures 1-9	6-8,10, 11		

Y	WO 99/65787 A1 (REMMOS PTY LTD [AU]; SOMMER PETER [AU]) 23 December 1999 (1999-12-23)	1,3-6,8		
A	the whole document	2,7,9-11		

-/--				
<table style="width: 100%; border: none;"> <tr> <td style="width: 50%; border: none;"><input checked="" type="checkbox"/> Further documents are listed in the continuation of Box C.</td> <td style="width: 50%; border: none;"><input checked="" type="checkbox"/> See patent family annex.</td> </tr> </table>			<input checked="" type="checkbox"/> Further documents are listed in the continuation of Box C.	<input checked="" type="checkbox"/> See patent family annex.
<input checked="" type="checkbox"/> Further documents are listed in the continuation of Box C.	<input checked="" type="checkbox"/> See patent family annex.			
* Special categories of cited documents :				
"A" document defining the general state of the art which is not considered to be of particular relevance "E" earlier application or patent but published on or after the international filing date "L" document which may throw doubts on priority claim(s) or which is cited to establish the publication date of another citation or other special reason (as specified) "O" document referring to an oral disclosure, use, exhibition or other means "P" document published prior to the international filing date but later than the priority date claimed	"T" later document published after the international filing date or priority date and not in conflict with the application but cited to understand the principle or theory underlying the invention "X" document of particular relevance; the claimed invention cannot be considered novel or cannot be considered to involve an inventive step when the document is taken alone "Y" document of particular relevance; the claimed invention cannot be considered to involve an inventive step when the document is combined with one or more other such documents, such combination being obvious to a person skilled in the art "&" document member of the same patent family			
Date of the actual completion of the international search	Date of mailing of the international search report			
17 May 2017	01/06/2017			
Name and mailing address of the ISA/ European Patent Office, P.B. 5818 Patentlaan 2 NL - 2280 HV Rijswijk Tel. (+31-70) 340-2040, Fax: (+31-70) 340-3016	Authorized officer Leijten, René			

INTERNATIONAL SEARCH REPORT

International application No

PCT/IB2017/051347

C(Continuation). DOCUMENTS CONSIDERED TO BE RELEVANT

Category*	Citation of document, with indication, where appropriate, of the relevant passages	Relevant to claim No.
Y	WO 2012/112538 A1 (MEADWESTVACO CORP [US]; GELARDI JOHN [US]; BAILEY RYAN A [US]; FALCON) 23 August 2012 (2012-08-23) paragraphs [0003], [0074] - [0081]; figures 1-5 -----	1,3-6,8
X,P	EP 3 015 390 A1 (MULTI PACKAGING SOLUTIONS UK LTD [GB]) 4 May 2016 (2016-05-04) paragraphs [0030] - [0060]; figures 1-11 -----	1-3,5-7,9
X,P	JP 2016 037306 A (DAINIPPON PRINTING CO LTD) 22 March 2016 (2016-03-22) the whole document -----	1,2,4,8
A	CA 904 804 A (PARR S PRINT AND LITHO LTD) 11 July 1972 (1972-07-11) the whole document -----	11
A	EP 2 028 130 A1 (ANDERSON PACKAGING INC [US]) 25 February 2009 (2009-02-25) paragraph [0032]; figure 3 -----	3
A	WO 2005/028316 A2 (COPE ALLMAN PLASTIC PACKAGING [GB]; HOWE NICHOLAS JAMES [GB]; MOULTON) 31 March 2005 (2005-03-31) the whole document -----	1,7
A	US 2009/045078 A1 (GELARDI JOHN [US] ET AL) 19 February 2009 (2009-02-19) paragraph [0087]; figure 24 -----	1,7

INTERNATIONAL SEARCH REPORT

Information on patent family members

International application No PCT/IB2017/051347

Patent document cited in search report	Publication date	Patent family member(s)	Publication date
GB 2451850	A	18-02-2009	NONE

US 7959005	B2	14-06-2011	DE 102007015090 A1 02-10-2008 EP 2142445 A1 13-01-2010 US 2010140132 A1 10-06-2010 WO 2008119602 A1 09-10-2008

WO 9965787	A1	23-12-1999	NONE

WO 2012112538	A1	23-08-2012	NONE

EP 3015390	A1	04-05-2016	EP 3015390 A1 04-05-2016 GB 2532006 A 11-05-2016 GB 2532116 A 11-05-2016 US 2016120748 A1 05-05-2016

JP 2016037306	A	22-03-2016	NONE

CA 904804	A	11-07-1972	NONE

EP 2028130	A1	25-02-2009	AT 512903 T 15-07-2011 EP 2028130 A1 25-02-2009 US 2009045096 A1 19-02-2009

WO 2005028316	A2	31-03-2005	AT 356050 T 15-03-2007 DE 602004005226 T2 08-11-2007 EP 1667921 A2 14-06-2006 WO 2005028316 A2 31-03-2005

US 2009045078	A1	19-02-2009	EP 2176140 A2 21-04-2010 JP 2010536667 A 02-12-2010 US 2009045078 A1 19-02-2009 WO 2009023717 A2 19-02-2009
