

(12) UK Patent Application (19) GB (11) 2482995 (13) A

(43) Date of A Publication

22.02.2012

(21) Application No: 1116281.5
(22) Date of Filing: 20.09.2011

(51) INT CL:
A41F 9/00 (2006.01) A41D 1/08 (2006.01)
A41D 7/00 (2006.01)

(71) Applicant(s):
Speedo International Limited
(Incorporated in the United Kingdom)
8 Manchester Square, London, W1 3PH,
United Kingdom

(56) Documents Cited:
GB 2273646 A GB 1392199 A
GB 0371911 A EP 1609832 A1
CA 002034722 A1 KR 200433543 Y1
US 5720041 A1 US 3920054 A1
US 3703008 A1 US 2106334 A1
US 20070266478 A1 US 20040019955 A1

(72) Inventor(s):
Tom Waller
Joseph Santry
Melanie Neal

(58) Field of Search:
INT CL A41B, A41D, A41F
Other: EPODOC WPI

(74) Agent and/or Address for Service:
Mewburn Ellis LLP
33 Gutter Lane, LONDON, EC2V 8AS, United Kingdom

(54) Title of the Invention: **Garment**
Abstract Title: **Garments having hems**

(57) A garment has a hem 2 defining an aperture 3 through which a portion of a wearer's body can pass, the hem including a resilient band (6, figure 8) encircling the aperture and having first (16) and second (17) edges wherein, in use, the tension in the first edge is greater than the tension in the second edge. The garment may be formed of textile material and may have an interior surface (4, figure 2) which, in use, contacts a wearer's body and an opposite exterior surface (5) on which the resilient band (6) is provided. The hem 2 may be a waist band and the garment may have a second hem 12 defining a second aperture, which is preferably a leg hole band. The garment may be a pair of swim jammers 1 or athletic shorts or leggings. Also disclosed is a garment formed of textile material and having a hem 12 defining an aperture through which a portion of a wearer's body can pass and formed by folding the textile material outwards from the aperture and securing onto an exterior surface (5, figure 5).

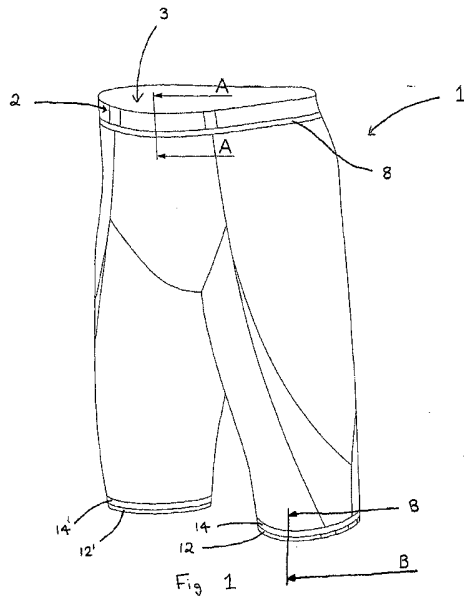

GB 2482995 A

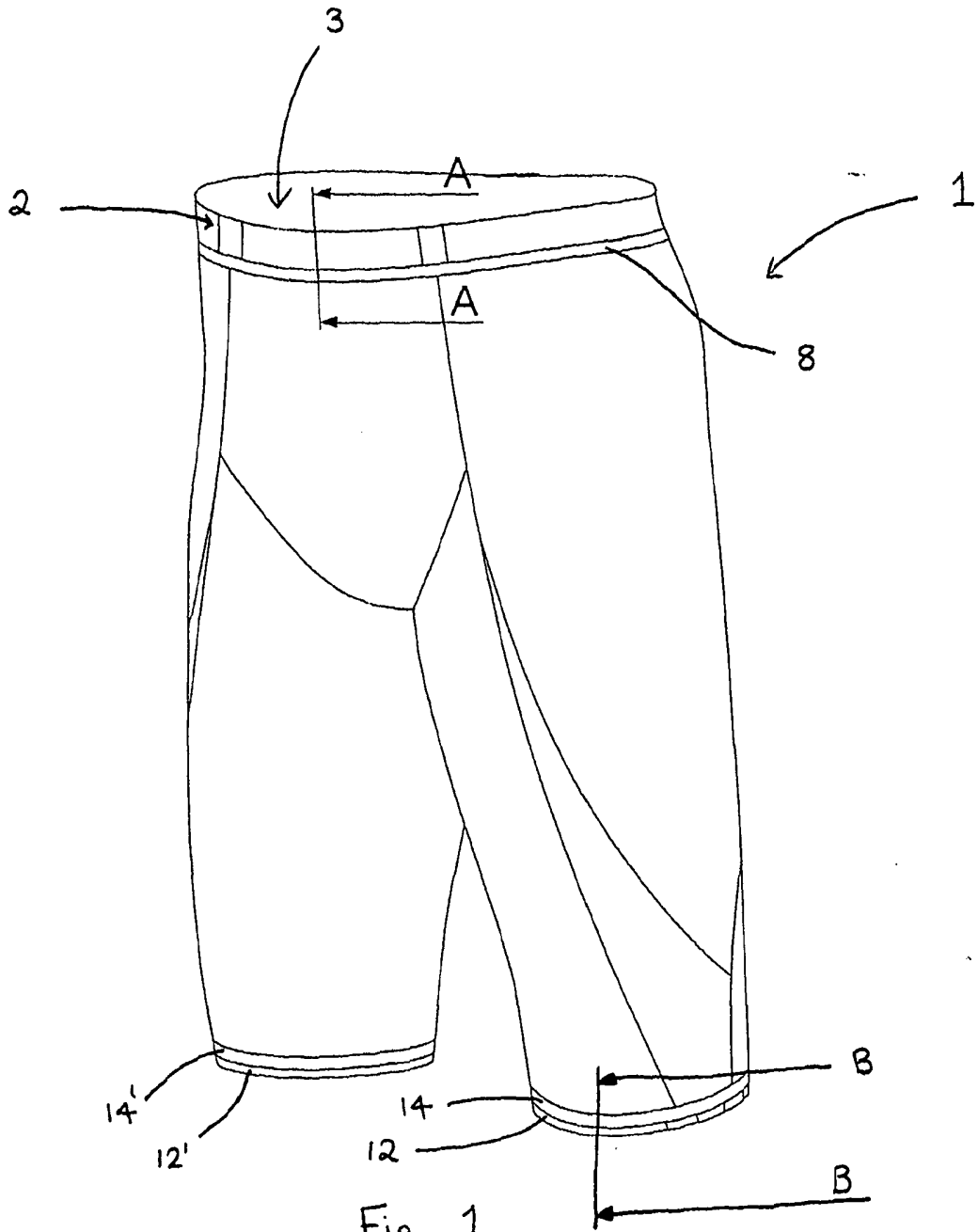

Fig 1

2 / 11

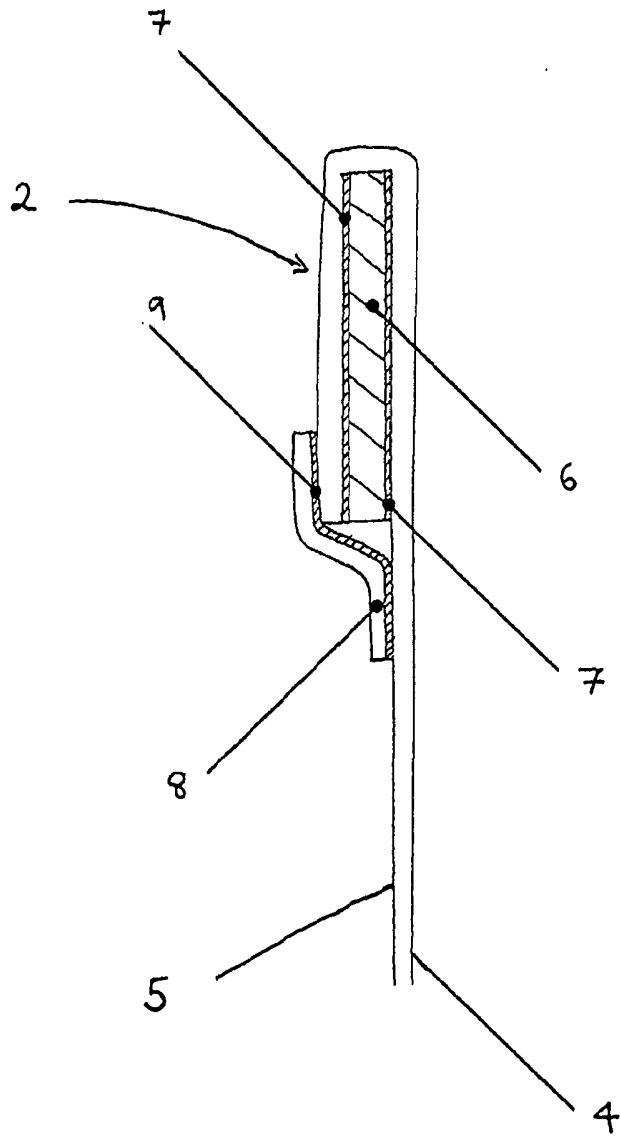

Fig 2

3/11

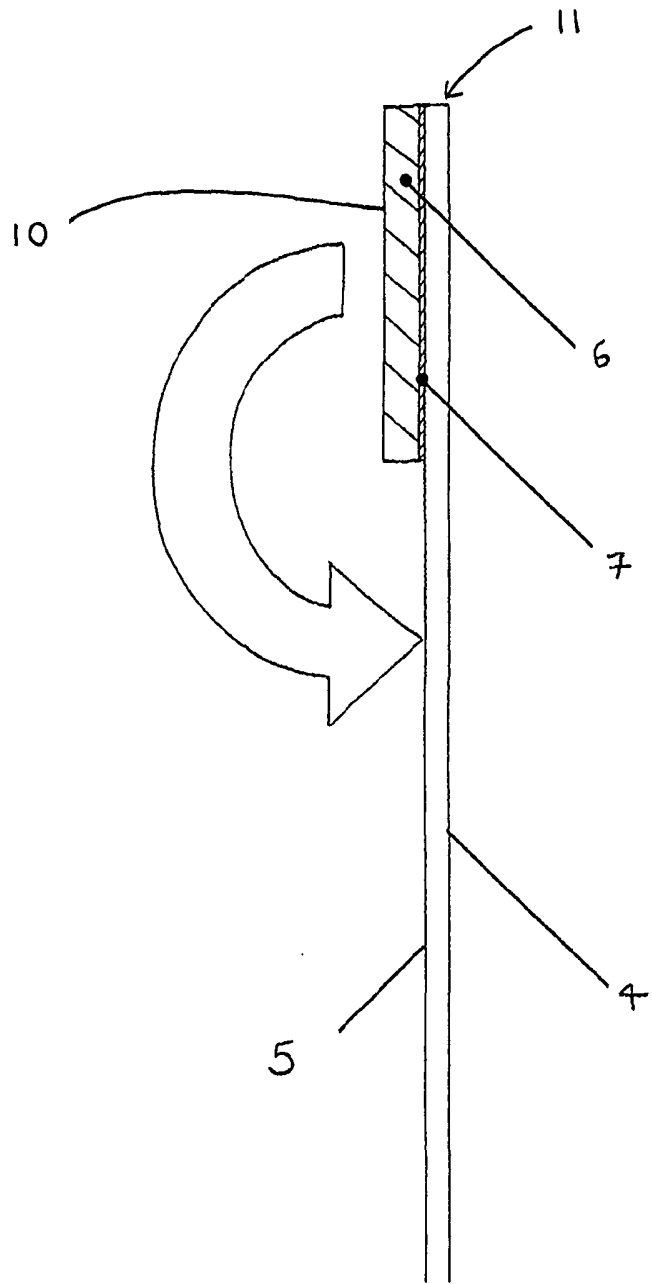

Fig 3

4 / 11

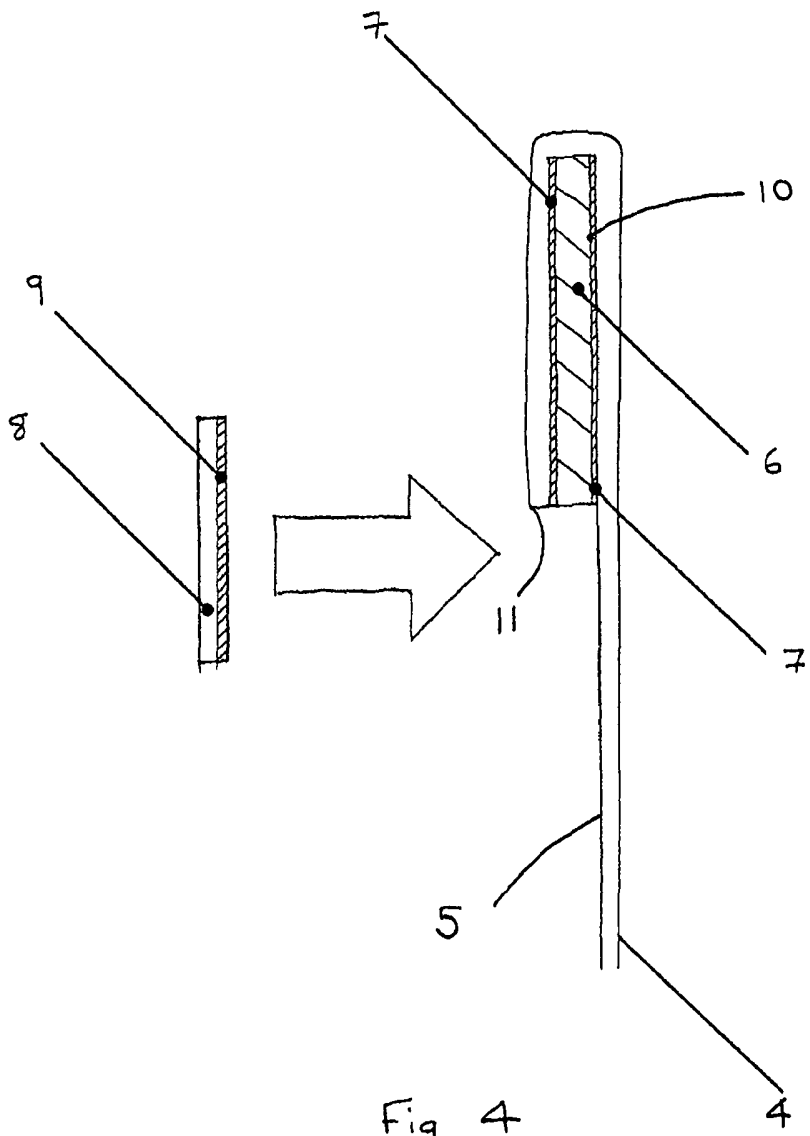

Fig 4

5/11

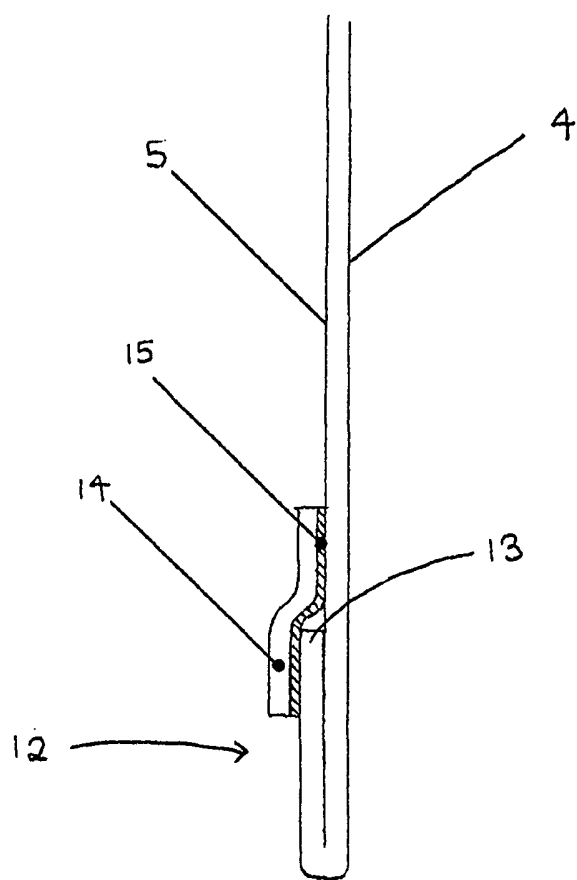

Fig 5

6/11

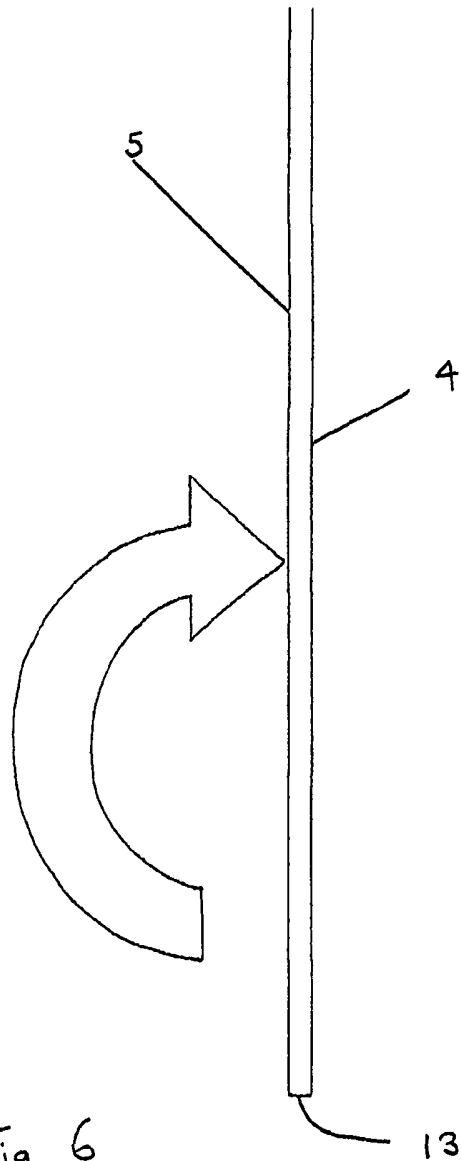

Fig 6

7 / 11

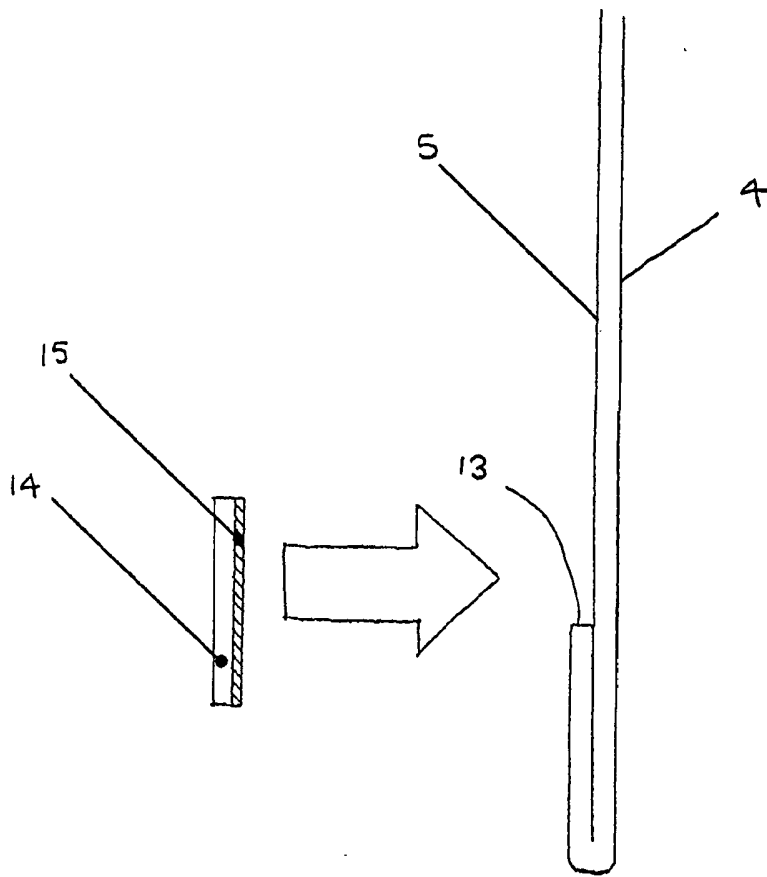
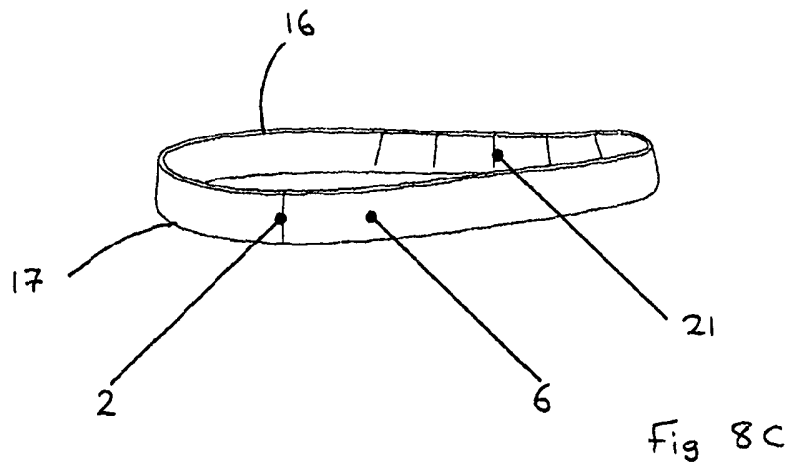
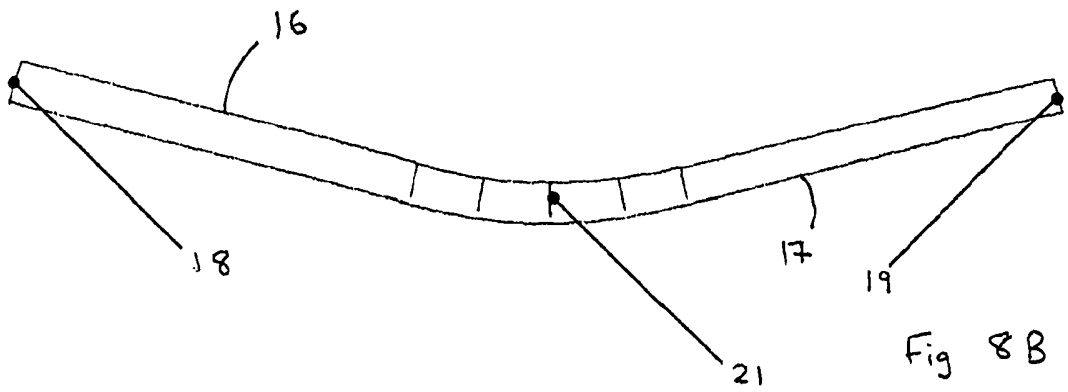
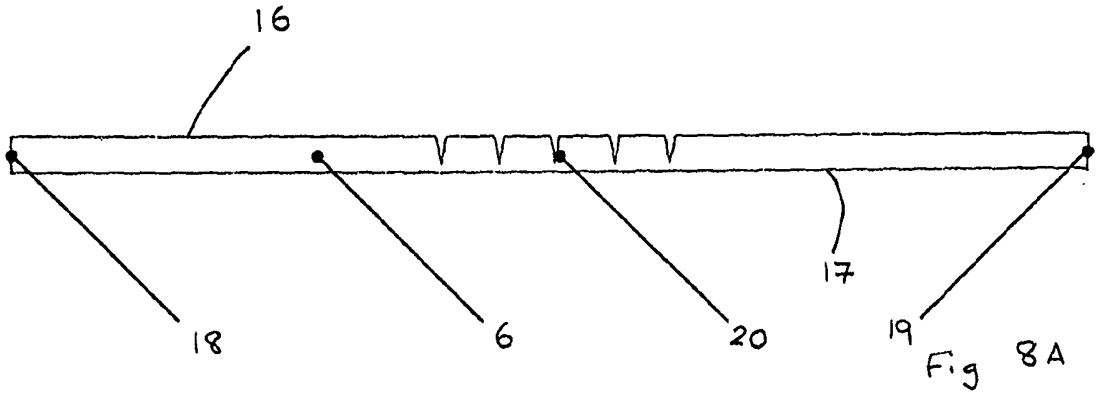

Fig 7



9/11

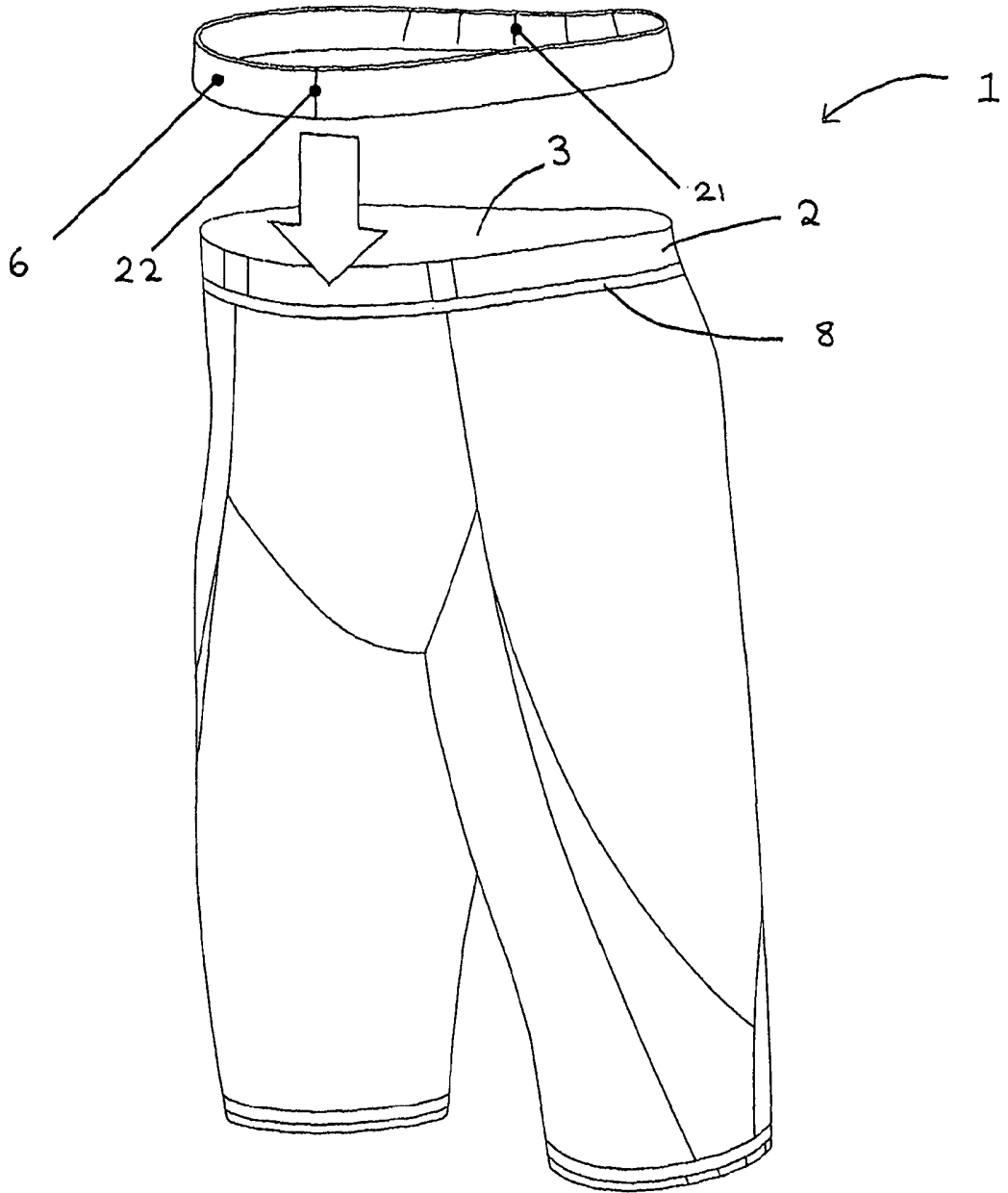

Fig 9

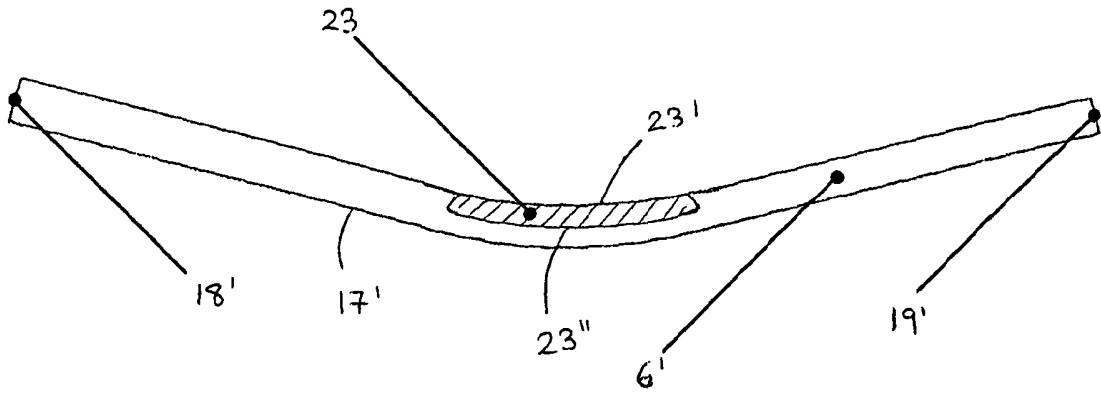

Fig 10A

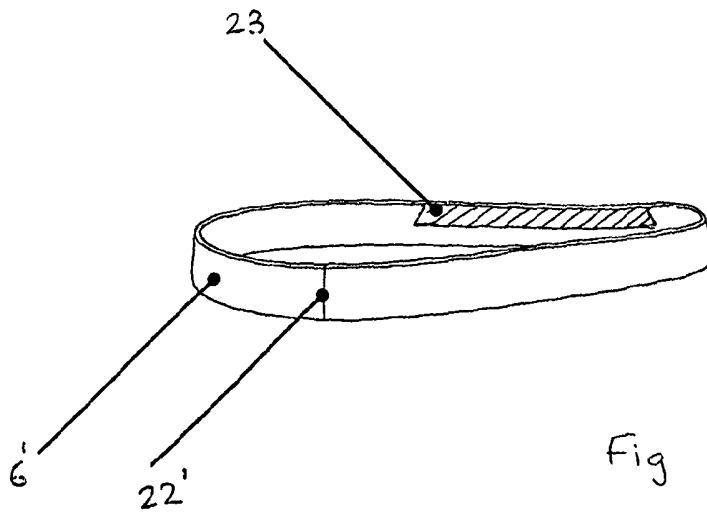

Fig 10B

11/11

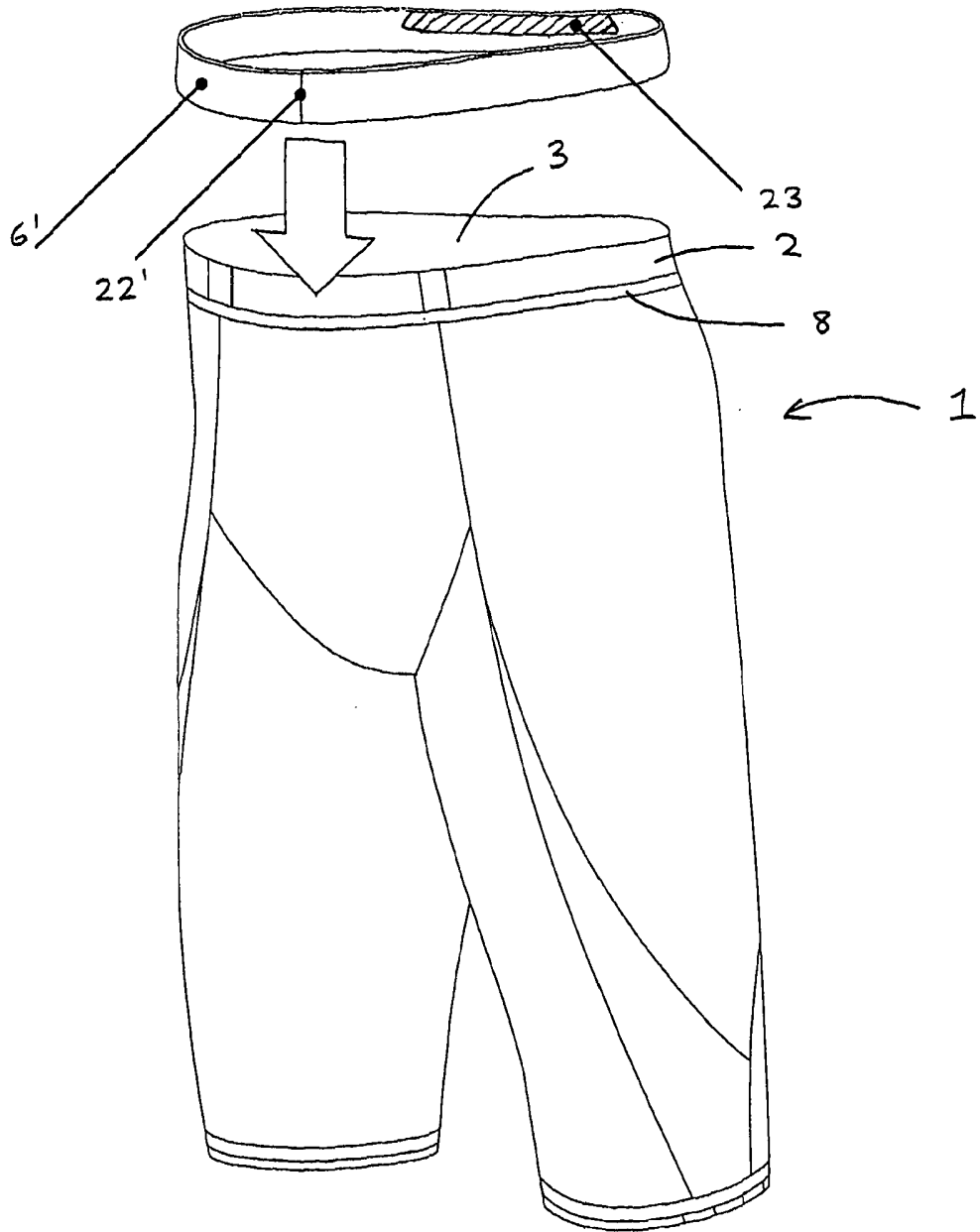
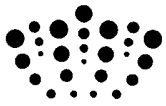

Fig 11



The following terms are registered trademarks and should be read as such wherever they occur in this document: Velcro

GARMENT

FIELD OF THE INVENTION

This invention relates to a garment. In particular, this invention relates to a garment having a hem defining an aperture through which a portion of a
5 wearer's body can pass (such as a waist band, leg hole band or arm hole band). Particular examples are described in relation to swim jammers, which is a preferred use. However, the invention can be applied to other sports and athletic garments including, for example, running shorts/leggings and track pants.

10

BACKGROUND

Most garments will include a hem (i.e. a border or edge) defining an aperture through which a portion of a wearer can pass to enable the wearer to insert their body into the garment. Such hems include waist bands, leg hole bands,
15 arm hole bands and neck hole bands.

In some garments such as sportswear, it is important that this hem fits tightly and securely against the wearer's body when in use to ensure that the garment remains comfortable and correctly fitted.

20

Some competitive sportsmen indulge in pre-race rituals which help them to prepare psychologically for a race. Male swimmers wearing jammers and athletes wearing leggings or shorts have been known to turn down their jammers/leggings/shorts at the waist band and then return the waist band to
25 its correct position just before racing. It is desirable to provide a waist band

which snaps into place from a folded down position to provide a more satisfying pre-race ritual and also to ensure that the waist band returns to its correct position.

5 For swimwear garments, the tight/secure fit is especially important for hems which present a leading edge (e.g. neck holes, arm holes and waist bands) as the swimmer wearing the garment moves through the water as these hems could scoop water and create unacceptable drag if they are not tightly fitted against a wearer's body. For this reason, it is known to include an elastic
10 band in such hems to ensure a tight fit which minimises drag caused by baggy hems.

There is, however, the possibility of such elasticated hems folding over onto themselves as the wearer moves through the water. This could be
15 uncomfortable and distracting for the swimmer.

Accordingly, an aim of the present invention is to provide a garment which has a hem which can be snapped into place from a folded down position, which has a good fit, and which, preferably, does not inadvertently fold over onto
20 itself.

Garments known as board shorts are also known and typically used for surfing or general (non-competitive) swimming wear. These types of garments have far less stringent requirements regarding water resistance and avoidance of
25 water scooping and so these board shorts do not generally have a tight-fitting,

elasticated waist band but, instead, have a more rigid waist band with a fly opening often secured with Velcro and a lace-up tie. The Velcro and lace-up ties can be fiddly, uncomfortable and potentially unreliable, especially in choppy open waters. A more simple, comfortable and secure solution is
5 required.

Accordingly, it is a further aim of the present invention to provide garment having a waistband which is comfortable and secure.

10 SUMMARY OF THE INVENTION

Accordingly, in a first aspect, the present invention provides a garment having a hem (i.e. an edge or border) defining an aperture through which a portion of a wearer's body can pass, the hem including a resilient band encircling the aperture and having a first edge and a second edge, wherein, in use, tension
15 in the first edge is greater than the tension in the second edge.

By providing a garment including a hem having a resilient band with a tension differential between the two edges of the band, it is possible to provide a secure and comfortably fitting hem, the tension differential allowing positioning
20 of the tighter first edge in a position on the wearer's body where a balance between comfort and a tight, secure fit can be obtained. For example, board shorts may be provided with such a hem as a waist band with the tighter edge of the resilient band located distal the aperture so that the shorts are secured to the body just above the hips thus avoiding excess tension about the more
25 sensitive stomach area.

Preferably the first edge is proximal the aperture and the second edge is distal the aperture.

- 5 Providing a hem having a resilient (elastic) band which has a first edge adjacent the aperture which, in use, is under a greater tension than a second edge distal the aperture helps bias the hem into the body adjacent the aperture thus maintaining a tight fit against the body ensuring a correct and secure fit is obtained. It also helps prevent the hem inadvertently flipping over
10 e.g. when the hem is a leading edge on a swim suit or jammers.

When the hem is folded over as part of a pre-race ritual, the tighter first edge is stretched (because it will typically be relocated to a broader body part e.g. the hips for a waistband hem) such that, when the hem is unfolded, it snaps
15 back into place driven by the potential energy stored in the stretched first edge. This snapping into place provides a satisfying pre-race ritual for the swimmer/athlete.

Preferably, the circumference (encircling the aperture) defined by the first
20 edge is shorter than the circumference defined by the second edge i.e. the resilient band has a shorter first edge than second edge.

This helps provide the tension differential between the edges.

In order to reduce the length of the first edge so that it is shorter than the length of the second edge, the hem can include a conventional resilient band having at least one dart included in the first edge. Preferably, a plurality of darts is included in the first edge. These darts may be distributed along the first edge e.g. uniformly around the circumference of the aperture or they may be grouped. More preferably the darts are grouped together in an area which, in use, is located at the rear of the wearer's body. Most preferably, the darts are provided exclusively together in an area which, in use, is located at the rear of the wearer's body. This is especially advantageous where the hem is a waist band and the darts are grouped together at the base of the wearer's back as this helps the garment conform to the shape of the wearer's body.

Each dart is preferably formed by cutting out a triangular section of the resilient band at the first edge and then securing the cut edges together e.g. by stitching or bonding. This helps avoid bulk at the hem.

In alternative embodiments, the resilient band is at least partly woven from elastic threads and the tension of the elastic threads parallel to the edges of the resilient band is greater at the first edge than at the second edge. Furthermore, the length of the elastic threads parallel to the edges of the resilient band is shorter at the first edge than at the second edge.

To achieve this, the resilient band is at least partly woven from elastic thread using differing feed speeds for the elastic thread and/or using a varying weaving pattern in order to create differing tension and lengths at the

opposing first and second edges. For example, the resilient band can be woven using an elastomeric weft thread (e.g. polyester). By increasing the elastic weft feed speed (i.e. the speed at which the weft thread is laid across the warp thread (e.g. nylon)) at the second edge, a longer length edge under
5 lower tension is obtained. By decreasing the elastic weft feed speed at the first edge, a shorter edge under a greater tension is obtained.

Additionally or alternatively, the tension under which the elastic weft thread (e.g. polyester) is laid across the warp thread (e.g. nylon) can be varied by
10 varying the weaving pattern. For example, weaving an elastic weft thread under every other warp thread will produce a tighter weave (and thus a shorter first edge) than weaving the weft thread under two or more warp threads at a time (at the longer second edge). Further details of these methods can be found in WO2010/043868.

15

The entire resilient band can be woven in a manner that results in one edge being shorter and having greater tension than the other edge (e.g. as described above) or only a portion may be woven in such manner. In the case where only a portion of the resilient band is woven in such manner, the
20 remainder of the resilient band can be integral with the portion (but woven so that there is no tension differential) or a portion can be spliced into a conventional resilient band (in such a manner that the first edge of the band remains shorter than the second edge). Preferably the portion/splice is provided in an area which, in use, is located at the rear of the wearer's body.
25 This is especially advantageous where the hem is a waist band and the

portion/splice is provided at the base of the wearer's back as this helps the garment conform to the shape of the wearer's body.

5 Preferably, the hem is a waist band. This provides a hem which can be folded down at the waist and then snapped back into position e.g. by a swimmer as part of a pre-race ritual. In this case, the first edge of the resilient band is located vertically above the second edge when the garment is in position on the wearer's body.

10 Preferably, the garment (which may be formed of a textile material (such as Lycra®/nylon)) has an interior surface which, in use contacts the wearer's body and an opposite exterior surface. Preferably, the resilient band is provided on the exterior surface. The resilient band may be secured to the exterior surface e.g. using adhesive.

15

Preferably, the resilient band is enclosed within an annular pocket created by folding the textile material forming the garment outwards from the aperture. Enclosing the resilient band provides protection for the resilient band and also gives the garment an improved aesthetic appeal. The resilient band may be
20 secured within the annular pocket at one or both of its faces using, for example, adhesive. The folded textile material is then secured to the exterior surface e.g. using bonded tape. Bonded tape helps maintain a low profile of the hem thus reducing drag.

This (i.e. folding the textile material outwards and securing it to the exterior surface) is termed "reverse hemming" since normal garment construction typically folds the textile material inwards and secures it to the interior surface so that the seam (which may be stitching or may be bonded tape) is hidden.

5 Hiding the seam has been previously considered important in sportswear such as swimwear as the seam induces frictional resistance and drag as the wearer moves through the water.

Reverse hemming is used in the preferred embodiments of the present
10 invention because it further biases the hem in towards the wearer's body thus ensuring a secure fit against the wearer's body and reducing the chances that the hem inadvertently folds down on itself.

In the most preferred embodiments, the hem is a waist band, and the garment
15 has a second hem defining a second aperture through which a portion of the wearer's body can pass, the second hem being formed by folding the textile material outwards from the second aperture and securing the textile material onto the exterior surface. Again, this second hem is "reverse hemmed" which biases it into the body as discussed above. The second hem may be a leg
20 hole band.

In a second aspect, the present invention provides a garment formed of textile material and having a hem (i.e. an edge or border) defining an aperture through which a portion of a wearer's body can pass, the garment having an
25 interior surface which, in use, contacts a wearer's body and an opposite

exterior surface, the hem being formed by folding the textile material outwards from the aperture and securing the textile material onto the exterior surface.

This (i.e. folding the textile material outwards and securing it to the exterior surface) is termed "reverse hemming" since normal garment construction typically folds the textile material inwards and secures it to the interior surface so that the seam (which may be stitching or may be bonded tape) is hidden. Hiding the seam has been previously considered important in sportswear such as swimwear as the seam induces frictional resistance and drag as the wearer moves through the water.

Reverse hemming is used in the second aspect of the present invention because it biases the hem in towards the wearer's body thus ensuring a secure fit against the wearer's body and reducing the chances that the hem inadvertently folds down on itself which, as described above, can be uncomfortable and distracting.

Preferably, the textile material is secured onto the exterior surface using a bonded tape. This helps maintain a low profile of the hem thus reducing drag.

The aperture with reverse hemming is preferably a waist band, leg hole band and/or arm hole band. Preferably, the garment includes reverse hemming at both the waist band and the leg hole band. Most preferably, the garment (which may be jammers or athletic shorts/leggings) includes a waist band

according to the first aspect and leg hole bands according to the second aspect.

Preferred embodiments of the present invention will now be described with
5 reference to the accompanying Figures in which:

BRIEF DESCRIPTION OF THE DRAWINGS

Figure 1 is a front view of a first embodiment of the present invention;

Figure 2 is a section through line A-A shown in Figure 1;

10 Figure 3 shows a first step in the construction of the waist band of the first embodiment;

Figure 4 shows a second step in the construction of the waist band of the first embodiment;

Figure 5 is a section through line B-B shown in Figure 1;

15 Figure 6 shows a first step in the construction of the leg hole band of the first embodiment;

Figure 7 shows a second step in the construction of the leg hole band of the first embodiment;

20 Figures 8A-8C show an isolated view of the resilient band of the first embodiment;

Figure 9 shows the orientation of the resilient band shown in Figure 8C in the first embodiment;

Figures 10A-10B show an isolated view of an alternative resilient band; and

25 Figure 11 shows the orientation of the alternative resilient band shown in Figure 10B in the first embodiment.

DETAILED DESCRIPTION OF THE INVENTION

Figure 1 shows a first embodiment of the present invention which is a pair of swim jammers 1 having a hem 2 which defines an aperture 3 through which the wearer's body can pass in order to allow the wearer's to fit the garment to their body.

The hem 2 is a waist band which encircles the aperture 3 and, when in use, encircles the wearer's waist.

10

Figure 2 shows a cross section through the line A-A. The jammers are formed of a textile material (e.g. a mix of nylon/Lycra®) having an interior surface 4 which, in use, contacts the wearer's body and an opposite exterior surface 5. It can be seen that the waistband hem 2 comprises a resilient band 6 which is enclosed within an annular pocket formed by the textile material forming the jammers. The resilient band is secured within the pocket using adhesive 7. A bonded tape 8 which includes an adhesive layer 9 secures the textile material onto the exterior surface.

20 Figures 3 and 4 show the construction of the waistband hem 2. In a first step shown in Figure 3, the resilient band is provided on the exterior surface 5 and secured to the exterior surface using adhesive. The textile material is folded outwards away from the aperture so that the exposed surface of the 10 of the resilient band abuts the exterior surface of the garment where is secured,

again using adhesive 7 as shown in Figure 4. This forms a pocket housing the resilient band.

Although Figure 3 shows the positioning of the resilient band 6 at the
5 extremity 11 of the textile material forming the garment and then a folding of the textile material carrying the resilient band 6, the resilient band 6 could be provided on the exterior surface 6 spaced from the extremity of the textile material and then the extremity 11 of the textile material folded over away from the aperture to enclose the resilient band 6. This would result in the
10 same arrangement as that shown in Figure 4.

Figure 4 shows the addition of a bonded tape to secure the extremity 11 of the textile material to the exterior surface 5. Use of such a bonded tape reduces the bulk of the waist band and thus helps reduce drag when the jammers are
15 used for swimming.

The steps shown in Figures 3 and 4 are termed reverse hemming since normal garment construction (especially swimwear construction) typically involves folding the textile material inwards into the aperture (so that the seam
20 is hidden inside the garment). Reverse hemming is useful in obtaining a secure fit of the waist band and in preventing the inadvertent flipping down of the waistband hem as it biases the hem in towards the wearer's body.

Figure 5 shows a cross section through the line B-B. This is a section through
25 a second hem which is a leg hole band 12 which defines an aperture through

which the wearer can insert their leg. The leg hole band hem 12 encircles the aperture and, when in use, encircles the wearer's thigh just above the knee.

It can be seen that the leg hole band hem 12 is formed of a double layer of textile material formed by folding. The lower extremity 13 of the textile material 13 is secured to the exterior surface 5 using a second bonded tape 14 which includes a second adhesive layer 15.

Figures 6 and 7 show the construction of the leg hole band hem 12. In a first step shown in Figure 6, the textile material is folded outwards away from the aperture so that it abuts the exterior surface 5 of the garment.

Figure 7 shows the addition of a bonded tape 14 to secure the extremity 11 of the textile material to the exterior surface 5. Use of such a bonded tape reduces the bulk of the leg hole band and thus helps reduce drag when the jammers are used for swimming.

The steps shown in Figures 6 and 7 are termed reverse hemming and, as discussed above in relation to the waist band hem, this biases the hem in towards the wearer's body creating a secure fit.

Although a single leg hole band is discussed above, the second leg hole band hem 12' is constructed in the same way as leg hole band hem 12.

Figures 8A-8C show isolated views of a first resilient band for use in the waistband hem 2 of first embodiment.

Figure 8A shows a resilient band having a first edge 16, a second edge 17, a first end 18 and a second end 19. The first edge 16 is provided with a number of triangular shaped cuts 20. The edges of these cuts are joined together as shown in Figure 8B to form a plurality of darts 21. This results in a resilient band having a first edge 16 which is longer than the second edge 17. The first and second ends 18, 19 are joined at a seam 22 as shown in Figure 8C to give a resilient band wherein the first edge 16 defines a smaller circumference than the second edge.

Figure 9 shows the orientation of the resilient band 6 in the waistband hem 2. The resilient band 6 is included in the waistband hem 2 with the first edge uppermost, the seam 22 positioned at the front of the garment and the darts positioned at the back of the garment. When the garment is worn, the seam will be located in the centre of the wearer's abdomen with the darts 21 being positioned in the small of the wearer's back. Having the darts in the small of the wearer's back helps the waistband hem to conform to the shape of the wearer's body.

Figure 10A shows an alternative resilient band 6' having a first edge 16', a second edge 17', a first end 18' and a second end 19'. The first edge 16' is shorter than the second edge 17'. This is achieved by providing a portion of resilient band woven from elastic weft thread (polyester) where the weft

speed feed is varied during manufacture. The elastic weft feed speed is increased at the uppermost edge of the portion 23' so that it has a longer length than the lowermost edge 23'' of the portion at which the elastic weft feed speed is decreased. This portion is spliced into a conventional resilient band such that the first edge of the band is shorter in length than the second. To achieve this, the space into which the portion is spliced must have at least an equal width on opposing circumferential sides (otherwise any reduction in length at the first edge (achieved by the reduction in length of the uppermost edge 23' of the portion 23) will be negated). The first and second ends 18', 19' are joined at a seam 22' as shown in Figure 10B to give a resilient band wherein the first edge 16' defines a smaller circumference than the second edge 17'.

Figure 11 shows the orientation of the resilient band 6' in the waistband hem 2. The resilient band 6' is included in the waistband hem 2 with first edge 16' uppermost, the seam 22' positioned at the front of the garment and the portion 23 positioned at the back of the garment. When the garment is worn, the seam will be located in the centre of the wearer's abdomen with the portion 23 being positioned in the small of the wearer's back. Having the portion 23 in the small of the wearer's back helps the waistband hem to conform to the shape of the wearer's body.

By providing a garment having a waistband hem including a resilient band which has a first edge which is shorter than its second edge and thus provides a smaller (and tighter) circumference around the wearer's waist than the

second edge, it is possible to provide a waist band hem which is securely fitted and which can be folded down and snapped back into place to provide a satisfying pre-race ritual.

5 The reverse hemming of the waistband hem and leg hole band hems biases the hems in towards the wearer's body and this also helps provide a secure fit and prevents inadvertent folding over of the hems when the garment is being worn.

10 The skilled person will appreciate that the jammers illustrated in the Figures and described above are examples embodying inventive concepts described herein and that many and various modifications can be made without departing from the invention.

15

20

CLAIMS

1. Garment having a hem defining an aperture through which a portion of a wearer's body can pass, the hem including a resilient band encircling the
5 aperture and having a first edge and a second edge wherein, in use, the tension in the first edge is greater than the tension in the second edge.
2. Garment according to claim 1 wherein the first edge is proximal the aperture and the second edge is distal the aperture.
- 10 3. Garment according to claim 1 or 2 wherein the circumference defined by the first edge is shorter than the circumference defined by the second edge.
- 15 4. Garment according to claim 3 wherein the first edge of the resilient band includes at least one dart to reduce its length.
5. Garment according to claim 4 wherein the first edge includes a plurality of darts.
- 20 6. Garment according to claim 5 wherein the plurality of darts is included exclusively in an area which, in use, is located at the rear of the wearer's body.

7. Garment according to claim 1, 2 or 3 wherein the resilient band is at least partly woven from elastic threads and wherein the tension of the elastic threads parallel to the edges of the resilient band is greater at the first edge than at the second edge.

5

8. Garment according to claim 7 wherein the resilient band is at least partly woven from elastic threads and wherein the length of the elastic threads parallel to the edges of the resilient band is shorter at the first edge than at the second edge.

10

9. Garment according to any one of the preceding claims wherein the hem is a waist band.

10. Garment according to any one of the preceding claims wherein the garment is formed of textile material and has an interior surface which, in use contacts the wearer's body and an opposite exterior surface and wherein the resilient band is provided on the exterior surface.

11. Garment according to claim 10 wherein the resilient band is enclosed within an annular pocket created by folding the textile material outwards away from the aperture and securing the textile material onto the exterior surface.

12. Garment according to claim 10 or 11 wherein the hem is a waist band, the garment having a second hem defining a second aperture through which a portion of the wearer's body can pass, the second hem being formed by

folding outwards from the second aperture and securing the textile material onto the exterior surface.

13. Garment according to claim 12 wherein the second hem is a leg hole
5 band.

14. Garment formed of textile material and having a hem defining an aperture through which a portion of a wearer's body can pass, the garment having an interior surface which, in use, contacts a wearer's body and an
10 opposite exterior surface, the hem being formed by folding the textile material outwards from the aperture and securing the textile material onto the exterior surface.

15. Garment according to claim 14 wherein the hem is a leg hole band.
15

16. Garment according to any one of claims 11 to 15 wherein the textile material is secured on the exterior surface using a bonded tape.

17. Garment according to any one of the preceding claims wherein the
20 garment is a sports wear garment.

18. Garment according to claim 17 wherein the sportswear garment is a pair of swim jammers or athletic shorts/leggings.

19. Garment substantially as any one embodiment herein described with reference to the accompanying figures.

Amendments to the claims have been filed as follows:

1. Swim jammers formed of textile material and having a hem defining an aperture through which a portion of a wearer's body can pass, the garment having an interior surface which, in use, contacts a wearer's body and an opposite exterior surface, the hem being formed by folding the textile material outwards from the aperture and securing the textile material onto the exterior surface.

2. Swim jammers according to claim 1 wherein the hem is a leg hole band.

3. Swim jammers according to claim 1 wherein the hem is a waistband.

4. Swim jammers according to claim 3 further comprising a leg hole band defining a second aperture through which a portion of a wearer's body can pass, the leg hole band being formed by folding the textile material outwards from the second aperture and securing the textile material onto the exterior surface.

5. Swim jammers according to claim 3 or 4 wherein the waist band includes a resilient band encircling the aperture and having a first edge and a second edge wherein, in use, the tension in the first edge is greater than the tension in the second edge.

25

6. Garment according to claim 5 wherein the first edge is proximal the aperture and the second edge is distal the aperture.

7. Garment according to claim 5 or 6 wherein the circumference defined by the first edge is shorter than the circumference defined by the second edge.

8. Garment according to claim 7 wherein the first edge of the resilient band includes at least one dart to reduce its length.

10

9. Garment according to claim 8 wherein the first edge includes a plurality of darts.

10. Garment according to claim 9 wherein the plurality of darts is included exclusively in an area which, in use, is located at the rear of the wearer's body.

15

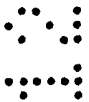

11. Garment according to claim 5, 6 or 7 wherein the resilient band is at least partly woven from elastic threads and wherein the tension of the elastic threads parallel to the edges of the resilient band is greater at the first edge than at the second edge.

20



12. Garment according to claim 11 wherein the resilient band is at least partly woven from elastic threads and wherein the length of the elastic threads

parallel to the edges of the resilient band is shorter at the first edge than at the second edge.

13. Garment according to any one of claims 5 to 12 wherein the resilient
5 band is enclosed within an annular pocket created by folding the textile material outwards away from the aperture and securing the textile material onto the exterior surface.

14. Swim jammers according to any one of claims 1 to 13 wherein the
10 textile material is secured on the exterior surface using a bonded tape.

15. Garment substantially as any one embodiment herein described with reference to the accompanying figures.

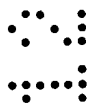

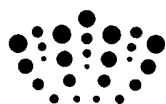

Application No: GB1116281.5
Claims searched: 1 - 13 and 16 - 18

Examiner: Dr Karen Payne
Date of search: 21 November 2011

Patents Act 1977: Search Report under Section 17

Documents considered to be relevant:

Category	Relevant to claims	Identity of document and passage or figure of particular relevance
X	1 - 6, 9	GB 0371911 A (STEIN) See page 4 and figure 2.
X	1 - 3, 7 - 11, 16 - 18	US 2004/0019955 A1 (MORRIS et al.) See pages 2 & 3 and figures 1 - 3.
X	1 - 3, 7 - 9, 17, 18	US 2106334 A1 (ADAMSON) See page 2 and figures 2 & 3.
X	1 - 3, 7 - 9	US 3920054 A1 (GOFF, JR et al.) See columns 1 & 2 and figures 1, 2 & 4.
X	1 - 3, 7, 8, 17, 18	GB 2273646 A (WACOAL CORP) See pages 13 - 17 and figure 1.
X	1 - 3, 9, 17, 18	US 3703008 A1 (HUDSON) See column 2 and figures 1 - 6.

Categories:

X	Document indicating lack of novelty or inventive step	A	Document indicating technological background and/or state of the art.
Y	Document indicating lack of inventive step if combined with one or more other documents of same category.	P	Document published on or after the declared priority date but before the filing date of this invention.
&	Member of the same patent family	E	Patent document published on or after, but with priority date earlier than, the filing date of this application.

Field of Search:

Search of GB, EP, WO & US patent documents classified in the following areas of the UKC^X :

Worldwide search of patent documents classified in the following areas of the IPC

A41D; A41F

The following online and other databases have been used in the preparation of this search report

EPODOC, WPI

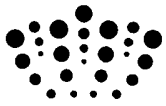

International Classification:

Subclass	Subgroup	Valid From
A41F	0009/00	01/01/2006
A41D	0001/08	01/01/2006
A41D	0007/00	01/01/2006

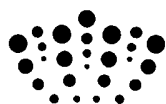

Application No: GB1116281.5

Examiner: Dr Karen Payne

Claims searched: 14 - 18

Date of search: 20 December 2011

Patents Act 1977
Further Search Report under Section 17

Documents considered to be relevant:

Category	Relevant to claims	Identity of document and passage or figure of particular relevance
X,Y	X: 14, 15, 17, 18; Y: 16	US 5720041 A1 (INZER) See column 4 and figure 2.
X,Y	X: 14, 15; Y: 16	CA 2034722 A1 (ZITMANIS) See page 4 and figures 2 & 3.
X,Y	X: 14, 15; Y: 16	KR 200433543 Y1 (KIM) 11.12.06 See figures.
X	14 - 16	US 2007/0266478 A1 (GIROD) See page 2 and figure 1.
X	14, 17, 18	GB 1392199 A (UMBRO INTERNATIONAL) See page 2 and figures 3 & 4.
Y	16	EP 1609832 A1 (VAN DE VELDE) See pages 4 & 6 and figures 1, 2 & 4.

Categories:

X	Document indicating lack of novelty or inventive step	A	Document indicating technological background and/or state of the art.
Y	Document indicating lack of inventive step if combined with one or more other documents of same category.	P	Document published on or after the declared priority date but before the filing date of this invention.
&	Member of the same patent family	E	Patent document published on or after, but with priority date earlier than, the filing date of this application.

Field of Search:

Search of GB, EP, WO & US patent documents classified in the following areas of the UKC^X :

Worldwide search of patent documents classified in the following areas of the IPC

A41B; A41D; A41F

The following online and other databases have been used in the preparation of this search report

EPODOC, WPI

International Classification:

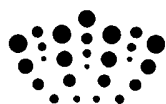

Subclass	Subgroup	Valid From
A41F	0009/00	01/01/2006
A41D	0001/08	01/01/2006
A41D	0007/00	01/01/2006