

G. H. LAUB.
SLEIGH.

No. 192,518.

Patented June 26, 1877.

Fig 1

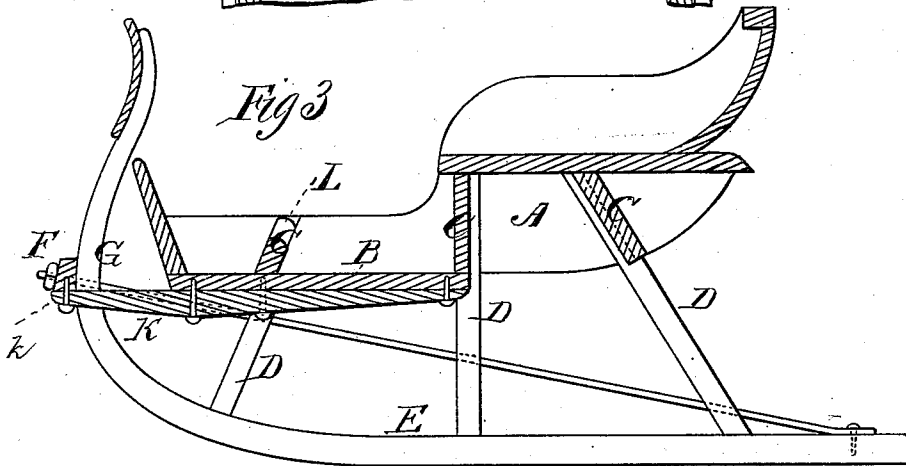
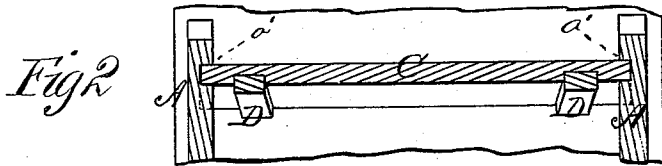
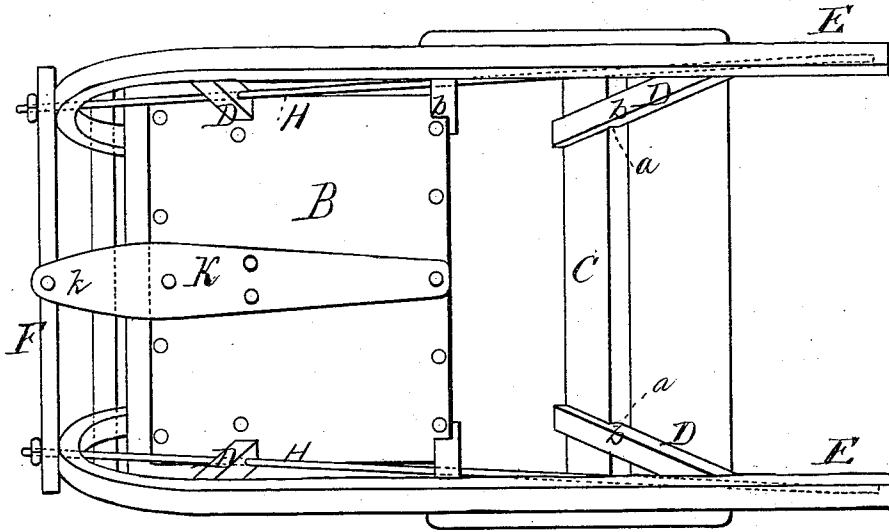

WITNESSES
Villette Anderson
F. J. Chasi

INVENTOR
George H. Laub,
by *E. W. Anderson,*
ATTORNEY

UNITED STATES PATENT OFFICE.

GEORGE H. LAUB, OF WEST LEBANON, INDIANA.

IMPROVEMENT IN SLEIGHS.

Specification forming part of Letters Patent No. 192,518, dated June 26, 1877; application filed October 21, 1876.

To all whom it may concern:

Be it known that I, GEORGE H. LAUB, of West Lebanon, in the county of Warren and State of Indiana, have invented a new and valuable Improvement in Sleighs; and I do hereby declare that the following is a full, clear, and exact description of the construction and operation of the same, reference being had to the annexed drawings, making a part of this specification, and to the letters and figures of reference marked thereon.

Figure 1 of the drawings is a representation of a bottom view of my improved sleigh. Fig. 2 is a vertical cross-sectional view of the same, and Fig. 3 is a longitudinal vertical sectional view thereof.

This invention has relation to sleighs; and it consists in the construction and novel arrangement of the wide braces or transverse timbers connecting the side-boards of the body; the long knees secured to the ends of these transverse timbers; the oblique brace-rods running from the heels of the runners to the cross-bar in front of the bends; and the central stay extended in front from under the body to the cross-bar above mentioned, as hereinafter shown and described.

In the accompanying drawings, the letter A represents the sides, and B the bottom, of the body of a sleigh, which may be of any usual pattern. C represents the braces or transverse timbers of the body, to which the sides A are attached, the latter being usually grooved, as shown at *a'*, Fig. 2, for the reception of the ends of the former. These timbers are made deep from their upper to their lower edges, and are designed to be arranged under the seat or seats as far as practicable in the construction, although, if necessary, they may be extended across above the bottom, as illustrated in the front portion of the sleigh shown in the drawings. D represents the knees of the sleigh, extending to the runners E. These knees are bolted to the braces at or near the ends of the latter. The ends of the knees extend upward across the braces, and are usually let into grooves, as shown at *a*. Hence the knees are firmly secured to said braces, the lower edges of which

usually rest on shoulders *b* of the knees. F indicates the cross-bar in front of the bends G of the runners, at or a little above the level of the bottom of the sleigh. This cross-bar is strongly secured to the runners by means of the long oblique brace or tie rods H, which extend from said cross-bar through the bends of the runners, and the successive knees to the heels of said runners, where they are firmly secured, as shown. The central portion of the cross-bar is supported by the projecting extension *k* of the central longitudinal stay K, which is secured to the bottom B of the body. This central stay is also designed to keep the runners steady, preventing them from giving way laterally.

When the transverse brace is arranged above the bottom boards, as shown at L in the drawings, it forms a convenient foot-rest, whereby the feet can be supported above the floor.

In this invention the bed of the body and the timbers of the running-gear are combined in a strong and compact manner.

What I claim as my invention, and desire to secure by Letters Patent, is—

1. The sides A of a sleigh-box transversely grooved at *a'* to receive the ends of the deep transverse braces C, in combination with the knees D, extending across the said braces let into grooves *a* formed therein, and rigidly secured thereto, and the inclined tie-rods H secured at their front ends to the runners, and extending through the said braces, substantially as specified.

2. The combination, with the runners E and the cross-bar in front of the bends thereof, of the oblique brace or tie rods running from said cross-bar through the successive knees D to the heels of said runners, substantially as specified.

In testimony that I claim the above I have hereunto subscribed my name in the presence of two witnesses.

GEORGE HARRISON LAUB.

Witnesses:

THOMAS MURPHY,
ED. L. STEWART.