

(No Model.)

W. SWEET.  
WASHING MACHINE.

No. 527,463.

Patented Oct. 16, 1894.

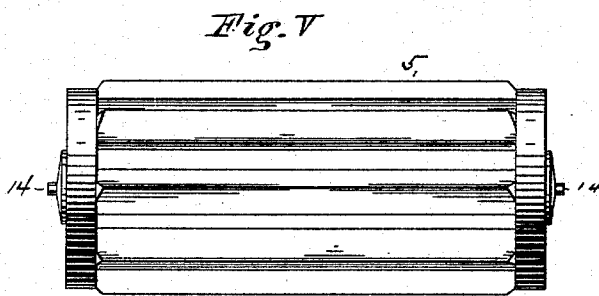
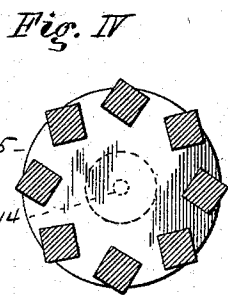
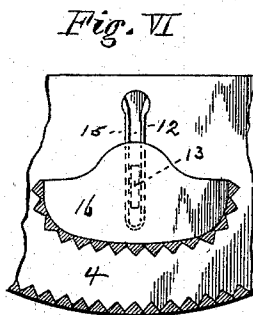
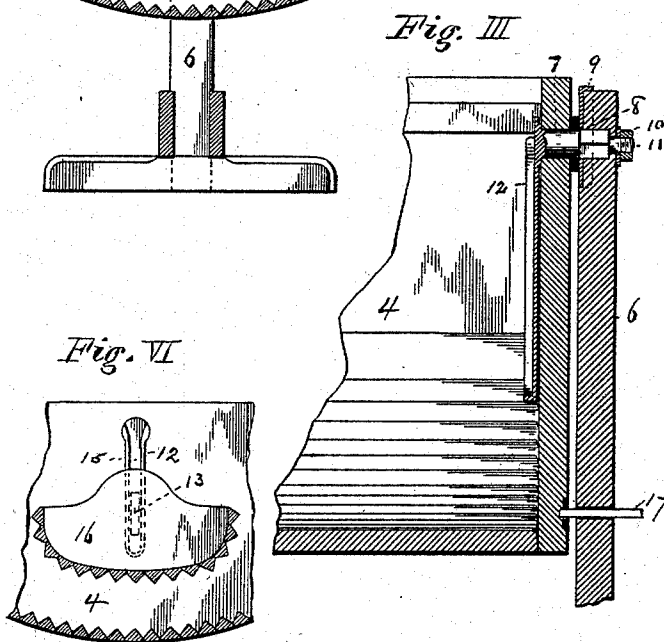
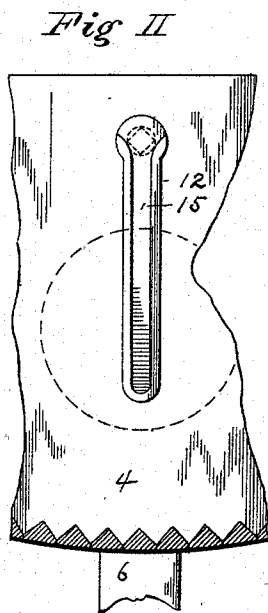
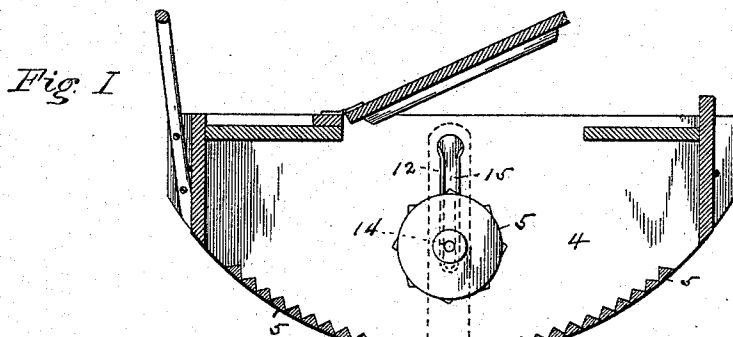

WITNESSES:  
W. B. Hulse  
E. C. Coolican.

Warren Sweet INVENTOR  
BY  
H. C. Hartman ATTORNEY.

# UNITED STATES PATENT OFFICE.

WARREN SWEET, OF FORT WAYNE, INDIANA, ASSIGNOR TO JOHN F. CURTICE, OF SAME PLACE.

## WASHING-MACHINE.

SPECIFICATION forming part of Letters Patent No. 527,463, dated October 16, 1894.

Application filed October 25, 1893. Serial No. 489,094. (No model.)

*To all whom it may concern:*

Be it known that I, WARREN SWEET, a citizen of the United States, residing at Fort Wayne, in the county of Allen, in the State of Indiana, have invented certain new and useful Improvements in Washing-Machines; and I do hereby declare that the following is a full, clear, and exact description of the invention, which will enable others skilled in the art to which it appertains to make and use the same, reference being had to the accompanying drawings, which form part of this specification.

My invention relates to improvements in washing machines known as rocking and swinging machines; and its objects are to provide an improved washing machine easily operated, economical in construction, and efficient in operation, and adapted to be easily dried and cleaned when not in use; and the invention consists in the construction and novel combination of parts hereinafter described, pointed out in the appended claims, and illustrated in the accompanying drawings, in which—

Figure 1 is a vertical section of a washing machine containing my improved devices. Fig. 2 is a side view of the vertical bar having a slideway inside the suds box, parts of which are broken away. Fig. 3 is a cross section of part of Fig. 1 showing the bar, horizontal shaft and connections to the standard. Fig. 4 is a cross section of the preferred form of rubber. Fig. 5 is a side elevation of Fig. 4, and Fig. 6 is a cross section of a different form of rubber.

Similar numerals of reference refer to similar parts throughout the views.

The suds box 4 is preferably provided with a curved bottom 5, and is mounted between two standards 6 on journals 7 formed on the horizontal metallic shafts 8, which shafts are secured rigidly to the standards 6 so that they will not turn or move. I prefer to secure the shafts 8 to the standard by making that portion of the shaft which passes through the standard rectangular in form, and adapt the opening in the standard through which it passes to such form; and also to make the journals 7 larger so as to afford shoulders to the rectangular part of the shaft 8, and also

secure metal plates 9 to the standards 6 having openings of like form to receive said rectangular parts. Then by placing a nut 10 on bolts 11 formed on the outer end of the shafts 8, and screwing them up tightly the shoulders are drawn firmly against the plates 9, and the shafts are held securely and rigidly to the standards. The inner end of the shaft 8 extends within the suds box 4 and is attached rigidly to the bar 12 or, as shown in Fig. 3 is formed in the same piece with the bar 12 which extends at right angles downward near to the bottom thereof.

The bars 12 are of any suitable form adapted to furnish slideways, whereby the rubber is held in such position that it has a vertical movement up and down in the suds box 4, but no backward or forward movement when the box is oscillated. The preferred form of the bar 12 is shown in Fig. 2. It is a flat metal bar to afford the requisite strength and rigidity, and is provided on the surface, facing the rubber 5, with a groove 15, in which the projections 13, or the journals 14 of the rubber 5, are confined so as to slide vertically.

Any suitable form of rubber may be used. One form Fig. 6, consists of end pieces 16, across the bottom of which slats are secured to form a corrugated bottom. Upon these end pieces projections 13 are attached adapted to move vertically in the groove 15. The whole is so constructed that the projections 13 may move freely up and down in the groove or slideway 15 of the bar 12 without other motion, thereby holding the rubber in the same vertical plane; but I prefer a rubber in form of a roller 5 held between the bars 12 by its journals 14 engaging the groove 15 of the bar 12, whereby the roller is adapted to move up and down according to the amount of clothes underneath it, and is oscillated or turned back and forth on its journals 14 by the oscillation of the box and the motion of the water and clothes. A pin 17 slides through the standards 6 into a recess in the suds box 4 to hold it in place when filling or emptying. The purpose of this construction is, to provide means so that the rubber shall move up and down to accommodate itself to the mass of clothing in the suds box and yet be held in same vertical plane, so that it cannot be

moved backward or forward by the oscillation of the suds box; and also to adapt it to the suds box, so that it can be closed by its lid during operation, thereby retaining the heat and steam. The combination of fixed slide bars 12 on the inner end of the horizontal shafts 8 permit of a variety of forms or means of adjusting the rubber to them, to perform the functions described.

10 The operation is readily understood from the above description. The parts being in place and clothing placed in the suds box with water, the oscillation of the suds box carries the clothes backward and forward under the rubber, which being held in position by the slide bars and slides and their connection with the standards, produces with such oscillation a rubbing action on the clothes, the rubber also moving up and down on the slides or slide bars to accommodate itself to the amount or inequalities of the mass of clothing. At the same time the oscillation of the suds box produces a dashing and flowing of the water in, around, and more or less through the clothing.

25 Having thus described my invention, what I claim as new, and desire to secure by Letters Patent, is—

1. The combination with a covered suds box, the frame upon which it is supported, of the removable rubber: shafts or journals rigidly attached to the frame on which the suds box hangs and is oscillated: vertically placed

bars having slideways extending throughout their length, in which the projecting ends of the rubber are free to turn to and fro and move vertically: the said bars being fixed to the ends of the said journals within the suds box below the plane of the cover, so that said suds box may be oscillated between said frame and said bars without moving either, substantially as and for the purpose set forth.

2. In a washing machine of the character described, the combination with the suds box its cover, and the frame to which it is hung for oscillation, of the journal shaft having a square portion fixed to the said frame, the rubber, the bars formed in the same piece with the said journal shaft and the square portion, located inside the suds box below the said cover, and means located at the side of the frame for securing the said square portion to the frame and holding the bars immovably in the same horizontal plane with the said frame, the said bars having slideways in which the rubber is free to turn to and fro and to slide vertically when the suds box is oscillated, substantially as set forth.

In testimony whereof I hereunto subscribe my name, in the presence of two witnesses, this 1st day of September, 1893.

WARREN SWEET.

Witnesses:

H. C. HARTMAN,  
E. C. COOLICAN.