



C. D. YOUNG.  
STOKER FEED MECHANISM.  
APPLICATION FILED NOV. 7, 1910.

1,000,658.

Patented Aug. 15, 1911.

2 SHEETS—SHEET 2.

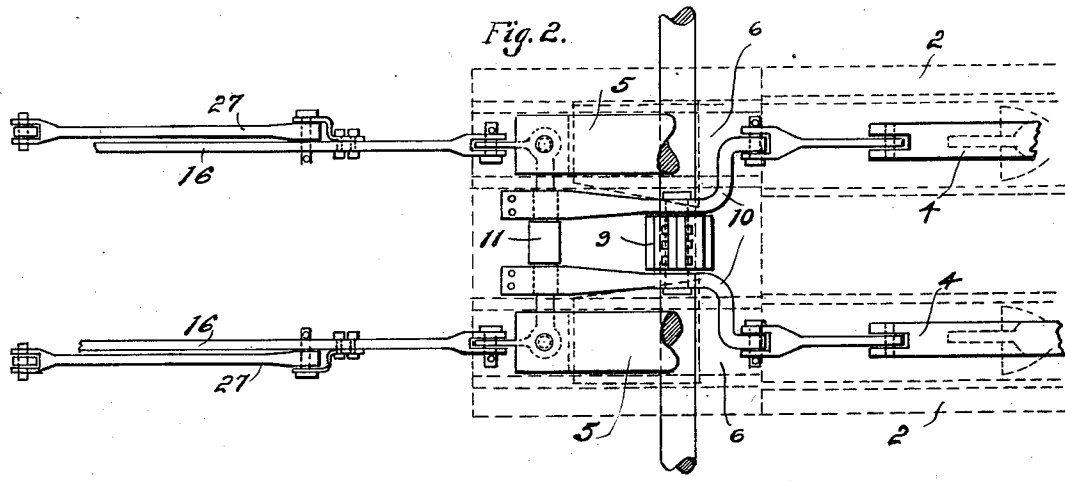
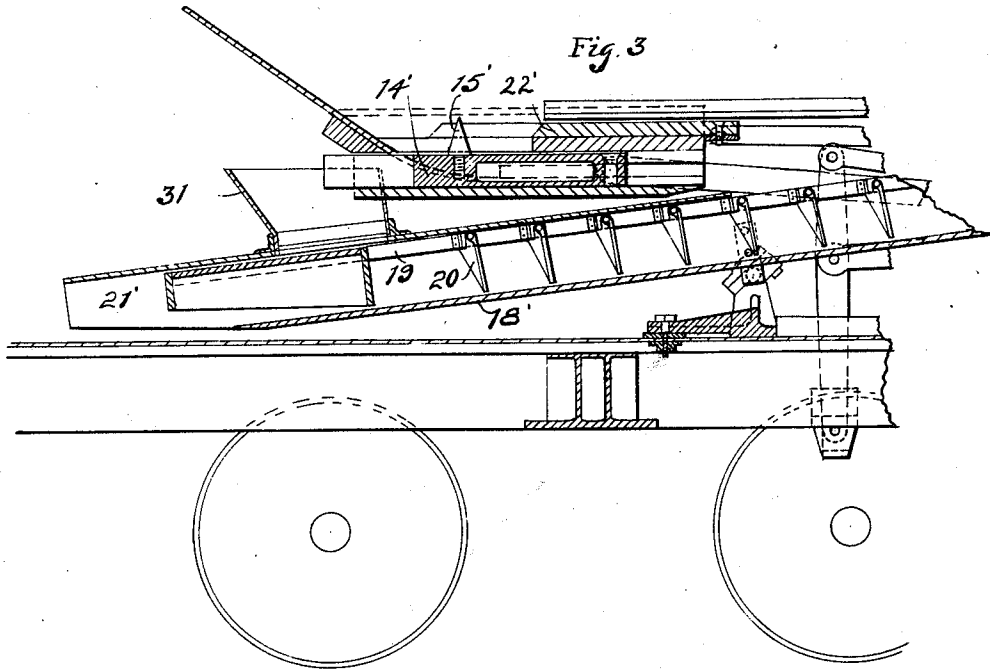

WITNESSES  
*Julian H. Hendig.*  
*L. A. Myers*

INVENTOR  
*Charles D. Young*  
by atty  
*Paul Symmesworth*

# UNITED STATES PATENT OFFICE.

CHARLES D. YOUNG, OF PITTSBURG, PENNSYLVANIA.

STOKER-FEED MECHANISM.

1,000,658.

Specification of Letters Patent. Patented Aug. 15, 1911.

Application filed November 7, 1910. Serial No. 591,148.

To all whom it may concern:

Be it known that I, CHARLES D. YOUNG, a citizen of the United States, residing at Pittsburg, in the county of Allegheny and State of Pennsylvania, have invented certain new and useful Improvements in Stoker-Feed Mechanism, of which the following is a specification.

The invention relates to feed mechanism for use with an automatic stoker of the underfeed type and is illustrated as applied to a locomotive, but it will be understood that certain features of the invention are capable of general application. The invention has for its primary objects; the provision of a simplified mechanism for carrying the coal from the tender to the feed pistons and one wherein no joints or connections are required in the transfer chute; the provision of an arrangement wherein the crushing of the coal and its transfer to the locomotive is divided into two stages and the effectiveness of the feed increased; and the provision of an improved and simplified link connection for driving the auxiliary feeding pistons in unison with the main feed pistons. Certain embodiments of the invention are illustrated in the accompanying drawings, wherein:—

Figure 1 is a longitudinal section through a locomotive tender provided with my improved construction.

Figure 2 is a diagrammatic plan view of the operating link mechanism employed, with the location of certain other cooperating parts indicated in dotted lines, and

Figure 3 is a longitudinal section through a locomotive tender provided with a modified form of construction.

Referring to Figs. 1 and 2 of the drawings, the principal parts of the construction may be enumerated briefly as follows. 1 is the rear end of the locomotive fire-box provided with a pair of under-feed troughs 2—2 and grate 3; 4—4 are a pair of auxiliary feed pistons operating in the under-feed troughs; 5—5 are the main feed pistons operating at the rear of the troughs 2—2 in feed chambers 6—6; 7 is a rock shaft operated from the steam cylinder 8, which rock shaft carries the crank arm 9 secured at its upper end to the two connecting rods 10—10 (Fig. 2); 11 is a cross bar to which the rear ends of the connecting rods 10—10 are secured, which cross bar is the operating member for the main feed pistons 5—5;

12 is the floor of the tender provided with the gravity feed passage 13; 14 is the crushing piston provided with the agitating means 15 and reciprocated from the pistons 5—5 by means of the pair of connecting rods 16—16 pivoted to the opposite sides of the piston 14 at 17; 18 is the chute into which the piston 14 discharges, which chute discharges at its front end to the pistons 5—5; 19 are reciprocatory bars mounted in the upper portion of the chute 18 and provided with the feed flaps 20; 21 is the preliminary feeding piston carried by the bars 19; 22 is a door for controlling the flow of fuel to the outlet passage 13; and 23 is the operating lever for controlling the position of the door 22.

The bars 19 are provided with a cross member 24 carrying at its opposite ends the links 25, which links are connected at their front ends to the links 26—26 lying on opposite sides of the feed chute. These links 26 are operated from the connecting rods 16—16 by means of the connecting rods 27—27. The operating lever or handle 23 is carried by the rock shaft 28, which rock shaft is connected to the door 22 by means of the link members 29 and 30 as indicated in Fig. 1.

The operation is as follows. Coal is fed by gravity through the passage 13 to the front of the piston 14. The forward movement of this piston carries the coal into the chute 18, crushing the larger lumps and reducing the coal to a size suitable for use in the fire-box. The forward movement of the piston 21 carries the coal to a position where it can be engaged by the rearmost flap 20, and the reciprocatory movement of the bars 19 gives the coal a step-by-step movement longitudinally of the trough from which it is finally discharged to the front of the pistons 5 and then into the fire-box.

A modified construction is shown in Fig. 3. In the arrangement here shown the crushing piston 14' works rearwardly instead of forwardly, and the coal is discharged into a hopper 31 thence to the front of the piston 21' working the chute 18'. The piston 21' is carried by bars 19' which also carry the flaps 20', the operating connection being substantially the same as those heretofore described in connection with Figs. 1 and 2. The piston 14' is provided with agitating means 15' correspond-

ing to the means employed in the other form of apparatus, and the door 22' is operated in the same manner as the corresponding door of the construction of Figs. 1 and 2.

The use of the additional plunger 14, instead of feeding directly in front of the piston 21 by gravity as has heretofore been done, is advantageous as the amount of fuel supplied to the chute 18 can be limited to the amount supplied by the piston 14, and all danger of clogging in the chute due to the overfeed at the rear end avoided. The result could obviously not be attained by a direct gravity feed from the tender to the chute in front of the piston 21. Other advantages incident to the construction will be apparent to those skilled in the art.

Having thus described my invention and illustrated its use, what I claim as new and desire to secure by Letters Patent is the following:—

1. In combination in apparatus for supplying coal to a locomotive fire-box, a tender provided with a gravity discharge passage, a crushing piston working transversely of the passage, a chute below the piston in position to receive the discharge from the passage and extending forwardly to a point adjacent the fire-box of the locomotive, a piston working in the chute at the rear end thereof, and reciprocatory means for forwarding the coal to the front end of the chute.

2. In combination in apparatus for supplying coal to a locomotive fire-box, a tender provided with a gravity discharge passage having a transverse portion, a crushing piston working in the transverse portion, a chute in position to receive the discharge from the passage and extending forwardly to a point adjacent the fire-box of the locomotive, a piston in the chute for giving the coal received its preliminary forward movement, and reciprocatory means in the chute for forwarding the coal there-through.

3. In combination in apparatus for supplying coal to a locomotive fire-box, a tender provided with a gravity discharge passage having a transverse portion, a piston working in the transverse portion, a chute in position to receive the discharge from the passage and extending forwardly to the locomotive, a receiving chamber in position to receive the discharge from the chute, a piston therein for forcing the coal into the fire-box, a piston in the rear portion of the chute for giving the fuel its preliminary forward movement, and reciprocatory means in the chute for forwarding the coal therethrough.

4. In combination in apparatus for supplying coal to a stoker, an underfeed trough, a main feed piston at the rear of the trough, an auxiliary feed piston in the trough, a rocker arm, means for oscillating it, and a connecting rod mounted intermediate its ends on the rocker arm and connected at one end to the main piston, and a link having pivotal connection to the other end of the said connecting rod and to the auxiliary piston.

5. In combination in apparatus for supplying coal to a stoker, a pair of underfeed troughs, a pair of main feed pistons at the rear of the troughs, a pair of auxiliary feed pistons in the troughs, a rocker arm intermediate the main pistons, a connecting bar between the main pistons, a pair of connecting rods carried by the rocker arm intermediate their ends and having their rear ends secured to the said bar and having their front ends turned laterally, and pivotal link connection between such front ends and the auxiliary pistons.

In testimony whereof I have hereunto signed my name in the presence of the two subscribing witnesses.

CHARLES D. YOUNG.

Witnesses:

E. B. WELSH,

E. A. SEARIGHT.