

(19) World Intellectual Property
Organization
International Bureau



(43) International Publication Date
27 October 2005 (27.10.2005)

PCT

(10) International Publication Number
WO 2005/099522 A2

(51) International Patent Classification⁷: **A47F**

(21) International Application Number:
PCT/GB2005/001393

(22) International Filing Date: 11 April 2005 (11.04.2005)

(25) Filing Language: English

(26) Publication Language: English

(30) Priority Data:
0408696.3 19 April 2004 (19.04.2004) GB

(71) Applicant and

(72) Inventor: DANIEL, Charles [DK/GB]; 13 Oakmead Gardens, Edgware, Middlesex HA8 9RW (GB).

(74) Agents: CARTER, Stephen et al.; Mewburn Ellis LLP, York House, 23 Kingsway, London, Greater London WC2B 6HP (GB).

(81) Designated States (unless otherwise indicated, for every kind of national protection available): AE, AG, AL, AM,

AT, AU, AZ, BA, BB, BG, BR, BW, BY, BZ, CA, CH, CN, CO, CR, CU, CZ, DE, DK, DM, DZ, EC, EE, EG, ES, FI, GB, GD, GE, GH, GM, HR, HU, ID, IL, IN, IS, JP, KE, KG, KM, KP, KR, KZ, LC, LK, LR, LS, LT, LU, LV, MA, MD, MG, MK, MN, MW, MX, MZ, NA, NI, NO, NZ, OM, PG, PH, PL, PT, RO, RU, SC, SD, SE, SG, SK, SL, SM, SY, TJ, TM, TN, TR, TT, TZ, UA, UG, US, UZ, VC, VN, YU, ZA, ZM, ZW.

(84) Designated States (unless otherwise indicated, for every kind of regional protection available): ARIPO (BW, GH, GM, KE, LS, MW, MZ, NA, SD, SL, SZ, TZ, UG, ZM, ZW), Eurasian (AM, AZ, BY, KG, KZ, MD, RU, TJ, TM), European (AT, BE, BG, CH, CY, CZ, DE, DK, EE, ES, FI, FR, GB, GR, HU, IE, IS, IT, LT, LU, MC, NL, PL, PT, RO, SE, SI, SK, TR), OAPI (BF, BJ, CF, CG, CI, CM, GA, GN, GQ, GW, ML, MR, NE, SN, TD, TG).

Published:

— without international search report and to be republished upon receipt of that report

For two-letter codes and other abbreviations, refer to the "Guidance Notes on Codes and Abbreviations" appearing at the beginning of each regular issue of the PCT Gazette.

(54) Title: SHELVING

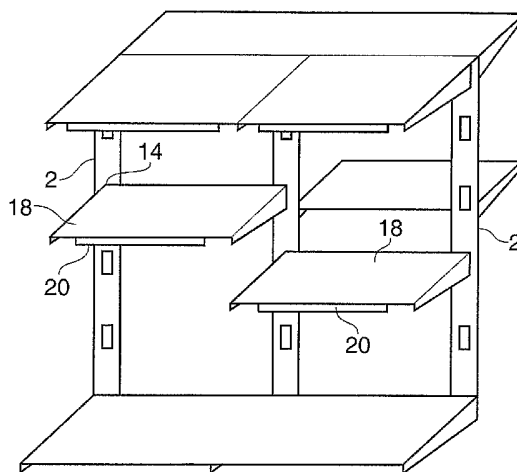

(57) Abstract: The present invention provides an assembly that can be retrofitted to a shelving system to power or provide data to electrical or electronic components (20) mounted on shelves (18). The assembly comprises a cartridge (4) including a longitudinal channel section having at least a partially open interior with at least one opening thereto, and at least one conducting insert (6) located in and extending along the open interior of the channel section; and a conducting strip element (16) which is configured at one end for introduction into the interior of the channel through the at least one opening to make a conducting contact with the conducting insert, and which is configured at its other end for connection to an electrical or electronic component (20). The cartridge (4) can be mounted within an upright support member (2) of a conventional shelving system and the conducting strip element (16) mounted on the shelf bracket (12) of a conventional shelving system such that when the bracket (12) is mounted on the upright support member (2), one end of the strip element (16) contacts the conducting insert (6) in the cartridge (4).

WO 2005/099522 A2

SHELVING

Field of the Invention

5 The present invention relates to shelving. In particular it relates to the incorporation of electrical and electronic components such as lamps, display units and the like, preferably together with a power supply and/or data connection, into shelving systems such as those used in shops and stores.

Background

10 Conventional standard shelving systems used in shops and stores typically consist of a number of hollow, upright support members, each having a series of slot openings running down at least one side (and often two opposite sides) of each support. Shelf brackets hook into the slot openings and extend forwardly from the uprights either horizontally or, in some cases, optionally at a downwardly sloping angle. The shelves themselves sit on top of and are supported by the
15 brackets. In some systems, the brackets may be formed integrally with the shelves.

Shelving systems with integral lighting are known and have been proposed for use in shops and stores. An example is seen in US 4,689,726, which describes a lighting arrangement for a shelving system with adjustable shelves in which power is supplied via a supporting structure of
20 the shelf to a lamp fixture mounted under the front edge of the shelf.

Another system is described in WO 03/063655, in the name of the present Applicant, where a shelving system solution is described that is better suited for larger scale installations. In this system the shelves may also be located at numerous positions throughout the height of the
25 system, but this system also permits an ease of installation due to the arrangement of the electrical wiring and its relationship to the shelves.

However, these and other existing shelving systems incorporating lighting require custom shelves and/or shelf supports and typically involve the use of wiring which must be run within the shelving
30 system components or otherwise hang outside the components in an unsightly and potentially dangerous fashion. The position of such shelving systems within a shop or store is also restricted by the existing location of power supply sockets.

As a consequence, none of the existing shelving systems have met with much commercial
35 success. Shops and stores (and other users of shelving) are also generally reluctant to use non-standard shelving systems, not least because they have often already invested heavily in the installation of their standard shelving systems.

Summary of the Invention

According to a first aspect of the present invention there is provided an assembly for use with a shelving system, the assembly comprising:

5 a cartridge including a longitudinal channel section having at least a partially open interior with at least one opening thereto, and at least one conducting insert located in and extending along the open interior of the channel section; and

10 a conducting strip element which is configured at one end for introduction into the interior of the channel through the at least one opening to make a conducting contact with the conducting insert, and which is configured at its other end for connection to an electrical or electronic component.

In some embodiments the assembly can be used to provide power to a lamp fixture or other electrical or electronic component mounted on a shelf. In this case the conducting insert and strip
15 element are conductors of electricity. In other embodiments the assembly can additionally or alternatively serve as a conduit for data, for example to control an electronic display unit or sound generating unit. In this case the conductors carry data (and optionally also power).

More specifically, the cartridge can be arranged for mounting on or, more preferably within, an
20 upright support member of a conventional shelving system and the conducting strip element arranged for mounting on the shelf bracket or shelf of a conventional shelving system such that when the bracket is mounted on the upright support member, one end of the strip element contacts the conducting insert in the cartridge. With a cartridge and strip element at either end of a shelf, an electric component on the shelf can be connected to a power supply connected across
25 the conductors in the two cartridges. Alternatively, it is possible to use a single cartridge to connect a power supply to one pole of the electrical component, the other pole of the component being connected in another way. For instance, one of the shelf brackets may itself serve to do this, or some other convenient, conducting element of the shelf structure may serve this purpose. Similarly a connection can be made via cartridges in one or both uprights to a data 'supply' such
30 as a computer network.

The ability to incorporate the assembly into standard shelving systems, without the need for any modification of the existing components of the system, means it can easily be retro-fitted to existing shelving installations and easily incorporated into new installations.

35

According to a second aspect of the present invention there is provided a shelving system comprising:

- at least one shelf having an electrical or electronic component mounted thereon;
- a support structure including at least two generally upright support members and a shelf support bracket mounted on each support, wherein the at least two support members and brackets provide support for the at least one shelf; and
- at least one assembly as set forth in the first aspect above, wherein the cartridge of the assembly is mounted within an upright support member and the conducting strip element is mounted on the associated bracket so that one end of the strip element is in conducting (e.g. electrical) contact with the conducting insert of the cartridge and the other end is in conducting (e.g. electrical) contact with the electrical or electronic component.

The shelf support brackets may be formed integrally with the shelf, but will typically be separate components as is common in known shelving systems.

15

In a third aspect, the invention provides a shelving system comprising:

- at least one shelf having an electrical or electrical component mounted thereon;
- a support structure for the shelf; and
- at least one conducting strip element mounted on the shelf or the shelf support structure to provide at least part of an electrical circuit between the electrical component on the shelf and a power supply, or at least part of a data connection between the component on the shelf and a data 'supply'.

According to a fourth aspect of the present invention there is provided a method of modifying an existing shelving system, the existing shelving system comprising at least one shelf having an electrical or electronic component mounted thereon and a support structure including at least two support members, wherein the at least two support members provide support for the least one shelf, the method comprising the addition of an assembly according to the first aspect above to the existing shelving system, the cartridge of the assembly being inserted into at least one of the support members, and the conducting strip element of the assembly being applied to the at least one shelf or bracket supporting it to connect the conducting insert of the cartridge to the electrical or electronic component when the shelf is mounted on the support structure. Alternatively, the existing shelving unit may not include an electrical or electronic component, which may instead form part of the assembly to be added to the existing structure.

35

In the various aspects of the invention set forth above, the conductive strip element can be any of a number of suitable strip or tape-like elements that are or incorporate an electrical or data

conductor. The preferred aim is to provide, as an alternative to conventional wires used with existing shelving systems, a relatively flat element that can be adhered to the exterior of a shelf bracket to provide a conductive path (e.g. electrically conductive path or data conduit) from one end of the bracket to the other.

5

The conductor part of the strip element is preferably insulated along a majority of its length, being exposed only in areas (typically at either end) where conducting contact with other elements is needed. The conductor may, for example, be mounted on or sandwiched within an insulating substrate. In this case, the conductor can be applied to the substrate in any of a number of
10 suitable ways. For example it may be printed on, adhered to or simply sandwiched within the substrate material.

In particularly preferred embodiments, the strip element takes the form of a PCB, most preferably a flexible PCB. Other suitable forms for the strip elements include insulated foil or ribbon tapes
15 (e.g. insulated copper tape). The strip may also itself perform some other function. For instance, an LED or other similar lighting strip may serve this role as well as itself providing additional lighting for the shelf. Another example of a possible data conductor is an optical fibre.

The conductive strip element preferably comprises adhesion means on one side to allow it to be
20 easily adhered to the bracket of a shelf. The strip element may be supplied, for example, with a layer of an adhesive on one side covered by a removable backing strip. Where provided, the adhesive means may have electrical insulating properties and serve to insulate one side of the conductor.

25 The at least one opening of the cartridge is preferably located adjacent the slot openings of the upright support members (when installed) in order that the strip element (e.g. when mounted on a shelf bracket) can extend through a slot opening to the interior of the cartridge to make contact with the conductor in the cartridge.

30 Preferably the cartridge has a generally C-shaped cross-section. Alternatively the cartridge has any suitable cross-section which allows it to be inserted into, and retained by, the interior of a support member. The cartridge may have one elongate opening along its length or a series of holes, which correspond to the location of the slots in the support members.

35 For ease of installation it is preferred for the support members of the shelving system to have a hollow interior (as is normal). However, the cartridge may be suitably shaped to accommodate any irregularities of shape in the interior of the support members or adapted for mounting to the

exterior of the support member.

In order to ensure that the assembly is electrically insulated, thus making any shelving system the assembly is incorporated with safe for use and to guard against any short-circuiting, the cartridge is preferably made from a material with electrical insulating properties. For instance a plastics material or hardened rubber material or the like could be used. Alternatively or additionally, the cartridge could have a layer of suitable electrically insulating material applied thereto. This insulating layer could be applied between the inner surfaces of the cartridge and the conducting insert. Alternatively or additionally, this insulating layer could surround the outer surfaces of the cartridge.

The shelf can be fitted with any desired electrical or electronic component, for instance a lamp, an electronic display, a speaker or the like. Preferably the component is attached to the underside of the shelf so that, in use, it is largely hidden from view (other than those parts which are intended to be seen, such as a display). Such a form of attachment allows the component, such as a lamp or display, to be associated with the shelf positioned below the shelf to which the component is attached (e.g. to illuminate the shelf below where the electrical component is a lamp).

The at least one conducting insert contained in the cartridge can be made from any suitable conducting material (e.g. electrically conducting material or data carrier). Preferably the at least one conducting insert is attached to the inner surface of the cartridge which is opposite the at least one opening. The or each conducting insert preferably extends along substantially the whole length of the cassette to provide for conducting connection to a shelf mounted at any height on the support member in which the cassette is installed.

The at least one conducting insert preferably has at least one protruding portion which extends into the interior of the cartridge. Where there is only one conducting insert, the insert preferably has two protruding portions. Where there are two conducting inserts present, each insert preferably has only one protruding portion and the inserts are preferably arranged one to either side of the channel opening(s).

Preferably the protruding portion(s) extends into the interior such that it is suitably located to bear against a conducting strip element upon the strip element's insertion into the cartridge's at least one opening. Ideally the conducting insert has a tapered channel cross-section (naturally if the insert only has one protruding portion the cross-section will be that of half a channel). Such tapering may permit the conducting insert to act as a leaf spring, such that the inherent resilience of the insert holds it against an introduced conducting strip element.

Where the shelving systems are orientated in a back-to-back configuration, such that support members are configured to support shelves on both front and rear sides via two sets of opposed slot openings, cartridges may be inserted into the support member in a back-to-back orientation.

5 Alternatively, generally H-section cartridges can be used having the form of two back-to-back channels to provide the same function.

To power an electrical component (e.g. a lamp) on a shelf, the two poles of a power supply must be electrically connected to opposite poles of the component. Typically this is achieved in shelving systems according to preferred aspects of the present invention by mounting one of the cartridges in each of the two upright supports that the shelf is mounted on (typically one at each end of the shelf). One pole of the electrical component is connected to the conductor in the cartridge at one end of the shelf by a first conducting strip element and the other pole to the conductor in the other cartridge at the other end of the shelf by another conducting strip element in accordance with aspects of the invention above. Alternatively, conductors for both poles of the power supply / electrical component can be housed within a single cartridge in a support at one end of the shelf, or a connection to one of the poles of the electrical component may be made via some other component, including for example a component of the shelf structure.

20 Multiple shelves can be mounted, in a known manner, on the two supports one above the other and each can, if desired, carry an electrical or electronic component connected in parallel with one another to the power supply (or data 'supply') in the manner described above.

Normally, a shelving system will comprise a series of shelves arranged in side-by-side bays, the shelves of adjacent bays sharing a common upright support. In this case, in accordance with preferred aspects of the present invention, the shelves of adjacent bays can also share a cartridge mounted within the support they share.

Similarly, it is common for shelving systems to be arranged to provide shelves back-to-back and the back-to-back shelves can share a cartridge within a shared support member. In back-to-back shelving systems also with multiple shelving bays side-by-side, one upright support member and its associated cartridge can support and provide electrical and/or data connections for the four shelving bays adjacent to it.

35 Where a cartridge is shared by two or more adjacent shelving bays, it may be desirable to provide separate conductors (insulated from one another) within the cartridge for each bay. This is likely to be essential when the conductors are for DC power supply.

Particularly where the conductors are for an AC power supply, however, it may be possible for the shelves in two or more adjacent bays to share a conductor within the upright support. Use of an AC supply also has the benefit that it does not matter which pole of the electrical components is connected to which pole of the power supply. This insensitivity to orientation of the connection is a great benefit when installing the shelving system.

In a fifth aspect the present invention provides a shelving system comprising:

- at least two shelves mounted side-by-side, each shelf having an electrical component mounted thereon;
- a support structure for the shelves comprising at least three upright support members, each of the at least two shelves being supported by two of the three support members so that one of the support members is shared by both shelves;
- an electrical conductor associated with each of the three support members, the electrical component on each shelf being electrically connected across the conductors in the two upright supports that support it, the electrical components both being connected to the conductor in the shared support; and
- one or more AC power supplies connected across each adjacent pair of conductors.

In modular shelving systems it is known to mount a tray across the top of the upright supports, spanning from one support to the next. This is generally for aesthetic reasons and can also serve to prevent products falling between two supports. Conveniently, in preferred embodiments of the various aspects of the present invention, a power supply or connections to a power supply are mounted on a modified top tray that spans adjacent upright supports, opposite ends of the top tray being adapted for electrical connection to the top end of the conductors of the cassettes mounted within the uprights to electrically connect them to respective poles of the power supply in use.

In a sixth aspect, the invention provides a shelving system comprising:

- at least one shelf having an electrical component mounted thereon;
- a support structure for the shelf comprising at least two upright support members;
- an electrical conductor associated with each of the two support members, the electrical component on the shelf being electrically connected across the conductors in the two upright supports that support it; and
- a top tray connects the top ends of the upright supports, the top tray having a power supply or connections to a power supply mounted on it and opposite ends of the top tray being adapted for electrical connection to the top end of the conductors associated with the upright

supports to electrically connect them to respective poles of the power supply.

The power supply, which is preferably an AC power supply, may be connected to contacts at opposite ends of the top tray by conventional wiring, but is preferably connected using conducting
5 strip elements of the form described above.

In some shelving installations it is difficult to provide an external power supply. It may still be desirable, however, to provide lighting for the shelves or to power some other electrical component mounted on a shelf.

10

In a seventh aspect, the invention provides a shelving system comprising:

at least one shelf having an electrical component mounted thereon; and

a top panel having an upwardly facing surface;

the top panel having a solar panel on its upwardly facing surface, the solar panel being
15 electrically connected to the electrical component on the shelf to power it.

The top panel may itself be a shelf and/or may have an electrical component mounted thereon that is also powered by the solar panel.

20 In a typical shelving installation in a shop or store, the light from the main overhead lighting is sufficient for the solar panel to generate sufficient power for a variety of different electrical components. The electrical component(s) may, for example, be LEDs or other lamps whose power requirement can be met by the solar panel.

25 Brief Description Of The Drawings

Embodiments of the invention are described below by way of example with reference to the accompanying drawings in which:

Fig. 1 shows a perspective view of a known shelving system, modified in accordance with the
30 present invention;

Fig. 2 shows a sectional plan view of a support member containing a cartridge housed therein in accordance with an embodiment of the present invention;

35 Fig. 3 shows a sectional plan view of a support member containing two cartridges housed therein in accordance with an embodiment of the present invention;

Fig. 4 shows the cross-sectional view of the Fig 2 assembly with a shelf engaged;

Fig. 5 shows a perspective cut away view of the Fig 2 assembly;

5 Fig. 6 shows a sectional side view of the Fig. 4 assembly;

Figs. 7(a), (b) and (c) show a pcb-type strip conductor used in embodiments of the present invention;

10 Fig. 8 shows schematically the AC electrical power circuit for a shelving system according to an embodiment of the invention;

Fig. 9 shows an embodiment of the invention in which a power supply and its connections are mounted on a top tray of a shelving system;

15

Fig. 10 shows a solar powered display unit in accordance with an embodiment of the seventh aspect of the invention; and

20

Fig. 11 shows another solar powered display unit in accordance with another embodiment of the seventh aspect of the invention.

Description of Embodiments

The various aspects of the invention are exemplified below with reference to systems in which power is supplied to shelf mounted components. Similar arrangements can be used to supply data to shelf mounted components.

25

As shown in Fig. 1 a shelving system is formed from a number of support members 2 which are joined to one another to form a support structure or frame. The frame in turn supports shelves which can be supported at any angle relative to the support structure, preferably, horizontally thereto. Specifically each shelf is supported by two or more of the upright support members 2, this example shows several shelves, each supported by two of the three support members 2 wherein all of the shelves share the middle support. As will be appreciated, such a shelving system can be easily expanded to incorporate additional support members and additional shelves.

35

At least some of the shelves 18, potentially all of them (with the possible exception of the shelves at the base of the structure) have an electrical component 20 mounted on their underside adjacent to their front edge. Preferably the electrical component is a lamp which, and for the sake of convenience, shall be referred to as such hereinafter. Power is supplied to the lamp as will be described below.

Looking at Fig. 2 an upright support member 2 of an existing shelving system is illustrated. The support 2 has a generally rectangular cross-section and is designed to allow shelves to be located to both its front and rear sides. The support member 2 has a hollow interior into which has been inserted a cartridge 4 having a generally C-shaped cross-section. The cartridge 4 is also provided with a hollow interior. On the interior face of the cartridge, opposite the open portion thereof, is located an electrically conducting insert 6. The conducting insert 6 is connected at one end to a power supply (preferably and AC power supply) (not shown) and is disposed to form electrical contact(s) in order to power the lamp, as described in more detail below.

The conducting insert 6 has at least one protruding portion 8 but preferably two portions, which extend into the interior of the cartridge 4. The conducting insert 6 has a generally tapered channel cross-section with flanged extremities. Such tapering permits the conducting insert 6 to act as a leaf spring such that should any contact be made against either of the protruding portions 8 their inherent resilience will act to maintain the contact thereagainst.

Fig. 2 shows a cartridge which has been inserted into the supporting structure together with a blank cartridge 10. The blank cartridge 10 is of the same dimensions as cartridge 4; the difference being that the blank cartridge 10 contains no conducting insert. The blank cartridge 10 allows cartridge 4 to be securely located in the support member 2. However, as shown in Fig. 3, it is possible that the blank cartridge 10 could be replaced by a cartridge 5 identical to cartridge 4 containing the conducting insert 6, i.e. two cartridges 4, 5 in a back-to-back orientation. Such an orientation of cartridges would allow power to be supplied to shelves located to both the front and rear of the support member 2. It is also possible for two back-to-back cartridges to be formed as one generally H-shape cartridge.

Turning to Figs. 4-6, it can be seen that a bracket 12 has been inserted into a slot 14 in the support member 2. The bracket 12 is located to hold a shelf 18 thereon. That said, the bracket 12 could of course be integral with the shelf 18 located at each shelf end.

The bracket 12 has a hook formation at its end, which once introduced into the slot 14, is able to bear against the interior of the support member 2 to hold the bracket 12 in place. An electrically

conducting strip 16 (described in more detail below) is attached to the side of the bracket and extends to, or close to, the end of the hook formation of the bracket 12. Thus, once the bracket 12 has been inserted into the slot 14 such that the bracket is fixed to the support member 2, the conducting strip 16 will be brought to bear against a protruding portion 8 of the conducting insert 6, thus making an electrical contact.

The conducting strip 16 extends along the length of the bracket 12 toward the front of the shelf 18. Under the front lip of the shelf is mounted a lamp 20 and the strip 16 is in electrical contact with this. At the other end of the lamp is a corresponding connection with another conducting strip 16' (not shown) which also extends along the length of the bracket 12' (not shown) located at the other end of the shelf. Similarly, strip 16' is also capable of forming an electrical contact with a protruding portion 8' (not shown) of a corresponding cartridge 4' (not shown) in the adjacent support structure 2' (not shown). The protruding portion 8' forms part of a conducting insert 6' (not shown) which is also connected to the power supply. The terminals of the lamp can be connected to the outer ends of the conducting strips in any of a number of suitable ways. Preferably a flat contact is arranged to the underside of each end of the shelf to make contact with an exposed outer end of the respective conducting strip, and a conductor (which may itself have a strip form) connects each contact to a respective lamp terminal. The above arrangement completes an electrical circuit and the lamp can be lit.

Turning to Fig. 7, one example of a suitable strip conductor is illustrated. In this example, the strip 16 is constructed as a flexible pcb with a conducting element 22 sandwiched between two insulating, flexible, tape layers 24. The conducting element is exposed at either end 26,28 to facilitate the necessary electrical connections. One face of the strip carries an adhesive layer that can be used to adhere the strip onto a shelf bracket 12.

Fig. 7(a) shows the pcb alone. Figs. 7(b) and (c) show the pcb adhered to a shelf bracket 12. As best seen in Fig. 7 (c), the exposed ends 26,28 of the conducting element 22 are arranged to wrap over respective ends of the shelf bracket 12 to help facilitate the electrical connections.

Although the above describes the arrangement of components for just one shelf, this arrangement is scalable to any number of shelves to be contained in the shelving system.

Fig. 8 illustrates schematically the way in which AC power supplies 30 can be used to power e.g. under shelf lighting in accordance with embodiments of the present invention. As can be seen, the conductors 6 within the upright shelf supports are shared by adjacent shelves 32 and are therefore each connected to two adjacent AC power supplies 30.

Fig. 9 shows a modified top tray 40 for a shelving unit that can be used to power e.g. under-shelf lighting in accordance with an embodiment of the present invention. A power supply (transformer) 42 is mounted on the top tray (in this case to the underside). The two poles of the power supply on its output side 44 are connected to respective spring contacts 46 to opposite
5 ends of the top tray 40. These spring contacts are arranged on the underside of the top tray such that when the top tray is installed on the shelving system they will make electrical contact with top ends of conductive strips 6 housed within respective upright shelf supports 2 on which the top tray 40 sits. In this way, power can be supplied via these connections to lamps on the shelves via the conductive strips 6.

10

The input side 48 of the power supply is connected to a conductor 50 (which may, if desired, be a pcb-type strip conductor of the form discussed above), also mounted on the top tray. This conductor has connectors 52 at either end to allow connection to the conductor of an adjacent top tray or to an external power source.

15

For some shelving installations or display units, it may be awkward to connect an external power supply. An example is a pedestal-type-shelving unit 60 as illustrated in Fig. 10. This unit is designed to be positioned in the middle of an open floor space, where it is quite possible that there will be no convenient power supply.

20

In order to conveniently power lighting (or other electrical components) mounted on such a shelving unit 60, the embodiment of the invention illustrated in fig. 10 has a solar panel 62 mounted on the top of the unit. This panel can use light e.g. from a shops main overhead lighting to power lighting on the shelves 64 below. In this example, the lighting is provided in the form of
25 LED lighting strips 66, the low power requirements of which make them well suited to this form of power supply.

30

The solar panel 62 is connected to conductors 68 housed within the central shelf support 70 and the connection between these conductors and the LED lighting strips can be made with pcb-type connectors 72 mounted on shelf support brackets 74 in the same manner that has already been described above.

35

Fig. 11 illustrates another configuration of shelving unit incorporating a solar panel 62' power supply. The supply of power to the undershelf lighting (which in this example is also LED strip lighting 66') can be achieved in the same manner as described above in conjunction with figs. 1 to 6, save that the power supply is replaced by a solar panel 62'.

It is to be remembered that the above specific embodiment describes some embodiments of the present invention by way of example. Many more embodiments are achievable within the ambit of the invention.

CLAIMS

1. An assembly for use with a shelving system, the assembly comprising:
a cartridge including a longitudinal channel section having at least a partially open
5 interior with at least one opening thereto, and at least one conducting insert located in and
extending along the open interior of the channel section; and
a conducting strip element which is configured at one end for introduction into the
interior of the channel through the at least one opening to make a conducting contact with the
conducting insert, and which is configured at its other end for connection to an electrical or
10 electronic component.
2. An assembly according to claim 1, wherein the conducting insert and strip element
are conductors of electricity.
- 15 3. An assembly according to claim 1 or claim 2, wherein the conductors are adapted to
carry data.
4. An assembly according to any one of the preceding claims, wherein the cartridge is
arranged for mounting on or within an upright support member of a conventional shelving
20 system and the conducting strip element arranged for mounting on the shelf bracket or shelf
of a conventional shelving system such that when the bracket is mounted on the upright
support member one end of the strip element contacts the conducting insert in the cartridge.
5. A shelving system comprising:
25 at least one shelf having an electrical or electronic component mounted thereon;
a support structure including at least two generally upright support members and a
shelf support bracket mounted on each support, wherein the at least two support members
and brackets provide support for the at least one shelf; and
at least one assembly according to any one of the preceding claims wherein the
30 cartridge of the assembly is mounted within an upright support member and the conducting
strip element is mounted on the associated bracket so that one end of the strip element is in
conducting contact with the conducting insert of the cartridge and the other end is in
conducting contact with the electrical or electronic component.
- 35 6. A shelving system comprising:
at least one shelf having an electrical or electrical component mounted thereon;
a support structure for the shelf; and
at least one conducting strip element mounted on the shelf or the shelf support
structure to provide at least part of an electrical circuit between the electrical component on

the shelf and a power supply, or at least part of a data connection between the component on the shelf and a data supply.

5 7. A method of modifying an existing shelving system, the shelving system comprising at least one shelf, an electrical or electronic component mounted or mountable on the shelf and a support structure including at least two support members, wherein the at least two support members provide support for the at least one shelf, the method comprising the addition of an assembly according to any one of claims 1 to 4 to the existing shelving system, the cartridge of the assembly being inserted into at least one of the support members, and the
10 conducting strip element of the assembly being applied to the at least one shelf or bracket supporting it to connect the conducting insert of the cartridge to the electrical or electronic component when the shelf is mounted on the support structure.

15 8. A method according to claim 7, wherein the electrical or electronic component is part of the assembly to be added to the existing structure.

9. An assembly according to any one of claims 1 to 4, a shelving system according to claim 5 or claim 6, or a method according to claim 7 or claim 8, wherein the conducting strip element is a flat element that can be adhered to the exterior of a shelf bracket to provide a
20 conductive path from one end of the bracket to the other.

10. An assembly, shelving system or method according to claim 9, wherein the conductor part of the strip element is insulated along a majority of its length, being exposed only in areas where conducting contact with other elements is needed.
25

11. An assembly, shelving system or method according to claim 10, wherein the conductor is mounted on or sandwiched within an insulating substrate. In this case, the conductor can be applied to the substrate in any of a number of suitable ways.

30 12. An assembly, shelving system or method according to claim 11, wherein the conductor is printed on, adhered to or sandwiched within the substrate.

13. An assembly, shelving system or method according to claim 9, wherein the strip element is a flexible PCB.
35

14. An assembly, shelving system, or method according to any one of claims 9 to 13, wherein the conductive strip element comprises adhesion means on one side to allow it to be adhered to the bracket of a shelf.

15. An assembly, shelving system or method according to claim 14, wherein the adhesive means is an electrical insulator and serves to insulate one side of the conductor.
- 5 16. A shelving system according to claim 5 or any one of claims 9 to 15 when dependent on claim 5, the system comprising multiple shelves mounted on the two supports one above the other, two or more of the shelves carrying an electrical or electronic component connected in parallel with one another to the power supply or data supply.
- 10 17. A shelving system according to claim 5 or claim 16, comprising a series of shelves arranged in side-by-side bays, the shelves of adjacent bays sharing a common upright support, wherein the shelves of adjacent bays share a cartridge mounted within the support they share.
- 15 18. A shelving system according to any one of claims 5, 16 and 17, having a plurality of shelves arranged in back-to-back shelving bays, the back-to-back shelves sharing a cartridge within a shared support member.
- 20 19. A shelving system according to claims 16 to 18, wherein the cartridge shared by two or more adjacent shelving bays has separate conductors insulated from one another within the cartridge for each bay.
- 25 20. A shelving system according to any one of claims 16 to 18, wherein the conductors are for an AC power supply and the shelves in two or more adjacent bays share a conductor within the cartridge.
- 30 21. A shelving system comprising:
at least two shelves mounted side-by-side, each shelf having an electrical component mounted thereon;
a support structure for the shelves comprising at least three upright support
members, each of the at least two shelves being supported by two of the three support
members so that one of the support members is shared by both shelves;
an electrical conductor associated with each of the three support members, the
electrical component on each shelf being electrically connected across the conductors in the
two upright supports that support it, the electrical components both being connected to the
35 conductor in the shared support; and
one or more AC power supplies connected across each adjacent pair of conductors.
- 40 22. A shelving system according to any one of claims 5 and 16 to 20, comprising a power supply or connections to a power supply mounted on a modified top tray that spans adjacent upright supports, opposite ends of the top tray being adapted for electrical connection to the

top end of the conductors of the cartridges mounted within the uprights to electrically connect them to respective poles of the power supply in use.

23. A shelving system comprising:
- 5 at least one shelf having an electrical component mounted thereon;
a support structure for the shelf comprising at least two upright support members;
an electrical conductor associated with each of the two support members, the
electrical component on the shelf being electrically connected across the conductors in the
two upright supports that support it; and
- 10 a top tray connects the top ends of the upright supports, the top tray having a power
supply or connections to a power supply mounted on it and opposite ends of the top tray
being adapted for electrical connection to the top end of the conductors associated with the
upright supports to electrically connect them to respective poles of the power supply.
- 15 24. A shelving system according to any one of claims 5, 6 and 16 to 23, having an
upwardly facing top panel, the top panel having a solar panel of its upwardly facing surface to
provide power to one or more electrical and/or electronic components mounted on the
shelving system.
- 20 25. A shelving system comprising:
at least one shelf having an electrical component mounted thereon; and
a top panel having an upwardly facing surface;
the top panel having a solar panel on its upwardly facing surface, the solar panel
being electrically connected to the electrical component on the shelf to power it.

25

1/11

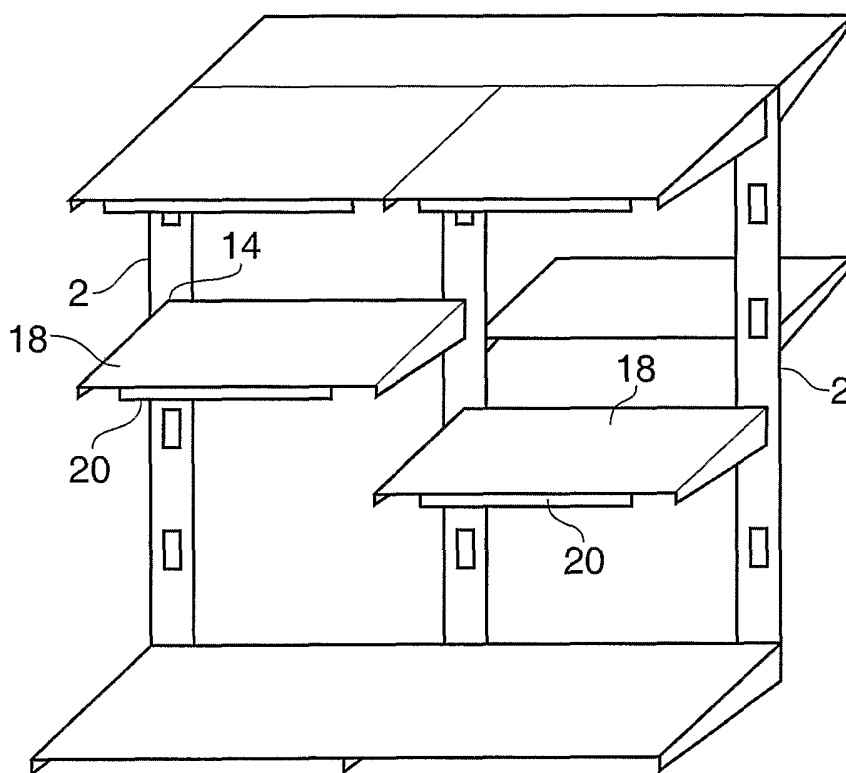

Fig. 1

2/11

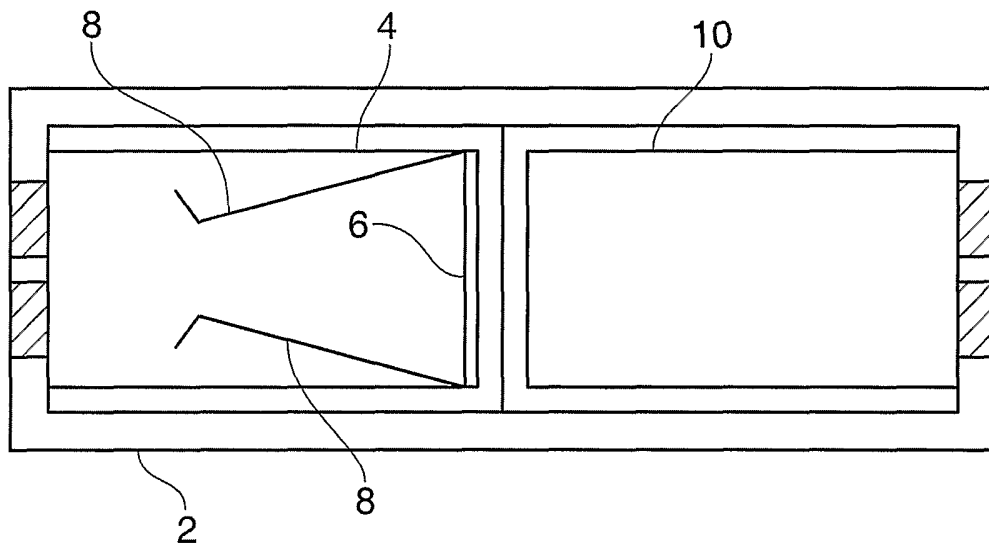

Fig. 2

3/11

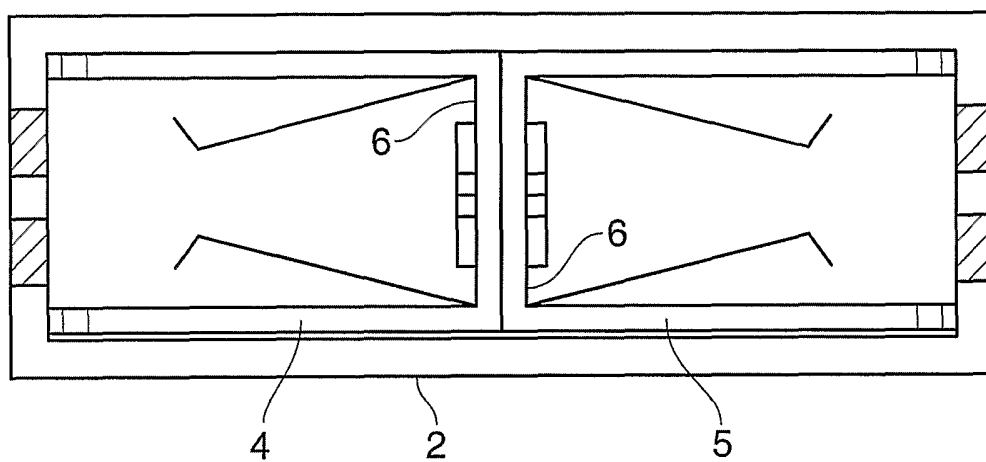

Fig. 3

4/11

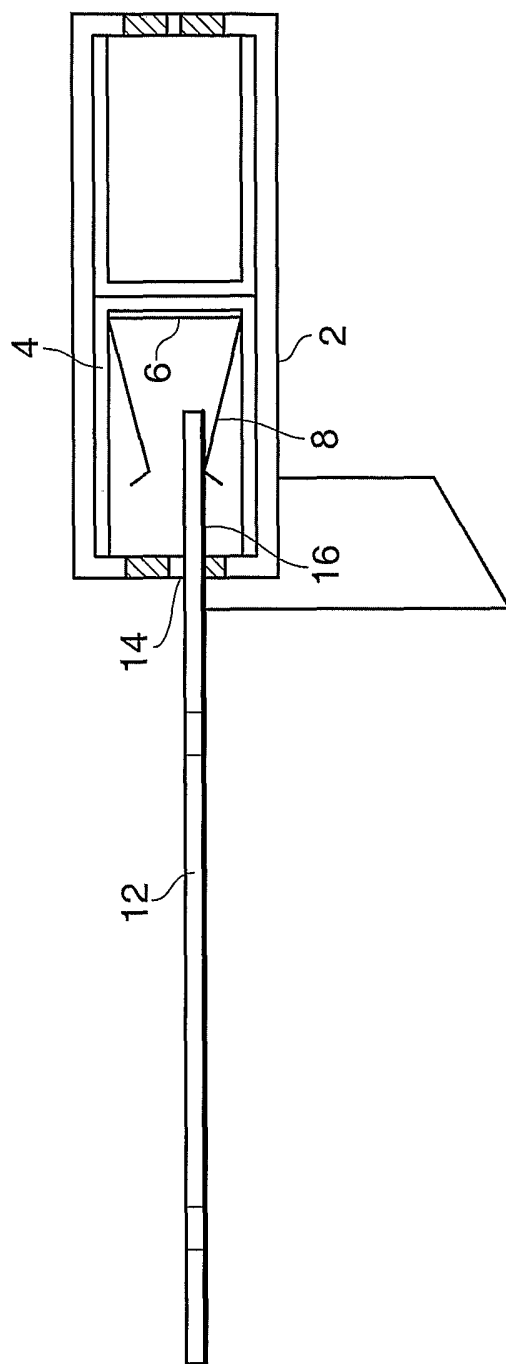

Fig. 4

5/11

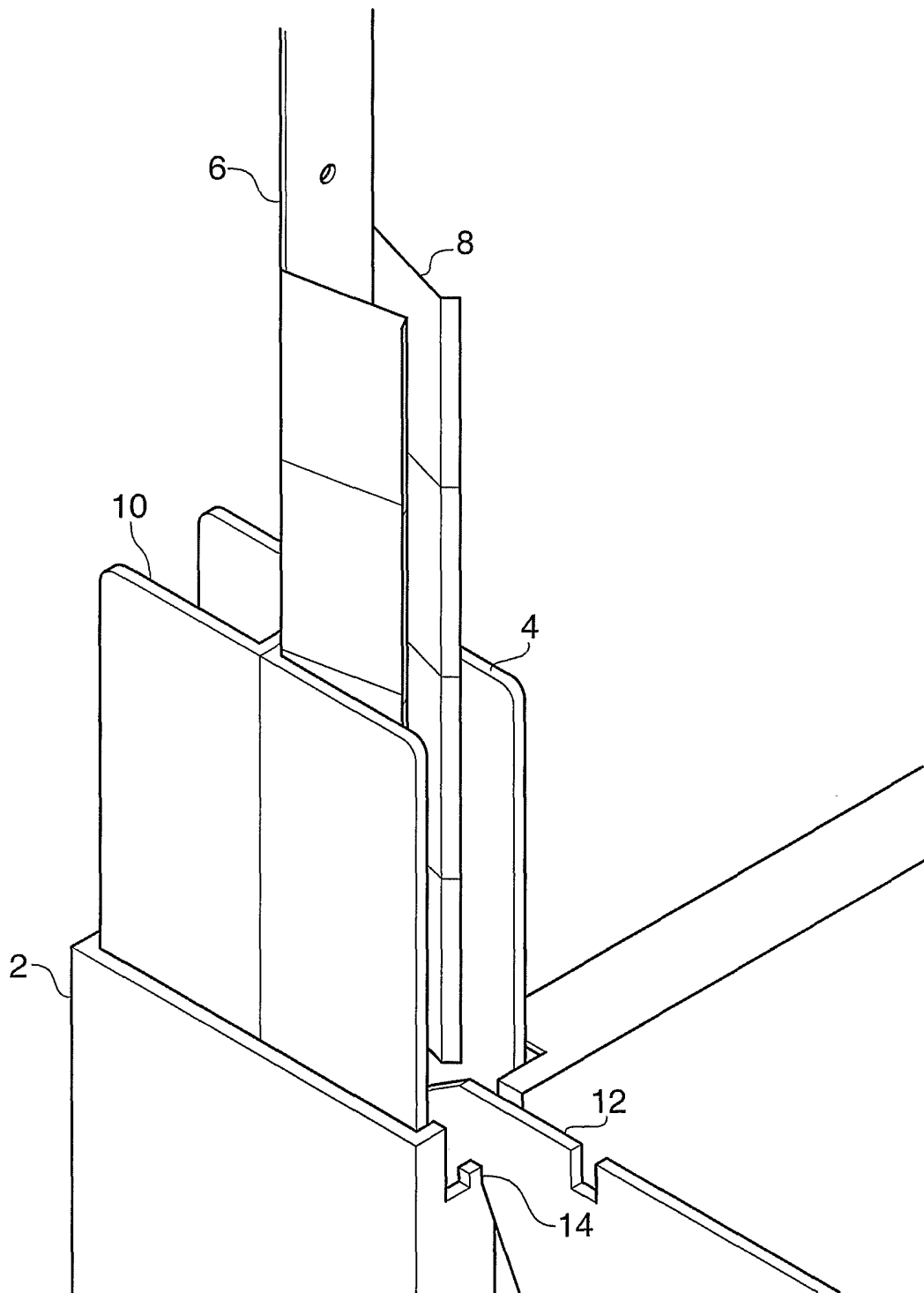

Fig. 5

6/11

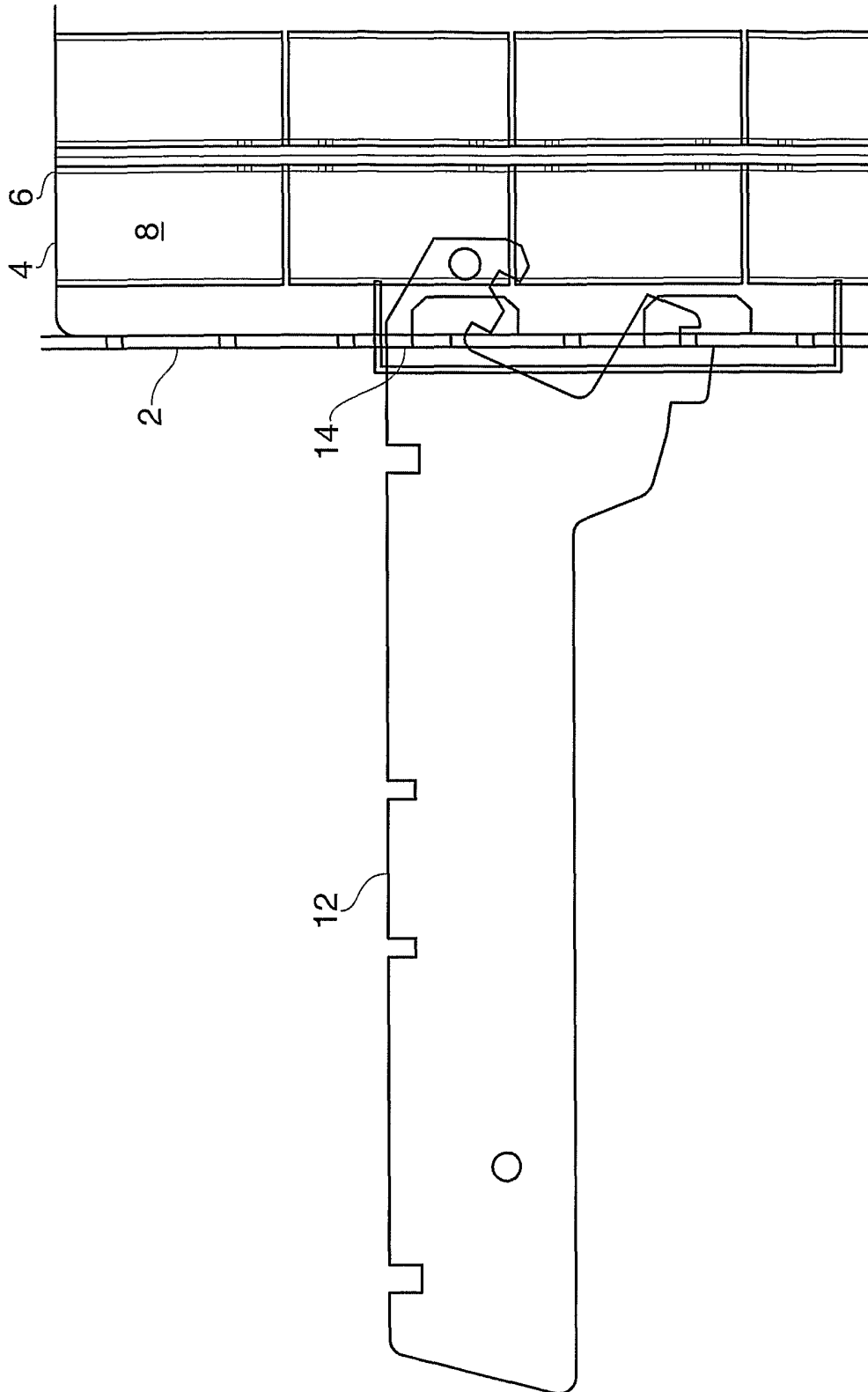

Fig. 6

7/11

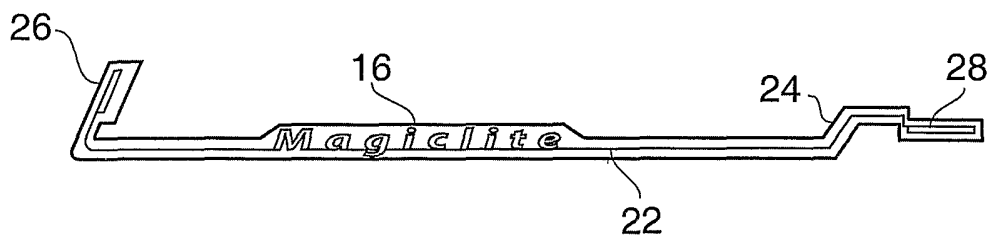

Fig. 7a

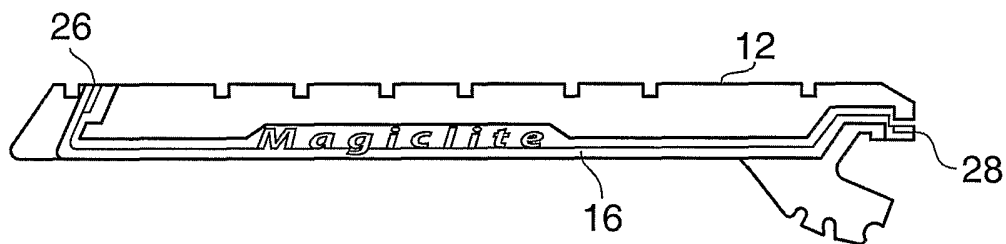

Fig. 7b

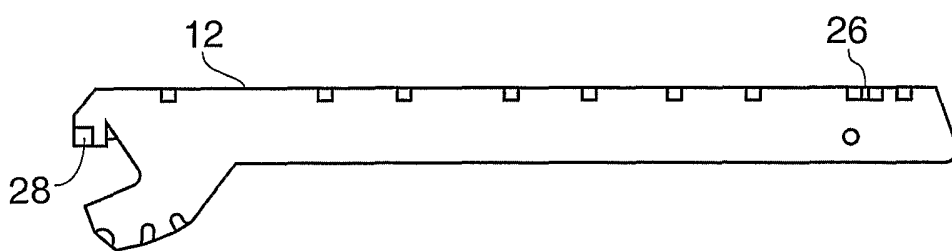

Fig. 7c

8/11

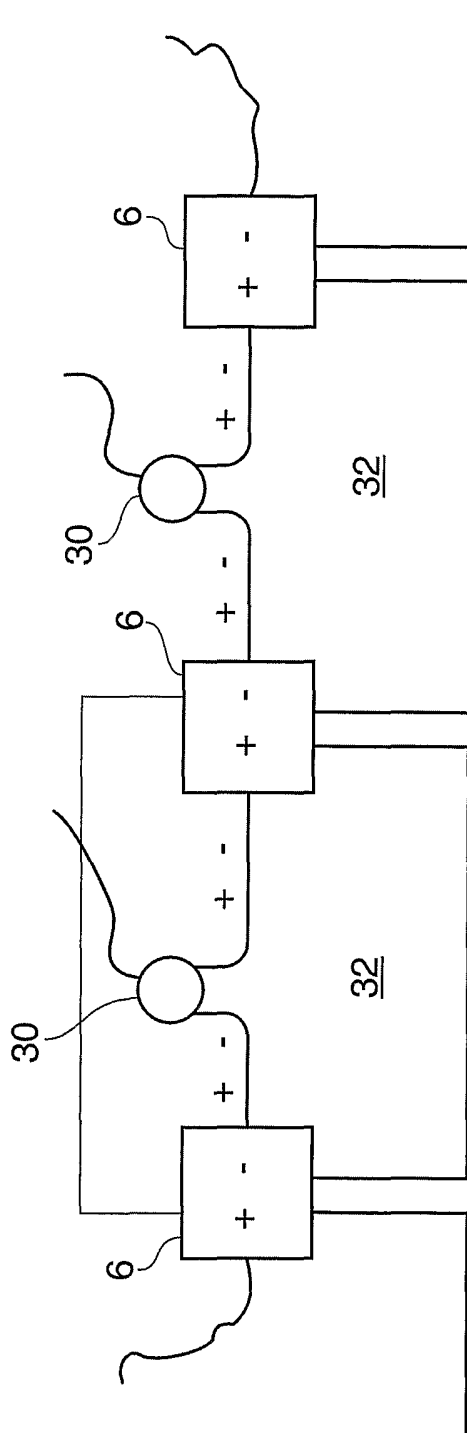

Fig. 8

9/11

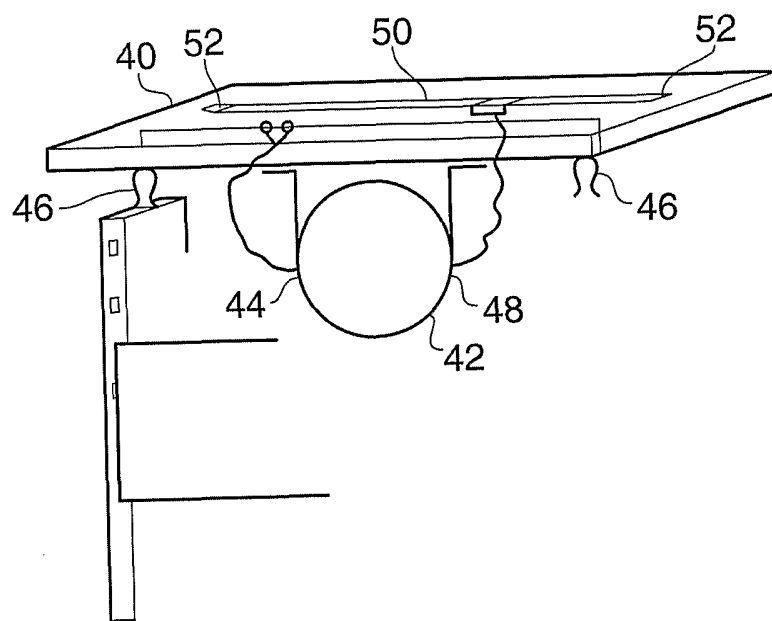

Fig. 9

10/11

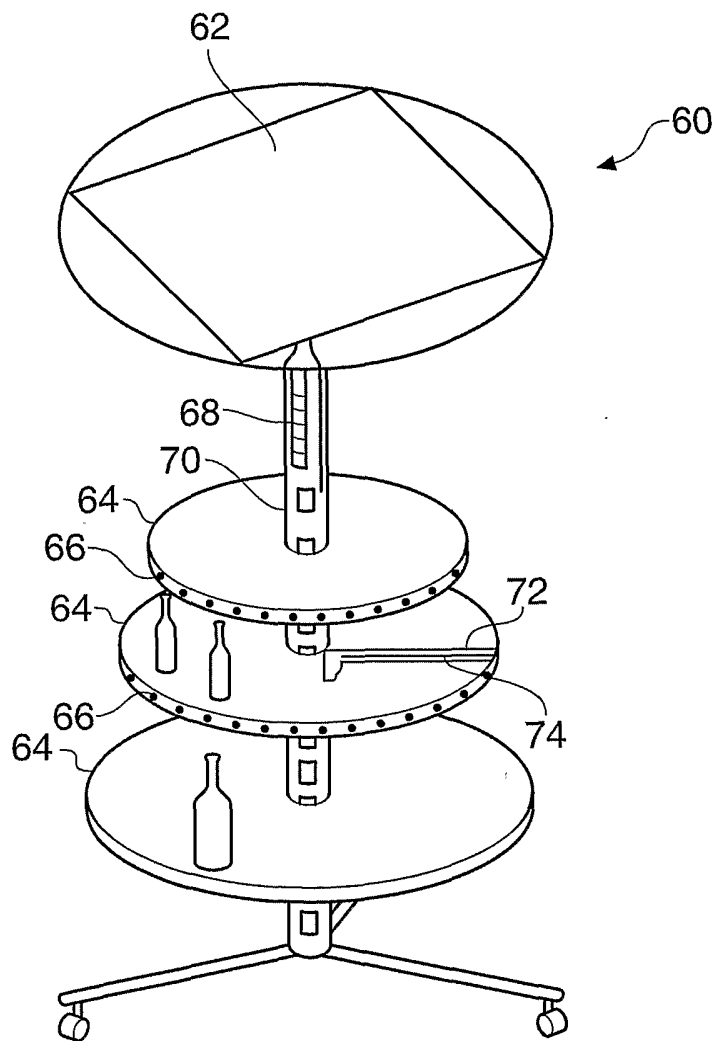

Fig. 10

11/11

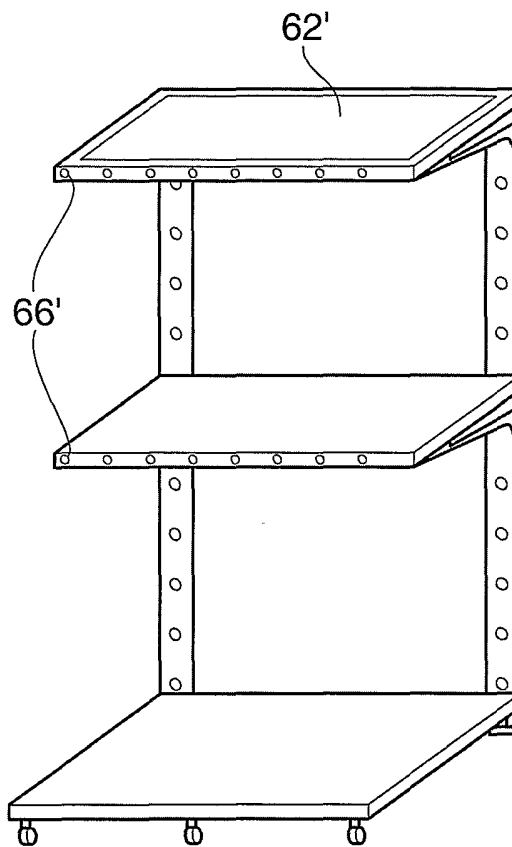

Fig. 11