



US 20090149803A1

(19) **United States**

(12) **Patent Application Publication**

Estes et al.

(10) **Pub. No.: US 2009/0149803 A1**

(43) **Pub. Date: Jun. 11, 2009**

(54) **SYSTEM FOR PROVIDING BLOOD GLUCOSE MEASUREMENTS TO AN INFUSION DEVICE**

(60) Provisional application No. 60/398,199, filed on Jul. 24, 2002, provisional application No. 60/412,998, filed on Sep. 23, 2002.

(75) Inventors: **Mark C. Estes**, Simi Valley, CA (US); **Cary D. Talbot**, Santa Clarita, CA (US); **"Mike" Charles Vallet Tolle**, Van Nuys, CA (US); **Jay A. Yonemoto**, Arcadia, CA (US)

Publication Classification

(51) **Int. Cl.**
A61M 5/168 (2006.01)
(52) **U.S. Cl.** **604/66**
(57) **ABSTRACT**

Correspondence Address:
MEDTRONIC MINIMED INC.
18000 DEVONSHIRE STREET
NORTHRIDGE, CA 91325-1219 (US)

An infusion system includes a characteristic determining device and an infusion device. The characteristic determining device includes a receptacle for receiving and testing an analyte from the user to determine a concentration of the analyte in the user. The characteristic determining device also includes a communication system for transmitting a communication including data indicative of the determined concentration of the analyte in the user, and the infusion device includes a communication system for receiving the communication from the characteristic determining device. The infusion device further includes a bolus estimator for calculating an estimated amount of fluid to be infused into the body of the user based upon the received data indicative of the determined concentration of the analyte in the user and a target concentration of the analyte in the user, and an indicator to indicate when the estimated amount of fluid to be infused has been calculated.

(73) Assignee: **MEDTRONIC MINIMED, INC.**, Northridge, CA (US)

(21) Appl. No.: **12/333,667**

(22) Filed: **Dec. 12, 2008**

Related U.S. Application Data

(62) Division of application No. 10/624,389, filed on Jul. 22, 2003.

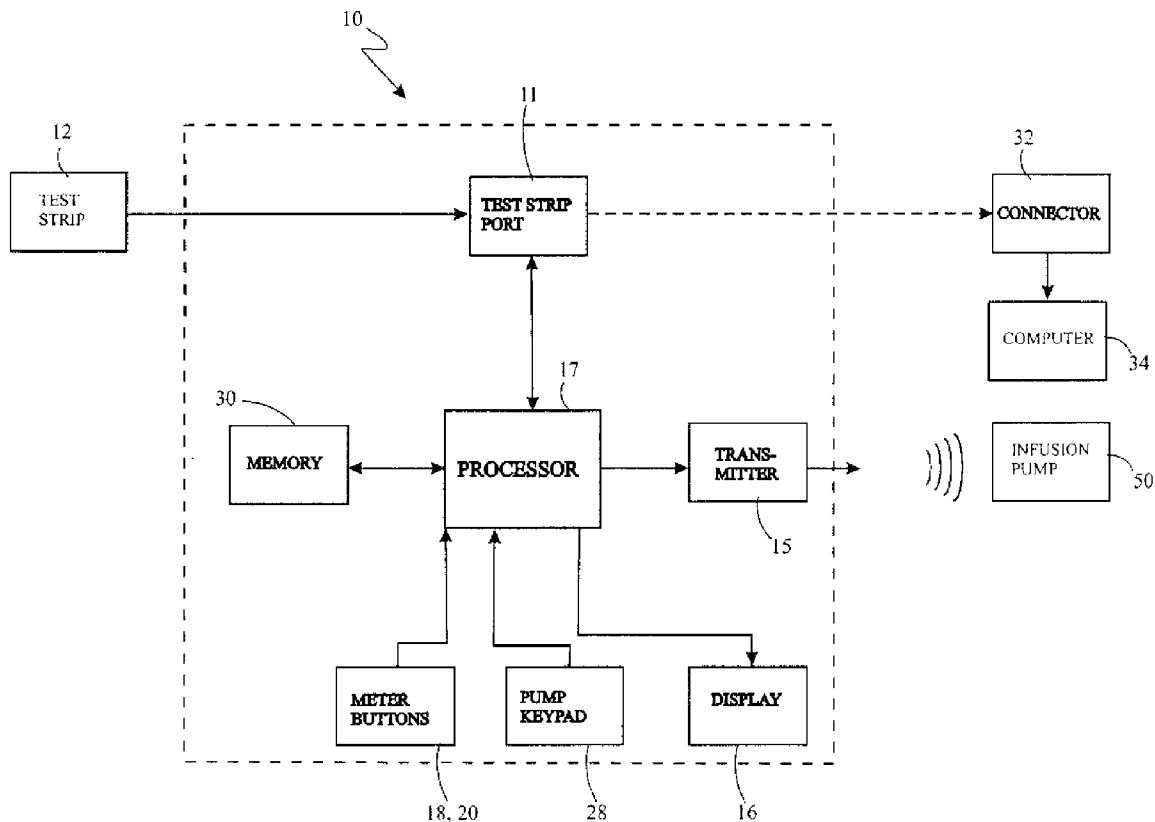

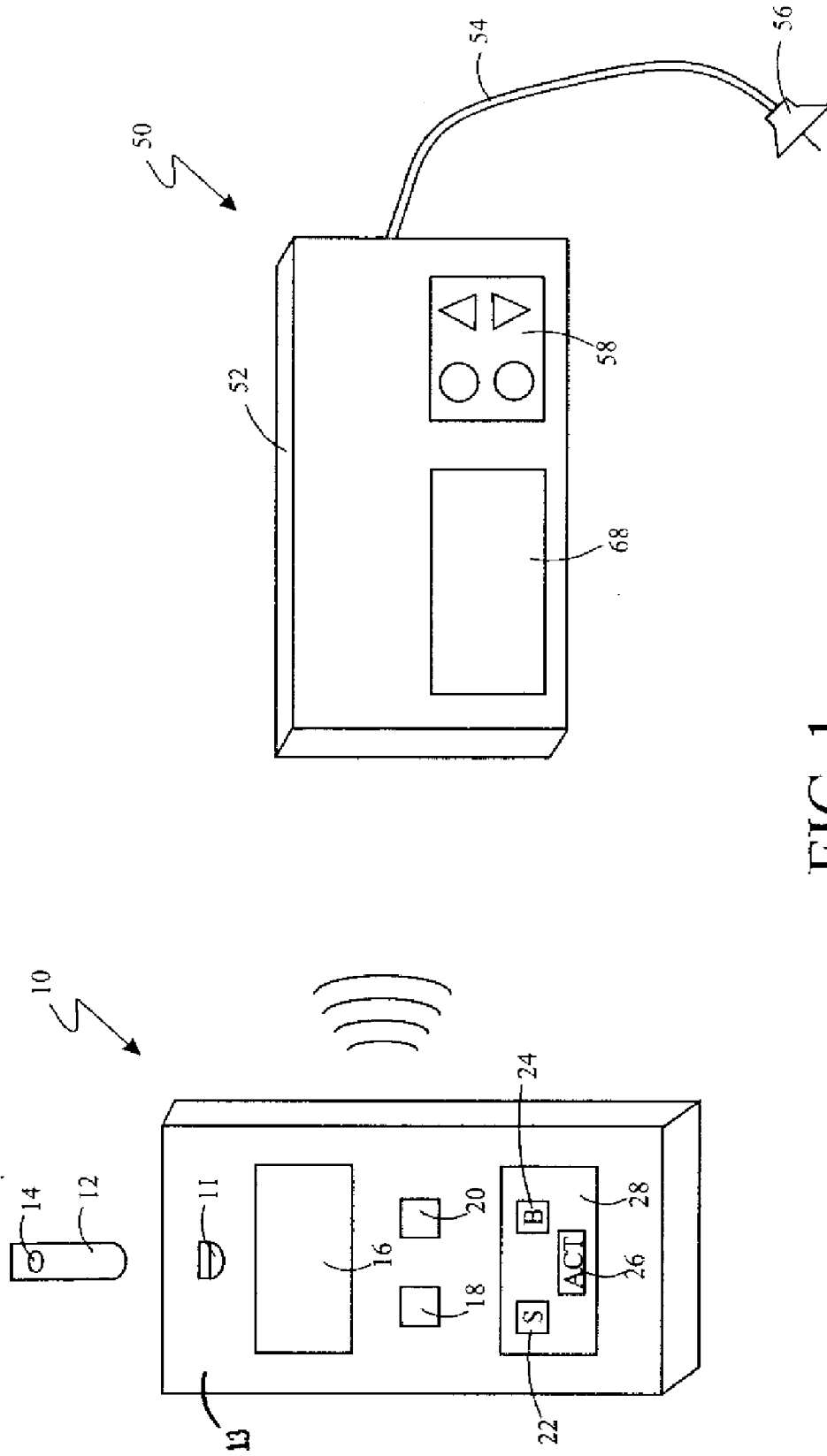

FIG. 1

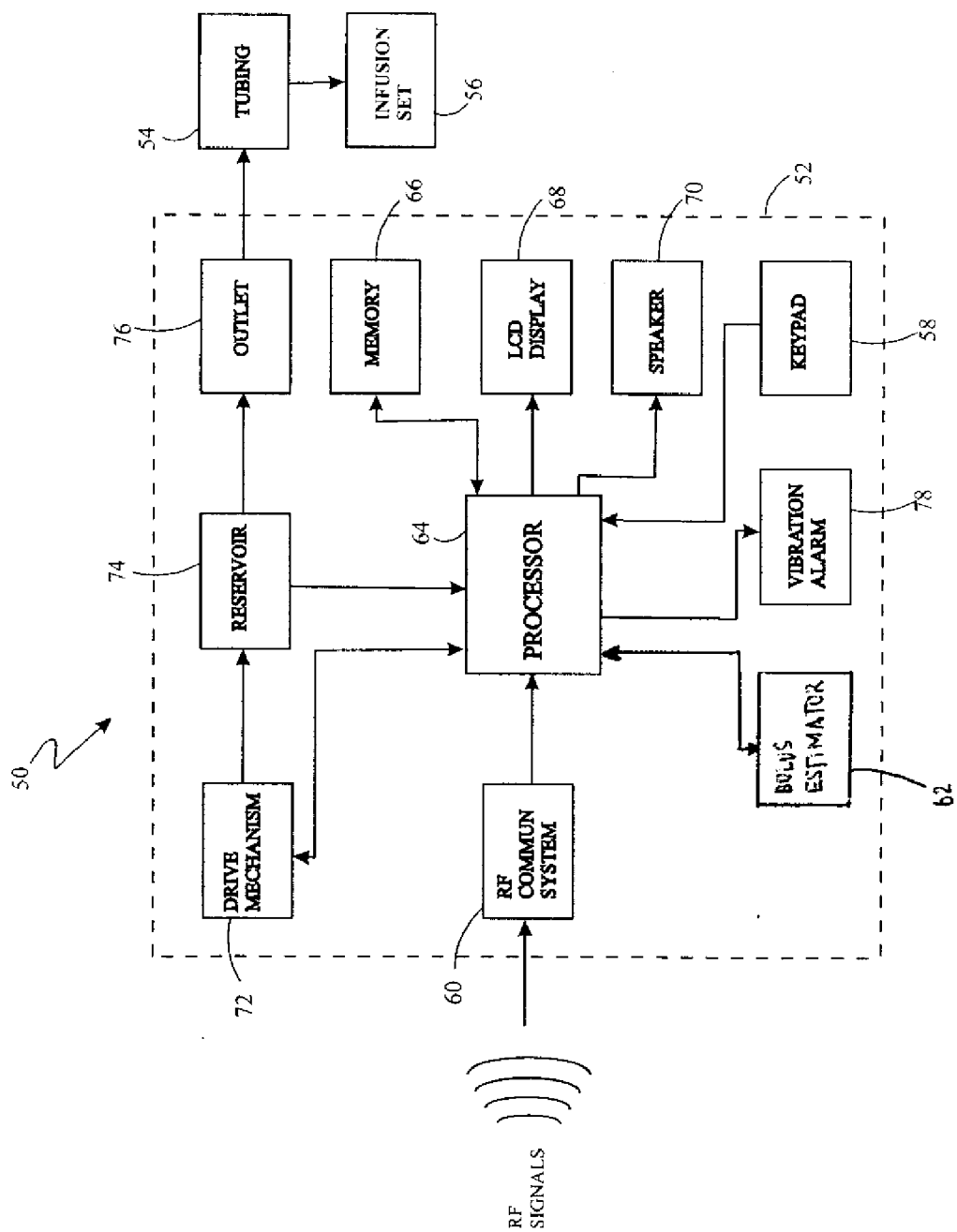

FIG. 2

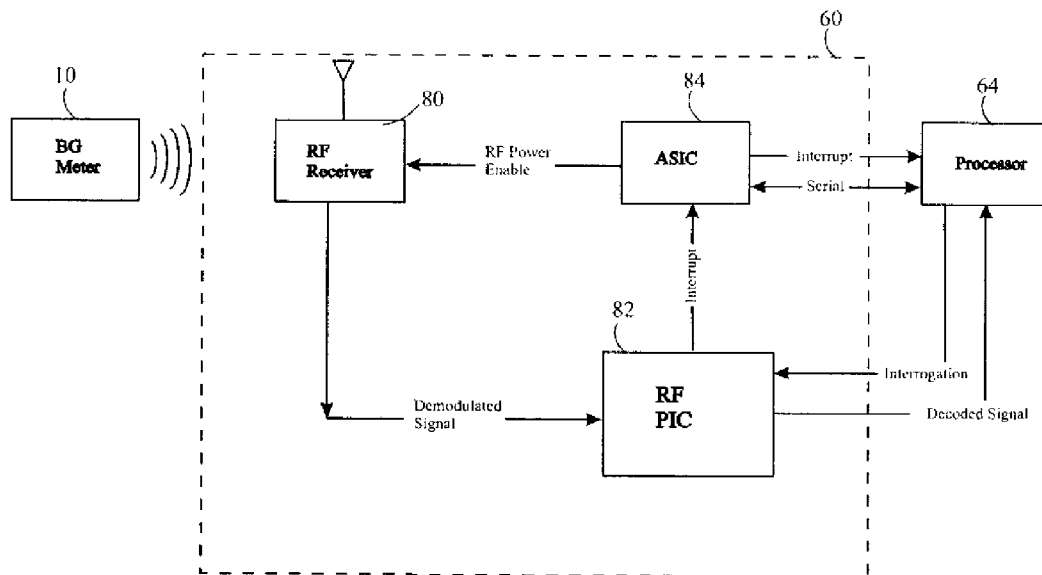

FIG. 3a

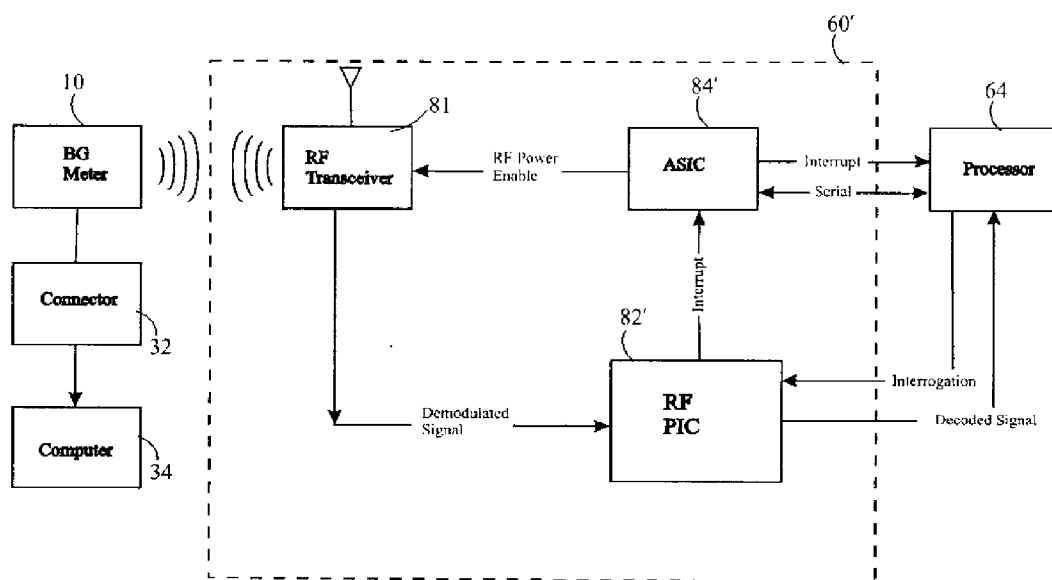

FIG. 3b

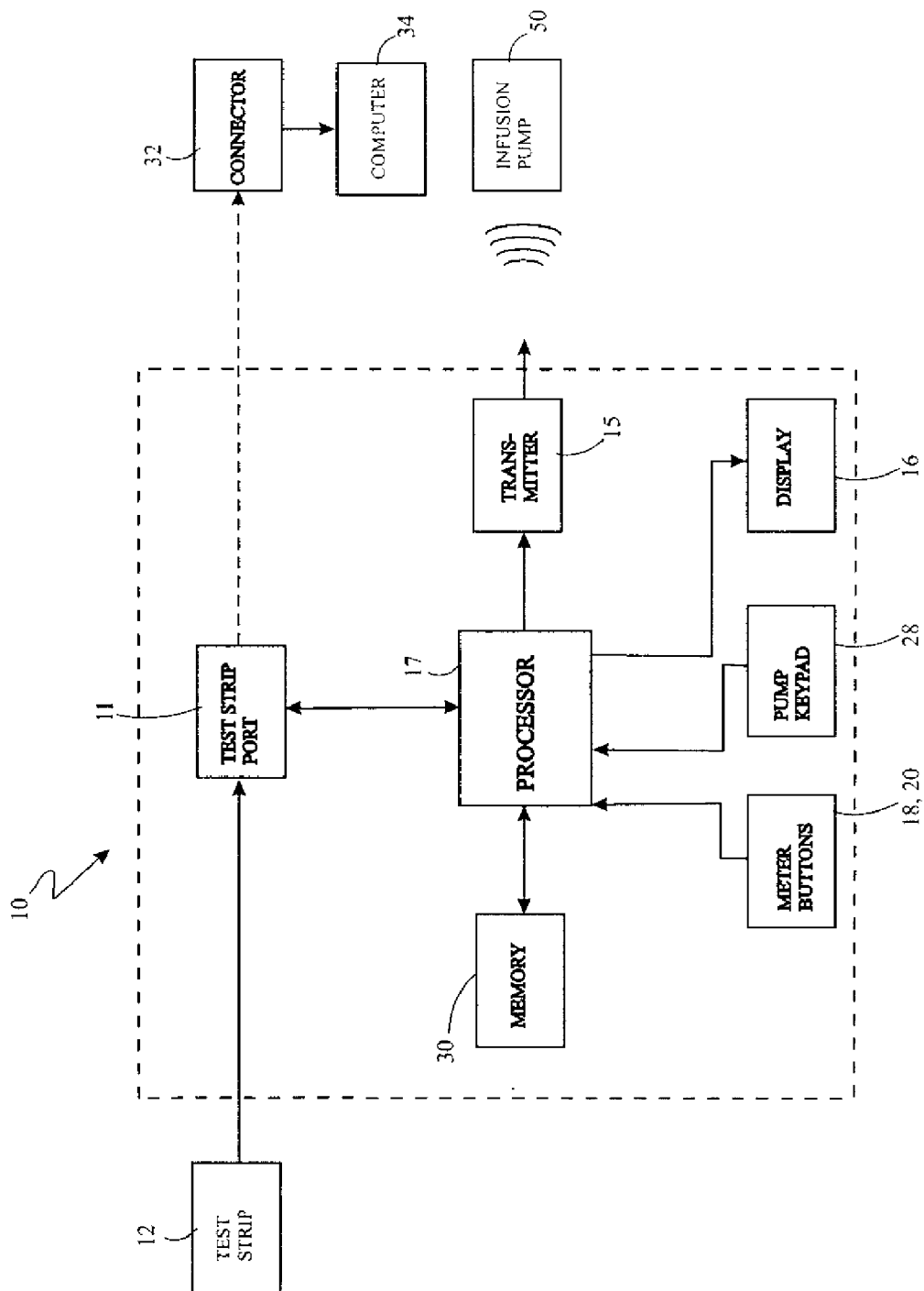

FIG. 4a

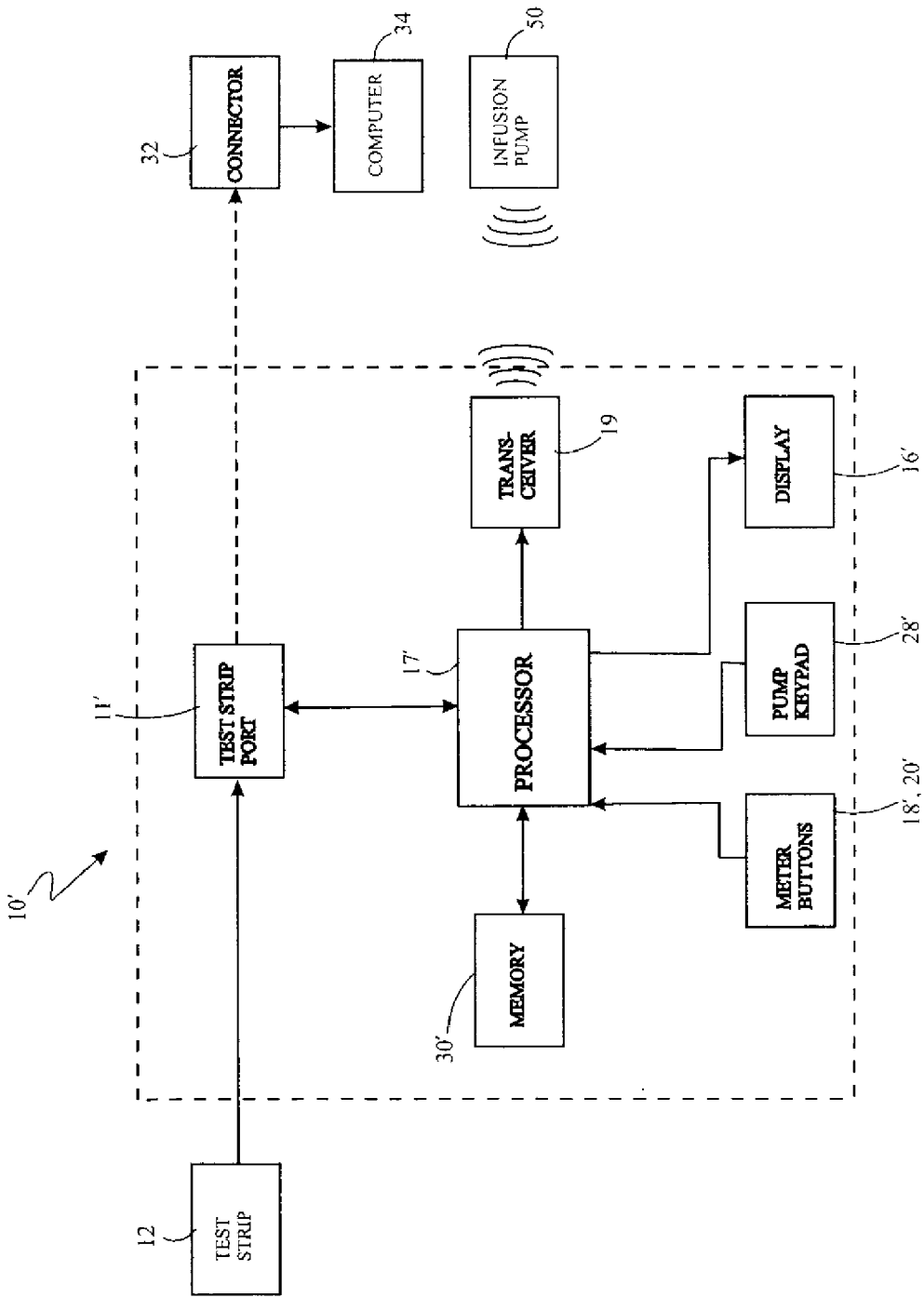

FIG. 4b

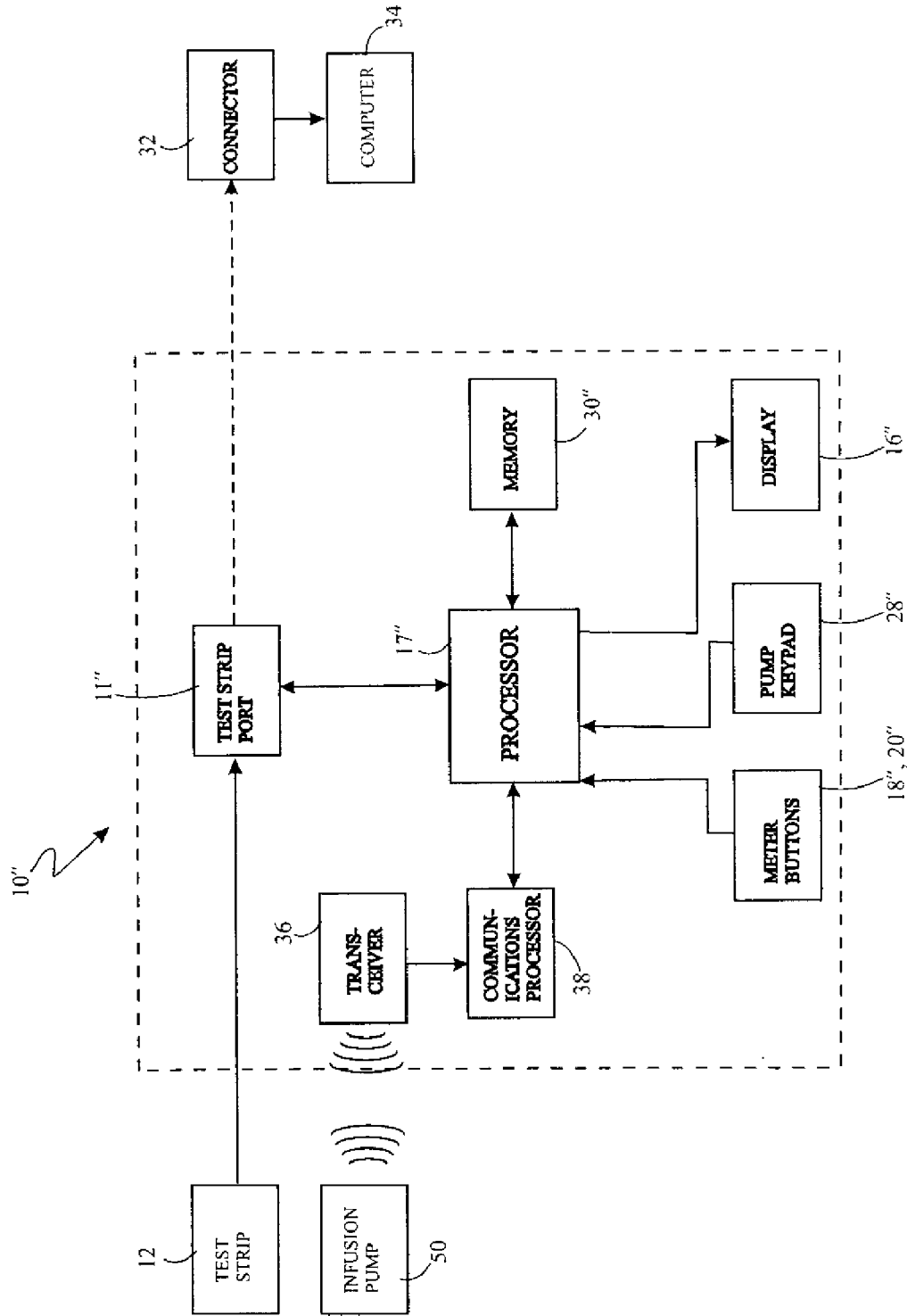

FIG. 5

**SYSTEM FOR PROVIDING BLOOD
GLUCOSE MEASUREMENTS TO AN
INFUSION DEVICE**

RELATED APPLICATIONS

[0001] This application claims priority from U.S. Provisional Applications No. 60/398,199 filed Jul. 24, 2002 and No. 60/412,998 filed Sep. 23, 2002, which are herein incorporated by reference.

FIELD OF THE INVENTION

[0002] This invention relates generally to infusion systems that are used for infusing a fluid into a user, and in particular, to apparatuses and methods for providing blood glucose measurements to an infusion device.

BACKGROUND OF THE INVENTION

[0003] Patients with Type 1 diabetes and some patients with Type 2 diabetes use insulin to control their blood glucose (BG) level. Typically, if a patient's BG level is too high, the patient can inject a "bolus" (dose) of insulin to lower his/her BG level from its present level to a desired target level. Furthermore, patients may inject a bolus of insulin in anticipation of ingesting carbohydrates, thus heading off a sharp rise in their BG level. Patients employ various calculations to determine the amount of insulin to inject. Bolus estimation software is available for calculating an insulin bolus. Patients may use these software programs on an electronic computing device, such as a computer, the Internet, a personal digital assistant (PDA), or an insulin delivery device. Insulin delivery devices include infusion pumps, injection pens, and IV meters. The best bolus estimation software takes into account the patient's present BG level. Presently, a patient must measure his/her blood glucose using a BG measurement device, such as a test strip meter, a continuous glucose measurement system, or a hospital hemacue. BG measurement devices use various methods to measure the BG level of a patient, such as a sample of the patient's blood, a sensor in contact with a bodily fluid, an optical sensor, an enzymatic sensor, or a fluorescent sensor. When the BG measurement device has generated a BG measurement, the measurement is displayed on the BG measurement device. Then the patient may visually read the BG measurement and physically enter the BG measurement into an electronic computing device to calculate a bolus estimate. Finally, once the bolus estimate is calculated, the patient must inject the insulin bolus or program an insulin delivery device to deliver the bolus into their body. Unfortunately, this process is cumbersome and is subject to transcribing errors—for example, the patient may inaccurately enter the BG measurement that is displayed on the BG measurement device into the electronic computing device. Thus, if the BG measurement is not entered correctly, the bolus estimate is not accurate, which may lead to the delivery of an inappropriate insulin dose.

SUMMARY OF THE INVENTION

[0004] In preferred embodiments of the present invention, an infusion system for infusing a fluid into a body of a user includes a characteristic determining device and an infusion device. The characteristic determining device includes a housing adapted to be carried by the user, a receptacle coupled to the housing for receiving and testing an analyte from the user to determine a concentration of the analyte in

the user, a processor contained in the housing and coupled to the receptacle for processing the determined concentration of the analyte from the receptacle, and a communication system contained in the housing and coupled to the processor for transmitting a communication including data indicative of the determined concentration of the analyte in the user. In particular embodiments, the characteristic determining device may also include a lancing device coupled to the receptacle for obtaining the analyte from the user. In preferred embodiments, the infusion device includes a housing adapted to be carried by the user, a drive mechanism contained in the housing and operatively coupled with a reservoir containing the fluid for infusing the fluid into the body of the user, a communication system contained in the housing for receiving the communication including the data indicative of the determined concentration of the analyte in the user from the determining device, and a processor contained in the housing and coupled to the communication system for processing the data indicative of the determined concentration of the analyte in the user and controlling the infusion device. The infusion device further includes a bolus estimator used in conjunction with the processor for calculating an estimated amount of fluid to be infused into the body of the user based upon the received data indicative of the determined concentration of the analyte in the user and a target concentration of the analyte in the user, and an indicator to indicate when the estimated amount of fluid to be infused has been calculated. Additionally, the infusion device may include a user input device for inputting an estimate of a material to be ingested by the user, and the bolus estimator may include the capability to calculate the estimated amount of fluid to be infused into the body of the user based upon the inputted estimate of the material to be ingested by the user. The infusion device may also include a memory for storing the data indicative of the determined concentration of the analyte in the user received by the infusion device communication system from the determining device communication system.

[0005] In particular embodiments, the characteristic determining device automatically transmits the communication including the data indicative of the determined concentration of the analyte in the user to the infusion device. In other particular embodiments, the characteristic determining device further includes a user input device for inputting commands, and transmits the communication including the data indicative of the determined concentration of the analyte in the user to the infusion device in response to a command from the user input device. In additional embodiments, the characteristic determining device further includes an indicator to indicate a status of the communication including the data indicative of the determined concentration of the analyte in the user being transmitted from the determining device communication system to the infusion device communication system.

[0006] In some embodiments, the communication transmitted from the characteristic determining device to the infusion device further includes a time at which the concentration of the analyte in the user was determined. In additional embodiments, the processor of the characteristic determining device determines an amount of time that has elapsed since the concentration of the analyte in the user was determined, and the communication transmitted from the determining device to the infusion device further includes the elapsed amount of time. Further, the processor of the characteristic determining device may cause the communication system of

the characteristic determining device not to transmit the communication including the data indicative of the determined concentration of the analyte in the user if the elapsed amount of time exceeds a predetermined amount of time. In other embodiments, the infusion device processor determines an amount of time that has elapsed since the data indicative of the determined concentration of the analyte in the user was received, and causes the bolus estimator not to calculate the estimated amount of fluid to be infused based upon the determined concentration of the analyte if the elapsed amount of time exceeds a predetermined amount of time. In still other embodiments, the processor of the infusion device determines an amount of time that has elapsed since the concentration of the analyte in the user was determined, and causes the bolus estimator not to calculate the estimated amount of fluid to be infused based upon the determined concentration of the analyte if the elapsed amount of time exceeds a predetermined amount of time.

[0007] In further embodiments, the determining device communication system is capable of being deactivated and reactivated. The characteristic determining device includes a user input device for inputting commands, and the communication system of the characteristic determining device is capable of being deactivated in response to a first command from the user input device and being reactivated in response to a second command from the user input device. Alternatively, the communication system of the characteristic determining device may be automatically reactivated after a predetermined amount of time has elapsed or at a predetermined time of day. Additionally, the characteristic determining device may include a memory for storing data indicative of the determined concentration of the analyte in the user that is determined when the determining device communication system is deactivated, and the determining device communication system may transmit a communication including the stored data to the infusion device communication system when the determining device communication system is reactivated.

[0008] In still other embodiments, the processor of the characteristic determining device has unique identification information, and the communication transmitted from the characteristic determining device to the infusion device further includes the unique identification information of the determining device processor such that the infusion device is capable of discerning whether the communication is intended for receipt by the infusion device. In yet other embodiments, the processor of the infusion device has unique identification information, and the communication transmitted from the characteristic determining device to the infusion device further includes the unique identification information of the infusion device processor such that the infusion device is capable of discerning whether the communication is intended for receipt by the infusion device.

[0009] In preferred embodiments, the processor of the infusion device uses power cycling whereby power is periodically supplied to the communication system of the infusion device until a communication is received from the characteristic determining device. When a communication is received from the characteristic determining device, the processor of the infusion device discontinues using power cycling whereby the power is continuously supplied to the infusion device communication system. The infusion device processor may then resume using power cycling upon completing the receipt of the communication including the data indicative of the

determined concentration of the analyte in the user from the determining device communication system.

[0010] In particular embodiments, the infusion system further includes a connector for coupling the characteristic determining device to a computer and downloading data from the characteristic determining device to the computer. The communication system of the infusion device is further capable of transmitting a communication including infusion device data to be downloaded, and the communication system of the characteristic determining device is further capable of receiving the communication including the infusion device data to be downloaded from the infusion device. The received infusion device data is then downloaded from the characteristic determining device through the connector to the computer. Alternatively, the characteristic determining device may further include a memory for storing data, and the received infusion device data may be stored in the memory of the characteristic determining device for subsequent downloading through the connector to the computer.

[0011] In other particular embodiments, the characteristic determining device further includes a user input device for inputting remote control commands for controlling the infusion device. The communication system of the characteristic determining device further transmits a communication including the remote control commands, and the communication system of the infusion device further receives the communication including the remote control commands from the characteristic determining device. The processor of the infusion device then controls the infusion device in accordance with the received remote control commands.

[0012] In yet other particular embodiments, the infusion device further includes a user input device for inputting remote control commands for controlling the characteristic determining device. The communication system of the infusion device further transmits a communication including the remote control commands, and the communication system of the characteristic determining device further receives the communication including the remote control commands from the infusion device. The processor of the characteristic determining device then controls the characteristic determining device in accordance with the received remote control commands.

[0013] In additional embodiments, the characteristic determining device further includes a determining device clock, and the infusion device further includes an infusion device clock. The infusion device communication system further transmits a communication including a time of the infusion device clock, and the determining device communication system further receives the communication including the time of the infusion device clock from the infusion device communication system. The determining device clock is then set to the received time of the infusion device clock. Alternatively, the determining device communication system further transmits a communication including a time of the determining device clock, and the infusion device communication system further receives the communication including the time of the determining device clock from the determining device communication system. The infusion device clock is then set to the received time of the determining device clock.

[0014] In accordance with another embodiment of the present invention, an infusion device infuses a fluid into a body of a user and is capable of communicating with a characteristic determining device, which is adapted for determining a concentration of an analyte in the user. The infusion

device includes a housing adapted to be carried by the user, a drive mechanism contained in the housing and operatively coupled with a reservoir containing the fluid for infusing the fluid into the body of the user, a communication system contained in the housing for receiving a communication including data indicative of the determined concentration of the analyte in the user from the characteristic determining device, and a processor contained in the housing and coupled to the communication system for processing the data indicative of the determined concentration of the analyte in the user and controlling the infusion device. The infusion device also includes a bolus estimator used in conjunction with the processor for calculating an estimated amount of fluid to be infused into the body of the user based upon the received data indicative of the determined concentration of the analyte in the user and a target concentration of the analyte in the user. The infusion device further includes an indicator to indicate when the estimated amount of fluid to be infused has been calculated.

[0015] In accordance with still another embodiment of the present invention, a characteristic determining device determines a concentration of an analyte in a body of a user and is capable of communicating with an infusion device, which is adapted for infusing a fluid into the body of the user and calculating an estimated amount of the fluid to be infused into the body of the user based upon the determined concentration of the analyte in the user and a target concentration of the analyte in the user. The characteristic determining device includes a housing adapted to be carried by the user, a receptacle coupled to the housing for receiving and testing an analyte from the user to determine the concentration of the analyte in the user, a processor contained in the housing and coupled to the receptacle for processing the determined concentration of the analyte from the receptacle, and a communication system contained in the housing and coupled to the processor for transmitting a communication including data indicative of the determined concentration of the analyte in the user to the infusion device.

[0016] According to yet another embodiment of the present invention, an infusion system includes a characteristic determining device and an infusion device, and a method for infusing a fluid into a body of a user is provided. The method includes the steps of: receiving and testing an analyte from the user to determine a concentration of the analyte in the user, transmitting with the characteristic determining device a communication including data indicative of the determined concentration of the analyte in the user, and receiving with the infusion device the communication including the data indicative of the determined concentration of the analyte in the user. The data indicative of the determined concentration of the analyte in the user received by the infusion device from the characteristic determining device may then be stored in a memory of the infusion device. The method further includes the steps of calculating an estimated amount of fluid to be infused into the body of the user based upon the received data indicative of the determined concentration of the analyte in the user and a target concentration of the analyte in the user, and indicating when the estimated amount of fluid to be infused has been calculated. Additionally, the method may include the step of inputting an estimate of a material to be ingested by the user, and the estimated amount of fluid to be infused into the body of the user is calculated further based upon the inputted estimate of the material to be ingested by the user.

[0017] In some embodiments, the communication including the data indicative of the determined concentration of the analyte in the user is automatically transmitted from the characteristic determining device to the infusion device. In other embodiments, the communication including the data indicative of the determined concentration of the analyte in the user is transmitted from the characteristic determining device to the infusion device in response to an inputted command. In still other embodiments, the system indicates a status of the communication including the data indicative of the determined concentration of the analyte in the user being transmitted from the characteristic determining device to the infusion device.

[0018] In particular embodiments, the communication including the data indicative of the determined concentration of the analyte in the user transmitted from the characteristic determining device to the infusion device further includes a time at which the concentration of the analyte in the user was determined. In other particular embodiments, the system also determines an amount of time that has elapsed since the concentration of the analyte in the user was determined. In yet other particular embodiments, the system determines an amount of time that has elapsed since the communication including the data indicative of the determined concentration of the analyte in the user was received by the infusion device.

[0019] In additional embodiments, the method further includes the steps of transmitting with the infusion device a communication including a clock time of the infusion device, receiving with the characteristic determining device the communication including the clock time of the infusion device, and setting a clock time of the characteristic determining device to the received clock time of the infusion device. Alternatively, the method may include the steps of transmitting with the characteristic determining device a communication including a clock time of the characteristic determining device, receiving with the infusion device the communication including the clock time of the characteristic determining device, and setting a clock time of the infusion device to the received clock time of the characteristic determining device.

[0020] In accordance with a further embodiment of the present invention, an infusion system for infusing a fluid into a body of a user includes a characteristic determining device and an infusion device. The characteristic determining device includes a determining device housing adapted to be carried by the user, a sensor coupled to the determining device housing for determining a concentration of an analyte in the user, a determining device processor contained in the determining device housing and coupled to the sensor for processing the determined concentration of the analyte from the sensor, and a determining device communication system contained in the determining device housing and coupled to the determining device processor for transmitting a communication including data indicative of the determined concentration of the analyte in the user. The infusion device includes an infusion device housing adapted to be carried by the user, a drive mechanism contained in the infusion device housing and operatively coupled with a reservoir containing the fluid for infusing the fluid into the body of the user, an infusion device communication system contained in the infusion device housing for receiving the communication including the data indicative of the determined concentration of the analyte in the user from the determining device communication system, and an infusion device processor contained in the infusion device hous-

ing and coupled to the infusion device communication system for processing the data indicative of the determined concentration of the analyte in the user and controlling the infusion device.

[0021] In particular embodiments, the determining device communication system automatically transmits the communication including the data indicative of the determined concentration of the analyte in the user to the infusion device communication system. In other particular embodiments, the characteristic determining device further includes a user input device for inputting commands, and the determining device communication system transmits the communication including the data indicative of the determined concentration of the analyte in the user to the infusion device communication system in response to a command from the user input device. In further particular embodiments, the characteristic determining device includes an indicator to indicate a status of the communication including the data indicative of the determined concentration of the analyte in the user being transmitted from the determining device communication system to the infusion device communication system.

[0022] In some embodiments, the infusion device further includes a bolus estimator used in conjunction with the infusion device processor for calculating an estimated amount of fluid to be infused into the body of the user based upon the received data indicative of the determined concentration of the analyte in the user and a target concentration of the analyte in the user. The infusion device also includes an infusion device indicator to indicate when the estimated amount of fluid to be infused has been calculated. In other embodiments, the infusion device further includes a memory for storing data, and the data indicative of the determined concentration of the analyte in the user received by the infusion device communication system from the determining device communication system is stored in the memory of the infusion device.

[0023] In additional embodiments, the determining device processor has unique identification information, and the communication transmitted from the determining device communication system to the infusion device communication system further includes the unique identification information of the determining device processor such that the infusion device is capable of discerning whether the communication is intended for receipt by the infusion device. In yet additional embodiments, the infusion device processor has unique identification information, and the communication transmitted from the determining device communication system to the infusion device communication system further includes the unique identification information of the infusion device processor such that the infusion device is capable of discerning whether the communication is intended for receipt by the infusion device.

[0024] In further embodiments, the determining device communication system is capable of being deactivated and reactivated. The characteristic determining device may also include a memory for storing data indicative of the determined concentration of the analyte in the user that is determined when the determining device communication system is deactivated. The determining device communication system then transmits a communication including the stored data to the infusion device communication system when the determining device communication system is reactivated.

[0025] In still further embodiments, the infusion device processor uses power cycling whereby power is periodically

supplied to the infusion device communication system until a communication is received from the determining device communication system. The infusion device processor discontinues using power cycling whereby the power is continuously supplied to the infusion device communication system when the communication including the data indicative of the determined concentration of the analyte in the user is received from the determining device communication system. Further, the infusion device processor resumes using power cycling upon completing the receipt of the communication including the data indicative of the determined concentration of the analyte in the user from the determining device communication system.

[0026] In other embodiments, the infusion system further includes a connector for coupling the characteristic determining device to a computer and downloading data from the characteristic determining device to the computer. The infusion device communication system is further capable of transmitting a communication including infusion device data to be downloaded, and the determining device communication system is further capable of receiving the communication including the infusion device data to be downloaded from the infusion device communication system. The received infusion device data is then downloaded from the characteristic determining device through the connector to the computer.

[0027] In yet other embodiments, the characteristic determining device further includes a determining device clock, and the infusion device further includes an infusion device clock. The infusion device communication system further transmits a communication including a time of the infusion device clock, and the determining device communication system further receives the communication including the time of the infusion device clock from the infusion device communication system. The determining device clock is then set to the received time of the infusion device clock. Alternatively, the determining device communication system further transmits a communication including a time of the determining device clock, and the infusion device communication system further receives the communication including the time of the determining device clock from the determining device communication system. The infusion device clock is then set to the received time of the determining device clock.

BRIEF DESCRIPTION OF THE DRAWINGS

[0028] A detailed description of embodiments of the invention will be made with reference to the accompanying drawings, wherein like numerals designate corresponding parts in the several figures.

[0029] FIG. 1 is a perspective view of a blood glucose meter and an infusion pump in accordance with an embodiment of the present invention.

[0030] FIG. 2 is a simplified block diagram of an infusion pump in accordance with an embodiment of the present invention.

[0031] FIG. 3(a) is a block diagram of an RF communication system in the infusion pump in accordance with an embodiment of the present invention.

[0032] FIG. 3(b) is a block diagram of an RF communication system in the infusion pump in accordance with another embodiment of the present invention.

[0033] FIG. 4(a) is a simplified block diagram of a blood glucose meter in accordance with an embodiment of the present invention.

[0034] FIG. 4(b) is a simplified block diagram of a blood glucose meter in accordance with another embodiment of the present invention.

[0035] FIG. 5 is a simplified block diagram of a blood glucose meter in accordance with still another embodiment of the present invention.

DETAILED DESCRIPTION OF THE PREFERRED EMBODIMENTS

[0036] As shown in the drawings for purposes of illustration, the invention is embodied in a system for communicating blood glucose measurements from a blood glucose measurement device to an electronic computing device, which utilizes the blood glucose measurements to calculate a bolus estimate. In preferred embodiments, the blood glucose (BG) measurement device is a blood glucose (BG) test strip meter, and the electronic computing device is an insulin delivery device, preferably an external insulin infusion pump. The BG meter utilizes a test strip with a sample of the user's blood to measure the user's BG level, and then transmits the BG measurement to the infusion pump using a communication system that includes, for example, a radio frequency (RF) transmitter or transceiver. The infusion pump receives the BG measurement from the BG meter, and includes bolus estimation software to calculate a bolus estimate using the received BG measurement. The infusion pump may then deliver a bolus amount to the user based on the calculated bolus estimate. Transmission of the BG measurement from the BG meter to the infusion pump eliminates user transcription errors (i.e., the user may not accurately enter the BG measurement into the infusion pump) and simplifies the use of a bolus estimator. In particular embodiments, the BG meter may also function as a remote controller for the infusion pump, so the user can initiate a bolus delivery (without the bolus estimator) or stop a bolus delivery using buttons located on the BG meter. The BG meter may further function as a communications link for downloading data from the infusion pump to a computer or the like.

[0037] However, in alternative embodiments of the present invention, the BG measurement device may be a continuous glucose measurement system, a hospital hemacue, an automated intermittent blood glucose measurement system, and the like, and/or the BG measurement device may use other methods for measuring the user's BG level, such as a sensor in contact with a body fluid, an optical sensor, an enzymatic sensor, a fluorescent sensor, a blood sample placed in a receptacle, or the like. In further alternative embodiments, the electronic computing device may be another type of insulin delivery device, such as an implantable insulin infusion pump or system that uses a combination of implantable and external components, an injection pen, an IV meter, and the like. In other alternative embodiments, the electronic computing device may be a computer, the Internet, a personal digital assistant (PDA), a portable telephone, a custom computing device, and the like. In still further alternative embodiments, the BG measurement device may use samples from body fluids other than blood, such as interstitial fluid, spinal fluid, saliva, urine, tears, sweat, or the like. In yet other alternative embodiments, other measurement devices may be utilized to determine the concentrations, levels, or quantities of other characteristics, analytes, or agents in the user, such as hormones, cholesterol, oxygen, pH, lactate, heart rate, respiratory rate, medication concentrations, viral loads (e.g., HIV), or the like. In still other alternative embodiments, other fluids

may be delivered to the user, such as medication other than insulin (e.g., HIV drugs, drugs to treat pulmonary hypertension, iron chelation drugs, pain medications, and anti-cancer treatments), chemicals, enzymes, antigens, hormones, vitamins, or the like. Particular embodiments are directed towards the use in humans; however, in alternative embodiments, the infusion devices may be used in animals.

[0038] In preferred embodiments of the present invention, a blood glucose (BG) measurement device measures a user's BG level and then communicates the BG measurement to an electronic computing device, which utilizes the BG measurement to calculate a bolus estimate. In the embodiment illustrated in FIG. 1, the BG measurement device is a BG test strip meter 10, and the electronic computing device is an insulin delivery device, preferably an external insulin infusion pump 50.

[0039] Referring to FIGS. 1 and 4(a), a housing 13 of the BG meter 10 preferably includes a test strip receptacle or port 11 for receiving and analyzing a test strip 12 or the like with a sample of the user's blood 14 on the test strip 12 to obtain a BG measurement. The BG meter 10 is adapted to be carried by the user, for example, in the hand, on the body, in a clothing pocket, attached to clothing (e.g., using a clip, strap, adhesive, or fastener), and the like. In particular embodiments, the user may utilize a separate lancing device (not shown) to obtain a blood sample, and then apply the sample onto the test strip 12. In other particular embodiments, the BG meter 10 may incorporate a lancing device (not shown) that obtains and automatically applies the blood sample onto the test strip 12.

[0040] In alternative embodiments, the BG measurement device may be a continuous glucose measurement system, a hospital hemacue, an automated intermittent blood glucose measurement system, and the like, and/or the BG measurement device may use other methods for measuring the user's BG level, such as a sensor in contact with a body fluid, an optical sensor, an enzymatic sensor, a fluorescent sensor, a blood sample placed in a receptacle, or the like. The BG measurement device may generally be of the type and/or include features disclosed in U.S. patent applications Ser. No. 09/377,472 filed Aug. 19, 1999 and entitled "Telemetered Characteristic Monitor System and Method of Using the Same," Ser. No. 09/334,996 filed Jun. 17, 1999 and entitled "Characteristic Monitor with a Characteristic Meter and Method of Using the Same," Ser. No. 09/487,423 filed Jan. 20, 2000 and entitled "Handheld Personal Data Assistant (PDA) with a Medical Device and Method of Using the Same," and Ser. No. 09/935,827 filed Aug. 23, 2001 and entitled "Handheld Personal Data Assistant (PDA) with a Medical Device and Method of Using the Same," which are herein incorporated by reference. Such BG measurement devices may be adapted to be carried by the user, for example, in the hand, on the body, in a clothing pocket, attached to clothing (e.g., using a clip, strap, adhesive, or fastener), and the like. In further alternative embodiments, the BG measurement device may use samples from body fluids other than blood, such as interstitial fluid, spinal fluid, saliva, urine, tears, sweat, or the like. In yet other alternative embodiments, other characteristic determining or measuring devices may be utilized to determine or measure the concentrations, levels, or quantities of other characteristics, analytes, or agents in the user, such as hormones, cholesterol, oxygen, pH, lactate, heart rate, respiratory rate, medication concentrations, viral loads (e.g., HIV), or the like.

[0041] In particular embodiments, once the BG meter **10** obtains a BG measurement, the BG measurement is transmitted to the infusion pump **50** using a communication system, which includes a radio frequency (RF) transmitter **15**, as will be described below. In other particular embodiments, the RF transmitter **15** may be replaced with an RF transceiver **19** (as shown in FIG. 4(b)) or **36** (as shown in FIG. 5), and the BG measurement may be transmitted to the infusion pump **50** using the RF transceiver **19** or **36**.

[0042] The test strip port **11** and RF transmitter **15** are coupled to a processor **17** contained in the housing **13** of the BG meter **10**. The processor **17** runs programs and controls the BG meter **10**, and is also connected to a memory **30** for storing programs, history data, user defined information and parameters, and the like. The BG meter **10** also preferably includes a display **16** for providing the BG measurement and/or messages, such as status or error messages, to the user. In particular embodiments, the display **16** may include a backlight for reading the display **16** in the dark.

[0043] In preferred embodiments, the BG meter **10** includes one or more buttons **18** and **20** for operation of the meter **10**, such as turning on/off the meter **10**, reviewing previous BG measurements, transmitting BG measurements to the infusion pump **50**, turning off the transmitter **15** (or transceiver **19** (shown in FIG. 4(b)) or **36** (shown in FIG. 5)) in the BG meter **10** so that it does not send a BG measurement to the infusion pump **50**, and the like. The BG meter **10** may further include a keypad **28** with one or more buttons **22**, **24**, and **26** that are preferably dedicated to remotely controlling the infusion pump **50**, for example, via the RF transmitter **15** (or RF transceiver **19** (as shown in FIG. 4(b)) or **36** (as shown in FIG. 5)), as will be described below. The buttons **22**, **24**, and **26** may also be used to transmit BG measurements to the infusion pump **50**. The buttons **22**, **24**, and **26** may be labeled 'S' for "suspend", 'B' for "bolus", and 'ACT' for "activate". In alternative embodiments, more or less buttons for operating the meter **10** and/or remotely controlling the infusion pump **50** may be included on the meter **10**, and the buttons may be labeled other than as illustrated in FIG. 1. For example, the BG meter **10** may include an additional button for operating a lancing device (not shown) that is incorporated into the meter **10**. In further alternative embodiments, the buttons **22**, **24**, and **26** may be omitted, and the buttons **18** and **20** may be used to remotely control the infusion pump **50**. In other alternative embodiments, the buttons **18** and **20** may be omitted, and the buttons **22**, **24**, and **26** may be used to operate the BG meter **10**, or alternatively, no buttons may be needed to operate the meter **10**. For example, the meter **10** may include no buttons or other user interface or input device, and may be controlled using an external device, such as a remote programmer (not shown), the infusion pump **50**, a PDA, or the like. In yet other alternative embodiments, one or more of the buttons **18**, **20**, **22**, **24**, and **26** may be omitted, and the user may utilize other input devices to interface with the BG meter **10**, such as selecting a menu item, utilizing the display **16** as a touch screen, pressing multi-function keys, or the like.

[0044] In addition to transmitting the BG measurement to the infusion pump **50**, the BG meter **10** also preferably stores the BG measurement in the memory **30** of the BG meter **10** for subsequent analysis and review. A history of alarms or error messages generated by the BG meter **10**, as well as remote control commands sent to and/or information received from the infusion pump **50**, may also be stored in the memory **30** of

the BG meter **10**. Further, the user may periodically cause the BG meter **10** to download the stored data through an interface (such as the RF transmitter **15** (or RF transceiver **19** (as shown in FIG. 4(b)) or **36** (as shown in FIG. 5)), a cable, a communication station, or the like), to a computer **34**, or alternatively, over the Internet to a remote server for storage. In particular embodiments, a connector **32** may be inserted into the test strip port **11** to provide a wired connection to a USB, serial, or the like port of the computer **34**, and data may be downloaded from the BG meter **10** through the connector **32** to the computer **34**. The user or a caregiver (e.g., the user's parent, health care professional, educator) can evaluate the user's therapy by accessing the historical BG measurements and insulin delivery information downloaded from the pump **50**, as will be described below.

[0045] In the embodiment illustrated in FIGS. 1 and 2, the electronic computing device is an insulin delivery device, preferably an external insulin infusion pump **50**. The infusion pump **50** regulates the flow of fluid from the infusion pump **50**, through a flexible tube **54**, and into an infusion set **56** or the like that is adhered to the individual. Infusion sets **56** that may be used as a delivery device are described in, but not limited to, U.S. Pat. Nos. 4,723,947; 4,755,173; 5,176,662; 5,584,813; and 6,056,718, which are herein incorporated by reference. The infusion pump **50** may be of the type described in U.S. Pat. Nos. 4,562,751; 4,685,903; 5,080,653; 5,097,122; 5,505,709; and 6,248,093; and disclosed in U.S. patent application Ser. No. 09/334,858 (attorney docket PD-0294), filed Jun. 17, 1999 and entitled "Infusion Pump With Remote Programming and Carbohydrate Calculator Capabilities," which are herein incorporated by reference. Such infusion pumps **50** may be adapted to be carried by the user, for example, in the hand, on the body, in a clothing pocket, attached to clothing (e.g., using a clip, strap, adhesive, or fastener), and the like. Alternatively, other infusion pumps **50** may be used for delivery of fluid through an infusion set **56** into an individual's body. In further alternative embodiments, devices other than infusion pumps **50** may be used for delivery of fluid into an individual's body, such as an implantable insulin infusion pump or system that uses a combination of implantable and external components, an injection pen, an IV meter, and the like. In other alternative embodiments, the electronic computing device may be a computer, the Internet, a personal digital assistant (PDA), a portable telephone, a custom computing device, and the like.

[0046] As illustrated in FIGS. 1 and 2, preferred embodiments of the infusion pump **50** include an RF communication system **60** and a bolus estimator **62**. In particular embodiments, the RF communication system **60** includes an RF receiver **80**, as shown in FIG. 3(a), which allows one-way communication from the BG meter **10** (or other external devices such as a remote programmer for the infusion pump **50**) to the infusion pump **50**. In other particular embodiments, the RF communication system **60** may include an RF transceiver **81**, as shown in FIG. 3(b), which allows two-way communication between the BG meter **10** (or other external devices such as a remote programmer for the infusion pump **50**) and the infusion pump **50**.

[0047] The RF communication system **60** and bolus estimator **62** communicate with a processor **64** contained in a housing **52** of the infusion pump **50**. The processor **64** is used to run programs and control the infusion pump **50**, and is connected to an internal memory device **66** that stores programs, history data, user defined information and parameters.

In preferred embodiments, the memory device **66** is a ROM and DRAM; however, in alternative embodiments, the memory device **66** may include other memory storage devices, such as RAM, EPROM, dynamic storage such as flash memory, energy efficient hard-drive, or the like. In the illustrated embodiment, the processor **64** is also coupled to a drive mechanism **72** that is connected to a fluid reservoir **74** containing fluid, which is delivered through an outlet **76** in the reservoir **74** and housing **52**, and then into the user's body through the tubing **54** and the infusion set **56**.

[0048] The infusion pump **50** is preferably programmed through a user input device such as a keypad **58** on the housing **52**, or alternatively, by commands received from an RF programmer (not shown) through the RF communication system **60**. The infusion pump **50** may also be programmed through the keypad **58** on the BG meter **10**, for example, through the RF communication system **60**, as will be described below. Feedback to the infusion pump **50** on status or programming changes are shown on a display **68**, audibly through a speaker **70**, and/or tactilely through a vibration alarm **78**. The infusion pump **50** may also provide the user with an alarm either audibly via the speaker **70** and/or tactilely via the vibration alarm **78**, such as a warning that is indicative of a low reservoir situation or low battery. Alarms may start out at a low level and escalate until acknowledged by the user. In alternative embodiments, the keypad **58** may include more or less keys or different key arrangements than those illustrated in FIG. 1. In further alternative embodiments, the keypad **58** may be omitted, and the display **68** may be used as a touch screen input device. In other alternative embodiments, the keypad **58**, display **68**, speaker **70**, and/or vibration alarm **78** may be omitted, and all programming and data transfer may be handled through the RF communication system **60**.

[0049] In particular embodiments, one-way communication is provided from the BG meter **10** to the infusion pump **50**. The BG meter **10** includes the RF transmitter **15** (shown in FIG. 4(a)), and the infusion pump **50** includes an RF receiver **80** (shown in FIG. 3(a)). In other particular embodiments, two-way communication is provided between the BG meter **10** and the infusion pump **50**. The RF transmitter **15** in the BG meter **10** is replaced with an RF transceiver **19** (shown in FIG. 4(b)) or **36** (shown in FIG. 5), and the RF receiver **80** in the infusion pump **50** is replaced with an RF transceiver **81** (shown in FIG. 3(b)).

[0050] The infusion pump **50** may provide several programming options, including the bolus estimator **62**, as well as remote and on-device programming. The infusion pump **50** may also be configured through an interface, such as a cable or communication station, using a computer or the like. Additionally, the infusion pump **50** may allow the user to download information in the memory **66** through the interface to a computer or the like, or alternatively, over the Internet to a remote server, for storage. Further description of a communication station of this general type may be found in U.S. Pat. No. 5,376,070, which is herein incorporated by reference. The user or a caregiver (e.g., the user's parent, health care professional, educator) can evaluate the user's therapy by accessing the historical BG measurements downloaded from the BG meter **10** and insulin delivery information downloaded from the pump **50**.

[0051] Information may also be downloaded from the infusion pump **50** through the RF communication system **60**. Referring to FIG. 3(b), the RF communication system **60**

may include the RF transceiver **81** for transmitting information to and receiving information from external devices. In particular embodiments, an external communication link (not shown) may be connected to a serial, USB, or the like port of a computer. Information may be transmitted from the RF transceiver **81** in the infusion pump **50** to an RF transceiver in the external communication link (not shown), which then downloads the information through a wired connection to the computer or the like. During the download process, the communication link may draw power from the computer through the serial, USB, or the like port. In other particular embodiments, the connector **32** may be inserted into the test strip port of the BG meter **10'** to provide a wired connection to a USB, serial, or the like port of the computer **34**, as shown in FIG. 4(b). Information may be transmitted from the RF transceiver **81** in the infusion pump **50** to the RF transceiver **19** in the BG meter **10'**, and may then be downloaded through the connector **32** to the computer **34**. The BG meter **10'** merely functions as a "pass through" connection between the infusion pump **50** and the computer **34**. During the download process, power may be drawn from the power supply (not shown) for the BG meter **10'** (e.g., battery or the like), or alternatively, from the USB, serial, or the like port of the computer **34**. In still other particular embodiments, information may be transmitted from the RF transceiver **81** in the infusion pump **50** to the RF transceiver **36** in the BG meter **10"**, as shown in FIG. 5. The information may be transmitted from the infusion pump **50** to the BG meter **10"** at a rate higher than can be handled by the meter processor **17"**. Accordingly, the BG meter **10"** may include a communications microcontroller or processor **38** with a higher processing speed (e.g., 10 MHz) than the meter processor **17"** with a lower processing speed (e.g., 1-4 MHz). The transmitted information is first processed by the communications processor **38**, then processed by the meter processor **17"**, and finally downloaded through the connector **32** to the computer **34**. Again, the BG meter **10'** merely functions as a "pass through" connection between the infusion pump **50** and the computer **34**. In alternative embodiments, information may be transmitted from the infusion pump **50** and stored in the memory **30'** or **30"** of the BG meter **10'** or **10"** for subsequent downloading from the BG meter **10'** or **10"** to the computer **34**. In further alternative embodiments, information may be transmitted from the infusion pump **50** through the BG meter to the computer **34** using other modes of communication, such as infrared, optical, or the like.

[0052] In preferred embodiments, the infusion pump **50** communicates with various external devices, such as the BG meter **10**, a remote programmer, and a communication station, using the RF communication system **60**, which will be described below. The infusion pump **50** also provides a confirmation to the user upon receipt of a communication from another device (e.g., the BG meter **10**). In particular embodiments, the infusion pump **50** provides one or more audible signals when it has received a communication. More than one audible signal may be used, and each audible signal indicates the type of communication that was received. For example, the infusion pump **50** may beep 4 times when it has received a communication to deliver 0.4 units of insulin in a bolus, provide a long low tone when it has received a communication to suspend insulin delivery, and/or sound off with a two-tone "door bell" sound when a new BG measurement has been communicated. In alternative embodiments, the infusion pump **50** may provide other forms of confirmation when a communication has been received, such as one or more

vibrations via the vibration alarm 78, messages on the display 68, lights or flashing lights, or the like.

[0053] In preferred embodiments, once the BG meter 10 obtains a BG measurement, the BG meter 10 automatically transmits the BG measurement to the infusion pump 50. In particular embodiments, the BG meter 10 analyzes the blood sample 14 on the test strip 12 to calculate a BG measurement and then transmits the BG measurement to the infusion pump 50 without additional effort by the user. In alternative embodiments, the BG measurement is transmitted when the test strip 12 is removed from the BG meter 10. In other alternative embodiments, the BG meter 10 transmits the BG measurement in response to an action by the user. The BG meter 10 may also retransmit the BG measurement to the infusion pump 50 in response to a user action, such as pressing a button, selecting a menu item, or holding down a button on the BG meter 10, aligning the BG meter 10 and the infusion pump 50, or the like. In alternative embodiments, the BG meter 10 is notified by the infusion pump 50 to transmit or retransmit the BG measurement.

[0054] Once the infusion pump 50 receives the BG measurement, the infusion pump 50 may provide an alarm or warning to the user if the received BG measurement is above or below glycemic limits. The glycemic limits are preferably programmable, such as 120 mg/dl for hyperglycemia and 60 mg/dl for hypoglycemia. The user, a caregiver, a physician, a parent, a guardian, a child, or the like may program other limits into the infusion pump 50. In alternative embodiments, the glycemic limits are not programmable. In preferred embodiments, the infusion pump 50 will suspend insulin delivery if the received BG measurement is below the hypoglycemic limit. The infusion pump 50 may also notify the user to activate a bolus delivery if the received BG measurement is above the hyperglycemic limit. In alternative embodiments, the infusion pump 50 does not compare the received BG measurement to glycemic limits, and does not suspend insulin delivery in the event of hypoglycemia or notify the user to activate bolus delivery in the event of hyperglycemia.

[0055] In preferred embodiments, the infusion pump 50 also stores the received BG measurement in its memory 66. Further, the bolus estimator 62 in the infusion pump 50 may utilize the received BG measurement to calculate a bolus estimate, either automatically or in response to user input, such as through the keypad 58, a remote programmer, or the like. Once the bolus estimate is calculated and provided to the user, for example, on the display 68, the user may then approve the recommended estimate for delivery into the body, modify the recommended estimate for delivery into the body, or reject the recommended estimate. The bolus estimator 62 may generally be of the type and/or include features disclosed in U.S. patent application Ser. No. 09/334,858 filed Jun. 16, 1999, now issued U.S. Pat. No. 6,554,798 issued Apr. 29, 2003.

[0056] The BG meter 10 preferably informs the user of the status of the BG measurement calculation and/or transmission. If the infusion pump 50 is capable of only one-way communication, such notification is preferable because no confirmation is received from the infusion pump 50 indicating that the transmitted data has been received by the pump 50. The BG meter 10 may notify the user when a blood sample is being analyzed to obtain a BG measurement. The BG meter 10 may also notify the user when the BG measurement is being transmitted to the infusion pump 50. The BG meter 10

may further notify the user when the transmission of the BG measurement is complete. Once notified that the transmission of the BG measurement is complete, the user may access the bolus estimator 62 in the infusion pump 50 to view the BG measurement and calculate a bolus. In preferred embodiments, the BG meter 10 displays the status on the display 16, for example, as an alphanumeric message, a graphical icon, or the like. In alternative embodiments, the status is communicated to the user in other ways, such as using one or more light emitting diodes, one or more audible tones, a speaker, a piezo electric device, a vibrator or other tactile device, or the like. In further alternative embodiments, the BG meter 10 may not provide the status to the user. For example, if the BG measurement device provides continuous or automatic intermittent BG measurements, the user is not perpetually notified regarding the status of the calculations and/or transmissions.

[0057] In preferred embodiments, the BG meter 10 keeps track of the elapsed time between when a BG measurement is collected and when it is communicated to the infusion pump 50 for calculating a bolus estimate. A BG measurement is preferably used to calculate a bolus estimate only if the BG measurement is recent enough. The bolus estimation is at least partially dependent on the difference between the user's present BG level and a desired target BG level. Since a user's BG level varies over time, using an old BG measurement to calculate a bolus estimation might result in a bolus estimation that is inappropriate for the user. A BG measurement is expired (and is not used for bolus estimation) when it is too old to be considered representative of the user's present BG level. The BG meter 10 does not transmit a BG measurement to the infusion pump 50 for use in a bolus estimation calculation if the BG measurement is expired. The BG meter 10 may also indicate to the user that a new BG measurement is required because the BG measurement is expired or unavailable. In preferred embodiments, the BG measurement expires at 10 minutes. In alternative embodiments, the BG measurement may expire in an amount of time greater or less than 10 minutes, such as 5 or 7 minutes, 15 or 30 minutes, 1 hour, or the like. In further alternative embodiments, the time required for a BG measurement to expire may be set by the user, a caregiver, a physician, a parent, a guardian, a child, and the like. For example, a child's BG level may change more quickly than that of a heavy adult, so the BG meter 10 may be set so that BG measurements older than 5 minutes cannot be communicated to the infusion pump 50 for use in a bolus estimation. To continue the example, an adult might program the BG meter 10 so that BG measurements expire after 12 minutes. Furthermore, the time required for a BG measurement to expire may be set depending on the time of the user's most recent bolus dose of medication. A first period may be set if the user has taken a bolus within a specified duration of time, and a second period may be set if the user has not taken a bolus within the specified duration of time. For example, the time required for a BG measurement to expire may be set to 5 minutes if the user has taken a bolus within the past 2 hours, and to 15 minutes if the user has not taken a bolus within the past 2 hours.

[0058] In preferred embodiments, the infusion pump 50 does not use an expired BG measurement in a bolus estimation calculation. The infusion pump 50 preferably keeps track of the time between when a new BG measurement is received from the BG meter 10 and when the new BG measurement is used in a bolus estimation calculation. In particular embodiments, once the BG meter 10 obtains a BG measurement, the

BG measurement is immediately transmitted to the infusion pump **50**, either automatically or in response to a user action. Thus, when the infusion pump **50** receives a BG measurement, the pump **50** knows that the BG measurement was recent, and can calculate the approximate age of the BG measurement simply by determining the amount of time that has elapsed between when the BG measurement was received from the BG meter **10** and when the BG measurement is used in a bolus estimation calculation. In other particular embodiments, the infusion pump **50** is told the age of the BG measurements it receives. In other words, the elapsed time between when a BG measurement is collected and when it is communicated to the infusion pump **50** is transmitted along with each BG measurement. Then, the infusion pump **50** can calculate the age of the BG measurement by adding the age of BG measurement at the time it was transmitted to the time that has passed since the BG measurement was received. Since the infusion pump **50** knows the age of the BG measurement, the infusion pump **50** can eliminate BG measurements that are expired and/or prevent expired BG measurements from being used in a bolus estimation calculation. In particular embodiments, the infusion pump **50** will request a new BG measurement from the user when the user attempts to use a bolus estimator and the BG measurement is expired or unavailable.

[0059] In alternative embodiments, an estimate of the user's BG level is used for bolus estimation. In particular alternative embodiments, the user's BG level is estimated using the last BG measurement, the age of the BG measurement, the amount of insulin that has been delivered, the insulin action time, the number of carbohydrates consumed, the carbohydrate/insulin ratio, and the like. In further alternative embodiments, the estimate of the user's BG level will expire if not used soon enough. In still further alternative embodiments, the estimate of the user's BG level may only be calculated for a certain period after a BG measurement is collected. In other alternative embodiments, the length of time that a BG estimate may be calculated since a BG measurement was collected is determined by the amount of insulin that has been delivered, the amount of carbohydrates the user has ingested, the user's insulin sensitivity, and/or by the user's insulin action time. For example, estimates of BG levels may be calculated for a longer period if the user has not eaten lately and is using only basal insulin. If the user has eaten or taken a bolus of insulin, then the period of time that an estimate of the user's BG level might be calculated is shorter.

[0060] In preferred embodiments, the BG meter **10** communicates with the infusion pump **50** using RF communication. In alternative embodiments, other modes of communication may be used, such as infrared (IR), wired, ultrasonic, sonic, optical, and the like. The BG meter **10** transmits one or more BG measurements to the infusion pump **50**. The BG meter **10** may also communicate one or more remote control commands to the infusion pump **50**. The available commands preferably include a bolus amount of insulin, a command to begin insulin delivery, and a command to suspend insulin delivery. In alternative embodiments, more or less remote control commands may be provided between the BG meter **10** and the infusion pump **50**. The RF transmitter **15** (or RF transceiver **19** (as shown in FIG. 4(b)) or **36** (as shown in FIG. 5)) in the BG meter **10** transmits the data (e.g., BG measurements or remote control commands) to the RF communication system **60** in the infusion pump **50**. Additionally, the infusion pump **50** may communicate one or more user-defined parameters to the BG meter **10** (e.g., the time required

for a BG measurement to expire). The RF transceiver **81** in the infusion pump **50** (shown in FIG. 3(b)) transmits such parameters to the RF transceiver **19** (as shown in FIG. 4(b)) or **36** (as shown in FIG. 5) in the BG meter **10** or **10'**.

[0061] In preferred embodiments, communication between the BG meter **10** and the infusion pump **50** contains unique identifying information about the BG meter **10** and/or infusion pump **50**, such as the BG meter's **10** and/or infusion pump's **50** serial number, identification number, a password, a code, or the like. In particular embodiments, the unique identifying information about the BG meter **10** and/or infusion pump **50** included in the communication between the BG meter **10** and the infusion pump **50** is used by the respective devices (i.e., BG meter **10** and/or infusion pump **50**) to discern between communications that are intended for the device and those that are not. In alternative embodiments, other codes may be included in communications between the BG meter **10** and the infusion pump **50** that are used by the respective devices to recognize which communications are intended for the device, such as an identification code for the device, a password, a bit sequence, a special frequency, timing between communications, or the like.

[0062] In preferred embodiments, the communication system in the BG meter **10** may be deactivated, preferably by the user. When the communication system is deactivated, the BG meter **10** will not attempt to communicate with other devices, including the infusion pump **50**. For example, when a new BG measurement is available, the BG meter **10** will not communicate the BG measurement to another device, such as the infusion pump **50**. In particular embodiments, the BG meter **10** includes an RF transmitter **15** (shown in FIG. 4(a)) (or RF transceiver **19** (shown in FIG. 4(b)) or **36** (shown in FIG. 5)) that can be deactivated and reactivated by the user. This is especially useful if the BG meter **10** transmits at frequencies that might disrupt an airplane during take-off. In alternative embodiments, other devices may be used to deactivate and reactivate the communication system in the BG meter **10**, such as the infusion pump **50**, other insulin delivery device, a computer, PDA, portable telephone, or the like. In preferred embodiments, the BG meter **10** may be programmed to reactivate its communication system after a certain duration. In particular embodiments, when the user deactivates the BG meter's communication system, the user is prompted to enter a duration for how long communication system is to be deactivated, and the communication system will automatically become active at the end of the duration. In alternative embodiments, the user may specify a time of day for the communication system to become active. In particular embodiments, all of the BG measurements that have been generated while the communication system was deactivated are transmitted to the infusion pump **50** when the communication system is reactivated. Other data may also be transmitted to the infusion pump **50**, such as the BG meter's clock time when the BG measurement was generated (i.e., the timestamp for the BG measurement), the age of the BG measurement, and the like.

[0063] One-way communication is preferably used between the BG meter **10** and the infusion pump **50**. The BG meter **10** includes a transmitter **15**, and the infusion pump **50** includes a receiver **80**. For example, the BG meter **10** transmits data (e.g., BG measurements or remote control commands), and the infusion pump **50** receives this data. The benefits of one-way communication (compared to two-way) include cheaper unit costs, less development time, and

decreased battery power requirements. However, the drawback of one-way communication is that there is no confirmation that the BG meter **10** has transmitted the data to the infusion pump **50**. Accordingly, in alternative embodiments, two-way communication may be used, and the BG meter **10** may include a transceiver **19** (as shown in FIG. 4(b)) or **36** (as shown in FIG. 5), and the infusion pump **50** may include a transceiver **81** (as shown in FIG. 3(b)).

[0064] In preferred embodiments, the infusion pump **50** uses power cycling to periodically supply power to its communication system. In alternative embodiments, the infusion pump **50** may not use power cycling, and instead, may continuously supply power to its communication system. The power cycle, which is one period that the communication system is off plus one period that the communication system is on, is preferably 8 seconds. In alternative embodiments, the power cycle may be shorter or longer than 8 seconds, such as 2 or 4 seconds, 12 or 15 seconds, or the like. Further, the period that the communication system is on during each power cycle is preferably 48 milliseconds (ms). In alternative embodiments, the period that the communication system is on during each power cycle may be greater or less than 48 ms, depending on the length of the message to be received, the communication frequency, the speed of the communication system electronics, and the like. In preferred embodiments, the BG meter **10** sends repeated signals to the infusion pump **50** for a period longer than the power cycle. The signal sent from the BG meter **10** to the infusion pump **50** preferably includes a command that is short enough to be captured during the on-time of the infusion pump's communication system. In particular embodiments, the command is short enough to be captured multiple times (i.e., two, three, or more times) during the on-time of the infusion pump's communication system.

[0065] In preferred embodiments, the time that the infusion pump's communication system must be on to capture the command from the BG meter **10** is short compared to the power cycle. In further embodiments, the command is short compared to a string of information. When the infusion pump **50** receives a command, the infusion pump **50** stops power cycling the communication system and turns the communication system on continuously. Alternatively, when the infusion pump **50** receives a command, the infusion pump **50** may continue to use power cycling unless the command indicates that the pump **50** should prepare to receive a string of information. Thus, short commands may be used to activate the infusion pump's communication system so that one or more longer strings of information may be received by the infusion pump **50**.

[0066] In particular embodiments, the infusion pump **50** prepares to receive a string of information longer than a command. The string of information preferably includes a BG measurement. The string of information may further include an elapsed time since the BG measurement was taken. In alternative embodiments, the string of information may include a clock time. In further alternative embodiments, the BG meter **10** may transmit a clock time to the infusion pump **50** so that the infusion pump **50** can determine the difference between the BG meter's clock and the infusion pump's clock. In other alternative embodiments, the infusion pump **50** may use the BG meter's clock time to reset the infusion pump's clock time.

[0067] In preferred embodiments, the infusion pump **50** returns to power cycling the communication system after

information has been received from the BG meter **10**. In particular embodiments, the infusion pump **50** returns to power cycling after it receives a complete signal containing a BG measurement from the BG meter **10**. In alternative embodiments, the infusion pump **50** returns to power cycling at a predetermined period after a signal from the BG meter **10** has stopped. In other alternative embodiments, the infusion pump **50** returns to power cycling at a predetermined period after receiving a signal from the BG meter **10**.

[0068] As described above, the infusion pump **50** preferably communicates with various external devices, such as the BG meter **10**, using the RF communication system **60**. In particular embodiments, the RF communication system **60** includes an RF receiver **80**, an RF microcontroller **82** (RF PIC), and an application specific integrated circuit **84** (ASIC), as shown in FIG. 3(a). In other particular embodiments, the RF receiver **80** may be replaced with an RF transceiver **81**, as shown in FIG. 3(b). The RE PIC **82** may hold a 7-byte word, although in alternative embodiments, the RF PIC **82** may hold other lengths of data. The processor **64** communicates with the RF PIC **82** and the ASIC **84** using synchronous peripheral interfaces (SPI interfaces).

[0069] The RF receiver **80** receives and demodulates RF signals, extracts a data packet from the RF signal, and passes the data packet to the RF PIC **82**. The RF PIC **82** accepts and decodes the data packet and checks for format. If the format of the data packet is valid, the RF PIC **82** sends an interrupt signal to the ASIC **84**. When the ASIC **84** receives an interrupt signal from the RF PIC **82**, the ASIC **84** sends an interrupt to the processor **64**, triggering the processor **64** to notify the RF PIC **82** to pass the contents of its buffer to the processor **64**. The processor **64** acquires the decoded data packet from the RF PIC **82** and evaluates the content, which may include a command or information to be stored. In response to some data packets, the processor **64** will send a command to the ASIC **84** to change the power conditions on the RF receiver **80**. The processor **64** also processes the commands and information received from the BG meter **10**, which may result in changing the bolus delivery on the infusion pump **50** or entering a BG measurement into the bolus estimator **62**. One of the main tasks for the ASIC **84** is to enable and disable power on the RF receiver **80**. Generally, the ASIC **84** cycles the power on the RF receiver **80** to save energy. If commanded by the processor **64**, however, the ASIC **84** will enable the RF receiver **80** to be powered continuously.

[0070] Each RF transmission sent to the pump preferably includes an RF signal header followed by a command packet or an information packet. Since the pump's RF receiver **80** is likely to wake up in the middle of a command packet, the RF signal header at the start of each transmission helps the pump **50** to synchronize its data sampling and identify the first byte of a new command packet or information packet. The RF signal header is preferably the same for each transmission, and is transmitted at the start of each RF transmission. The RF signal header may include two parts: a preamble and a start signature. The preamble is a series of pulses used to train the pump's digital signal sampling, and allows the pump **50** to synchronize its pulse sampling with the pulse bits in the new transmission. The start signature notifies the pump RF PIC **82** when the first byte of a new packet is starting. In alternative embodiments, the RF signal header may include other data. In further alternative embodiments, the RF signal header may be omitted.

[0071] In particular embodiments, command packets are 7 bytes in length, and information packets are 71 bytes in length. In alternative embodiments, the command packets and/or information packets may be of different lengths. The last byte of every command or information packet is an 8-bit cyclic redundancy check (CRC) calculated on all the preceding bytes in the packet. Before a command or information packet is sent by the BG meter 10 to the infusion pump 50, it is encoded using a DC balanced encoding scheme, which translates 4 bits of data into 6 for transmission as follows:

HEX	DC
0	010101
1	110001
2	110010
3	100011
4	110100
5	100101
6	100110
7	010110
8	011010
9	011001
A	101010
B	001011
C	101100
D	001101
E	001110
F	011100

[0072] The result of the encoding is that the 7-byte command packets require transmission of 11 bytes and the 71-byte data packets require transmission of 107 bytes. Upon receipt of the 11-byte or 107-byte packets from the BG meter 10, the pump RF PIC 82 in the infusion pump 50 decodes the packet into the 7-byte command packet or the 71-byte information packet. The processor 64 then checks all packets for valid identification of the infusion pump 50 (e.g., identification or serial number) and CRC. If the identification of the infusion pump 50 is not valid, the packet is ignored. If the CRC of the first command packet is not valid, the command is ignored. Otherwise, the processor 64 sends a negative acknowledge (NAK) response to any packet with an invalid CRC.

[0073] Information packets (71 bytes) are much larger than command packets (7 bytes), and cannot be stored in the pump RF PIC 82, and thus, cannot be used to “wake up” the pump 50. Instead, a command packet must be sent to the pump 50 to turn on the pump’s RF receiver 80 and prepare the pump 50 to receive an information packet. While power to the infusion pump’s communication system (i.e. RF receiver 80) is being cycled, a command packet is repeatedly transmitted from the BG meter 10 to the infusion pump 50. If an RF signal (i.e. including the first command packet) is present when the pump’s RF receiver 80 comes on, the pump 50 will attempt to store the contents of the signal in the pump RF PIC 82. The processor 64 will verify whether the content of the signal is a valid command packet. If the command packet is valid, then the pump 50 will stop power cycling and power the RF receiver 80 continuously. Only the first command packet must be transmitted repeatedly. After the RF receiver 80 is on full-time, other command packets can be sent to the pump 50 in quick succession (for example, as quickly as the user can press buttons on the BG meter 10 or other external device to

send the new command packets). Additional command packets or an information packet may also be transmitted to the pump 50.

[0074] The pump 50 preferably recognizes two categories of command packets: remote control or bolus commands and BG measurement commands. Remote control or bolus commands directly control the pump’s insulin bolus delivery. BG measurement commands may transmit a new BG measurement(s) from the BG meter 10 to the pump 50, or alternatively, prepare the pump 50 to receive an information packet containing a new BG measurement value as well as other related data (e.g., a clock time or timestamp of the BG measurement, the age of the BG measurement, or the like) from the BG meter 10.

[0075] The pump 50 may receive a bolus command from the BG meter 10 or a remote programmer associated with the pump 50. The bolus command preferably includes a type code indicating the type of device transmitting the message (e.g., the BG meter 10 or the remote programmer), unique identifying information about the pump 50 (e.g., serial number, identification number, password, or the like), a key code indicating which bolus command button has been pressed (e.g., button “S” 22, button “B” 24, or button “ACT” 26 on the BG meter 10), and a counter indicating the number of times that the button has been pressed. In alternative embodiments, the bolus command may include other information and/or omit some of this data. When the pump 50 receives the bolus command, the processor 64 filters the command to discern the counter value so that the pump 50 can respond to the number of times the user has pressed the button to adjust a bolus.

[0076] The pump 50 may also receive a BG measurement command from the BG meter 10. The BG measurement command is transmitted to the pump 50 to send a new BG measurement(s) from the BG meter 10 to the pump 50, or alternatively, to prepare the pump 50 to receive an information packet containing a new BG measurement as well as other related data (e.g., a clock time or timestamp of the BG measurement, the age of the BG measurement, or the like) from the BG meter 10. If the BG measurement command transmits a new BG measurement(s) from the BG meter 10 to the infusion pump 50, the command preferably includes a type code indicating the type of device transmitting the message (e.g., the BG meter 10), the BG measurement value(s), and unique identifying information about the meter 10 and/or pump 50 (e.g., serial number, identification number, password, or the like). If the BG measurement command is transmitted to prepare the pump 50 to receive an information packet containing a BG measurement and other related data from the BG meter 10, the command preferably includes a type code indicating the type of device transmitting the message (e.g., the BG meter 10), unique identifying information about the meter 10 and/or pump 50 (e.g., serial number, identification number, password, or the like), and a key code indicating that a new BG measurement is about to be transmitted. In alternative embodiments, the BG measurement command may include other information and/or omit some of this data.

[0077] In response to communications from the BG meter 10, the pump 50 typically sends an acknowledge (ACK) response. However, in particular embodiments, the BG meter 10 does not include an RF receiver, and the pump 50 does not include an RF transmitter, and thus, the pump 50 does not send an ACK response if the type code in the command (e.g., bolus or BG measurement command) indicates that the

device transmitting the message is the BG meter 10. In alternative embodiments, both the BG meter 10 and the pump 50 may include an RF transmitter and receiver (i.e. transceiver 19 (shown in FIG. 4(b)) or 36 (shown in FIG. 5) in the BG meter 10' or 10'', and transceiver 81 (shown in FIG. 3(b)) in the infusion pump 50), and thus, the pump 50 may send an ACK response to the BG meter 10. Additionally, the pump 50 may send its clock time to the BG meter 10, and the BG meter 10 may use the pump's clock time to reset the BG meter's clock time if the devices' clock times do not correspond with one another. Further, if the meter 10 does not receive an ACK response from the pump 50, the meter 10 may attempt to retransmit the communication to the pump 50, either immediately or at a later time.

[0078] When the pump 50 receives a command packet from the BG meter 10, the processor 64 will send a data packet through the ASIC 84, commanding the RF receiver 80 to remain on full-time for a specified number of minutes, to receive other command packets or an information packet. The RF receiver 80 may return to power cycling after the information packet has been received, a certain period of time after receiving a BG measurement command (in the event that the anticipated information packet does not arrive), a certain period of time after receiving a bolus command, or after the battery in the pump 50 has been removed and replaced.

[0079] The pump RF PIC 82 remains in receive mode unless it has received a command to send from the processor 64, in which case it shall switch to transmit mode until the transmission is complete. Once the data has been transmitted, the pump RF PIC 82 automatically switches back to receive mode.

[0080] While the description above refers to particular embodiments of the present invention, it will be understood that many modifications may be made without departing from the spirit thereof. The accompanying claims are intended to cover such modifications as would fall within the true scope and spirit of the present invention.

[0081] The presently disclosed embodiments are therefore to be considered in all respects as illustrative and not restrictive, the scope of the invention being indicated by the appended claims, rather than the foregoing description, and all changes which come within the meaning and range of equivalency of the claims are therefore intended to be embraced therein.

1-94. (canceled)

95. An infusion system for infusing insulin into a body of a user, the infusion system comprising:

- a blood glucose test strip meter including:
- a meter housing adapted to be carried by the user;
- a test strip port coupled to the meter housing to receive a test strip and test a blood sample from the user to determine a blood glucose level of the user;
- a meter processor contained in the meter housing and coupled to the test strip port to process the determined blood glucose level from the test strip port; and
- a wireless meter communication transceiver contained in the meter housing and coupled to the meter processor to transmit a communication including data indicative of the determined blood glucose level of the user and to receive a confirmation of receipt of the data; and
- an infusion device including:
- an infusion device housing adapted to be carried by the user;

- a drive mechanism contained in the infusion device housing and operatively coupled with a reservoir containing insulin to infuse insulin into the body of the user;

- a wireless infusion device communication transceiver contained in the infusion device housing to receive from the wireless meter communication transceiver the communication including the data indicative of the determined blood glucose level of the user and to transmit the confirmation of receipt of the data to the wireless meter communication transceiver; and

- an infusion device processor contained in the infusion device housing and coupled to the wireless infusion device communication system to process the data indicative of the determined blood glucose level of the user and to control the infusion device.

96. The infusion system according to claim 95, wherein the wireless meter communication system automatically transmits the communication including the data indicative of the determined blood glucose level of the user to the wireless infusion device communication system.

97. The infusion system according to claim 95, further including:

- a bolus estimator used in conjunction with the infusion device processor to calculate an estimated amount of insulin to be infused into the body of the user based upon the received data indicative of the determined blood glucose level of the user and a target concentration of blood glucose in the user; and

- an infusion device indicator to indicate when the estimated amount of insulin to be infused has been calculated

98. The infusion system according to claim 95, wherein the blood glucose test strip meter further includes an indicator to indicate a status of the communication including the data indicative of the determined blood glucose level of the user being transmitted from the wireless meter communication transceiver to the wireless infusion device communication transceiver, or to indicate the confirmation of receipt of the data transmitted from the wireless infusion device communication transceiver to the wireless meter communication transceiver.

99. The infusion system according to claim 95, wherein the communication transmitted from the wireless meter communication transceiver to the wireless infusion device communication transceiver further includes a time at which the blood glucose level of the user was determined.

100. The infusion system according to claim 95, wherein the blood glucose test strip meter has a unique identification information, and the communication transmitted from the wireless meter communication transceiver to the wireless infusion device communication transceiver further includes the unique identification information of the blood glucose test strip meter such that the infusion device is capable of discerning whether the communication is intended for receipt by the infusion device.

101. The infusion system according to claim 95, wherein the wireless meter communication transceiver and the wireless infusion device communication transceiver communicate using one of radio frequencies and infrared frequencies.

102. The infusion system according to claim 95, wherein the infusion device is an insulin infusion pump.

103. The infusion system according to claim 97, wherein the infusion device further includes a user input device for inputting an estimate of a material to be ingested by the user, and further wherein the bolus estimator includes the capabil-

ity to calculate the estimated amount of insulin to be infused into the body of the user based upon the inputted estimate of the material to be ingested by the user.

104. The infusion system according to claim **95**, wherein the infusion device further includes a memory for storing data, and further wherein the data indicative of the determined blood glucose level of the user received by the wireless infusion device communication transceiver from the wireless meter communication transceiver is stored in the memory of the infusion device.

105. In an infusion system including a blood glucose test strip meter and an infusion device, a method for infusing insulin into a body of a user, the method comprising the steps of:

- receiving and testing a blood sample from the user on a test strip to determine a blood glucose level of the user;
- transmitting wirelessly with the blood glucose test strip meter to the infusion device a communication including data indicative of the blood glucose level of the user;
- receiving wirelessly with the infusion device the communication including the data indicative of the blood glucose level of the user;
- transmitting wirelessly with the infusion device to the blood glucose test strip meter a confirmation of receipt of the data; and
- receiving wirelessly with the blood glucose test strip meter the confirmation of receipt of the data.

106. The method according to claim **105**, further comprising:

- calculating an estimated amount of insulin to be infused into the body of the user based upon the received data indicative of the blood glucose level of the user and a target concentration of blood glucose in the user; and
- indicating when the estimated amount of insulin to be infused has been calculated.

107. The method according to claim **105**, wherein the blood glucose test strip meter automatically transmits the

communication including the data indicative of the determined blood glucose level of the user.

108. The method according to claim **105**, further comprising indicating a status of the communication including the data indicative of the determined blood glucose level of the user being transmitted wirelessly from the blood glucose test strip meter to the infusion device.

109. The method according to claim **105**, wherein the communication including the data indicative of the determined blood glucose level of the user transmitted wirelessly from the blood glucose test strip meter to the infusion device further includes a time at which the blood glucose level of the user was determined.

110. The method according to claim **105**, wherein the communication transmitted wirelessly from the blood glucose test strip meter to the infusion device includes a unique identification information of the blood glucose test strip meter such that the infusion device is capable of discerning whether the communication is intended for receipt by the infusion device.

111. The method according to claim **105**, wherein the blood glucose test strip meter and the infusion device communicate wirelessly using one of radio frequencies and infrared frequencies.

112. The method according to claim **105**, wherein the blood glucose test strip meter includes a transceiver, and the infusion device includes a transceiver.

113. The method according to claim **106**, further comprising inputting an estimate of a material to be ingested by the user, wherein the estimated amount of insulin to be infused into the body of the user is calculated further based upon the inputted estimate of the material to be ingested by the user.

114. The method according to claim **105**, further comprising storing in a memory of the infusion device the data indicative of the determined blood glucose level of the user received by the infusion device from the blood glucose test strip meter.

* * * * *