

Aug. 9, 1927.

1,638,280

C. W. UTZMAN

FABRICATED BOARD

Original Filed April 19, 1920

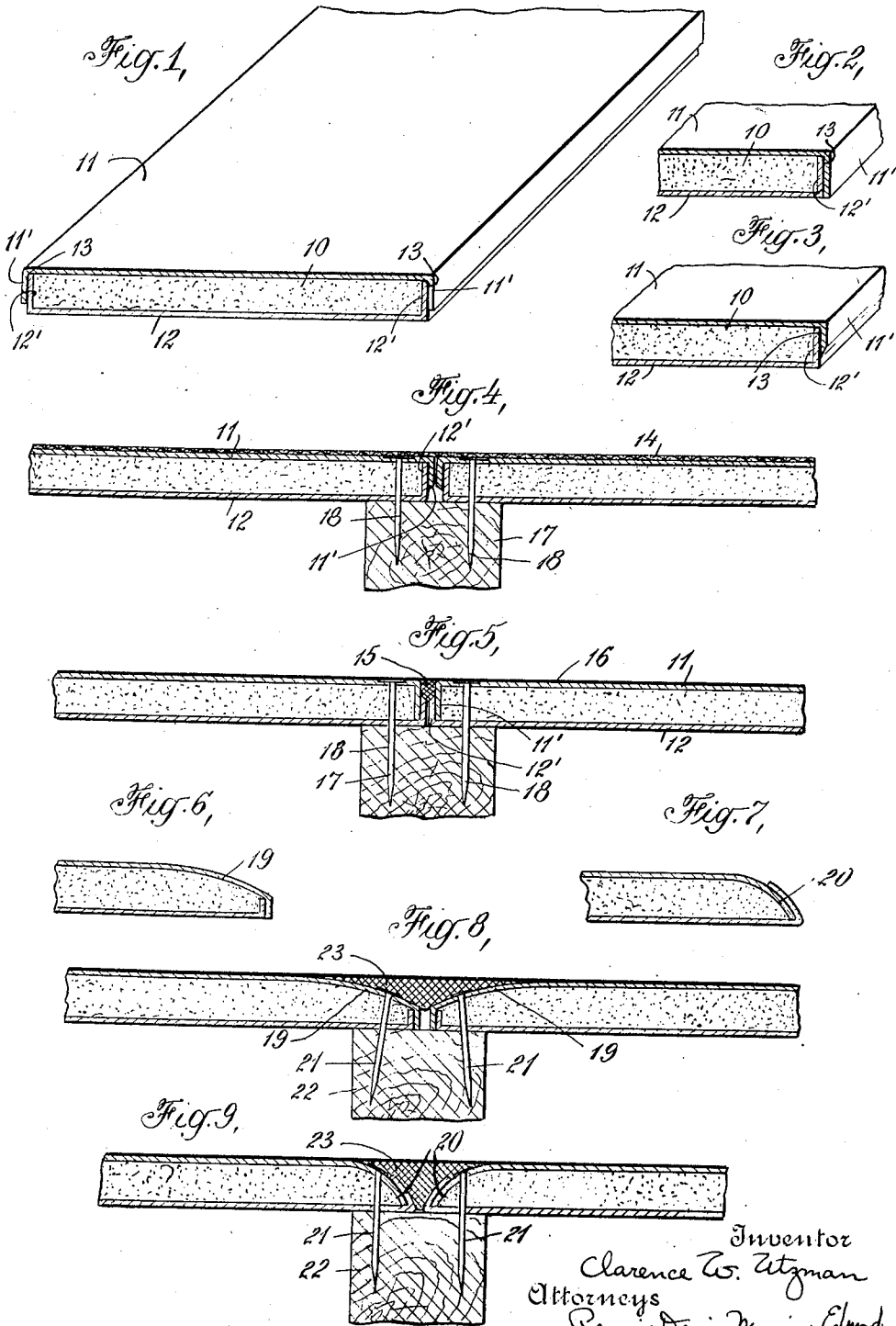

Inventor
Clarence W. Utzman
Attorneys
Senn, Davis, Martin & Edmond

UNITED STATES PATENT OFFICE.

CLARENCE W. UTZMAN, OF BUFFALO, NEW YORK, ASSIGNOR, BY MESNE ASSIGNMENTS, TO UNITED STATES GYPSUM COMPANY.

FABRICATED BOARD.

Application filed April 19, 1920, Serial No. 374,833. Renewed January 5, 1923.

This invention relates to fabricated board, such, for example, as the so-called plaster board of commerce, and has for its object the provision of an improved fabricated board having a body portion containing a cementitious hardened mixture. More particularly, the invention aims to provide an improved form or arrangement of covering sheet for protecting the surfaces and edges of the cementitious mixture body portion of a fabricated board.

The so-called plaster board of commerce consists generally of a sheet or slab of cementitious mixture, such as plaster, having its surfaces covered with enclosing sheets of paper, fabric, or other appropriate material. The body portion of the board is made up for the most part of stucco or calcined gypsum which gives rigidity and strength to the sheet or slab when hardened or set. The function of the covering sheet or sheets is generally to protect the hardened body portion of the board, to give tensile strength and to prevent breakage and chipping during the usual handling to which the board is subjected in the course of manufacture, transportation and assembling.

The present invention contemplates the provision of a fabricated board having a body portion containing a cementitious mixture with covering sheets of such a character and so arranged as to provide a maximum of protection against breakage and chipping of the surfaces and edges of the body portion. Moreover, the invention contemplates the provision of a double-faced board, that is, a board in which the two flat surfaces or faces are substantially of the same character so that either may be exposed when erecting the board. The invention further contemplates the provision of a fabricated board of the character hereinbefore described which can be conveniently nailed or otherwise secured to the studding of a building without danger of chipping or fracturing the hardened body portion, and which is moreover of such configuration that the attaching means can be easily covered over and obscured after the boards have been erected. These and other objects of the invention will be brought out in the follow-

ing description. The present invention contemplates the further desirable and novel features over that of previous constructions, namely, that of deriving the full tensile and shearing strength of the covering sheet for the entire width thereof, irrespective of which side may be erected to the supports and without respect to the amount of bearing that the sheet may have upon its support.

The plaster board of the present invention comprises a body portion of hardened plaster having a covering sheet adhering to and completely covering each of the flat surfaces or faces thereof. The two covering sheets are of substantially the same width and each is of greater width than the width of the body portion. The sides or longitudinal ends of each of the covering sheets are turned or folded over the longitudinal edges of the flat surface or face of the body portion to which the particular covering sheet adheres, and the turned-over sides of the covering sheets appropriately overlap on the longitudinal edge surfaces of the body portion. Preferably, the folded over sides of one of the covering sheets completely cover the longitudinal edge surface of the body portion, and the overlapping folded-over sides of the other covering sheet may completely or only partially cover the folded over sides of the other covering sheet. The folded over sides of the covering sheets are cemented together by adhesive other than that comprising the body portion of the board. Preferably, this adhesive is resistant to both water and extreme temperatures.

The novel features of the invention which I believe to be patentable are definitely pointed out in the appended claims. These features, together with the construction of a fabricated board embodying the same, will be understood from the following description taken in conjunction with the accompanying drawings, in which:

Fig. 1 is a perspective view of a fabricated board embodying certain improvements of the invention;

Figs. 2 and 3 illustrate modified arrangements of the covering sheets;

Figs. 4 and 5 are explanatory views il-

illustrating different modes of assembling fabricated boards embodying the invention;

Figs. 6 and 7 are detail sectional views particularly illustrating certain features of the invention; and

Figs. 8 and 9 are explanatory views illustrating the mode of assembling the fabricated boards shown in Figs. 6 and 7, respectively.

The fabricated board of the invention, as illustrated in the accompanying drawings, comprises a body portion 10 containing hardened plaster. Usually, this body portion is made up of stucco or calcined gypsum. The stucco or calcined gypsum is first made into a plastic mass by the addition of water, and usually 10 to 15% of fibrous material, such as sawdust or wood pulp, is added to the mixture. The plastic mass is then formed into a sheet or slab of the desired dimensions and enclosed in the covering sheets. Usually, these operations of shaping the body portion of the board and enclosing it in the covering sheets are performed in a continuous manner in a machine particularly adapted and designed for this purpose. In the accompanying drawings, the covering sheets are represented by reference numerals 11 and 12.

In accordance with the present invention, the covering sheets 11 and 12 are each of greater width than the width of the flat surfaces or faces of the body portion of the board. These covering sheets, therefore, completely cover the flat surfaces of the body portion and have their sides turned over and terminate along the longitudinal edge surfaces of the body portion. Thus, it will be observed by reference to Fig. 1 of the accompanying drawings that the sides 12' of the lower covering sheet 12 are turned over the longitudinal edges of the lower face of the body portion 10 and that these turned-over sides 12' cover substantially the entire longitudinal edge surfaces of the body portion. Similarly, the sides 11' of the upper covering sheet 11 are turned over the longitudinal edges of the upper face of the body portion, and these turned-over sides 11' appropriately overlap the turned-over sides 12'. The turned-over sides 11' of the one covering sheet may completely overlap the turned over sides 12' of the other covering sheet, as illustrated in Fig. 2 of the accompanying drawings, or these turned-over sides may overlap so as to expose on the longitudinal edge surface of the board a portion of each turned-over side, as illustrated in Figs. 1 and 3 of the accompanying drawings.

The overlapping sides 11' and 12' of the covering sheets are cemented together by an appropriate adhesive, which is indicated in the accompanying drawings by reference nu-

meral 13. This adhesive is of different composition than the body portion of the board, and preferably is a water resistant and heat-resistant material. Thus, for example, silicate of soda, insoluble glues, pitch, tar, or the like, may be employed as the adhesive for cementing together the overlapping sides of the covering sheets.

The edge of the turned-over sides 11' of the covering sheet 11 may, if desired, be bevelled, as indicated in Fig. 3 of the accompanying drawings. The folded over edge of the covering sheet may thus be either trimmed flush with the full thickness of the board, as shown in Fig. 2, or may be cut back as shown in Fig. 1, or may be bevelled as shown in Fig. 3, thereby providing various conditions at the edge of the board which give a wide range of decorative treatment according to the manner of application of the board to the wall with either side to the supports, or according to the character of the final decorative surface desired. In Fig. 4 of the accompanying drawings, a manner of assembling the boards is shown so as to provide a substantially flush and continuous exposed surface which is particularly adapted to be covered with a fabric decoration 14. In Fig. 5 of the accompanying drawings, the boards are represented as assembled in such a manner as to provide a space or depression 15 between adjacent boards. This depression is filled with an appropriate binder which is preferably of a composition similar to the composition of the body portion of the board. By filling in these depressions 15, a smooth continuous exposed surface is obtained when the boards are assembled side by side. This surface may be covered with a fabric decoration or with a liquid coating decoration 16. In Figs. 4 and 5, the boards are secured to the studding or frame 17 by nails 18.

In Figs. 6 and 7 of the accompanying drawings, I have illustrated a fabricated board in which one or more of the edges of one face of the body portion are given such a contour as to provide a space or depression between adjacent boards when assembled side by side. One face, that is the inner face, when assembled, of the body portion of the board is flat throughout, while the opposite face has one or more edges thereof curved. In Fig. 6 of the drawings, the curved contour 19 extends down over only a portion of the longitudinal edge surface of the board, and the remainder of this longitudinal edge surface is square with the inner flat face of the board. On the other hand, in the modification illustrated in Fig. 7, the entire longitudinal edge of the board is given a rounded contour as indicated by reference numeral 20. The sides of the covering sheets termi-

nate on the longitudinal edges of the board and overlap as in the arrangements previously described.

Figs. 8 and 9 of the accompanying drawings illustrate the manner of assembling fabricated boards of the form illustrated in Figs. 6 and 7, respectively. The fastening means, such as nails 21, are driven through the board at the rounded edge thereof. Inasmuch as the inner face or surface of the board is substantially flat and flush with the support 22, there is little or no danger of cracking or chipping the board when the nail 21 is thus driven through. The depressions or spaces 23 between adjacent boards are filled with an appropriate binder in substantially the same manner as described in connection with Fig. 5. The outer or exposed surface of the assembled boards may be decorated in any appropriate manner, as, for example, by decorative fabric or by paint or other appropriate liquid coating composition.

Each covering sheet, in accordance with the present invention, extends over the entire face of the plaster body portion to which it adheres and is securely fastened on both sides to the longitudinal edge surfaces of the body portion. By this arrangement, there results a remarkably strong board having a doubly reinforced edge, and possessing a high degree of strength on each face when subjected to either tension or compression strains. Moreover, by positively securing each side of the covering sheet to an edge surface of the body portion a full grip is provided for the covering sheet thereby increasing the bending resistance, as well as providing improved shearing strength over the entire area of both faces of the board.

A further advantage of the arrangement of the invention resides in the feature of the edges of the boards, when assembled side by side, forming either a closed joint sufficiently accurate for all practical purposes when used for paper or similar decoration, and at the same time of forming, when the boards are assembled side by side with the reversed faces exposed, predetermined and uniformly defined spaces or depressions which can be easily and quickly filled with a binder. The binder effectively connects the adjacent boards and renders the joints invisible when the exposed surface of the assembled boards is covered with paint or similar decorative agent.

In manufacturing, the improved arrangement of the covering sheets is of particular advantage in that only one width of covering sheet need be provided for both sides of the body portion, and in assembling, the improved board is of special advantage in that both faces or sides are alike, thereby permitting either side to be exposed and

decorated if desired, so that the utility of the board is not impaired if one face is damaged in transportation or handling.

I claim:

1. A fabricated board comprising a body portion containing a hardened cementitious mixture, a covering sheet adhering to each of the flat surfaces of said body portion and of greater width than said surfaces, each side of each of said covering sheets terminating on the adjacent longitudinal edge surface of said body portion where the adjacent ends of the covering sheets appropriately overlap so that each covering sheet is folded over and protects the two longitudinal edges of the surface of the body portion to which it adheres, and an adhesive of different composition than said body portion for cementing together the overlapping longitudinal ends of said covering sheets.

2. A fabricated board comprising a body portion containing hardened plaster, a covering sheet adhering to each of the flat surfaces of said body portion and of greater width than said surfaces, one of said covering sheets having each of its sides folded over a longitudinal edge of the surface to which it adheres so as to substantially cover the adjacent longitudinal edge surface of the body portion, the other of said covering sheets also having each of its sides folded over a longitudinal edge of the surface to which it adheres so as to overlap but not completely cover the folded over sides of the other covering sheet, and a water-proof adhesive cementing together the overlapping sides of said covering sheets.

3. A fabricated board comprising a body portion containing a hardened cementitious mixture, one face of said body portion being substantially flat throughout and the other face of said body portion having one or more of its longitudinal edges of rounded contour so as to provide a depression adjacent to the edges of the boards when assembled side by side, a covering sheet adhering to each of the flat surfaces of said body portion and terminating on the longitudinal edge surfaces of the body portion where the covering sheets appropriately overlap, and means for cementing together the overlapping portions of the covering sheets.

4. A fabricated board comprising a body portion containing a hardened cementitious mixture, one face of said body portion being substantially flat throughout and the other face of said body portion having its longitudinal edges of rounded contour, said rounded contour including only a part of the longitudinal edge surfaces of the body portion, a covering sheet adhering to each of the flat surfaces of said body portion and terminating on the portion of the longitudinal edge surfaces of the body portion which are not of rounded contour where the

covering sheets appropriately overlap, and means for cementing together the overlapping portions of the covering sheets.

- 5 5. A fabricated board comprising a body portion containing a hardened cementitious mixture, and a covering sheet adhering to and completely covering each of the flat surfaces of said body portion and terminating on the longitudinal edge surfaces of the body portion where the ends of the covering sheets overlap, and an adhesive of different composition for said body portion for cementing together the overlapping portions of the covering sheets.
- 10 6. A plaster board construction comprising, in combination, separate plaster boards, one of the faces of which is flat and the other face of each having adjacent depressed margins, whereby when the boards are erected edge to edge with right faces adjacent, one surface will be plane and the other surface will have a depression; and fibrous covering material covering said depressed surface and arranged to be interposed between the depressed surface and the filling material for filling the depression to provide a flush surface, said fibrous material being capable of mutually reinforcing the filling material and the depressed surface.
- 15 20 25

In testimony whereof I affix my signature.

CLARENCE W. UTZMAN.