

(19) World Intellectual Property Organization
International Bureau



(43) International Publication Date
19 February 2009 (19.02.2009)

PCT

(10) International Publication Number
WO 2009/022878 A2

- (51) International Patent Classification:
H04B 7/26 (2006.01)
- (21) International Application Number:
PCT/KR2008/004753
- (22) International Filing Date: 14 August 2008 (14.08.2008)
- (25) Filing Language: English
- (26) Publication Language: English
- (30) Priority Data:
60/956,117 15 August 2007 (15.08.2007) US
- (71) Applicant (for all designated States except US): **LG ELECTRONICS INC.** [KR/KR]; 20, Yeouido-dong, Yeongdeungpo-gu, Seoul 150-721 (KR).
- (72) Inventors; and
- (75) Inventors/Applicants (for US only): **FISCHER, Patrick** [DE/FR]; 7 Bis, Rue An dre Theuriet,, 92340, Bourg La Reine (FR). **FEUILLETTE, Remi** [FR/FR]; 7 rue Girardon, 75018, Paris (FR). **VUJCIC, Dragan** [FR/FR]; 8ter, Rue des Cendrieres, Rue des Cendrieres, 91470 Limours (FR).
- (74) Agents: **KIM, Yong In** et al.; KBK & Associates, 7th Floor, Hyundai Building, 175-9 Jamsil-dong, Songpa-ku, Seoul 138-861 (KR).
- (81) Designated States (unless otherwise indicated, for every kind of national protection available): AE, AG, AL, AM, AO, AT, AU, AZ, BA, BB, BG, BH, BR, BW, BY, BZ, CA, CH, CN, CO, CR, CU, CZ, DE, DK, DM, DO, DZ, EC, EE, EG, ES, FI, GB, GD, GE, GH, GM, GT, HN, HR, HU, ID, IL, IN, IS, JP, KE, KG, KM, KN, KP, KR, KZ, LA, LC, LK, LR, LS, LT, LU, LY, MA, MD, ME, MG, MK, MN, MW, MX, MY, MZ, NA, NG, NI, NO, NZ, OM, PG, PH, PL, PT, RO, RS, RU, SC, SD, SE, SG, SK, SL, SM, ST, SV, SY, TJ, TM, TN, TR, TT, TZ, UA, UG, US, UZ, VC, VN, ZA, ZM, ZW.
- (84) Designated States (unless otherwise indicated, for every kind of regional protection available): ARIPO (BW, GH, GM, KE, LS, MW, MZ, NA, SD, SL, SZ, TZ, UG, ZM, ZW), Eurasian (AM, AZ, BY, KG, KZ, MD, RU, TJ, TM), European (AT, BE, BG, CH, CY, CZ, DE, DK, EE, ES, FI, FR, GB, GR, HR, HU, IE, IS, IT, LT, LU, LV, MC, MT, NL,

[Continued on next page]

(54) Title: SIGNALING FOR PREAMBLE USED FOR RANDOM ACCESS

FIG. 4A

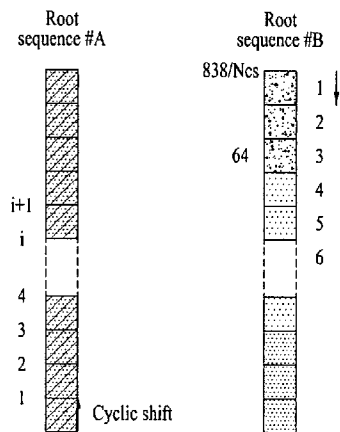

Option 1

- Signature for the contention based Random access
- Signatures from set 1
- Unused space of the root index. Signature available for reservation
- Signatures from set 2
- Signature for the contention based Random access for which reservation is allowed

(57) Abstract: Methods for allocating and choosing dedicated signatures for random access are provided. Options for allocating dedicated signatures include allocating the dedicated signature from the unused space of the random signature root index when there is unused space and allocating more dedicated signatures from the same root index using the same time/frequency resources if additional signatures are needed, and reserving some preambles from the contention-based random access preambles from both sets of preambles. The present invention also proposes that the dedicated signatures be reserved in each of two sets of preambles.

WO 2009/022878 A2



NO, PL, PT, RO, SE, SI, SK, TR), OAPI (BF, BJ, CF, CG,
CI, CM, GA, GN, GQ, GW, ML, MR, NE, SN, TD, TG).

Published:

- *without international search report and to be republished
upon receipt of that report*

【DESCRIPTION】**【Invention Title】**

SIGNALING FOR PREAMBLE USED FOR RANDOM ACCESS

【Technical Field】

5 The present invention is directed to different methods for allocating and choosing dedicated signatures for random access.

【Background Art】

Universal mobile telecommunications system (UMTS) is a 3rd
Generation (3G) asynchronous mobile communication system operating
10 in wideband code division multiple access (WCDMA) based on European
systems, global system for mobile communications (GSM) and general
packet radio services (GPRS). The long-term evolution (LTE) of UMTS
is under discussion by the 3rd generation partnership project (3GPP)
that standardized UMTS.

15 The 3GPP LTE is a technology for enabling high-speed packet
communications. Many schemes have been proposed for the LTE objective
including those that aim to reduce user and provider costs, improve
service quality, and expand and improve coverage and system capacity.
The 3GLTE requires reduced cost per bit, increased service availability,
20 flexible use of a frequency band, a simple structure, an open interface,
and adequate power consumption of a terminal as an upper-level
requirement.

FIG. 1 is a block diagram illustrating network structure of an
evolved universal mobile telecommunication system (E-UMTS). The
25 E-UMTS may be also referred to as an LTE system. The communication

network is widely deployed to provide a variety of communication services such as voice and packet data.

As illustrated in FIG. 1, the E-UMTS network includes an evolved UMTS terrestrial radio access network (E-UTRAN) and an Evolved Packet Core (EPC) and one or more user equipment. The E-UTRAN may include one or more evolved NodeB (eNB) 20, and a plurality of user equipment (UE) 10 may be located in one cell. One or more E-UTRAN mobility management entity (MME)/system architecture evolution (SAE) gateways 30 may be positioned at the end of the network and connected to an external network.

As used herein, "downlink" refers to communication from an eNB 20 to a UE 10, and "uplink" refers to communication from the UE to an eNB. The UE 10 is communication equipment carried by a user and may also be referred to as a mobile station (MS), a user terminal (UT), a subscriber station (SS) or a wireless device.

An eNB 20 provides end points of a user plane and a control plane to the UE 10. The MME/SAE gateway 30 provides an end point of a session and mobility management function for a UE 10. The eNB 20 and MME/SAE gateway 30 may be connected via an S1 interface.

The eNB 20 is generally a fixed station that communicates with a UE 10 and may also be referred to as a base station (BS) or an access point. One eNB 20 may be deployed per cell. An interface for transmitting user traffic or control traffic may be used between eNBs 20.

The MME provides various functions including distributing paging

messages to the eNBs 20, security control, idle state mobility control, SAE bearer control, and ciphering and integrity protection of non-access stratum (NAS) signaling. The SAE gateway host provides assorted functions including termination of U-plane packets for paging
5 reasons and switching the U-plane to support UE 10 mobility.

The MME/SAE gateway 30 will be referred to herein simply as a "gateway" for clarity. However, it is understood that the MME/SAE gateway 30 includes both an MME and an SAE gateway.

A plurality of nodes may be connected between the eNB 20 and the
10 gateway 30 via the S1 interface. The eNBs 20 may be connected to each other via an X2 interface and neighboring eNBs may have a meshed network structure that has the X2 interface.

FIG. 2(a) is a block diagram depicting architecture of a typical E-UTRAN and a typical gateway 30. As illustrated in FIG. 2(a), the
15 eNB 20 may perform functions such as selection for gateway 30, routing toward the gateway during a Radio Resource Control (RRC) activation, scheduling and transmitting paging messages, scheduling and transmitting Broadcast Channel (BCCH) information, dynamic allocation of resources to UEs 10 in both uplink and downlink, configuration
20 and provisioning eNB measurements, radio bearer control, radio admission control (RAC), and connection mobility control in LTE_ACTIVE state. In the EPC, the gateway 30 may perform functions such as paging origination, LTE-IDLE state management, ciphering the user plane, System Architecture Evolution (SAE) bearer control, and ciphering
25 and integrity protection of Non-Access Stratum (NAS) signaling.

FIGS. 2(b) and 2(c) are block diagrams depicting the user-plane protocol and the control-plane protocol stack for the E-UMTS. As illustrated in FIGS. 2(b) and 2(c), the protocol layers may be divided into a first layer (L1), a second layer (L2) and a third layer (L3) based upon the three lower layers of an open system interconnection (OSI) standard model that is well-known in the art of communication systems.

The physical layer, or first layer (L1), provides an information transmission service to an upper layer by using a physical channel. The physical layer is connected to a medium access control (MAC) layer located at a higher level through a transport channel, with data transferred between the MAC layer and the physical layer via the transport channel. Data is transferred via a physical channel between different physical layers, such as between the physical layer of a transmission side and the physical layer of a reception side.

The MAC layer of Layer 2 (L2) provides services to a radio link control (RLC) layer, which is a higher layer, via a logical channel. The RLC layer of Layer 2 (L2) supports the transmission of data with reliability. It should be noted that although the RLC layer is illustrated in FIGS. 2(b) and 2(c), the RLC layer is not required if the MAC layer performs the RLC functions.

The PDCP layer of Layer 2 (L2) performs a header compression function that reduces unnecessary control information. This allows efficient transmission of data utilizing Internet protocol (IP) packets, such as IPv4 or IPv6, over a radio or wireless interface that has a relatively

small bandwidth.

A radio resource control (RRC) layer located at the lowest portion of the third layer (L3) is only defined in the control plane and controls logical channels, transport channels and the physical channels in relation to the configuration, reconfiguration, and release of the radio bearers (RBs). A RB signifies a service provided by the second layer (L2) for data transmission between a UE 10 and the E-UTRAN.

As illustrated in FIG. 2(b), the RLC and MAC layers are terminated in an eNB 20 on the network side and may perform functions such as scheduling, Automatic Repeat Request (ARQ), and hybrid automatic repeat request (HARQ). The PDCP layer is terminated in an eNB 20 on the network side and may perform the user plane functions such as header compression, integrity protection, and ciphering.

As illustrated in FIG. 2(c), the RLC and MAC layers are terminated in an eNB 20 on the network side and perform the same functions as for the control plane. As illustrated in FIG. 2(c), the RRC layer is terminated in an eNB 20 on the network side and may perform functions such as broadcasting, paging, RRC connection management, Radio Bearer (RB) control, mobility functions, and UE 10 measurement reporting and controlling. As illustrated in FIG. 2(c), the NAS control protocol is terminated in the MME of gateway 30 on the network side and may perform functions such as a SAE bearer management, authentication, LTE_IDLE mobility handling, paging origination in LTE_IDLE, and security control for signaling between the gateway and UE 10.

The NAS control protocol may use three different states. An

LTE_DETACHED state is used if there is no RRC entity. An LTE_IDLE state is used if there is no RRC connection while storing minimal UE 10 information. An LTE_ACTIVE state is used if the RRC connection is established. Furthermore, the RRC state may be divided into two
5 different states, such as RRC_IDLE and RRC_CONNECTED.

In RRC_IDLE state, the UE 10 may receive broadcasts of system information and paging information while the UE specifies a Discontinuous Reception (DRX) configured by the NAS and the UE has been allocated an identification (ID) which uniquely identifies the
10 UE in a tracking area. Furthermore, no RRC context is stored in the eNB in RRC-IDLE state.

In RRC_CONNECTED state, the UE 10 has an E-UTRAN RRC connection and a context in the E-UTRAN, such that transmitting and / or receiving data to and from the eNB is possible. Furthermore, the UE 10 can report
15 channel quality information and feedback information to the eNB.

In RRC_CONNECTED state, the E-UTRAN knows the cell to which the UE 10 belongs. Therefore, the network can transmit and / or receive data to and from the UE 10, control mobility, such as handover, of the UE, and perform cell measurements for a neighboring cell.

20 In RRC_IDLE mode, the UE 10 specifies the paging DRX Discontinuous Reception cycle. Specifically, the UE 10 monitors a paging signal at a specific paging occasion of every UE specific paging DRX cycle.

FIG. 3 illustrates the conventional LTE handover procedure. The UE 10 sends a measurement report to the source eNB 20 (S102). The
25 source eNB 20 sends a handover request message with the UE 10 context

to the target eNB (S104).

The target eNB 20 sends a handover request response to the source eNB (S106). The handover request response includes the new CRNTI, a portion of a handover command message and information related to random access, such as a dedicated access signature for the UE 10 to make a contention-free random access on the target cell. A signature is reserved at this time.

The source eNB 20 sends the handover command to the UE (S108). The handover command includes the new C-RNTI and information related to random access, such as the dedicated signature for the UE 10 to use.

A random access procedure is performed in the target cell after the handover command in order for the UE 10 to obtain the timing advance (TA) value. This random access procedure should be contention-free such that a signature is reserved to the UE 10 in order to avoid collision.

The UE 10 starts the random access procedure on the target eNB 20 by sending the random access preamble using a dedicated signature (S110). The target eNB 20 sends the random access response message to the UE 10 (S112). The random access response message includes the TA and uplink resource assignment. The UE 10 sends the handover complete message to the target eNB 20 (S114)

The LTE random access procedure may be either contention-based or contention-free. The random access preamble is contention-based when the UE 10 randomly chooses the preamble from among the available set of signatures. The random access preamble is contention-free when

the UE 10 is assigned the signature for use by the eNB 20 via dedicated signaling.

【Disclosure】

【Technical Problem】

5 The dedicated signature assignment can occur for handover and upon the arrival of downlink data if the UE 10 is not time-aligned. The random access preambles for both contention-based and contention-free random access should be based on Zadoff-Chu sequence with Zero Correlation Zone (ZC-ZCZ). The current LTE random access procedure
10 uses two sets of signatures.

【Technical Solution】

In one aspect of the present invention, a method of requesting a random access connection between a wireless mobile terminal and a base station is provided. The method includes receiving information
15 including at least one signature root sequence index, a cyclic shift parameter and a signature set identifier representing a boundary between a first signature set corresponding to a first transport format and a second signature set corresponding to a second transport format and preparing random access signatures according to the at least one
20 signature root sequence index and the cyclic shift parameter, wherein at least one of the random access signatures is associated with the first signature set and the rest of the random access signatures are associated with the second signature set.

It is contemplated that the signature set identifier comprises
25 a plurality of steps, each of the plurality of steps including a

plurality of signatures. It is further contemplated that the signature set identifier comprises one of a plurality of predefined borders between the first signature set and second signature set.

In another aspect of the present invention, a mobile terminal for
5 requesting a random access connection with a base station is provided. The mobile terminal includes a transmitting unit for transmitting information, a receiving unit for receiving information, a display unit for displaying information, an input unit for receiving inputs from a user and a processing unit processing received information
10 including at least one signature root sequence index, a cyclic shift parameter and a signature set identifier representing a boundary between a first signature set corresponding to a first transport format and a second signature set corresponding to a second transport format, and preparing random access signatures according to the at least one
15 signature root sequence index and the cyclic shift parameter, wherein at least one of the random access signatures is associated with the first signature set and the rest of the random access signatures are associated with the second signature set.

It is contemplated that the signature set identifier comprises
20 a plurality of steps, each of the plurality of steps including a plurality of signatures. It is further contemplated that the signature set identifier comprises one of a plurality of predefined borders between the first signature set and second signature set.

Additional features and advantages of the invention will be set
25 forth in the description which follows, and in part will be apparent

from the description, or may be learned by practice of the invention. It is to be understood that both the foregoing general description and the following detailed description of the present invention are exemplary and explanatory and are intended to provide further explanation of the invention as claimed.

These and other embodiments will also become readily apparent to those skilled in the art from the following detailed description of the embodiments having reference to the attached figures, the invention not being limited to any particular embodiments disclosed.

10 **【Advantageous Effects】**

An advantage of the first scheme is that a large number of preambles may be generated that are completely independent from the preambles used for contention-based random access. Advantages of the second scheme are that no additional ZC indexes are necessary and there is no need to use a new root sequence. An advantage of the third scheme is that no additional ZC indexes are required. An inconvenience of the fourth scheme is a decreased number of available preambles for non-contention based RACH, thereby increasing the collision probability.

20 **【Description of Drawings】**

The accompanying drawings, which are included to provide a further understanding of the invention and are incorporated in and constitute a part of this specification, illustrate embodiments of the invention and together with the description serve to explain the principles of the invention. Features, elements, and aspects of the invention

that are referenced by the same numerals in different figures represent the same, equivalent, or similar features, elements, or aspects in accordance with one or more embodiments.

FIG. 1 illustrates the network structure of an E-UMTS.

5 FIG. 2(a) illustrates the architecture of an E-UTRAN and gateway.

FIGS. 2(b) and 2(c) illustrate the user-plane protocol and control-plane protocol for the E-UMTS.

Fig. 3 illustrates the conventional handover procedure for LTE.

10 FIG. 4(a) and 4(b) illustrate a method of dedicated signature allocation according to one embodiment of the present invention.

FIG. 5 illustrates a block diagram of a mobile station according to the present invention.

【Best Mode】

15 Reference will now be made in detail to the preferred embodiments of the present invention, examples of which are illustrated in the accompanying drawings. The present invention presents several schemes for allocating dedicated signatures.

20 In a first scheme, signatures are allocated from separate root sequences. In this scheme, the signatures used for non-contention based random access are generated using different ZC root sequences than those used to generate contention-based random access preambles.

25 An advantage of the first scheme is that a large number of preambles may be generated that are completely independent from the preambles used for contention-based random access. Disadvantages of the first scheme are that the use of a new root sequence in a cell results in

more interferences, more root sequences used per cell and cross-correlation and detection are more complex.

In a second scheme, signatures are allocated from the unused space of the random signature root index. In this scheme, different code
5 resources are used for dedicated and random signatures.

The last sequence index used for contention-based signature opportunity is not necessarily fully allocated to generate the 64 signatures since the cyclic shift value is related to the cell size in that the shift must be larger than the maximum propagation delay
10 for a given cell size. This allows the allocation of the remaining unused signatures to the contention-free access procedure.

Advantages of the second scheme are that no additional ZC indexes are necessary and there is no need to use a new root sequence. A disadvantage of the second scheme is that the number of remaining
15 signatures opportunity is not fixed and may also be zero depending on the cell size or, in other words, on the length of the cyclic shift.

In a third scheme, signatures are allocated from the same root index using different time/frequency resources. The same code resources are used for dedicated and random signatures. In this scheme,
20 contention-based and contention-free RACH signature opportunities are allocated from the same cyclic shifted versions over the same ZC sequences index.

An advantage of the third scheme is that no additional ZC indexes are required or, in other words, there is no need to use a new root
25 sequence. A disadvantage of the third scheme is that the distinction

between contention-free and contention-based preambles is made by the time/frequency resources used for RACH since there is no code distinction between contention-free and contention-based preambles, thereby requiring additional signaling.

5 In a fourth scheme, signatures are allocated from the same root index using the same time/frequency resources. This scheme consists of allowing the reservation of some preambles from the set of preambles used for the contention-based random access procedure in a semi-static way. For example, 16 preambles could be reserved. An inconvenience
10 of the fourth scheme is a decreased number of available preambles for non-contention based RACH, thereby increasing the collision probability.

A preferred scheme is a hybrid between the second and fourth schemes. This hybrid scheme considers the advantages and disadvantages of the
15 four schemes in order to minimize interferences introduced by the use of new root sequences and signaling.

The hybrid scheme allocates the dedicated signatures from the unused space of the random signature root index when there is unused space. The fourth scheme is utilized if more dedicated signatures are needed
20 and some preambles are reserved from the contention-based random access preambles. The number of signatures that may be reserved among the contention-based signature sets is predetermined.

FIG. 4 illustrates dedicated signature allocation according to the present invention. In FIG. 4, it is assumed that the UE 10 knows
25 the root sequences and cyclic shift value used in the cell where it

will use the dedicated signature and that the hybrid method is used for the allocation of dedicated signatures.

One way to indicate to the UE 10 which signature has been reserved for its use is to simply indicate a number out of the total number of available signatures such that the UE knows how many cyclic shifts it will have to apply in order to generate the signature. The total number of available signatures is the number of signatures that can be generated from all the root sequences used in a given cell. The UE 10 will implicitly know that it must apply the cyclic shifts to root sequence #B if the number of cyclic shifts is higher than the max number of cyclic shifts applicable on root sequence #A.

However, this method requires that the eNB 20 send at least 6 bits of information to the UE 10. There are several options for optimizing the method. For all the options, the number of signatures that are reserved must be indicated to the UEs 10 that perform contention-based access, such as by being broadcast on the BCCH.

A first option for allocating dedicated signatures is to reduce the number of information bits to less than 6 bits is by defining in the standard that the signature for the contention-based random access for which reservation is allowed are the last signatures generated from the root sequence and to start numbering from the end, as illustrated by the arrow in FIG. 4(a).

The first option is dependent on the number of signatures that can be reserved, such as only 4 bits being necessary if the number of signatures that can be reserved is fixed at 16. For example, the

eNB 20 may reserve signature 64 and send the information "3" to the UE 10. As illustrated in FIG. 4(a), 3 unused signatures are available. The first option requires that the space on the ZC index for reserved signatures be contiguous and located at the end of the index before
5 the unused space.

One disadvantage of the first option is that all the signatures that can be reserved are from the same set and, therefore, the UE 10 cannot choose a set, such as to indicate the required resources/channel quality. The first option also reduces the number
10 of signatures available for contention-based only in one set and increases the collision probability for only one category of users.

A second option for allocating dedicated signatures addresses the disadvantages of the first option. The second option allocates the dedicated signatures between the two sets of signatures proportionally
15 to the size of the set instead of allocating the reserved signatures at the end of the index from among the 64 signatures used for the contention-based random access.

For example, if N_r signatures can be reserved among the 64 contention-based random access signatures, those signatures are
20 reserved between the two sets such that one part will be at the end of the first set and the other part at the beginning of the second set. The number of signatures reserved in each of the two sets can be calculated according to the following equation:

$$\begin{aligned} NR_{set1} &= \text{ceil} (N_{set1} / 64 * (N_r - N_{unused})) \text{ and } NR_{set2} = N_r \\ &- NR_{set1} - N_{unused} \end{aligned}$$

25

Where:

Nset1 the number of signatures in set 1

Nset2 the number of signatures in set 2

5 Nunused is the number of signatures that are not used in
the root sequences

NRset1 the number of reserved signatures in set 1

NRset2 the number of reserved signatures in set 2

Ceil indicates integer (upper integer)

10 There are two alternatives to indicate to the UE 10 which signature
to use for the second option. The first alternative is the less
optimized alternative and indicates the signature with a number from
6 to 8 bits, with the upper bound predetermined depending on the number
of signatures available in the unused space of the ZC index.

15 The second alternative, which is illustrated in FIG. 4 (b), consists
of sending offset information to indicate the signature to use, with
the number of bits of the offset information dependent on the number
of signatures that can be reserved. For example, 4 bits would be
required if 16 signatures are dedicated without any unused space.
The counting would be done from the first reservable signature of
20 set 1 in FIG. 4 (b) toward the last reservable signature of set 2 or
from the end of the index toward the beginning of the sequence if
the signature comes from the unused space of an index.

25 The UE 10 must choose between signatures in two groups in the second
option for allocating dedicated signatures, as illustrated in FIG.
4 (b). In order to optimize the resource allocation for the transmission

of data in message3 illustrated in FIG. 3, the UE 10 can be assigned a signature according to the required resources, such that the eNB 20 indicates to the UE the transport format to be used in message 3 together with the dedicated signature.

5 An advantage of this option for choosing a dedicated signature is that the eNB 20 designates only one signature. A disadvantage of this option is that the size of message3 illustrated in FIG. 3 must accommodate the assigned signature.

An alternative option for choosing the dedicated signature is that
10 the eNB 20 reserves two signatures each time, one from each signature set, such that the UE 10 chooses the signature according to the amount of data it must transmit. The eNB 20 should indicate for which transport formats of message3 illustrated in FIG. 3 and/or radio conditions the UE10 could use each reserved dedicated signature. The disadvantage
15 of this option is that two signatures must be reserved.

FIG. 5 illustrates a block diagram of a mobile station (MS) or
UE 10. The UE 10 includes a processor (or digital signal processor)
510, RF module 535, power management module 505, antenna 540, battery
555, display 515, keypad 520, memory 530, SIM card 525 (which may
20 be optional), speaker 545 and microphone 550.

A user enters instructional information, such as a telephone number,
for example, by pushing the buttons of a keypad 520 or by voice activation
using the microphone 550. The microprocessor 510 receives and
processes the instructional information to perform the appropriate
25 function, such as to dial the telephone number. Operational data may

be retrieved from the Subscriber Identity Module (SIM) card 525 or the memory module 530 to perform the function. Furthermore, the processor 510 may display the instructional and operational information on the display 515 for the user's reference and convenience.

5 The processor 510 issues instructional information to the RF module 535, to initiate communication, for example, transmits radio signals comprising voice communication data. The RF module 535 comprises a receiver and a transmitter to receive and transmit radio signals. An antenna 540 facilitates the transmission and reception of radio
10 signals. Upon receiving radio signals, the RF module 535 may forward and convert the signals to baseband frequency for processing by the processor 510. The processed signals would be transformed into audible or readable information outputted via the speaker 545, for example. The processor 510 also includes the protocols and functions necessary
15 to perform the various processes described herein.

Depending on implementation, it is possible that the present invention can take the form of an entirely hardware embodiment, an entirely software embodiment or an embodiment containing both hardware and software elements. A software embodiment may include, but not
20 be limited to, to firmware, resident software, microcode, etc.

Furthermore, the invention can take the form of a computer program product accessible from a computer-usable or computer-readable medium providing program code for use by or in connection with a computer or any instruction execution system. For the purposes of this
25 description, a computer-usable or computer readable medium can be

any apparatus that can contain, store, communicate, propagate, or transport the program for use by or in connection with the instruction execution system, apparatus, or device.

A data processing system suitable for storing and/or executing
5 program code will include at least one processor coupled directly or indirectly to memory elements through a system bus. The memory elements can include local memory employed during actual execution of the program code, bulk storage, and cache memories which provide temporary storage of at least some program code in order to reduce
10 the number of times code must be retrieved from bulk storage during execution.

Other components may be coupled to the system. Input/output or I/O devices (including but not limited to keyboards, displays, pointing devices, etc.) can be coupled to the system either directly or through
15 intervening I/O controllers. Network adapters (e.g., modem, cable modem, Ethernet cards) may also be coupled to the system to enable the data processing system to become coupled to other data processing systems or remote printers or storage devices through intervening private or public networks.

20 It should be understood that the logic code, programs, modules, processes, methods, and the order in which the respective elements of each method are performed are purely exemplary. Depending on the implementation, they may be performed in any order or in parallel, unless indicated otherwise in the present disclosure. Further, the
25 logic code is not related, or limited to any particular programming

language, and may be comprise one or more modules that execute on one or more processors in a distributed, non-distributed, or multiprocessing environment.

The method as described above may be used in the fabrication of
5 integrated circuit chips. The resulting integrated circuit chips can be distributed by the fabricator in raw wafer form (that is, as a single wafer that has multiple unpackaged chips), as a bare die, or in a packaged form. In the latter case, the chip is mounted in a single
10 chip package (such as a plastic carrier, with leads that are affixed to a motherboard or other higher level carrier) or in a multi-chip package (such as a ceramic carrier that has either or both surface interconnections of buried interconnections).

In any case, the chip is then integrated with other chips, discrete circuit elements, and/or other signal processing devices as part of
15 either (a) an intermediate product, such as a motherboard, or (b) and end product. The end product can be any product that includes integrated circuit chips, ranging from toys and other low-end applications to advanced computer products having a display, a keyboard or other input device, and a central processor.

20 Therefore, it should be understood that the invention can be practiced with modification and alteration within the spirit and scope of the appended claims. The description is not intended to be exhaustive or to limit the invention to the precise form disclosed. These and various other adaptations and combinations of the embodiments
25 disclosed are within the scope of the invention and are further defined

by the claims and their full scope of equivalents.

As the present invention may be embodied in several forms without departing from the spirit or essential characteristics thereof, it should also be understood that the above-described embodiments are
5 not limited by any of the details of the foregoing description, unless otherwise specified, but rather should be construed broadly within its spirit and scope as defined in the appended claims. Therefore, all changes and modifications that fall within the metes and bounds of the claims, or equivalence of such metes and bounds are intended
10 to be embraced by the appended claims.

The foregoing embodiments and advantages are merely exemplary and are not to be construed as limiting the present invention. The present teaching can be readily applied to other types of apparatuses.

The description of the present invention is intended to be
15 illustrative, and not to limit the scope of the claims. Many alternatives, modifications, and variations will be apparent to those skilled in the art. In the claims, means-plus-function clauses are intended to cover the structure described herein as performing the recited function and not only structural equivalents but also
20 equivalent structures.

【Industrial Applicability】

The present invention is directed to different methods for allocating and choosing dedicated signatures for random access.

【CLAIMS】**【Claim 1】**

A method of requesting a random access connection between a wireless mobile terminal and a base station, the method comprising:

5 receiving information comprising at least one signature root sequence index, a cyclic shift parameter and a signature set identifier representing a boundary between a first signature set corresponding to a first transport format and a second signature set corresponding to a second transport format; and

10 preparing random access signatures according to the at least one signature root sequence index and the cyclic shift parameter, wherein at least one of the random access signatures is associated with the first signature set and the rest of the random access signatures are associated with the second signature set.

15 【Claim 2】

The method of claim 1, wherein the signature set identifier comprises a plurality of steps, each of the plurality of steps comprising a plurality of signatures.

【Claim 3】

20 The method of claim 1, wherein the signature set identifier comprises one of a plurality of predefined borders between the first signature set and second signature set.

【Claim 4】

A mobile terminal for requesting a random access connection
25 with a base station, the mobile terminal comprising:

a transmitting unit for transmitting information;
a receiving unit for receiving information;
a display unit for displaying information;
an input unit for receiving inputs from a user; and

5 a processing unit processing received information comprising at least one signature root sequence index, a cyclic shift parameter and a signature set identifier representing a boundary between a first signature set corresponding to a first transport format and a second signature set corresponding to a second transport format, and preparing
10 random access signatures according to the at least one signature root sequence index and the cyclic shift parameter,

wherein at least one of the random access signatures is associated with the first signature set and the rest of the random access signatures are associated with the second signature set.

15 **【Claim 5】**

The mobile terminal of claim 4, wherein the signature set identifier comprises a plurality of steps, each of the plurality of steps comprising a plurality of signatures.

【Claim 6】

20 The mobile terminal of claim 4, wherein the signature set identifier comprises one of a plurality of predefined borders between the first signature set and second signature set.

FIG. 1

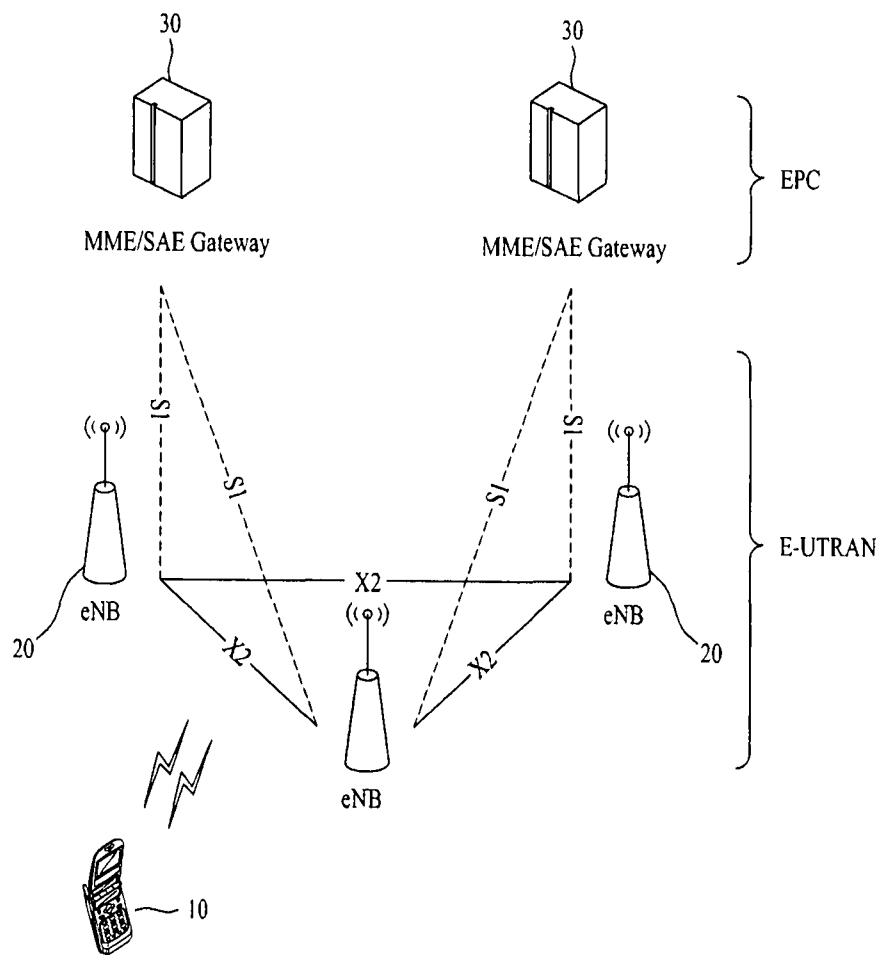

FIG. 2A

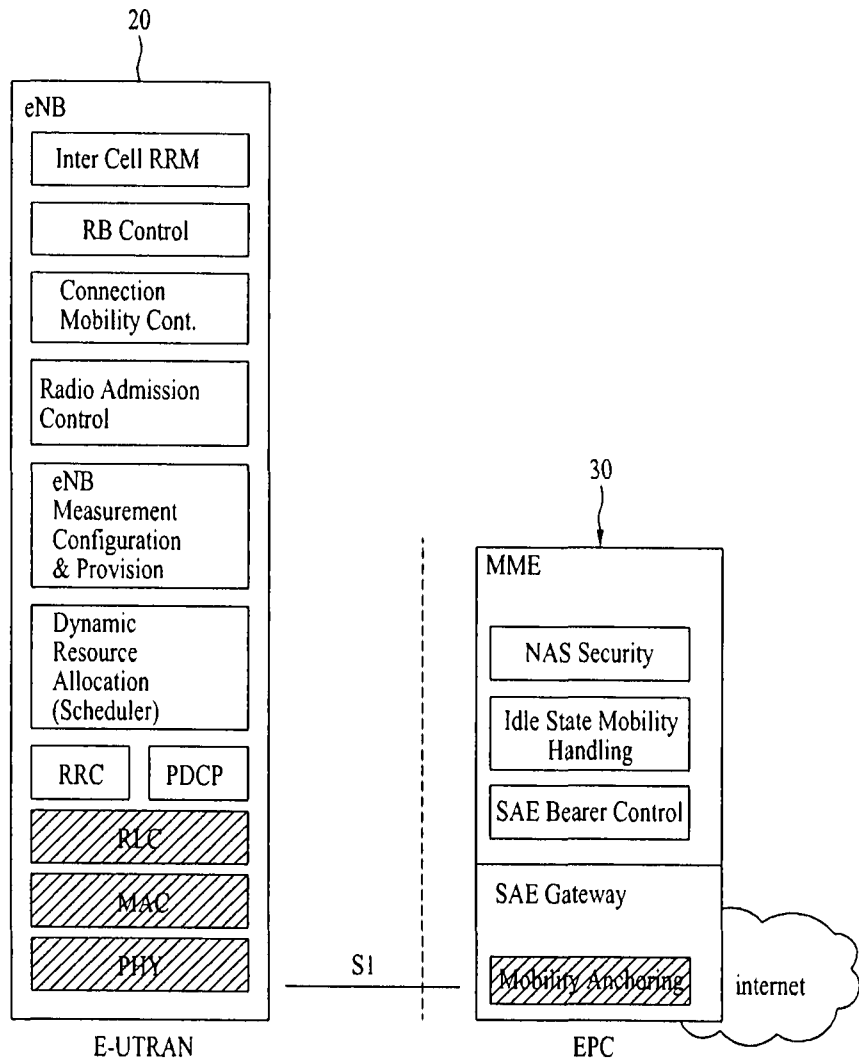

FIG. 2B

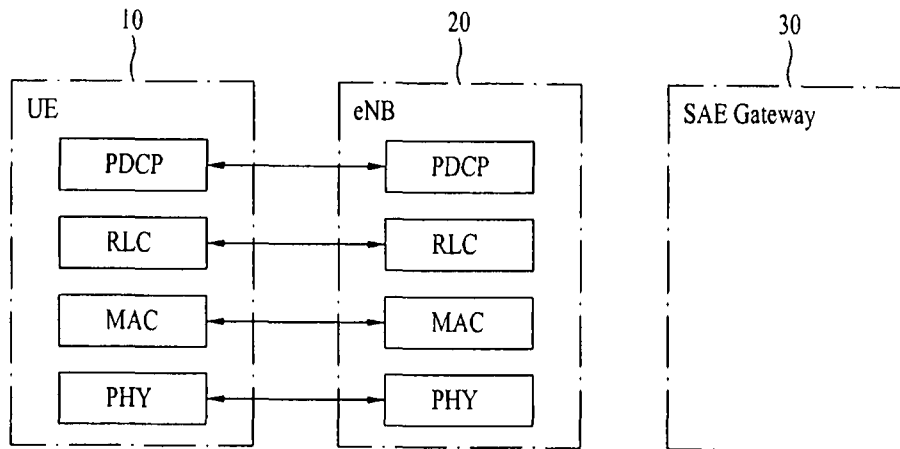

FIG. 2C

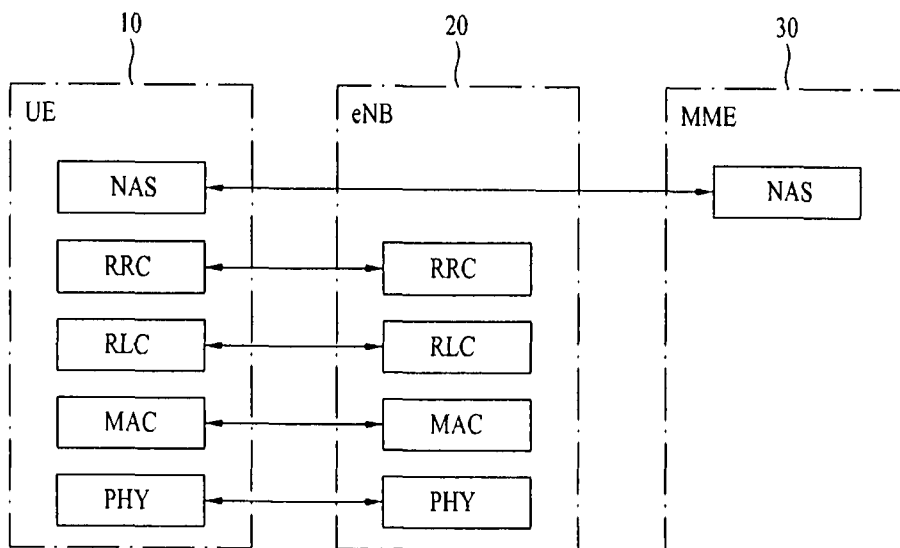
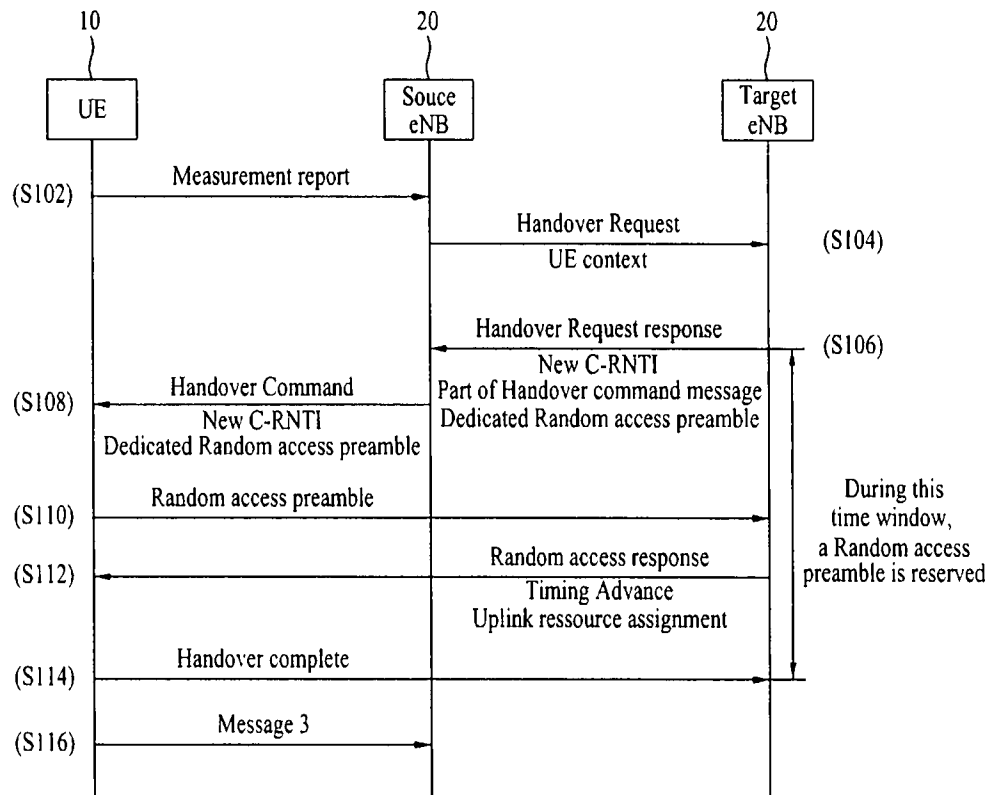
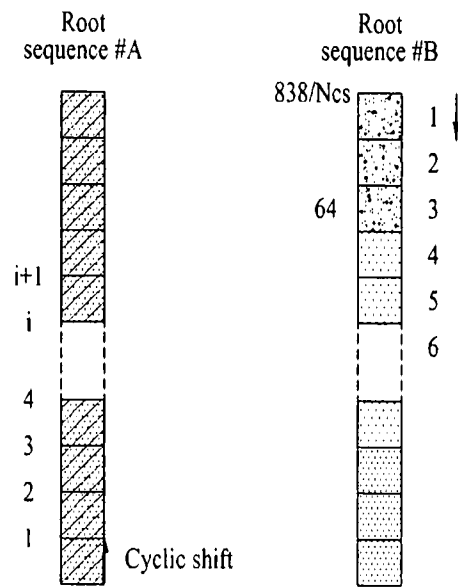

FIG. 3



5/7

FIG. 4A



Option 1





- | | | | |
|---|---|---|-----------------------|
|  | Signature for the contention based Random access |  | Signatures from set 1 |
|  | Unused space of the root index. Signature available for reservation |  | Signatures from set 2 |
|  | Signature for the contention based Random access for which reservation is allowed | | |

FIG. 5

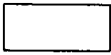