

April 25, 1961

M. W. HEISTERBERG

2,981,438

FLOATING ROOF SEALING MECHANISM PROVIDED WITH
COMBINATION WEATHER HOOD AND WAX TROUGH

Filed Feb. 19, 1959

2 Sheets-Sheet 1

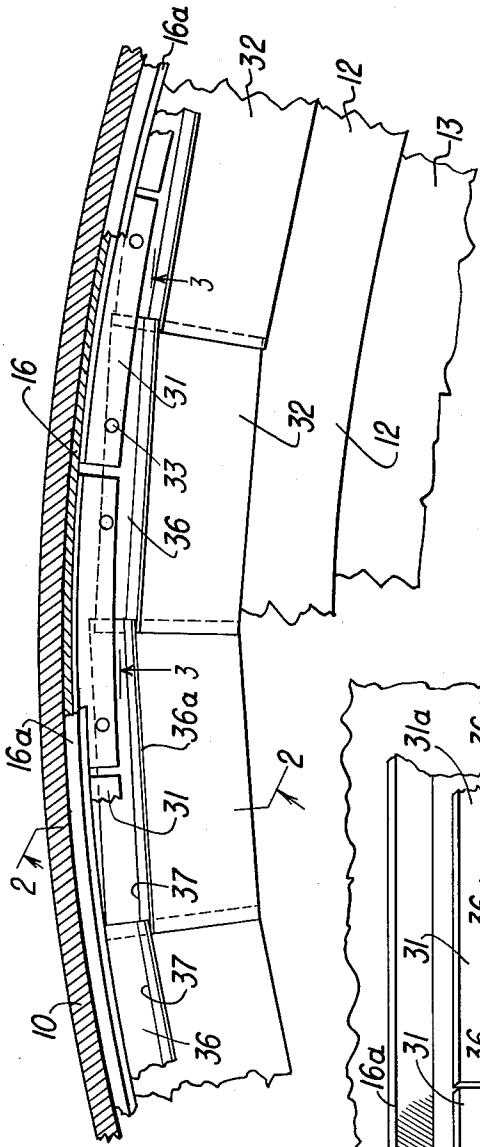

Fig. 1

Fig. 3

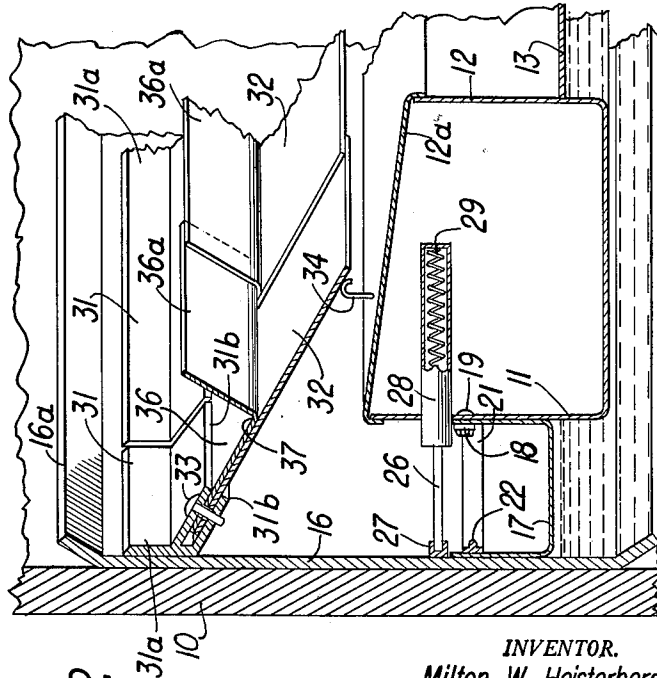
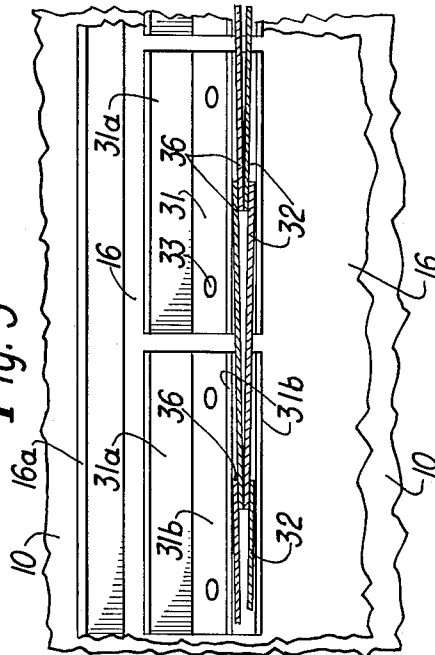

Fig. 2

INVENTOR.

Milton W. Heisterberg

BY

Brangley, Baird, Clayton, Miller & Vogel
Attys.

April 25, 1961

M. W. HEISTERBERG

2,981,438

FLOATING ROOF SEALING MECHANISM PROVIDED WITH
COMBINATION WEATHER HOOD AND WAX TROUGH

Filed Feb. 19, 1959

2 Sheets-Sheet 2

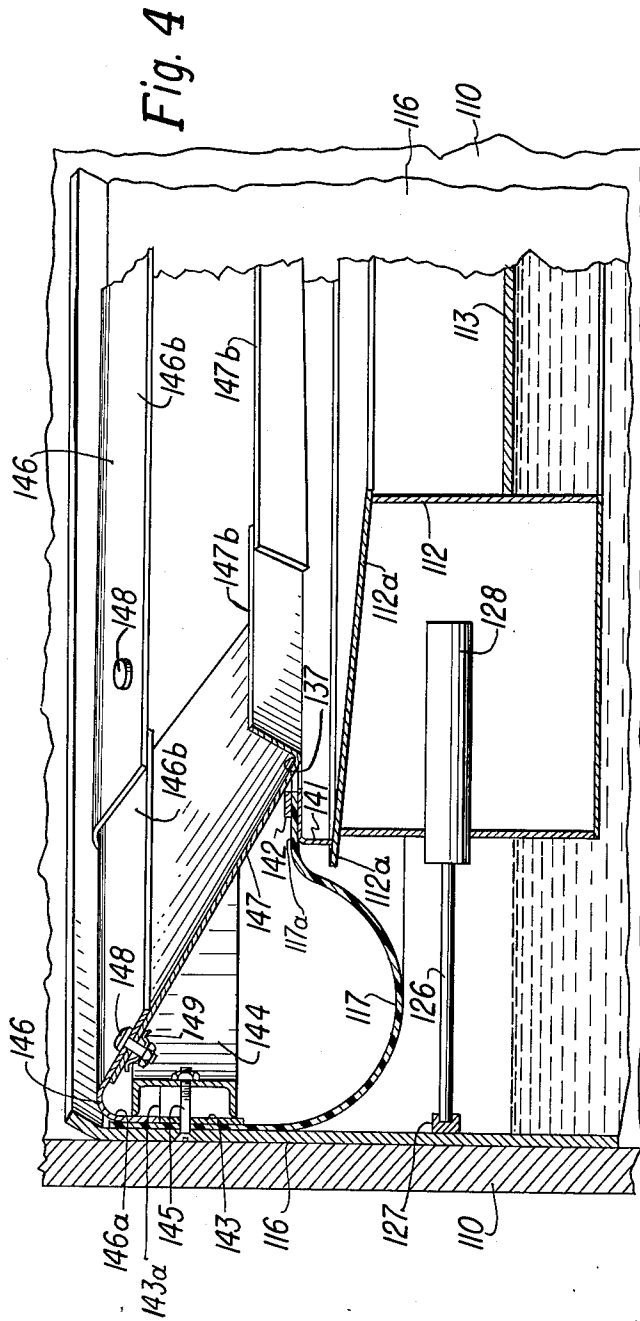

Fig. 4

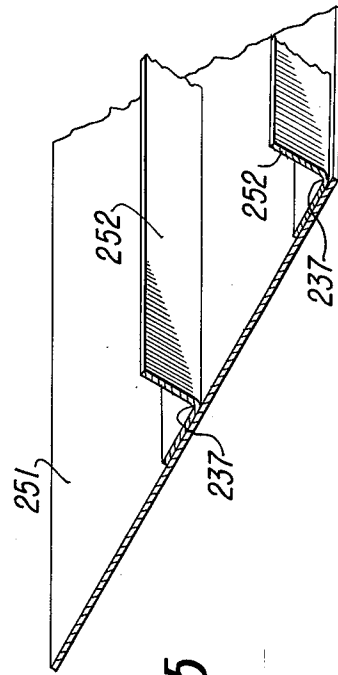

Fig. 5

INVENTOR.

Milton W. Heisterberg

BY

Prangley, Baird, Clayton, Miller & Vogel
Attys.

1

2,981,438

FLOATING ROOF SEALING MECHANISM PROVIDED WITH COMBINATION WEATHER HOOD AND WAX TROUGH

Milton W. Heisterberg, Chicago Heights, Ill., assignor to General American Transportation Corporation, Chicago, Ill., a corporation of New York

Filed Feb. 19, 1959, Ser. No. 794,454

4 Claims. (Cl. 220—26)

This invention relates to storage tanks employing floating roofs and used for the storage of liquids in the oil industry and elsewhere and more particularly designed for use with liquids having a congealable constituent which at some times may be present in either liquid or congealed form due to different temperature conditions.

For example, in crude oils certain waxy products, under certain temperature conditions, congeal on the inside of the tank wall in position to be scraped off by the sealing structure provided between the floating roof and the tank wall so as to fall inwardly either onto the sealing structure or else onto the protective covering for the seal. Where no provision is made for closing the gap between the floating roof and the tank wall, the flexible sealing structure between the floating roof and the tank wall will receive the wax and become clogged thereby so as to cause subsequent damage. When a protective seal cover is provided and the wax is hot from the sun, this waxy product may flow onto the roof and into the drains and subsequently congeal and clog them, or may spread and make a slippery coating on the roof. In either case, the waxy product is lost from the lading in the tank.

One of the principal objects of the present invention is to provide a storage tank employing a floating type roof wherein any waxy product which congeals and is scraped off the side wall of the tank, will be trapped and held before it reaches as portion of the roof or seal structure where it can cause damage or danger, for example, because of the safety hazard of a slippery deck, or because of the fire hazard of widely spread combustible material.

Another object of the invention is to provide a trapping structure which can be incorporated readily in existing tanks and floating roof structures, and also one which is of a flexible character so as to accommodate itself to variations in dimensions of the tank wall and the seal structure associated therewith.

These and other objects and advantages of the present invention will be apparent from the following description of certain preferred embodiments thereof, taken in connection with the accompanying drawings, wherein:

Figure 1 is a fragmentary plan view of a peripheral portion of the floating tank roof constructed in accordance with the invention, the tank wall being shown in cross section, and the shoe of the seal being also partially shown in cross section;

Figure 2 is a fragmentary vertical cross sectional view of the roof and tank taken substantially along the line 2—2 of Figure 1;

Figure 3 is a fragmentary elevational view, partially in cross section, taken as indicated by the line 3—3 in Figure 1;

Figure 4 is a fragmentary vertical cross sectional view of the roof and tank, generally similar to the view shown in Figure 2, but illustrating a modified form of the invention; and

Figure 5 is a fragmentary perspective view of the trap structure illustrating a further modification thereof.

2

Referring to Figures 1, 2 and 3 of the drawings, the wall 10 illustrates the upstanding side wall of an open top cylindrical tank of the type commonly used for storing liquids, and particularly liquid petroleum products such as crude oils.

The liquid level 11 in the tank is expected to rise and fall from time to time, and the roof of the present invention is arranged to float on the liquid and to rise and fall with the changes in the liquid level, being commonly designated as a floating roof of the pontoon type. The roof includes at its outer periphery a pontoon 12 having an upper wall 12a which slopes downwardly and inwardly from its outer edge. Extending inwardly from the pontoon 12, is a deck 13 which may or may not include another pontoon at the center of the tank in accordance with the particular type of roof being constructed.

The annular outer pontoon 12 is spaced from the wall 10 of the tank, and a seal is preferably provided in this space and this seal mechanism may comprise an outer sliding cylindrical metal shoe 16 of a flexible nature to conform to irregularities in the tank wall 10, and an annular flexible gas impervious curtain or fabric seal 17 which is clamped to the outer wall of the pontoon 12 by a seal bar 18, and by a plurality of nut and bolt connections 19 to provide a gas tight joint. The outer periphery of the fabric seal 17 is clamped by a seal bar 21 and a plurality of nut and bolt connections 22 to also provide a gas tight joint.

At a plurality of points about the periphery of the floating roof structure, pressure and supporting rods 26 are provided, each having a channel piece 27 at the outer end thereof secured to the shoe 16. Each rod 26 is slidably engaged within a pipe or a cylinder 28 supported on the outer wall of the pontoon 12 and having a compression spring 29 housed therein. This structure provides a yieldable pusher mechanism which serves to support the shoe 16 and also to urge it against the tank wall 10.

An annular cover structure or weather hood is provided between the sliding shoe 16 and the pontoon 12 to protect the parts of the seal and to cover the open space between the pontoon 12 and the shoe 16 so as to drain onto the pontoon 12 and the deck 13 rain and other moisture that would otherwise fall into this space. For this purpose an annular series of brackets 31 are secured to the inner surface of the shoe 16 adjacent its upper inturned edge 16a and each bracket 31 includes an upstanding flange 31a secured flush against the shoe 16, and is provided adjacent its lower edge with a pair of inwardly and downwardly directed flanges 31b, which are spaced apart to receive the outer edges of an annular series of overlapped cover plates 32, which are loosely secured in place by headed pins 33, extending through suitable apertures in the flanges 31b and the plates 32. The inner edges of these plates 32 are supported in spaced relation from the pontoon 12 by suitable supports 34. By providing a sectional annular cover plate structure, with the sections or plates in overlapping relation, a weather-tight closure is provided which also accommodates itself to changes in contour of the shoe as it follows any irregularities in the tank wall.

Means are provided for collecting any congealed products such as waxes which are deposited on the inner surface of the tank wall 10 and scraped loose therefrom by movement of the shoe 16, and this means preferably comprises an annular shallow trough structure of flexible character, which will retain the waxes while permitting overflow of any rain water or the like. This annular trough structure is comprised of overlapped bent plates 36 which have their outer edges disposed between the respective flanges 31b of the brackets 31, and have suitable apertures to receive the pins 33 so as to be secured in place easily by existing structure. These plates 36 provide a trough 37 formed by an upturned inner edge 36a of each plate 36.

From the above description it will be seen that the trough 37 provides for satisfactory retention of waxy products, even when melted, as their more or less viscous nature would preclude any appreciable loss through the cracks or spaces provided between the overlapped plates 36. At the same time this trough structure is not water tight because water will seep more or less easily through these cracks or crevices, or if received in volume will flow over the up-turned edges 36a.

Referring to Figure 4 there is illustrated a modified form of seal structure for a floating roof of the type described herein together with a modified form of annular weather hood and trap structure for the waxy products. In this form of the invention, the flexible fabric seal 117 is supported between the upper surface of the pontoon 112 and the upper portion of the sliding shoe 116. The inner edge 117a of the flexible fabric seal 117 is disposed horizontally on top of a channel-shaped mounting member 141 secured about the upper surface 112a of the pontoon 112, being secured in place by an annular seal bar 142 suitably secured to the upper flange of the channel-shaped member 141. The outer peripheral edge of the fabric seal 117 is disposed between the shoe 116 and an annular seal bar 143 clamped in place by a retaining channel 144 secured to the shoe 116 by a plurality of bolt and nut structures 145. The retaining or clamping channel 144 also provides means for securing in place an annular series of adapter strips 146 which have their outer down-turned flanges 146a in engagement with the top 143a of the seal bar 143, and secured by one web of the channel 144 against the upper edge of the fabric seal 117. Each strip 146 extends upwardly from its outer flange 146a and then curves inwardly and downwardly therefrom to provide an inwardly and downwardly projecting inner flange 146b which provides a mounting means for the weather hood and trap structure plates 147 which extend inwardly and downwardly therefrom to rest on the seal bar 142. The inner flanges 146b and the plates 147 are suitably apertured to receive loosely a series of securing bolt and nut constructions 148 having spring washer retainers 149 of conventional construction. The adapters 146 are overlapped one upon the other as seen in Figure 4, and the weather hood and trap plates 147 are similarly overlapped, having their inner edges upturned at 147b, to form a trough or trap 137, which overlies the upward inwardly sloping top 112a of the pontoon 112.

This structure serves not only to convey any precipitation received onto the pontoon 112 and thence to the roof structure to be accommodated by conventional drainage means of the tank, but also provides a trap for the waxy products scraped loose from the tank wall 110 by the shoe 116 and to retain these waxy products for subsequent removal and return to the lading of the tank.

Figure 5 shows in fragmentary fashion a trap structure which comprises an inclined plate 251 which may be similar to either of the types shown in Figures 2 or 4, and which has secured thereon a plurality of angle-shaped trap members 252 to form a series of traps 237 for the waxy products, these plates 251 being overlapped and mounted in the general fashion shown in either of Figures 2 or 4. In this embodiment, the composite trap structure comprises the two concentric low annular riffles provided by the members 252 for the purpose of selectively trapping the waxy products, while accommodating the spill-over of rain water onto the top surface of the adjacent supporting pontoon and the consequent delivery of the rain water to the associated deck for the ultimate drain purpose.

It will be noted that in all the modifications shown herein an annular flexible trap structure is shown of a shallow nature which will accommodate the waxy products without permitting overflow thereof, when liquid, onto the floating roof, but which will permit passage of precipitated rain or other moisture onto the tank roof for disposal. In this way the seal structure is protected, and the safety hazard of a tank roof made slippery by wax is eliminated,

as well as the fire hazard of a widely spread combustible material. Also, a large percentage of the waxy product which may be removed from the tank wall is available for return to the lading of the tank, thereby retaining closely its original constituents for subsequent processing.

The foregoing description of certain embodiments of the present invention has been made for clearness of understanding only and no unnecessary limitations are intended thereby, for it will be apparent to those skilled in the art that various modifications may be made in the present tank structure within the sphere and scope of the appended claims.

What is claimed is:

1. In combination with an upstanding substantially cylindrical tank for storage of liquid petroleum products, a substantially annular floating roof for said tank that rests on the stored petroleum products and that rises and falls as the amount of the stored petroleum product varies, and a substantially annular peripheral seal carried by said roof and extending radially outward therefrom to the side wall of said tank and including a substantially annular shoe pressed radially outwardly against said side wall and having sufficient flexibility to conform to the configuration of said side wall, whereby said shoe scrapes waxy constituents off of said side wall; and a weather hood carried by said shoe and including a plurality of downwardly and inwardly inclined shingle-like plates arranged in an annular array over said seal with the side edges thereof in overlapping relation between said shoe and roof thus constituting a water shed onto said roof, and said hood including a plurality of upwardly directed projections arranged in annular array with the side edges thereof in overlapping relation between said shoe and roof and defining a substantially annular trap wall against which waxy constituents scraped from said tank wall may accumulate and over which water may flow and shed onto said roof.

2. The storage tank combination set forth in claim 1, in which an annular series of mountings are on said flexible shoe, and said overlapping plates and projections are so interrelated and carried by said mountings as to accommodate changes in contour of said flexible shoe as it follows the tank wall.

3. In combination with an upstanding substantially cylindrical tank for storage of liquid petroleum products, a substantially annular floating roof for said tank that rests on the stored petroleum products and that rises and falls as the amount of the stored petroleum product varies, and a substantially annular peripheral seal carried by said roof and extending radially outward therefrom to the side wall of said tank and including a substantially annular shoe pressed radially outwardly against said side wall and having sufficient flexibility to conform to the configuration of said side wall, whereby said shoe scrapes waxy constituents off of said side wall; and a weather hood carried by said shoe and including a plurality of downwardly and inwardly inclined shingle-like plates arranged in an annular array over said seal with the side edges thereof in overlapping relation between said shoe and roof thus constituting a water shed onto said roof, said annular array of plates being in upper and lower superimposed annular series in which the side edges of the adjacent plates forming the individual series are in overlap with each other, said plates in said upper series including upwardly directed projections arranged in annular array and having side edges in overlapping relation thus defining a substantially annular trap wall against which waxy constituents scraped from said tank wall may accumulate and over which water may flow and shed onto said roof, said trap wall being in advance of the lower ends of said plates of said lower series of plates along the water shed.

4. In combination with an upstanding substantially cylindrical tank for storage of liquid petroleum products, a substantially annular floating roof for said tank that rests on the stored petroleum products and that rises and

5

falls as the amount of the stored petroleum product varies, and a substantially annular peripheral seal carried by said roof and extending radially outward therefrom to the side wall of said tank and including a substantially annular shoe pressed radially outwardly against said side wall and having sufficient flexibility to conform to the configuration of said side wall, whereby said shoe scrapes waxy constituents off of said side wall; and a weather hood including a plurality of downwardly and inwardly inclined shingle-like plates carried by said shoe and arranged in an annular array over said seal with the side edges thereof in overlapping relation between said shoe and roof thus constituting a water shed onto said roof,

6

and the lower ends of said plates including upwardly directed overlapping projections defining a substantially annular trap wall against which waxy constituents scraped from said tank wall may accumulate and over which water may flow and shed onto said roof.

References Cited in the file of this patent

UNITED STATES PATENTS

10	1,931,551	Larson -----	Oct. 24, 1933
	2,754,026	Wiggins -----	July 10, 1956
	2,802,591	Wiggins -----	Aug. 13, 1957
	2,855,122	Ulm et al. -----	Oct. 7, 1958