



INTERNATIONAL APPLICATION PUBLISHED UNDER THE PATENT COOPERATION TREATY (PCT)

<p>(51) International Patent Classification ⁶ : H04L 12/56</p>	<p>A2</p>	<p>(11) International Publication Number: WO 96/13108 (43) International Publication Date: 2 May 1996 (02.05.96)</p>
<p>(21) International Application Number: PCT/IB95/01027 (22) International Filing Date: 24 October 1995 (24.10.95) (30) Priority Data: 08/328,513 25 October 1994 (25.10.94) US (71) Applicant: CABLETRON SYSTEMS, INC. [US/US]; 35 Industrial Way, Rochester, NH 03867 (US). (72) Inventors: AGGARWAL, Ajay; 601 Tri City Road, Somersworth, NH 03878 (US). SCOTT, Walter; 6 Lansing Drive, Salem, NH 03079 (US). RUSTICI, Eric; 1 Wyandot Circle, Londonderry, NH 03053 (US). BUCCIERO, David; 12 Hillside Drive, Nashua, NH 03060 (US). HASKINS, Andrew; 11 Riverside Rarm Drive, Lee, NH 03824 (US). MATTHEWS, Wallace; 12 Hall Place, Exeter, NH 03833 (US). (74) Agent: HENDRICKS, Therese, A.; Wolf, Greenfield & Sacks, P.C., 600 Atlantic Avenue, Boston, MA 02210 (US).</p>		<p>(81) Designated States: AU, JP, European patent (AT, BE, CH, DE, DK, ES, FR, GB, GR, IE, IT, LU, MC, NL, PT, SE). Published <i>Without international search report and to be republished upon receipt of that report.</i></p>

(54) Title: **METHOD AND APPARATUS FOR DETERMINING IP COMMUNICATIONS PATH**

(57) Abstract

Method and apparatus for determining a data path between source (11) and destination (12) IP devices. A TTL mechanism is used, in combination with loose-source routing, to incrementally discover the routers on the path, wherein the querying node (13) sending the UDP probe packets need not be the source node. Once an intermediate router on the path is known which can communicate via SNMP, an SNMP query may be sent to determine the next-hop router from the IP routing table. If this fails, the method reverts to the incrementing TTL mechanism.

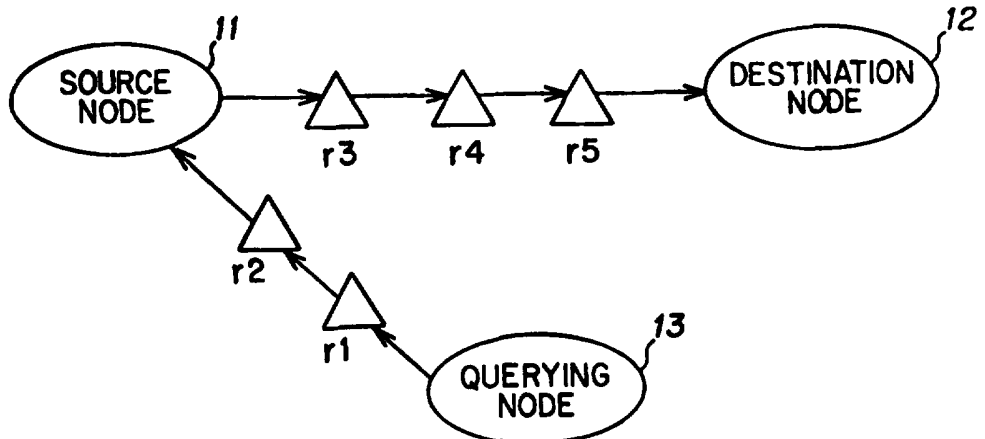

FOR THE PURPOSES OF INFORMATION ONLY

Codes used to identify States party to the PCT on the front pages of pamphlets publishing international applications under the PCT.

AT	Austria	GB	United Kingdom	MR	Mauritania
AU	Australia	GE	Georgia	MW	Malawi
BB	Barbados	GN	Guinea	NE	Niger
BE	Belgium	GR	Greece	NL	Netherlands
BF	Burkina Faso	HU	Hungary	NO	Norway
BG	Bulgaria	IE	Ireland	NZ	New Zealand
BJ	Benin	IT	Italy	PL	Poland
BR	Brazil	JP	Japan	PT	Portugal
BY	Belarus	KE	Kenya	RO	Romania
CA	Canada	KG	Kyrgystan	RU	Russian Federation
CF	Central African Republic	KP	Democratic People's Republic of Korea	SD	Sudan
CG	Congo	KR	Republic of Korea	SE	Sweden
CH	Switzerland	KZ	Kazakhstan	SI	Slovenia
CI	Côte d'Ivoire	LI	Liechtenstein	SK	Slovakia
CM	Cameroon	LK	Sri Lanka	SN	Senegal
CN	China	LU	Luxembourg	TD	Chad
CS	Czechoslovakia	LV	Larvia	TG	Togo
CZ	Czech Republic	MC	Monaco	TJ	Tajikistan
DE	Germany	MD	Republic of Moldova	TT	Trinidad and Tobago
DK	Denmark	MG	Madagascar	UA	Ukraine
ES	Spain	ML	Mali	US	United States of America
FI	Finland	MN	Mongolia	UZ	Uzbekistan
FR	France			VN	Viet Nam
GA	Gabon				

- 1 -

METHOD AND APPARATUS FOR DETERMINING
IP COMMUNICATIONS PATH

Field of the Invention

5 This invention relates to computer network communication systems, and in particular to a method and apparatus for determining data paths on an IP network.

Background of the Invention

10 In an Internet, several networks are connected together through the use of gateways and an internetworking protocol. The gateways (often called routers), using the protocol, hide the underlying details of the actual networks, in order to provide uniform service across the network.

15 The leading internetworking technology is the Internet suite of protocols, commonly referred to as TCP/IP, after the two-core protocols in the suite. TCP, the transmission control protocol, is a connection-oriented transport service. IP, the Internet protocol, is a connectionless-mode network service.

20 IP is called a connectionless-mode network protocol, which means that it is datagram-oriented. When some entity on the network wishes to send data using IP, it sends that data as a series of datagrams. Associated with each datagram is an address indicating where the datagram should be delivered. This
25 address consists of an IP address, an upper-layer protocol number. IP takes the user-data and encapsulates it in an IP datagram, which contains all of the information necessary to deliver the datagram to the IP entity at the destination. The remote IP entity will examine the IP datagram it receives, and
30 then strip off the data and pass it up to the appropriate upper-layer protocol. See, M. Rose, "The Simple Book - An Introduction To Management Of TCP/IP-Based Internets," Prentice Hall, 1991.

 SNMP, Simple Network Management Protocol, has become
35 the de facto operational standard for network management of TCP/IP-based internets. A managed network may be considered as consisting of three components: (1) several managed nodes, each containing an agent; (2) at least one network management station

- 2 -

(NMS); and (3) a network management protocol, which is used by the station and the agents to exchange management information. The managed node may consist of a host system, e.g., workstation, terminal server, or printer; a gateway system, e.g., a router; or a media device, e.g., a bridge, hub or multiplexor. One activity of the network management system is to compile a topology of the network, defining the connections between various devices on the network. The network management system may query the IP routing table at each gateway, to determine what devices are located at each port on the gateway. This information may be used to construct a data path between any two devices on the internet.

Associated with IP is another protocol providing low-level feedback about how the internet layer is operating. This protocol is termed the "Internet Control Method Protocol" (ICMP). ICMP provides basic control messages for error reporting.

One useful tool in troubleshooting connectivity problems at the internet layer is a program called "traceroute." The traceroute program sends a series of "probe packets" using UDP to an IP address and awaits an ICMP reply. More specifically, IP datagrams carrying the UDP packets are sent with monotonically increasing values in the "time to live" (TTL) field, and the UDP port chosen is one most likely not to be in use. For each TTL value, the traceroute program sends a fixed number of packets (usually three), and reports back the IP addresses of the devices responding. This process continues until an ICMP port unreachable packet is received or some TTL threshold is reached (usually 30).

If a gateway receives an IP datagram and decrements the TTL to zero, then it returns an ICMP time exceeded packet. If the IP datagram eventually reaches the network device in question, an ICMP port unreachable packet will be returned. Combining the information from all the replies, the traceroute program can report on the whole route. See M. Rose, *supra*, at 66-67. A copy of the traceroute program is shown below.

- 3 -

*Copyright (c) 1988 Regents of the University of California.
 *All rights reserved.

*

5 *Redistribution and use in source and binary forms are permitted
 *provided that the above copyright notice and this paragraph are
 *duplicated in all such forms and that any documentation,
 *advertising materials, and other materials related to such
 *distribution and use acknowledge that the software was
 *developed by the University of California, Berkeley. The name
 10 *of the University may not be used to endorse or promote
 *products derived from this software without specific prior
 *written permission.
 *THIS SOFTWARE IS PROVIDED "AS IS" AND WITHOUT ANY EXPRESS OR
 *IMPLIED WARRANTIES, INCLUDING, WITHOUT LIMITATION, THE IMPLIED
 15 *WARRANTIES OF MERCHANTABILITY AND FITNESS FOR A PARTICULAR
 *PURPOSE.

*/

```
[7m--More--[m
[;H[2J
```

```
20 #include <stdio.h>
#include <errno.h>
#include <strings.h>
#include <sys/time.h>

25 #include <sys/param.h>
#include <sys/socket.h>
#include <sys/file.h>
#include <sys/ioctl.h>

30 #include <netinet/in_system.h>
#include <netinet/in.h>
#include <netinet/ip.h>
#include <netinet/ip_var.h>
35 #include <netinet/ip_icmp.h>
#include <netinet/udp.h>
#include <netdb.h>
#include <ctype.h>

40 #define MAXPACKET 65535 /* max ip packet size */
#ifndef MAXHOSTNAMELEN
#define MAXHOSTNAMELEN 64
[7m--More--[m
[;H[2J
45 #endif

#ifndef FD_SET
#define NFDBITS (8*sizeof(fd_set))
#define FD_SETSIZE NFDBITS
50 #define FD_SET(n, p) ((p)->fds_bits[(n)/NFDBITS] |= (1 << ((n)
% NFDBITS)))
#define FD_CLR(n, p) ((p)->fds_bits[(n)/NFDBITS] &= ~(1 <<
((n) % NFDBITS)))
#define FD_ISSET(n, p) ((p)->fds_bits[(n)/NFDBITS] & (1 << ((n) %
55 NFDBITS)))
```

- 4 -

```

#define FD_ZERO(p)      bzero((char *) (p), sizeof(* (p)))
#endif

#define Fprintf (void)fprintf
5 #define Sprintf (void)sprintf
#define Printf (void)printf

extern  int  errno;
extern  char *malloc();
10 extern  char *inet_ntoa();
extern  u_long inet_addr();

/*
  *format of a (udp) probe packet.
15 */
[7m--More--[m
[;H[2J
struct opacket {
20     struct ip ip;
     struct udphdr udp;
     u_char seq;           /* sequence number of this packet*/
     u_char ttl;         /* ttl packet left with*/
     struct timeval tv; /* time packet left*/
};
25
u_char packet[512];           /* last inbound (icmp) packet*/
struct opacket *outpacket; /* last output (udp) packet*/
char *inetname();

30 int s;                       /* receive (icmp) socket file
                               descriptor*/
int sndsock;                  /* send (udp) socket file
                               descriptor*/
35 struct timezone tz;         /* leftover*/

struct sockaddr whereto;     /* Who to try to reach*/
int datalen;                 /* How much data*/

char *source = 0;
40 char *hostname;
char hnamebuf[MAXHOSTNAMELEN];

[7m--More--[m
[;H[2J
45 int nprobes = 3;
int max_ttl = 30;
u_short ident;
u_short port = 32768+666;    /* start udp dest port#for probe
                               packets*/
50 int options;                /* socket options */
int verbose;
int waittime = 5;           /* time to wait for response
                               (in seconds)*/
55 int nflag;                /* print addresses numerically*/

```

- 5 -

```

char usage[] =
"Usage: traceroute [-dnrv] [-w wait] [-m max_ttl] [-p port#]
[-q nqueries] [-t tos] [-s src_addr] [-g gateway] host [data
size]\n";
5
main(argc, argv)
    char *argv[];
{
    struct sockaddr_in from;
10    char **av = argv;
    struct sockaddr_in *to = (struct sockaddr_in*)&whereto;
    int on = 1;
    struct protoent *pe;
    int ttl, probe, i;
15
    [7m--More--[m
    [;H[2J
    int seq = 0;
    int tos = 0;
20    struct hostent *hp;
    int lsrr = 0;
    u_long gw;
    u_char optlist[MAX_IPOPTLEN], *oix;
25
    oix = optlist;
    bzero(optlist, sizeof(optlist));

    argc--, av++;
    while (argc && *av[0] == '_') {
30        while (*++av[0])
            switch (*av[0]){
                case 'd':
                    options |= SO_DEBUG;
                    break;
35                case 'g':
                    argc--, av++;
                    if ((lsrr+1) >= ((MAX_IPOPTLEN-IPOPT_
MINOFF)
                    /sizeof(u_long)))
40 {
                        Fprintf(stderr, "No more than %/d
gateways\n",
                            ((MAX_IPOPTLEN_IPOPT_MINOFF)
                            /sizeof(u_[7m--
45 More--[m
    [;H[2J
    long))-1);

                                exit(1);
                                }
50                                if (lsrr == 0){
                                    *oix++ = IPOPT_LSRR;
                                    *oix++; /* Fill in total
length later*/
                                    *oix++ = IPOPT_MINOFF; /* Pointer to LSRR addresses*/
55                                }

```

- 6 -

```

lsrr++;
if (isdigit(*av[0])){
gw = inet_addr(*av);
if (gw) {
5   bcopy(&gw, oix, sizeof(u_long));
} else {
Fprintf(stderr, "Unknown host
%s\n", av[0]);
10  exit(1);
}
} else {
hp=gethostbyname(av[0]);
if (hp) {
15  bcopy(hp->h_addr, oix,
sizeof(u_long));
} else {

[7m--More--[m
[;H[2J

Fprintf(stderr, "Unknown host
20  %s\n", av[0]);
exit(1);
}
}
oix += sizeof(u_long);
goto nextarg;
case 'm':
argc--, av++;
max_ttl = atoi(av[0]);
if (max_ttl <= 1) {
30  Fprintf(stderr, "max ttl
must be >1\n");
exit(1);
}
goto nextarg;
35  case 'n':
nflag++;
break;
case 'p':
40  argc--, av++;
port = atoi(av[0]);
if (port < 1) {
Fprintf(stderr, "port
must be >0\n");
45  exit(1);
}
goto nextarg;
50  case 'q':
argc--, av++;
nprobes = atoi(av[0]);
if (nprobes < 1) {
Fprintf(stderr, "nprobes
55  must be >0\n");
exit(1);

```

- 7 -

```

    }
    goto nextarg;
case 'r':
    options |= SO_DONTROUTE;
    break;
5   case 's':
    /*
    * set the ip source address of
    the outbound
10  * probe (e.g., on a multi-homed
    host).
    */
    argc--, av++;
    source = av[0];
    goto nextarg;
15  case 't':
    argc--, av++;

[7m--More--[m
[;H[2J
20  tos = atoi(av[0]);
    if (tos < 0 || tos > 255) {
        fprintf(stderr, "tos
        must be 0 to 255\n");

    exit(1);
    }
    goto nextarg;
25  case 'v':
    verbose++;
    break;
30  case 'w':
    argc--, av++;
    waittime = atoi(av[0]);
    if (waittime <= 1) {
        fprintf(stderr, "wait
35  must be > 1 sec\n");
        exit(1);
    }
    goto nextarg;

    nextarg:
40  argc--, av++;
    }
[7m--More--[m
[;H[2J
45  if (argc < 1) {
    printf(usage);
    exit(1);
    }
    setlinebuf (stdout);

50  (void) bzero((char *)&whereto, sizeof(struct sockaddr));
    to->sin_family = AF_INET;
    to->sin_addr.s_addr=inet_addr(av[0]);
    if (to->sin_addr.s_addr != -1) {
        (void) strcpy(hnamebuf, av[0]);
55  hostname = hnamebuf;

```

- 8 -

```

    } else {
        hp = gethostbyname(av[0]);
        if (hp) {
            to->sin_family = hp->h_addrtype;
            bcopy(hp->h_addr, (caddr_t)&to->sin_
5             addr, hp-
             >h_length);
            hostname = hp->h_name;
        } else {
            Printf("%s: unknown host %s\n",
10             argv[0], av[0]);
            exit(1);
        }
    }
15 [7m--More--[m
    [;H[2J
        if(argc >= 2)
            datalen = atoi(av[1]);
        if (datalen < 0 || datalen >= MAXPACKET - sizeof
20         (struct opacket)) {
            Fprintf(stderr, "traceroute: packet size
            must be 0 <= s < %ld\n",
            MAXPACKET - sizeof(struct opacket));
            exit(1);
25         }
        datalen += sizeof(struct opacket);
        outpacket = (struct opacket
        *)malloc((unsigned)datalen);
        if (! outpacket) {
30             perror("traceroute: malloc");
            exit(1);
        }
        (void) bzero((char *)outpacket, datalen);
        outpacket->ip.ip_dst = to->sin_addr;
35         outpacket->ip.ip_tos = tos;

        ident = (getpid() & 0xffff | 0x8000);

        if ((pe = getprotobyname("icmp")) == NULL) {
40             Fprintf(stderr, "icmp: unknown protocol\n");
16 [7m--More--[m
            [;H[2J
                exit(10);
        }
45         if ((s = socket(AF_INET, SOCK_RAW, pe->p_proto)) < 0 {
            perror("traceroute: icmp socket");
            exit(5);
        }
    }
50     else
    {
        printf ("Opened recv side RAW socket, proto [ICMP]
            = %d\n",
            pe->p_proto);
    }
55     if (options & SO_DEBUG)

```

- 9 -

```

        (void) setsockopt(s, SOL_SOCKET, SO_DEBUG,
                          (char *)&on, sizeof(on));
    if (options & SO_DONTROUTE)
        (void) setsockopt(s, SOL_SOCKET,
5         SO_DONTROUTE,
                          (char *)&on, sizeof(on));

    if ((sndsock = socket(AF_INET, SOCK_RAW, IPPROTO_RAW))
10         < 0) {
        perror("traceroute: raw socket");
        exit(5);
    }
    [?lh=     }
    else
    [7m--More--[m
15    [;H[2J
        {
            printf ("Opened send side RAW socket,proto=IPPROTO_RAW
                \n");
        }
20
        if (lsrr > 0) {
            lsrr++;
            optlist[IPOPT_OLEN]=IPOPT_MINOFF-1+(lsrr*sizeof
25             (u_long));
            printf ("optlist[IPOPT_OLEN] = %d\n", optlist[IPOPT_OLEN]);

            bcopy((caddr_t)&to->sin_addr, oix,
30             sizeof(u_long));
            oix += sizeof(u_long);
            while ((oix - optlist)&3) oix++; /* Pad to an
                even
                boundry*/

            hex_display (optlist, (optlist[IPOPT_OLEN] + 4));
35
            if ((pe = getprotobyname("ip")) == NULL) {
                perror("traceroute: unknown protocol ip\n");

                exit(10);
40            }
            if ((setsockopt(sndsock, pe->p_proto,
                IP_OPTIONS, optlist,oix-optlist)) < 0){
    [7m--More--[m
    [;H[2J
45            perror("traceroute: lsrr options");
            exit(5);
        }
        else
50        {
            printf ("Set IP_OPTIONS (for loose routing), proto
                used=%d\n",
                pe->p_proto);
        }
    }
55

```

- 10 -

```

#ifndef SO_SNDBUF
    printf ("Using setsockopt SOL_SOCKET, SO_SNDBUF, \n");
5     if (setsockopt(sndsock, SOL_SOCKET, SO_SNDBUF,
        (char*)&datalen,
            sizeof(datalen)) < 0) {
            perror("traceroute: SO_SNDBUF");
            exit(6);
10    }
#endif SO_SNDBUF
#ifdef IP_HDRINCL
    printf ("IP_HDRINCL defined \n");
15    [7m--More--[m
    [;H[2J

    if (setsockopt(sndsock, IPPROTO_IP, IP_HDRINCL,
20    (char *)&on,
        sizeof(on)) < 0) {
            perror("traceroute: IP_HDRINCL");
            exit(6);
        }
#endif IP_HDRINCL
25    if (options & SO_DEBUG)
        (void) setsockopt(sndsock, SOL_SOCKET, SO_DEBUG,
            (char *)&on, sizeof(on));
    if (options & SO_DONTROUTE)
30        (void) setsockopt(sndsock, SOL_SOCKET,
            SO_DONTROUTE,
                (char *)&on, sizeof(on));
    if (source) {
        (void) bzero((char *)&from, sizeof(struct
35        sockaddr));
        from.sin_family = AF_INET;
        from.sin_addr.s_addr == inet_addr(source);
        if (from.sin_addr.s_addr == -1) {
            Printf("traceroute: unknown host
40            %s\n", source);
            exit(1);
        }
        outpacket->ip.ip_src = from.sin_addr;

    [7m--More--[m
45    [;H[2J
#endif IP_HDRINCL

    if (bind(sndsock, (struct sockaddr *)&from, sizeof
50    (from)) < 0) {
        perror ("traceroute: bind:");
            exit (1);
        }
#endif IP_HDRINCL
}
55

```

- 11 -

```

Fprintf(stderr, "traceroute to %s (%s)", hostname,
          inet_ntoa(to->sin_addr));
if(source)
    Fprintf(stderr, " from %s", source);
5   Fprintf(stderr, ", %d hops max, %d byte packets\n",
    max_ttl, datalen);
    (void) fflush(stderr);

10  for (ttl = 1; ttl <= max_ttl; ++ttl) {
        u_long lastaddr = 0;
        int got_there = 0;
        int unreachable = 0;

        Printf("%2d", ttl);
15  for (probe = 0; probe < nprobes; ++probe){
[7m--More--[m
[;H[2J
        int cc;
        struct timeval tv;
20  struct ip *ip;

        (void) gettimeofday(&tv, &tz);
        send_probe(++seq, ttl);
        while (cc = wait_for_reply(s,
25  &from)){
            if ((i = packet_ok(packet, cc,
                &from, seq)) {
                int dt = deltaT(&tv);
                if (from.sin_addr.s_
30  addr !
                    = lastaddr) {
                    print(packet,
                        cc, &from);
                    lastaddr =
                    from.sin_
35  addr.s_addr;
                }

                Printf(" %d ms",
                    dt);
40  switch(i - 1) {
                    case ICMP_UNREACH_
                        PORT:

                    ip = (struct
                    ip *) packet;
                    if (ip->ip_ttl
                    <= 1)
                    Printf("!");

                    ++got_there;
                    break;

                    #ifndef ARCHAIC

                    #endif ARCHAIC

50  ++got_there;
                    break;

                    [7m--More--[m
                    [;H[2J
                    case ICMP_UNREACH_NET:
                    ++unreachable;
55

```

- 12 -

```

                    Printf(" !N");
                    break;
                    case ICMP_UNREACH_HOST:
5                      ++unreachable;
                      Printf(" !H");
                      break;
                    case ICMP_UNREACH_
10                     PROTOCOL:
                      ++got there;
                      Printf(" !P");
                      break;
                    case ICMP_UNREACH_
15                     NEEDFRAG:
                      ++unreachable;
                      Printf(" !F");
                      break;
                    case ICMP_UNREACH_
20                     SRCFAIL:
                      ++unreachable;
                      Printf(" !S");
                      break;
                    }
                    break;
                }
25 [7m--More--[m
    [;H[2J
        }
        if (cc ==0)
            Printf("*");
30         (void) fflush(stdout);
    }
    putchar('\n');
    if (got_there || unreachable >= nprobes-1)
        exit(0);
35 }
}

wait_for_reply(sock, from)
    int sock;
40     struct sockaddr_in *from;
{
    fd_set fds;
    struct timeval wait;
    int cc = 0;
45     int fromlen = sizeof (*from);

    FD_ZERO(&fds);
    FD_SET(sock, &fds);
    wait.tv_sec = waittime; wait.tv_usec = 0;
50 [7m--More--[m
    [;H[2J

    if (select(sock+1, &fds, (fd_set *)0, (fd_set *)0,
55         &wait) > 0)
        cc--recvfrom(s, (char *)packet,

```

- 13 -

```

        sizeof(packet), 0,
        (struct sockaddr *)from,
        &fromlen);

5     return(cc);
    }

send_probe(seq, ttl)
{
10     struct opacket *op = outpacket;
        struct ip *ip = &op->ip;
        struct udphdr *up = &op->udp;
        int i;

15     ip->ip_off = 0;
        ip->ip_p = IPPROTO_UDP;
        ip->ip_len = datalen;
        ip->ip_ttl = ttl;

20     up->uh_sport = htons(ident);
        up->uh_dport = htons(port+seq);
        up->uh_ulen = htons((u_short)(datalen - sizeof(struct
        ip)));
    [7m--More--[m
25 [;H[2J     up->uh_sum = 0;

        op->seq = seq;
        op->ttl = ttl;
30     (void) gettimeofday(&op->tv, &tz);

        i = sendto(sndsock, (char *)outpacket, datalen, 0,
        &whereto,
        sizeof(struct sockaddr));
35     if (i < 0 || i != datalen) {
            if (i < 0)
                perror("sendto");
            Printf("traceroute: wrote %s %d chars, ret=%d\n", hostname,
                datalen, i);
40     (void) fflush(stdout);
        }
    }

deltaT(tp)
45     struct timeval *tp;
    {
        struct timeval tv;

        (void) gettimeofday(&tv, &tz);
50 [7m--More--[m
    [;H[2J     tvsub(&tv, tp);
        return (tv.tv_sec* 1000 + (tv.tv_usec + 500)/1000);
    }

55

```

- 14 -

```

/*
 * Convert an ICMP "type" field to a printable string.
 */
char*
5 pr-type(t)
    u_char t;
{
    static char *ttab[] = {
        "Echo Reply",      "ICMP 1",      "ICMP 2",      "Dest
10 Unreachable",
        "Source Quench",  "Redirect"    "ICMP 6",      "ICMP 7",
        "Echo",           "ICMP 9",    "ICMP 10"     "Time
        Exceeded",
        "Param Problem",  "Timestamp",  "Timestamp Reply", "Info
15 Request",
        "Info Reply"
    };

    if(t > 16)
20         return("OUT-OF-RANGE");

    return(ttab[t]);
    [7m--More--[m
    [;H[2J
25 }

packet_ok(buf, cc, from, seq)
    u_char *buf;
    int cc;
30     struct sockaddr_in *from;
    int seq;
}

    register struct icmp *icp;
    u_char type, code;
35     int hlen;
#ifdef ARCHAIC
    struct ip *ip;

    ip = (struct ip *) buf;
    hlen = ip->ip_hl << 2;
40     if (cc < hlen + ICMP_MINLEN) {
        if(verbose)
            Printf("packet too short (%d bytes)
            from %s\n", cc,
45             inet_ntoa(from->sin_addr));
        return (0);
    }
    cc -= hlen;
    [7m--More--[m
50 [;H[2J
    icp = (struct icmp *) (buf + hlen);
#else
    icp = (struct icmp *) buf;
#endif ARCHAIC
55     type = icp->icmp_type; code = icp->icmp_code;

```

- 15 -

```

if((type == ICMP_TIMXCEED && code == ICMP_TIMXCEED_
    INTRANS ||
    type == ICMP_UNREACH){
5     struct ip *hip;
        struct udphdr *up;

        hip = &icp->icmp_ip;
        hlen = hip->ip_hl << 2;
        up = (struct udphdr *)((u_char *)hip + hlen);
10     if (hlen + 12 <= cc && hip->ip_p ==
        IPPROTO_UDP &&
        up->uh_sport == htons(ident) &&
        up->uh_dport == htons(port+seq))
        return (type == ICMP_TIMXCEED? -1 :
15             code+1);
    }
#ifdef ARCHAIC
    if (verbose){
20         int i;
        u_long *lp = (u_long *)&icp->icmp_ip;

        [7m--More--[m
        [;H[2J
        Printf("\n%d bytes from %s to %s", cc,
25             inet_ntoa(from->sin_addr), inet_ntoa
            (ip->ip_dst));
        Printf(": icmp type %d (%s) code %d\n", type,
            pr_type(type),
            icp->icmp_code);
30         for (i = 4; i < cc; i += sizeof(long))
            Printf("%2d: x%8.8lx\n", i, *lp++);
    }
#endif ARCHAIC
    return(0);
35 }

print(buf, cc, from)
    u_char *buf;
    int cc;
40     struct sockaddr_in *from;
    {
        struct ip *ip;
        int hlen;

45         ip = (struct ip *) buf;
        hlen = ip->ip_hl << 2;
        cc -= hlen;

        [7m--More--[m
50     [;H[2J
        if (nflag)
            Printf(" %s", inet_ntoa(from->sin_addr));
        else
            Printf(" %s (%s)", inetname(from->sin_addr),
55             inet_ntoa(from->sin_addr));

```

- 16 -

```

        if (verbose)
            Printf ("%d bytes to %s", cc, inet_ntoa
                    (ip->ip_dst));
    }
5
    #ifndef notyet
    /*
    * Checksum routine for Internet Protocol family headers
    (C Version)
10
    */
    in_cksum(addr, len)
    u_short *addr;
    int len;
    {
15
        register int nleft.= len;
        register u_short *w = addr;
        register u_short answer;
        register int sum = 0;
20
        [7m--More--[m
        [;H[2J
        /*
        * Our algorithm is simple, using a 32 bit
25
        * accumulator (sum), we add sequential 16 bit words
        * to it, and at the end, fold back all the carry
        * bits from the top 16 bits into the lower 16 bits.
        */
        while (nleft > 1) {
30
            sum += *w++;
            nleft -= 2;
        }

        /* mop up an odd byte, if necessary */
35
        if (nleft == 1)
            sum += *(u_char *)w;

        /*
        * add back carry outs from top 16 bits to low 16 bits
40
        */
        sum = (sum >> 16) + (sum & 0xffff);        /* add hi 16 to
                                                    low 16*/
        sum += (sum >> 16);                        /* add carry */
        answer = ~sum;                             /* truncate to
45
                                                    16 bits*/

        return (answer);
    }

    [7m--More--[m
50
    [;H[2J
    #endif notyet

    /*
    *Subtract 2 timeval structs: out=out - in.
55
    * Out is assumed to be >= in.

```

- 17 -

```

*/
tvsub(out, in)
register struct timeval *out, *in;
{
5     if ((out->tv_usec -= in->tv_usec) < 0) {
        out->t_sec--;
        out->tv_usec += 1000000;
    }
    out->tv_sec -= in->tv_sec;
10 }

/*
 * Construct an Internet address representation.
 * If the nflag has been supplied, give
15 * numeric value, otherwise try for symbolic name.
 */
char

inetname(in)
20 [7m--More--[m
[H[2J
    struct in_addr in;
    {
        register char *cp;
        static char line[50];
        struct hostent *hp;
        static char domain[MAXHOSTNAMELEN + 1];
        static int first = 1;

30     if (first && !nflag){
        first = 0;
        if (gethostname(domain, MAXHOSTNAMELEN)
            == 0 &&
            (cp = index(domain, !)))
35         (void) strcpy(domain, cp + 1);
        else
            domain[0] = 0;
    }
    cp = 0;
40     if (!nflag && in.s_addr != INADDR_ANY){
        hp = gethostbyaddr((char *)&in, sizeof (in),
            AF_INET);
        if (hp){
            if ((cp = index(hp->h_name, '.')) &&
45         !strcmp(cp + 1, domain))
                *cp = 0;

[7m--More--[m
[H[2J
        cp = hp->h_name;
50     }
    }
    if (cp)
        (void) strcpy(line, cp);
55     else {

```

- 18 -

```

in.s_addr = ntohl(in.s_addr);
#define C(x) ((x) & 0xff)
                Sprintf(line, "%lu.%lu.%lu.%lu",
5                C(in.s_addr >> 24),
                C(in.s_addr >> 16), C(in.s_addr >> 8),
                C(in.s_addr));
                }
                return (line);
        }
10 hex_display (ptr, how_much)
    unsigned char * ptr;
    int how_much;
    {
15     int i;

        for (i=0; i < how_much; i++)
        {
                if((i % 8) == 0)
20 [7m--More--[m
                [;H[2J
                {
                printf ("\n");
                }
25     printf ("%4x", ptr[i]);
                }

        printf ("\n");
    }
30
----- end traceroute.c -----

```

Unfortunately, traceroute does not provide any information about which ports of the routers are on the path. In addition, not all devices on the network support IP options needed to implement traceroute.

An SNMP query to a router is another method for tracing a route, i.e., by determining the next-hop router on the current router IP routing table. Unfortunately, not all routers can be accessed by SNMP.

It would thus be desirable to provide a method of tracing a route from any source to any destination, regardless of whether one router is known, and regardless of whether each router on the path can be accessed using SNMP.

45

Summary of the Invention

- 19 -

The present invention is a method and apparatus for determining a communications path between a source node and a destination node on a network using IP. The method includes compiling a path list of IP addresses for next-hop routers on the path between the source IP address and the destination IP address.

In its broadest sense, the method includes the steps of: (a) sending a series of UDP probe packets out a socket of a first node to find successive next-hop routers on the path; (b) setting the socket of the first node to "loose route" the UDP probe packets through the source IP address; and (c) recording in the path list the next-hop router IP address returned following each one of the series of UDP probe packets. The UDP probe packets have a destination field set with the destination IP address. The time to live (TTL) field of the UDP probe packet is set with an initial value of one, and monotonically increased (i.e., incremented by one) to find each successive next-hop router until the destination is reached.

In a further embodiment, the method includes the step of alternatively sending an SNMP query to a router on the path in order to find the next-hop router on the path. Then, if the SNMP query fails, the method reverts to sending the next UDP probe packet. Thus, if a specific router on the path is discovered and can accept SNMP messages, we can then read its routing table to find out the next router on the way to the destination. The routing table also provides the port which leads to the next router.

In a still further embodiment, if both the UDP probe packet and/or SNMP query fail to provide the next-hop router IP address, then an unknown next-hop router IP address is selected and recorded in the path list. We later use a topology information database from a network management system to resolve this unknown router.

In a still further embodiment, the method includes sending a query to a topology information database to determine any unknown next-hop router IP addresses, as well as any

- 20 -

intra-router (i.e., layer-2 devices, such as hubs, bridges, etc.) on the path.

In this manner, we can determine a complete route from a source node to a destination node. Apparatus for implementing the method is further provided, including a station with a memory and processor for storing and running the traceroute program and/or a network management station for maintaining a management database and sending SNMP queries to various routers on the network which are SNMP compatible.

10

Brief Description of the Figures

FIG. 1 is a schematic diagram of a portion of a network in which there is a source node, a destination node, and a querying node.

15 FIG. 2 is a flowchart illustrating a mechanism by which the distance, in TTL units, is determined between the querying node and the source node.

FIG. 3 is a flowchart illustrating a mechanism for locating the next-hop router along the path from the source node to the destination node using TTL.

20 FIG. 4 is a flowchart illustrating the overall mechanism for locating the next router utilizing either an SNMP query or UDP probe packet.

FIG. 5 is a block diagram of a general purpose computer, for implementing the various path determination methods of this invention.

Detailed Description

FIG. 1 illustrates a general example, where there is a source node 11, a destination node 12, and a querying node 13. Additionally, there are routers r1 and r2 between the querying node 13 and the source node 11, and routers r3, r4 and r5 between the source node 11 and destination node 12. This representative network will be used to illustrate the method of the present invention.

35

In a first incremental TTL mechanism, illustrated in FIG. 2, we set a socket in query node 13, used for sending the

- 21 -

UDP probe packets, to "loose route" all packets through the source node 11. In this manner, we determine the number of routers between the querying node 13 and the source node 11, i.e., r1 and r2.

5 Once we know one router on the path, i.e., by the above incremental TTL mechanism, we can send an SNMP query to read its routing table to find out the next router on the path for the destination, along with the port which takes us to the next router. If this fails, we revert to the incremental TTL
10 mechanism to find the next-hop router. If both fail, we still continue, adding an unknown router to the path list. Our subsequent discovery of a network management system topology database, e.g., the Spectrum™ program sold by Cabletron Systems, Inc. of Rochester, New Hampshire, may enable us to determine all
15 unknown router nodes as well as identify any intra-router devices on the path.

More specifically, FIG. 2 illustrates the "how_far_is source(source, dest)" portion of our program. In step 21, we set the "loose-source routing" IP option on the socket through
20 which we are sending the UDP packets out. The source is the loose route we specify to the socket. Thus, all packets going through this socket will be routed through this loose route, i.e., source. See D. Comer, "Internetworking With TCP/IP, Vol. I, Principles, Protocols, And Architecture," Prentice Hall, 2nd
25 ed., pp. 103-104 (1991). In step 22, we initialize by setting ttl = 1, and in step 23 we send a UDP probe packet to the destination where TTL = ttl. In step 24 we wait for the TTL EXCEEDED ICMP message. If this message is received from the source, then we return(ttl). If not, in step 25 we increment
30 ttl by one and send another UDP probe packet.

If we are unable to contact a router with an SNMP query, or if we choose to continue using the TTL mechanism, we then utilize the "find_next_hop_using_ttl(source, dest, ttl)"
portion of our program illustrated in FIG. 3. Again, in step 51
35 we send a UDP probe packet to the destination with TTL = ttl and in step 52 we wait for one of the following ICMP responses: TTL EXCEEDED, or PORT_UNREACHABLE. If the message TTL_EXCEEDED is

- 22 -

received, this message has come from one of the intermediate hosts and in step 53 we set IP address = sender of the ICMP message and record its IP address in our path list. If in step 54 no response is received within a designated time period, in
5 step 55 we increment the retry_count and send another UDP probe packet (return to step 51). If (in step 54) we have reached the maximum period, i.e., MAX_RETRY, then we set the IP address to an unknown IP address (step 56) and enter the same in the path list.

10 If a PORT_UNREACHABLE message is received (step 57), this message can only come from the destination and therefore we enter the IP address of the destination in our path list and we are finished.

FIG. 4 illustrates generally a preferred method in
15 which we first try an SNMP search 31 (assuming we have a known router), and if it is successful (step 32), we continue to increment TTL (step 34) and then return to conduct an SNMP search (step 31) on the next-hop router. If the SNMP search is not successful, we send (step 33) a UDP probe packet to
20 determine the next-hop router. If this is successful (step 35), we again increment TTL (step 34) and then conduct an SNMP search on the next-hop router. If the UDP probe packet search is not successful, we add (step 36) an unknown router address to our path list and then increment TTL (step 34). Once we have
25 reached the destination, we can then query our management database (i.e., Spectrum™) (step 37) to determine all the intra-router devices, i.e. layer-2 devices including hubs, bridges, etc., between each pair of routers discovered previously. We can also use the management database to try to
30 resolve the unknown router nodes in the path list. Essentially, we use management database's knowledge of how the various device models are connected to each other. For example, Spectrum™ acquires this knowledge during an "autodiscovery" process of all the devices on the network. The Spectrum™ network management
35 platform is described in U.S. Patent No. 5,261,044 and in copending and commonly owned U.S. Serial No. 07/797,121 filed November 22,

- 23 -

1991 by R. Dev et al., which are hereby incorporated by reference in their entirety. Spectrum™ implements the Autodiscovery process described in copending and commonly owned U.S. Serial No. 08/115,232 filed September 1, 1993 by T. Orr et
5 al., which is also incorporated by reference in its entirety. The present invention is not limited to use of the Spectrum™ database, but contemplates the use of any such topology database which defines the relative location of devices on the network.

The program may be implemented in a general purpose
10 computer 41 such as shown in FIG. 5. As can be seen, the general purpose computer includes a computer processing unit (CPU) 42, memory 43, a processing bus 44 by which the CPU can access the memory, and access to a network 45.

The following code can be used to illustrate the
15 method of this invention:

```
discover_ip_path (source, dest)
(
//Variables used:
20 //
// source    : user specified source IP address
// dest      : user specified destination IP address
// curr_ttl  : this will be used to find the next
                router when the TTL mechanism is
25                used.
// path_list: list used for storing the discovered
                path

    sending-socket = open a RAW socket to send out
30    the UDP probe packets.

    if (source is same as the station running this
        application)
    (
35        curr_ttl = 0
    )
    else
```

- 24 -

```
(
    Set the sending-socket to loose-route UDP probe
    packets through the source. This will be used in
    "how_far_is_source" and "trace_next_hop_using_
5    ttl" calls below.

    curr_ttl = how_far_is_source (source, dest)

)

10
    curr_node = source
    path_list = empty list.
    while (curr_node != dest)
    (
15        next_hop = NULL

        if (curr_node is a router and Spectrum has a SNMP
        model for it)
        (
20            next_hop = trace_next_hop_using_snmp (dest.
            curr_node)
        )
        if (! next_hop) // SNMP method failed. Let's try
        TTL method.
25        (
            next_hop = trace_next_hop_using_ttl (dest, curr_
            ttl);
        )
        if (! next_hop) // Even the TTL method failed.
30        (
            path_list->add (unknown_router);
        )
        else
        (
35            path_list->add (next_hop)
        )
        curr_ttl++ // increment curr_ttl
```

- 25 -

```
curr_node = next_hop
)
phase_2_discovery (path_list);
)
5 how_far_is_source (source, dest)
(
    Use incremental TTL value program to find out how many hops
    away is the source from the station
    running this program.
10 Note: that all UDP packets used herein originate from the
    station running this program and are destined for dest.
    The loose-routing option set above will force these packets
    to take following path:
    source ----->dest
15
    application running this program
)
trace_next_hop_using_ttl (dest, curr_ttl)
(
20 Sending-socket is already set to loose-route the
    packets through source.
    send a UDP probe packet to dest with TTL value
    equal to (curr_ttl+1) and wait for the ICMP TTL_
    EXPIRED message.
25 This message will come from the next router we
    are looking for.
)
trace_next_hop_using_snmp (dest, curr_node)
(
30 This method uses SNMP queries to find out the next node in
    the path. IP routing table is read from the curr_node to
    find out the next hop for the given destination.

    If the dest address is a.b.d.c., we try to read the next
35 hop values for the following addresses (in this order)
    until one succeeds:
        a.b.c.d
```

a.b.c.0
 a.b.0.0
 a.0.0.0

If the next hop value is successfully found, we also return
 5 the corresponding port information (i.e. port of curr_node
 which connects to the next-hop).

The following is an example of an SNMP routing table:

	Destination	Next-Hop	Out_port
10	134.141.1.0	via 134.141.150.251	Ethernet1
	134.141.7.0	via 134.141.150.251	Ethernet1
	134.141.6.0	via 134.141.150.251	Ethernet1
	134.141.159.0	via 134.141.155.254	Serial0
15	134.141.153.0	directly connected	Ethernet0
	134.141.152.0	directly connected	Ethernet1

If a search of the IP routing table fails to find the
 next hop, it returns an invalid IP address. This
 20 causes the "discover_ip_path ()" method to use the
 "find_next_hop_using_TTL ()" method to find the next
 hop.

Example

The following example illustrates a method of the
 25 invention in accordance with the representative network shown in
 FIG. 1.

In this example, arrows show the path the UDP
 probe packets are going to take.

querying: the node running this program
 30 source: given source IP address
 dest: given dest IP address

r1, r2: routers between querying node and source
 r3, r4, r5: routers between source and dest

35

The socket used for sending the UDP probe packets from the
 querying node is set to loose-route all packets through source.

- 27 -

Also, all the UDP probe packets are sent to dest on an unused destination port number, so that if the probe reaches the dest, the dest will send us back a PORT_UNREACHABLE ICMP message.

5 how_far_is_source (source, dest)

For ttl=1, r1 will send the TTL_EXCEEDED ICMP message,

10 for ttl=2, r2 will send the TTL_EXCEEDED ICMP message

for ttl=3, source will send the TTL_EXCEEDED ICMP message

and this method will return 3.

15 subsequent discovery

The subsequent discovery will depend on whether we have SNMP models for source, r3, r4 and r5 etc. in our Spectrum™ database, e.g.,

20 r3 will be discovered by reading the routing table from the source or using the TTL mechanism with TTL=4

25 r4 will be discovered by reading the routing table from r3 or using the TTL mechanism with TTL=5

Similarly r5 will be discovered by reading the routing table from r4 or using the TTL mechanism with TTL=6

30 Finally, we will know that dest is directly connected to r5, either by reading a direct routing entry for dest from r5, or using TTL mechanism (TTL=7) we will receive a PORT_UNREACHABLE ICMP message from the dest.

35 Having thus described a particular embodiment of the invention, various alterations, modifications and

improvements will readily occur to those skilled in the art. Accordingly, the foregoing description is by way of example only, and not intended to be limiting. The invention is limited only as defined in the
5 following claims and the equivalents thereto.

- 29 -

CLAIMS

1. A method for determining a path list of IP addresses for next-hop routers on a path between a source IP address and a destination IP address, the method comprising the
5 steps of:

10 sending a series of UDP probe packets out a socket of a querying node to find successive next-hop routers on the path, the UDP probe packets having a destination field set with the destination IP address and a TTL
field set with an initial value of one and being
monotonically incremented to find each successive
next-hop router until the destination is reached;

15 setting the socket of the querying node to loose route the UDP probe packets through the source IP address; and

recording in the path list the next-hop router IP address returned following each one of the series of
UDP probe packets.

20 2. The method of claim 1, further including sending an SNMP query to a router on the path in order to find the next-hop router on the path, and if the SNMP query fails, reverting to sending the next UDP probe packet.

25 3. The method of claim 2, further including if the UDP probe packet fails to provide the next-hop router IP address, selecting an unknown next-hop router IP address to record in the path list.

30 4. The method of claim 3, further including sending a query to a topology information database to determine any unknown next-hop router IP addresses and any intra-router devices on the path.

35 5. A method for determining a communications path between a source and a destination on a network using IP, comprising the steps of:

- 30 -

- 5
- a. determining a current router on the communications path; and
 - b. determining a next router on the communications path from the current router on the communications path, including the steps of:
 - b(i) determining the next router via an SNMP query of the current router;
 - b(ii) determining the next router by sending a UDP probe packet when an SNMP query fails to indicate the next router.
- 10
6. The method of claim 5, further including the step of:
- c. iterating step b. until the the next router is determined to be the destination.
- 15
7. The method of claim 5, wherein step a. further including the steps of:
- a(i) setting a TTL value to 1;
 - a(ii) sending a UDP probe packet with the TTL value to the source;
 - a(iii) awaiting receipt of a TTL_EXCEEDED ICMP message from a current
- 20
- a(iv) determining the IP address of the current router; and
 - a(v) incrementing TTL, and repeating steps a(ii), a(iii), and a (iv) until the TTL_EXCEEDED ICMP message is received from the
- 25
- 30
- source.
8. The method of claim 5, wherein step b(i) includes
- 35 the steps of:
- b(i)(1) querying the current router for a routing table; and

- 31 -

b(i)(2) determining the next router from the routing table.

9. The method of claim 5, wherein step b(ii) further includes the steps of:

b(ii)(1) setting a TTL value to one plus the number of routers, including the source as a router, between a querying node and the current router;

10 b(ii)(2) sending a UDP probe packet with the TTL value to the destination through the source, with loose source routing specified;

15 b(ii)(3) awaiting receipt of a TTL_EXCEEDED ICMP message;

b(ii)(4) determining the IP address of the next router; and

20 b(ii)(5) incrementing TTL, and repeating steps b(ii)(2)-(4) until the TTL_EXCEEDED ICMP message is received from the destination.

10. The method of claim 5, wherein step b. includes the step of adding the next router to a path list.

25

11. An apparatus for determining a communications path between a source and a destination on a network using IP, comprising:

30 means for determining a router on the communications path;

means for determining a next router on the communications path from a current router on the communications path;

35 wherein the means for determining a next router includes:

means for determining the next router via an SNMP query; and

- 32 -

means for determining the next router by sending a UDP probe packet when an SNMP query fails to indicate the next router.

5 12. The apparatus of claim 11, further including:
 means for iterating the means for determining a
next router until the the next router is determined to
be the destination.

10 13. An electronic storage media, containing data
representing a computer program, wherein the electronic storage
media, when connected with a general purpose computer,
comprises:

 means for determining a current router on a
15 communications path from a source to a destination;
 means for determining a next router on the
communications path from a current router on the communications
path, including:

 means for determining the next router via an
20 SNMP query;

 means for determining the next router by
sending a UDP probe packet when an SNMP query fails to indicate
the next router;

 means for iterating the means for determining
25 the next router until the next router is determined to be the
destination.

1 / 3

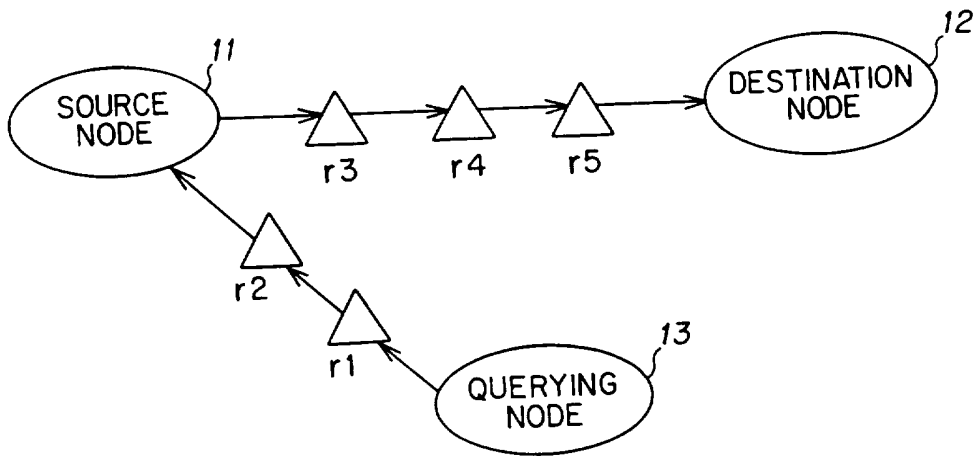

FIG. 1

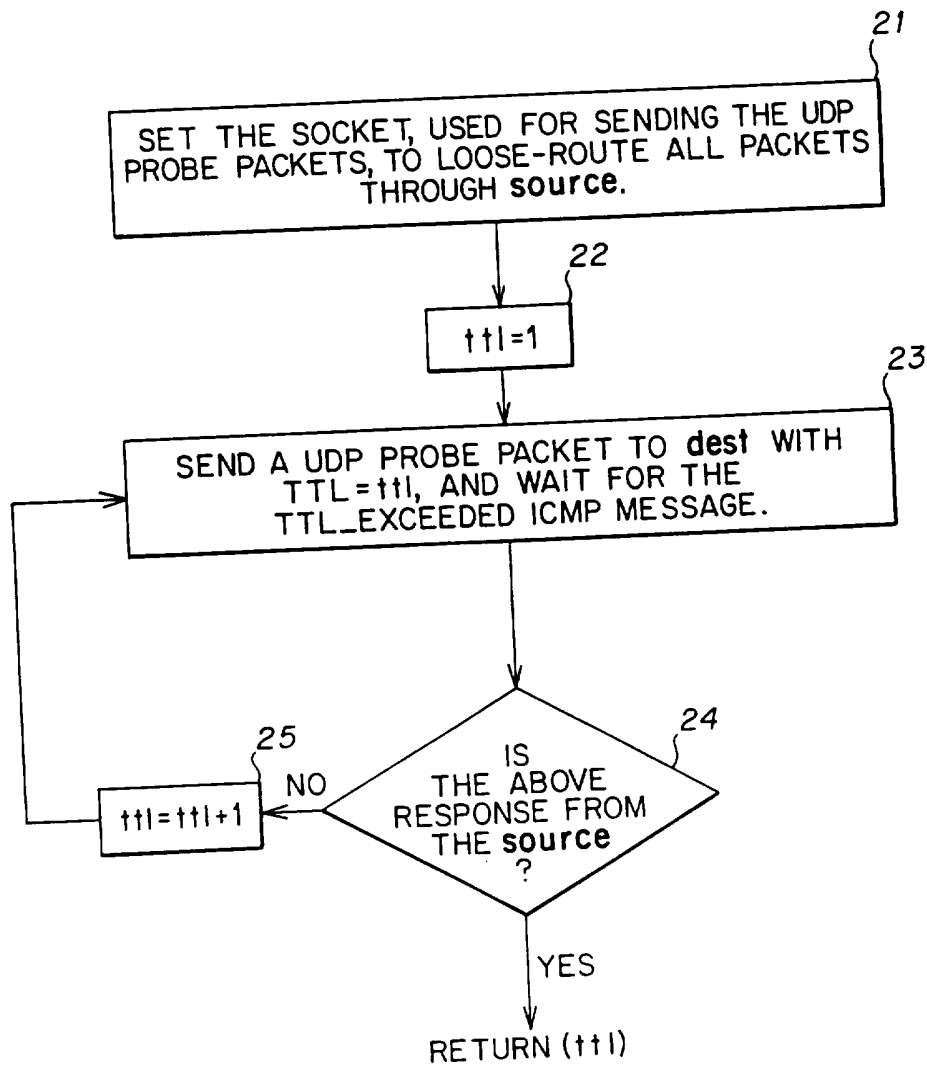

FIG. 2

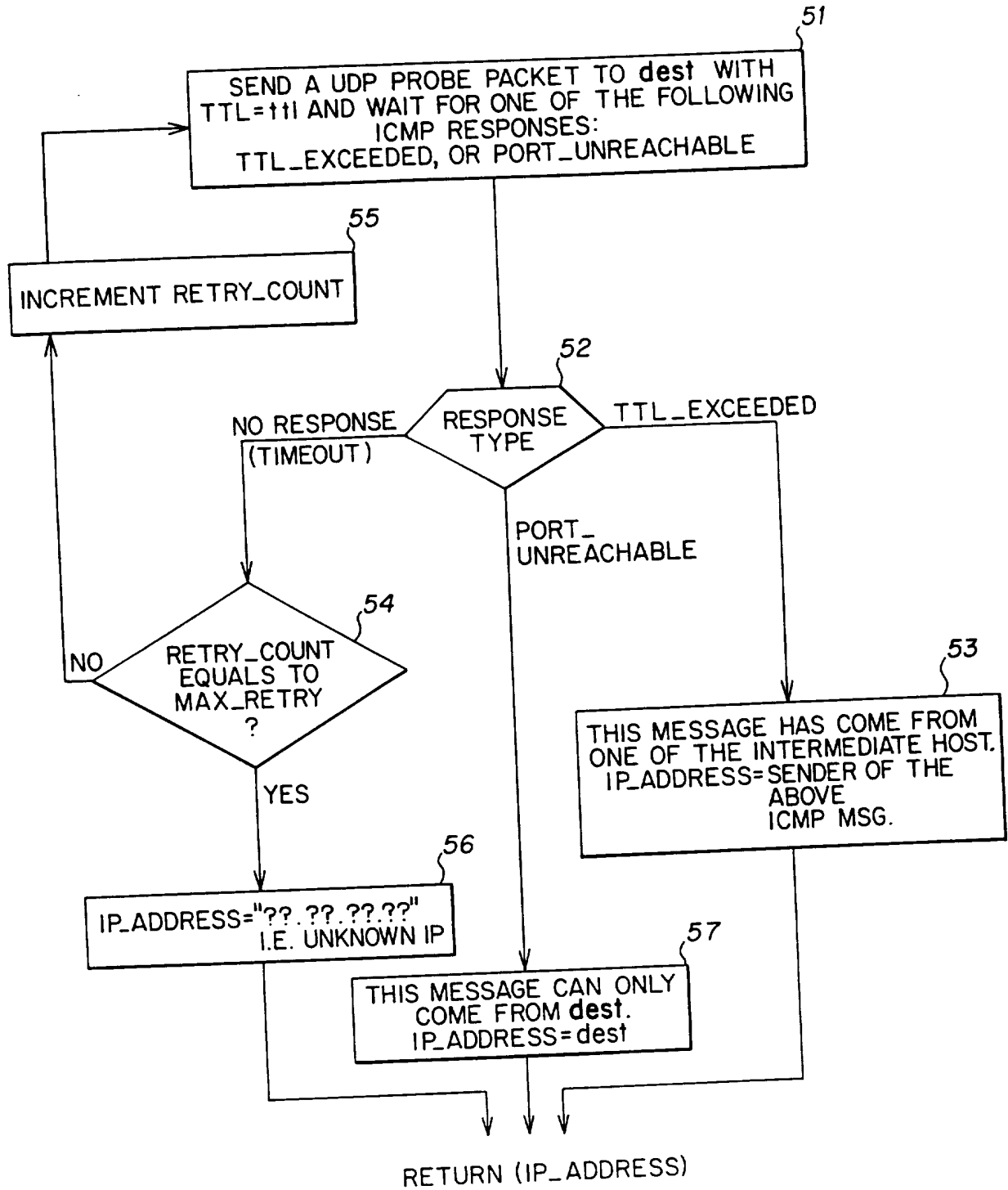

FIG. 3

3/3

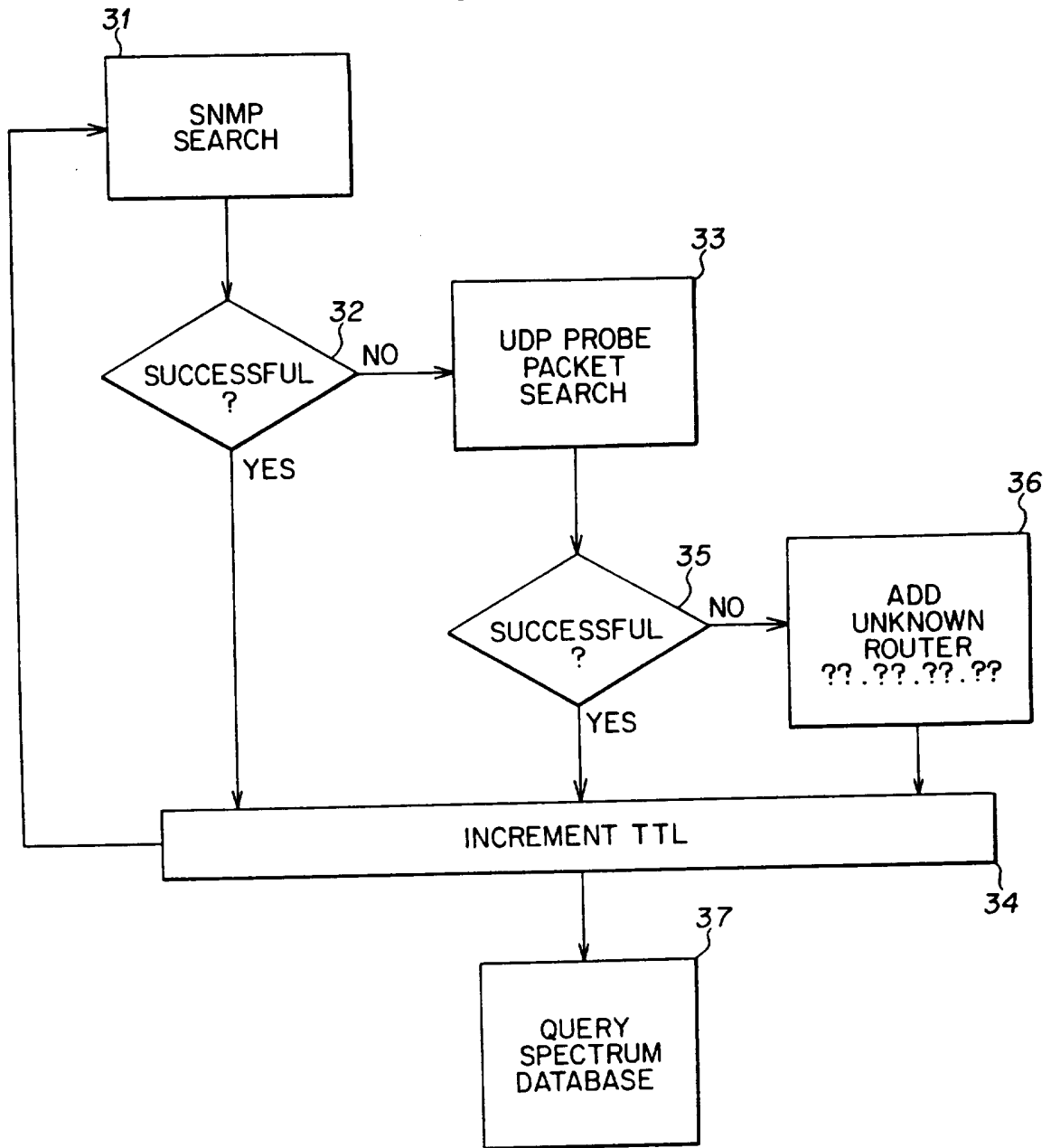

FIG. 4

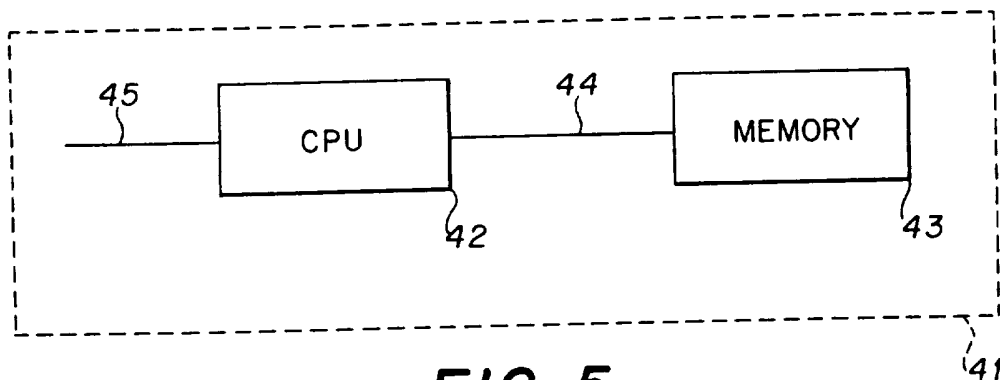

FIG. 5