

June 2, 1953

B. W. BYFORD

2,640,595

AUTOMOBILE SEAT ARTICLE HOLDER

Filed July 1, 1949

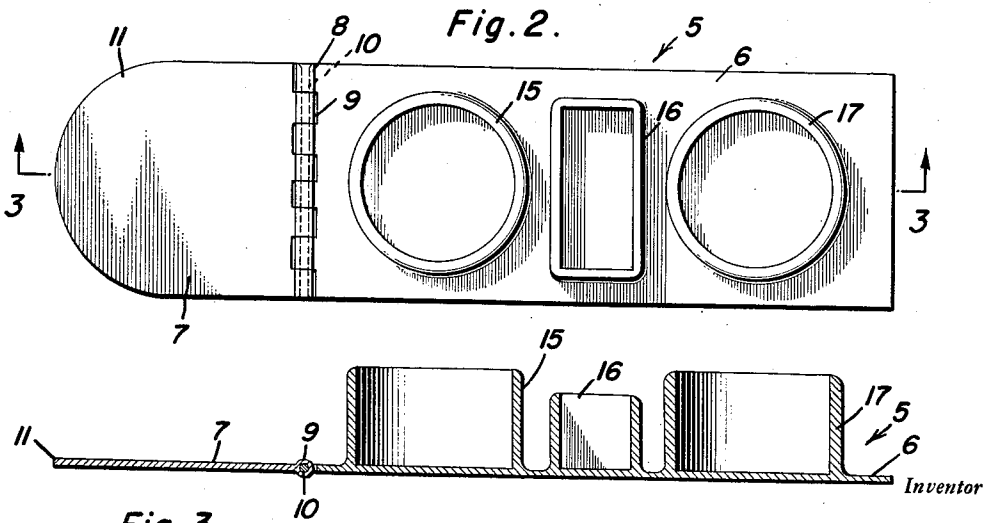
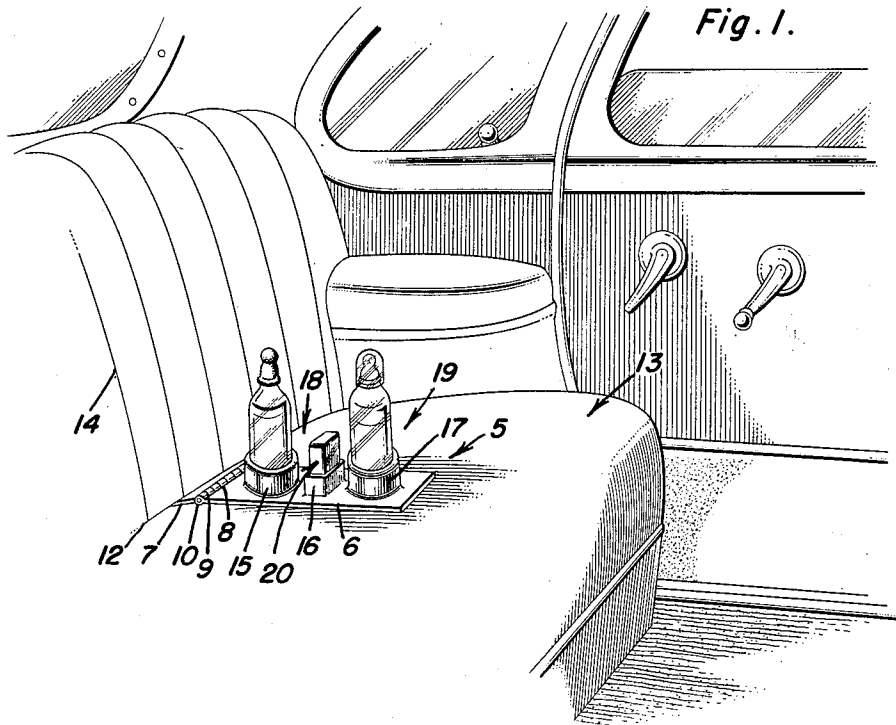
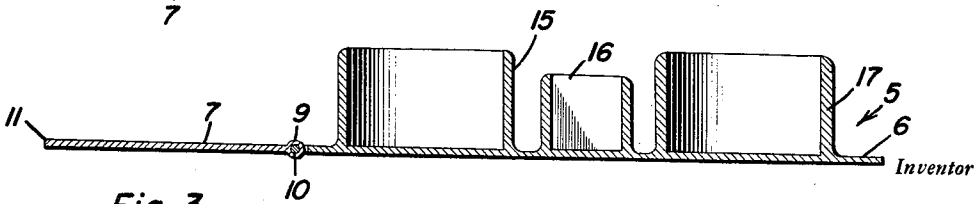

Fig. 3.



Burnard W. Byford

By *Clarence A. O'Brien*
and Harvey B. Jacobson
Attorneys

UNITED STATES PATENT OFFICE

2,640,595

AUTOMOBILE SEAT ARTICLE HOLDER

Burnard W. Byford, McGregor, Tex.

Application July 1, 1949, Serial No. 102,648

1 Claim. (Cl. 211-74)

1

The present invention relates to automotive accessories and appliances, generally speaking, and has more particular reference to a seat attachment having facilities for conveniently supporting and holding miscellaneous articles, for instances, a nursing bottle, bottle containing a soft drink, a glass full of water, a package of cigarettes, and so on.

It is a matter of common knowledge to those who ride in so-called pleasure cars that it is often unhandy for the occupants, especially if the car be at all crowded, to conveniently manage and hold liquid-filled containers, such as a cup full of coffee, glass full of water, beverage bottles, nursing bottles, and so on. True, I am aware that curb service attendants supply detachable door trays for use at road side restaurants; that it is not uncommon for certain types of automobiles and cars to have retractable and projectable shelves which are a permanent part of the car. Nevertheless, there is a definite need, I believe, for a suitable holder such as may be laid or placed upon the seat adjacent to the user, the same being of such construction that it will satisfactorily support articles of the kind above specified.

As is evident from the preceding description, my objective is to provide, for those who have need for it, a simple, practical and economical seat attachment which may be readily and conveniently brought into play in a manner to hold liquid containers and which, when not in use, may be readily detached, folded into compact form and stored away in an instrument panel glove compartment.

More explicitly, the invention has to do with a sheet material mat-like base which may be laid flat upon the crown of the usual seat cushion and which includes a retaining flap, said flap being hingedly mounted and being adapted to be wedged between the cushion and usual back rest of the seat structure in a manner to frictionally and satisfactorily locate and retain the mat in order that the receptacles or holders thereon may be conveniently and reliably used.

Other objects and advantages will become more readily apparent from the following description and the accompanying illustrative drawings.

In the accompanying sheet of drawings, wherein like numerals are employed to designate like parts throughout the views:

Figure 1 is a fragmentary perspective view showing a portion of the tonneau of a pleasure car or automobile, showing the seat structure and

2

showing my seat attachment and the manner in which same is installed and used.

Figure 2 is an enlarged top plan view of said attachment.

Figure 3 is a longitudinal section on the line 3-3 of Figure 2, looking in the direction of the arrows.

Referring now to the drawings by distinguishing reference numerals and to Figure 2, the attachment is denoted, as a general structure, by the numeral 5. It is characterized by a rectangular body or base portion 6 having a flap 7, the parts 6 and 7 having coacting knuckles 8 and 9 to accommodate a hinge pin 10. The left-hand or free end portion of the flap, the end 11 in Figure 2, is rounded to permit said flap to be wedged into the existing space 12 between the seat cushion 13 and back rest 14 of the seat construction as shown in Figure 1. The base 6 may also be known, I believe, as a mat which is of such form that it may conform to and rest firmly and reliably upon the convexed surface of the cushion 13. Thus, and so far, we have a rectangular mat or base with a flap hingedly connected to one end, said flap being adapted to wedge itself between the back rest and cushion, as shown in the drawings, to satisfactorily hold the base in a usable position. Formed integral with the top of the mat are a plurality of receptacles or holders, these denoted by the numerals 15, 16 and 17, respectively. Holders 15 and 17 are of cup-like form and constitute receivers for liquid containers. The "containers" referred to may be of various kinds and types, as, for example, cups, glasses, goblets, and so on. Primarily, I have had in mind making the holders to accommodate two, more or less, nursing bottles denoted by the numerals 18 and 19. Of course, these receptacles 15 and 17 may be of various shapes, sizes and proportions to accommodate all sorts of containers. It is desirable, I feel, to make the intermediate receptacle 16 of rectangular form and to make it of a size to function as a holder for a package of cigarettes, as denoted at 20 in Figure 1.

Obviously, the parts which go to make up the attachment may be made of synthetic resins or so-called commercial plastics of various grades and colors or, if found more suitable, the parts may preferably be sheet metal. It is believed that the material should be sufficiently stiff to be shaped and self-sustaining in character. Also, the overall length of the device when the flap is folded against the mat or base should be such that it may be stored in an out-of-the-way posi-

3

tion when not in use, in the usual glove compartment.

In view of the foregoing description taken in conjunction with the accompanying drawings, it is believed that a clear understanding of the device will be quite apparent to those skilled in this art. A more detailed description is accordingly deemed unnecessary.

It is to be understood, however, that even though there is herein shown and described a preferred embodiment of the invention, the same is susceptible to certain changes fully comprehended by the spirit of the invention as herein described and within the scope of the appended claim.

Having described the invention, what is claimed as new is:

An automobile seat attachment of a type which may be folded into compact form and carried, when not in use, in the glove compartment and which, when in use, serves to permit nursing bottles and the like to be held in an erect and accessible position and supported on a seat cushion comprising an elongated substantially flat and rigid mat adapted, when in use, to rest upon the surface of the stated seat cushion, a flap, smaller than said mat and disposed in a plane with and hingedly connected to an end portion of said mat, said flap being adapted to be tucked removably and frictionally between the seat cushion and

4

lower edge of the coacting backrest in a manner to temporarily anchor said mat in useful position, said mat being made from moldable material, and a plurality of socket-type article-receiving and holding members molded on the normal top side of said mat, said flap being flat and being foldable against the bottom of the mat when the attachment is not in use, and said receivers being of cup-like form and adapted to telescopically receive bottles and the like, and the rear non-hinged edge portion of said flap being rounded to facilitate piloting and feeding the flap into the stated anchoring position.

BURNARD W. BYFORD.

15

References Cited in the file of this patent

UNITED STATES PATENTS

Number	Name	Date
1,492,651	Rowley -----	May 6, 1924
1,705,867	Korkames -----	Mar. 19, 1929
1,742,822	Olson -----	Jan. 7, 1930
1,962,556	Eberhardt, Jr. -----	June 12, 1934
2,016,097	Parson -----	Oct. 1, 1935
2,510,244	Moltrup -----	June 6, 1950
2,572,526	Schuessler -----	Oct. 23, 1951

FOREIGN PATENTS

Number	Country	Date
320,987	Great Britain -----	Oct. 31, 1929
370,129	Great Britain -----	Apr. 7, 1932