

(12) STANDARD PATENT
(19) AUSTRALIAN PATENT OFFICE

(11) Application No. **AU 2006251938 B2**

(54) Title
Stentless support structure

(51) International Patent Classification(s)
A61F 2/06 (2006.01) **A61F 2/24** (2006.01)

(21) Application No: **2006251938** (22) Date of Filing: **2006.05.30**

(87) WIPO No: **WO06/128193**

(30) Priority Data

(31) Number	(32) Date	(33) Country
60/709,595	2005.08.18	US
60/685,349	2005.05.27	US

(43) Publication Date: **2006.11.30**

(44) Accepted Journal Date: **2011.09.29**

(71) Applicant(s)
Heart Leaflet Technologies, Inc.

(72) Inventor(s)
Thill, Gary A.;Wilson, Robert Foster;Banick, Christopher M.;Gainor, John

(74) Agent / Attorney
Phillips Ormonde Fitzpatrick, 367 Collins Street, Melbourne, VIC, 3000

(56) Related Art
US6592614 A (Lenker et al.) 15 July 2003
US2004/0220664 A1 (Chobotov) 4 November 2004

(12) INTERNATIONAL APPLICATION PUBLISHED UNDER THE PATENT COOPERATION TREATY (PCT)

(19) World Intellectual Property Organization
International Bureau



(43) International Publication Date
30 November 2006 (30.11.2006)

PCT

(10) International Publication Number
WO 2006/128193 A3

- (51) **International Patent Classification:**
A61F 2/06 (2006.01) A61F 2/24 (2006.01)
- (21) **International Application Number:**
PCT/US2006/021021
- (22) **International Filing Date:** 30 May 2006 (30.05.2006)
- (25) **Filing Language:** English
- (26) **Publication Language:** English
- (30) **Priority Data:**
60/685,349 27 May 2005 (27.05.2005) US
60/709,595 18 August 2005 (18.08.2005) US
- (71) **Applicant (for all designated States except US): HEART LEAFLET TECHNOLOGIES, INC.** [US/US]; 7351 Kirkwood Lane North Suite 104, Maple Grove, MN 55369 (US).
- (72) **Inventors; and**
- (75) **Inventors/Applicants (for US only): THILL, Gary, A.** [US/US]; 3741 Centerville Road, Vadnais Heights, MN 55127 (US). **WILSON, Robert, Foster** [US/US]; 3107 West Owasso Boulevard, Roseville, MN 55113 (US). **GAINOR, John** [US/US]; 1273 Bibeau Road, White Bear Township, MN 55110 (US). **BANICK, Christopher,**
- (74) **Agent: INSKEEP, James, W.;** INSKEEP INTELLECTUAL PROPERTY GROUP, INC., 2281 W. 190th Street, Ste. 200, Torrance, CA 90504 (US).
- (81) **Designated States (unless otherwise indicated, for every kind of national protection available):** AE, AG, AL, AM, AT, AU, AZ, BA, BB, BG, BR, BW, BY, BZ, CA, CH, CN, CO, CR, CU, CZ, DE, DK, DM, DZ, EC, EE, EG, ES, FI, GB, GD, GE, GH, GM, HR, HU, ID, IL, IN, IS, JP, KE, KG, KM, KN, KP, KR, KZ, LC, LK, LR, LS, LT, LU, LV, LY, MA, MD, MG, MK, MN, MW, MX, MZ, NA, NG, NI, NO, NZ, OM, PG, PH, PL, PT, RO, RU, SC, SD, SE, SG, SK, SL, SM, SY, TJ, TM, TN, TR, TT, TZ, UA, UG, US, UZ, VC, VN, YU, ZA, ZM, ZW.
- (84) **Designated States (unless otherwise indicated, for every kind of regional protection available):** ARIPO (BW, GH, GM, KE, LS, MW, MZ, NA, SD, SL, SZ, TZ, UG, ZM, ZW), Eurasian (AM, AZ, BY, KG, KZ, MD, RU, TJ, TM), European (AT, BE, BG, CH, CY, CZ, DE, DK, EE, ES, FI, FR, GB, GR, HU, IE, IS, IT, LT, LU, LV, MC, NL, PL, PT, RO, SE, SI, SK, TR), OAPI (BF, BJ, CF, CG, CI, CM, GA, GN, GQ, GW, ML, MR, NE, SN, TD, TG).

[Continued on next page]

(54) **Title:** STENTLESS SUPPORT STRUCTURE

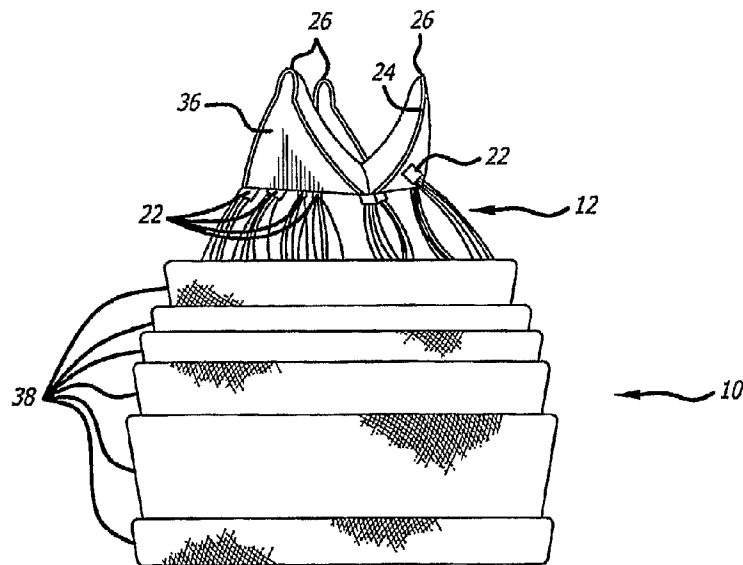

(57) **Abstract:** A stentless support structure capable of being at least partly assembled in situ. The support structure comprises a braided tube that is very flexible and, when elongated, becomes very long and very small in diameter, thereby being capable of placement within a small diameter catheter. The support structure is preferably constructed of one or more thin strands of a super-elastic or shape memory material such as Nitinol. When released from the catheter, the support structure folds itself into a longitudinally compact configuration. The support structure thus gains significant strength as the number of folds increase. This radial strength obviates the need for a support stent. The support structure may include attachment points for a prosthetic valve.

WO 2006/128193 A3

WO 2006/128193 A3



Published:

— *with international search report*

(88) Date of publication of the international search report:

22 November 2007

For two-letter codes and other abbreviations, refer to the "Guidance Notes on Codes and Abbreviations" appearing at the beginning of each regular issue of the PCT Gazette.

STENTLESS SUPPORT STRUCTURE

CROSS-REFERENCE TO RELATED DOCUMENTS

[0001] This application is related to and claims priority benefit of U.S. Provisional Patent Application Serial No. 60/685,349, filed May 27, 2005, entitled *Stentless Support Structure*, by Wilson et al. and U.S. Provisional Patent Application Serial No. 60/709,595, filed August 18, 2005, entitled *Stentless Support Structure* by Wilson et al. These applications are also hereby incorporated by reference herein. This application also incorporates by reference U.S. Patent Application Serial No. _____ entitled *Intravascular Cuff* filed by Applicant on even date herewith and U.S. Provisional Patent Application Serial No. 60/685,433, filed May 27, 2005, entitled *Intravascular Cuff*.

BACKGROUND OF THE INVENTION

[0002] There has been a significant movement toward developing and performing cardiovascular surgeries using a percutaneous approach. Through the use of one or more catheters that are introduced through, for example, the femoral artery, tools and devices can be delivered to a desired area in the cardiovascular system to perform many number of complicated procedures that normally otherwise require an invasive surgical procedure. Such approaches greatly reduce the trauma endured by the patient and can significantly reduce recovery periods. The percutaneous approach is particularly attractive as an alternative to performing open-heart surgery.

[0003] Valve replacement surgery provides one example of an area where percutaneous solutions are being developed. A number of diseases result in a thickening, and subsequent immobility or reduced mobility, of heart valve leaflets. Such immobility also may lead to a narrowing, or stenosis, of the passageway through the valve. The increased resistance to blood flow that a stenosed valve presents can eventually lead to heart failure and ultimately death.

[0004] Treating valve stenosis or regurgitation has heretofore involved complete removal of the existing native valve through an open-heart procedure followed by the implantation of a prosthetic valve. Naturally, this is a heavily invasive procedure and inflicts great trauma on the body leading usually to great discomfort and considerable recovery time. It is also a sophisticated procedure that requires great expertise and talent to perform.

[0005] Historically, such valve replacement surgery has been performed using traditional open-heart surgery where the chest is opened, the heart stopped, the patient placed on cardiopulmonary bypass, the native valve excised and the replacement valve attached. A proposed percutaneous valve replacement alternative method on the other hand, is disclosed in U.S. Pat. No. 6,168,614 (the entire contents of which are hereby incorporated by reference) issued to Andersen et al. In this patent, the prosthetic valve is mounted on a stent that is collapsed to a size that fits within a catheter. The catheter is then inserted into the patient's vasculature and moved so as to position the collapsed stent at the location of the native valve. A deployment mechanism is activated that expands the stent containing the replacement valve against the valve cusps. The expanded structure includes a stent configured to have a valve shape with valve leaflet supports begins to take on the function of the native valve. As a result, a full valve replacement has been achieved but at a significantly reduced physical impact to the patient.

[0006] However, this approach has decided shortcomings. One particular drawback with the percutaneous approach disclosed in the Andersen '614 patent is the difficulty in preventing leakage around the perimeter of the new valve after implantation. Since the tissue of the native valve remains within the lumen, there is a strong likelihood that the commissural junctions and fusion points of the valve tissue (as pushed apart and fixed by the stent) will make sealing around the prosthetic valve difficult. In practice, this has often led to severe leakage of blood around the stent apparatus.

[0007] Other drawbacks of the Andersen '614 approach pertain to its reliance on stents as support scaffolding for the prosthetic valve. First, stents can create emboli when they expand. Second, stents are typically not effective at trapping the emboli they dislodge, either during or after deployment. Third, stents do not typically conform to the features of the native lumen in which they are placed, making a prosthetic valve housed within a stent subject to paravalvular leakage. Fourth, stents are subject to a tradeoff between strength and compressibility. Fifth, stents cannot be retrieved once deployed. Sixth, the inclusion of the valve within the stent necessarily increases the collapsed diameter of the stent-valve complex and increases the caliber of the material that must be delivered into the vasculature.

[0008] As to the first drawback, stents usually fall into one of two categories: self-expanding stents and expandable stents. Self-expanding stents are compressed when loaded into a catheter and expand to their original, non-compressed size when released from the catheter. These are typically made of Nitinol. Balloon expandable stents are loaded into a catheter in a compressed but relaxed state. These are typically made from stainless steel or other malleable metals. A balloon is placed within the stent. Upon deployment, the catheter is retracted and the balloon inflated, thereby expanding the stent to a desired size. Both of these stent types exhibit significant force upon expansion. The force is usually strong enough to crack or pop thrombosis, thereby causing pieces of atherosclerotic plaque to dislodge and become emboli. If the stent is being implanted to treat a stenosed vessel, a certain degree of such expansion is desirable. However, if the stent is merely being implanted to displace native valves, less force may be desirable to reduce the chance of creating emboli.

[0009] As to the second drawback, if emboli are created, expanded stents usually have members that are too spaced apart to be effective to trap any dislodged material. Often, secondary precautions must be taken including the use of nets and irrigation ports.

[0010] The third drawback is due to the relative inflexibility of stents. Stents typically rely on the elastic nature of the native vessel to conform around the stent. Stents used to open a restricted vessel do not require a seal between the vessel and the stent. However, when using a stent to displace native valves and house a prosthetic valve, a seal between the stent and the vessel is necessary to prevent paravalvular leakage. Due to the non-conforming nature of stents, this seal is hard to achieve, especially when displacing stenosed valve leaflets.

[0011] The fourth drawback is the tradeoff between compressibility and strength. Stents are made stronger or larger by manufacturing them with thicker members. Stronger stents are thus not as compressible as weaker stents. Most stents suitable for use in a valve are not compressible enough to be placed in a small diameter catheter, such as a 20Fr, 16Fr or even 14Fr catheter. Larger delivery catheters are more difficult to maneuver to a target area and also result in more trauma to the patient.

[0012] The fifth drawback of stents is that they are not easily retrievable. Once deployed, a stent may not be recompressed and drawn back into the catheter for repositioning due to the non-elastic deformation (stainless steel) or the radial force required to maintain the stent in place (Nitinol). Thus, if a physician is unsatisfied with the deployed location or orientation of a stent, there is little he or she can do to correct the problem.

[0013] The sixth drawback listed above is that the combination of the valve within the stent greatly increases the size of the system required to deliver the prosthetic device. As a result, the size of the entry hole into the vasculature is large and often precludes therapy, particularly in children, smaller adults or patients with pre-existing vascular disease.

[0014] The present invention addresses these drawbacks. Specifically, the present invention provides a support structure that expands gently, with gradual force, thereby minimizing the generation of emboli.

[0015] The present invention also provides a support structure that traps any emboli generated, thereby preventing the emboli from causing damage downstream.

[0016] Furthermore, the present invention provides a support structure that conforms to the features of the lumen in which it is being deployed, thereby preventing paravalvular leakage.

[0017] The present invention also provides a strong support structure capable of being deployed from a very small diameter catheter.

[0018] Additionally the invention provides a support structure that is capable of being retracted back into a delivery catheter and redeployed therefrom.

[0019] The invention further provides a device that is delivered with the valve distinctly separated from the inside diameter of the final configuration of the support structure in order to reduce the amount of space required to deliver the device within the vasculature of the patient.

[0019a] The discussion of documents, acts, materials, devices, articles and the like is included in this specification solely for the purpose of providing a context for the present invention. It is not suggested or represented that any or all of these matters formed part of the prior art base or were common general knowledge in the field relevant to the present invention as it existed before the priority date of each claim of this application.

BRIEF SUMMARY OF THE INVENTION

[0020] In one aspect the present invention provides a stentless support structure comprising: at least one strand braided to form a tubular structure having a first configuration and a second configuration; whereby in the first configuration, the tubular structure includes: a first end and a second end; an elongate body between the first end and the second end; whereby in the second configuration, the tubular structure includes at least one fold creating a section of the body having more than one ply.

[0020a] In another aspect the present invention provides a method of implanting a support structure comprising: (a) percutaneously delivering a support structure in an elongated state inside a catheter to a target site; (b) retracting said catheter relative to said support structure such that a first portion of said support structure expands against native tissue of the target site; (c) advancing a second portion of said support structure into said first portion such that a first fold is created between said first and second portions; (d) retracting said catheter relative to said second portion until said second portion expands against an interior of said first portion, thereby creating a multi-layered support structure; (e) repeating steps (c) and (d) if additional layers are desired; (f) releasing the support structure and removing said catheter from the target site.

[0020b] In another aspect the present invention provides a stentless support structure comprising: a strand braided to form a tubular structure having a first configuration and a second configuration; whereby in the first configuration, the tubular structure includes: a first end and a second end; an elongate tubular body between the first end and the second end; whereby in the second configuration, the tubular structure includes: at least one fold shortening the body and creating a section of the body having at least twice as many ply as the elongate body in the extended configuration.

[0020c] In a further aspect the present invention provides a method of implanting a support structure comprising: (a) percutaneously delivering a support structure in an elongated state inside a catheter to a target site; (b) retracting said catheter relative to said support structure such that a first portion of said support structure expands outside of said catheter; (c) advancing a second portion of said support structure into said first portion such that a first fold is created between said first and second portions; (d) retracting said catheter relative to said second portion until said second portion expands against an interior of said first portion, thereby creating a multi-layered support structure; (e) repeating steps (c) and (d) if additional layers are desired; (f) releasing the support structure and removing said catheter from the target site.

[0020d] Accordingly, the present invention provides a tubular mesh support structure for a native lumen that is capable of being delivered via a very small diameter delivery catheter. The tubular mesh is formed one or more fine strands braided together into an elongate tube. The strands may be fibrous, non-fibrous, multifilament, or monofilament. The strands exhibit shape memory such that the elongate tube may be formed into a desired folded shape, then stretched out into a very small diameter, elongated configuration. The small diameter, elongated configuration makes a very small diameter delivery catheter possible.

[0021] Upon deployment, the elongated tube is slowly pushed out of the delivery catheter, where it gradually regains its folded, constructed configuration. The tube conforms to the internal geometries of the target vessel, in addition, the braid effectively traps all emboli that may be released from the vessel walls.

[0022] As the tube continues to be pushed from the delivery catheter, it begins to fold in upon itself as it regains its constructed configuration. As it folds in upon itself, the forces exerted by each layer add together, making the structure incrementally

stronger. Thus, varying levels of strength may be achieved without changing the elongated diameter of the device.

[0023] Using this folded tube, the valve can be attached such that the valve or other structure (such as a filter) in its elongated configuration within the delivery catheter does not reside within the elongated tube, but on deployment can be positioned in, above or below the tube.

BRIEF DESCRIPTION OF THE DRAWINGS

[0024] Figure 1 is a perspective view of a preferred embodiment of the present invention in an elongate configuration;

[0025] Figure 2 is a side view of a preferred embodiment of the present invention;

[0026] Figures 3-12 are a sequence of perspective views of a preferred embodiment of the present invention being deployed from a delivery catheter;

[0027] Figure 13 is a perspective view of a preferred embodiment of the present invention;

[0028] Figure 14 is a first end view of the preferred embodiment of Figure 13;

[0029] Figure 15 is a second end view of the preferred embodiment of Figure 13;

[0030] Figure 16 is a side view of a preferred embodiment of the present invention;

[0031] Figure 17 is a second end view of the preferred embodiment of Figure 16;

- [0032] Figure 18 is a first end view of the preferred embodiment of Figure 16;
- [0033] Figure 19 is a side view of a preferred embodiment of the present invention;
- [0034] Figure 20 is a first end view of the preferred embodiment of Figure 19;
- [0035] Figure 21 is a second end view of the preferred embodiment of Figure 19;
- [0036] Figure 22 is a partial perspective view of a preferred embodiment of the present invention;
- [0037] Figure 23 is a partial perspective view of a preferred embodiment of the present invention;
- [0038] Figure 24 is a perspective view of a preferred embodiment of the present invention;
- [0039] Figure 25 is a side elevation of the embodiment of Figure 24;
- [0040] Figure 26 is a second end view of the embodiment of Figure 24;
- [0041] Figures 27-36 are a sequence of perspective views of a preferred embodiment of the present invention being deployed from a delivery catheter against a clear plastic tube representing a native valve;
- [0042] Figure 37 is a side elevation of a preferred embodiment of the present invention;
- [0043] Figure 38 is an end view of a downstream side of the embodiment of Figure 37;
- [0044] Figure 39 is an end view of an upstream side of the embodiment of Figure 37.

DETAILED DESCRIPTION OF THE INVENTION

[0045] Referring now to the Figures and first to Figure 1, there is shown a stentless support structure 10 of the present invention in an extended configuration. The valve support 10 includes a first end 12, a second end 14 and an elongate tubular body 16 extending between the first end 12 and the second end 14.

[0046] The elongate tubular body 16 is preferably formed from one or a plurality of braided strands 18. The braided strands 18 are strands of a super-elastic or shape memory material such as Nitinol. The strands are braided to form a tube having a central lumen 20 passing therethrough.

[0047] In one embodiment, the tubular body 16 is folded in half upon itself such that the second end 14 becomes a folded end and the first end 12 includes a plurality of unbraided strands. The tubular body 16 is thus two-ply. The unbraided strands of the first end 12 are gathered and joined together to form a plurality of gathered ends 22. The gathered ends 22 may be used as commissural points for attaching a prosthetic valve to the support structure 10. (See, e.g. Figure 2). Alternatively, as shown in Figure 1, the gathered ends 22 may be used as attachment points for a wireform 24 defining a plurality of commissural points 26.

[0048] Notably, the commissural points 26 are positioned such that, when a valve is attached to the support structure in the extended configuration, the valve is longitudinally juxtaposed with the support structure rather than being located within the support structure. This juxtaposition allows the support structure 10 and valve to be packed into a very small catheter without damaging the delicate valve. This longitudinal juxtaposition may be maintained when the support structure assumes a folded or constructed configuration (see Fig. 19 for example), or the valve may become folded within the support structure.

[0049] Figures 3-6 show the second end 14 emerging from the catheter 28 to expose a first layer 30. In Figure 7, the first layer 30 is completely exposed and has assumed its constructed configuration. Notably, the first layer 30 contracts

longitudinally when fully deployed. Also shown in Figure 7 is a second layer 32 beginning to emerge from the catheter 28. As the second layer exits the catheter, the pre-set super-elastic fold inverts the mesh, such that a second, inner layer is formed within the first outer layer. Alternatively, the first layer can be deployed against the wall of the vascular structure (such as an artery, vein, valve or heart muscle). As the second layer exits the catheter, the physician can aid inversion of the mesh by advancing the deployment system. In another embodiment, the mesh support structure can be advanced in the vasculature such that it is deployed in a reverse direction (such as deployment through the apex of the heart ventricle or from the venous system), where the mesh inversion occurs as a result of pulling or retracting the deployment system.

[0050] In Figure 10, the second layer 32 is fully deployed and the third layer 34 is fully exposed, but has not yet been inverted. Retracting the catheter 28, relative to the device 10, while advancing the catheter 28 slightly, relative to the target site, causes the third layer 34 to "pop" inwardly, thereby inverting itself against an inside surface of the second layer 32, as seen in Figure 11.

[0051] In Figure 12, additional material has been ejected from the catheter 28 such that the third layer 34 is fully expanded against the second layer. One skilled in the art will realize that numerous additional layers can be achieved in this manner, and that each layer adds additional radial strength to the resulting support structure 10.

[0052] Throughout the deployment process, the stentless support structure 10 emerges from the delivery catheter 28 gradually. This characteristic also allows the structure 10 to be pulled back into the delivery catheter 28, in the event that it is desired to relocate the support structure 10. Doing so causes the support structure 10 to reacquire its extended configuration.

[0053] Having described the mechanics of building a support structure in situ, attention can now be turned to various embodiments made possible by the present

invention. Figures 13-15 show a support structure 10 having many layers 38 and a first end 12 with numerous gathered ends 22 formed from unbraided strands. Some of the gathered ends 22 are attached to a wireform 24 having three commissural points 26. A prosthetic valve 36, either harvested or manufactured, is attached to the wireform 24. Figure 15 shows the internal lumen 20 of the support structure 10.

[0054] Figures 16-18 show a support structure 10 having fewer layers 38 and a wireform 24 with a prosthetic valve 36 attached thereto. The first end 12 (hidden), to which the wireform 24 is attached, has been preformed to fold inwardly upon deployment. Thus, the wireform 24 and prosthetic valve 36, is located in the inner lumen 20 of the support structure 10 when the support structure 10 is in a constructed configuration.

[0055] Figures 19-21 show a support structure 10 with several layers 38 and a first end 12 preformed to have a smaller diameter than the rest of the layers and the second end 14, which is folded. The terminal ends of the braided strands at the first end 12 have not been formed into gathered ends. Rather, the wireform 24 is attached to the braids. The prosthetic valve 36 is attached to the wireform 24 and has skirting tissue 40, which is placed around the outside of the end 12. The skirting tissue 40 may be adhered to the first end 12.

[0056] Figure 22 shows a stentless support structure 10 with a folded end 14, which has been folded back on itself, and a material 42 trapped between the two layers of the fold. The material 42 is provided to further improve the paravalvular leak prevention and embolic trapping characteristics of the stentless support structure 10. The material 42 could consist of a non-woven material, woven or braided fabric, a polymer or other material.

[0057] Figure 23 shows a stentless support structure 10 that includes a fiber 44 that is larger than the rest of the strands comprising the support structure 10. Thus, Figure 23 demonstrates that strands of different sizes may be used in the braided support structure 10 without significantly affecting the minimum delivery size of the

device. Different sized strands may be used in order to improve strength, provide stiffness, create valve attachment points, provide radiopaque markers, and the like.

[0058] Figures 24-26 show a stentless support structure 10 that has a first end 12 that has had the unbraided strands trimmed such that they do not extend past the first end 12 of the folded structure 10. This embodiment may be used to create, preserve or enlarge a lumen. A prosthetic valve may or may not be attached to this embodiment.

[0059] Turning now to Figures 27-36, a deployment sequence of a preferred embodiment of the stentless support structure 10 is shown whereby a clear piece of tubing 46 is used to demonstrate a targeted location of a native vessel, such as a native valve. In Figure 27, the delivery catheter 28 is advanced beyond the targeted valve 46 and the stentless support 10 is starting to be ejected from the catheter 28.

[0060] In Figure 28, enough of the stentless support 10 has been ejected that the second, folded end 14 has begun to curl back on itself slightly, forming a cuff 48. In Figure 29, the cuff 48 is more visible and has assumed its full, deployed shape. The cuff 48 acts as a catch that a physician can use to visually or tactilely locate the targeted valve 46 and seat the stentless support 10 thereagainst. The cuff also acts to ensure the entire native lumen through the targeted valve 46 is now being filtered by the support 10. Unlike balloon expandable stents, blood flow is not significantly inhibited by the deployment of the stentless support structure 10. Also shown in Figure 29 is that the first layer 30 has been fully ejected from the catheter 28, as has much of the second layer 32. The first layer 30, being very flexible prior to reinforcement by subsequent layers, is able to conform to any shape of the targeted vessel. The second layer 32 has not yet inverted itself into the first layer 30.

[0061] In Figure 30, the first layer 30 is deployed, the cuff 48 is acting against the valve 46, and the second layer 32 has been inverted. In Figure 31, material forming the third layer 34 is ejected from the catheter 28 but the third layer 34 has not yet inverted.

[0062] In Figures 32-33, the catheter 28 is being advanced to allow the third layer 34 to invert into the second layer 32. The angle of Figure 32 shows the relatively low profile created by the first and second layers 30 and 32, and how little resistance to blood flow is presented by the support structure 10.

[0063] In Figure 34, the first end 12 has emerged from the catheter 12, and the gathered ends 22 are showing. A wireform 24 is attached to some of the gathered ends 22 and is nearly completely deployed from the delivery catheter 28. In Figures 35-36, the support structure 10 has been completely released from the catheter 28. Figure 36 shows the size of the lumen 20 of the support structure 10.

[0064] Figures 37-39 show a preferred embodiment 100 of the present invention including a mesh support structure 102, a wireform 104 and a valve 106. The support structure 102 differs slightly from support structure 10, described previously, as it is constructed from a two individual wires 108. Upon completion of the braiding process, the two free ends of the wire are spliced together. As such, there are no free wire ends and the structure can be loaded into a delivery catheter in a single-ply state (not shown). In the deployed state shown in the Figures, the support structure 102 is folded once to form a two-ply device.

[0065] The support structure 102 is preferably formed of a memory alloy such as Nitinol. The single-wire construction allows the device to be compressed into an extremely small catheter, such as one sized 16Fr or smaller. Though the support structure gains rigidity by the two-ply deployed configuration, radial strength is a function of a several factors and can thus be varied widely.

[0066] First, as with the other embodiments, radial strength may be increased by incorporating more folds or layers into the deployed configuration of the support structure 102. The three-ply configuration shown in Figures 37-39 is the most preferred configuration because it only has to be folded in on itself twice, making deployment less complicated.

[0067] Second, strength may be increased by using a heavier wire. Because the support structure 102 is made from a single-wire, and can thus be loaded into a catheter in a single-ply configuration, a larger diameter wire may be used while maintaining a small diameter elongated profile. Support structures 102 have been constructed according to the present invention using single wires having diameters between 0.005 and 0.010 inches in diameter. Preferably, the diameter of the wire is between 0.007 and 0.008 inches.

[0068] Third, strength may be increased by increasing the braid density. A tighter braid will result in a stronger support.

[0069] Fourth, the strength may be increased by altering the heat setting parameters. Super-elastic and shape memory alloys, such as Nitinol, attain their deformed shape within the vasculature by being heat set. The wires are held in a desired configuration and heated to a predetermined temperature for a predetermined period of time. After the wires cool, they become set to the new configuration. If the wires are later disfigured, they will return to the set configuration upon heating or simply releasing the wires. The force with which a super-elastic or shape memory alloy returns to a set configuration can be increased by modifying the temperature at which the configuration is set, or by modifying the period of time the alloy is maintained at the elevated setting temperature. For example, good results have been attained setting a Nitinol support structure of the present invention at 530°C for 7 minutes. Stiffer support structures can be made using the same Nitinol wire by setting the structure at a temperature other than 530°C or by setting the structure at 530°C for a time other than 7 minutes, or both.

[0070] The device 100 includes a wireform 104, to which a valve 106 is attached. The wireform 104 form commissural points 109 separated by arcuate portions 110. The arcuate portions 110 are attached to an inside surface of the support structure 102. The commissural points 109 facilitate natural and efficient opening and closing of the valve 106. Alternatively, the valve commissural points can be attached to an outer surface of the support structure (not shown).

[0071] The valve 106 may be any form of prosthetic or harvested biological valve. Preferably, as shown in the Figures, the valve 106 is a valve having three leaflets. The valve 106 is sutured or otherwise attached to the wireform 104. Preferably, the valve 106 is cut or constructed to include a skirt portion 112 which continues along the length of the support structure 102 in its deployed configuration.

[0072] Although the invention has been described in terms of particular embodiments and applications, one of ordinary skill in the art, in light of this teaching, can generate additional embodiments and modifications without departing from the spirit of or exceeding the scope of the claimed invention. Accordingly, it is to be understood that the drawings and descriptions herein are proffered by way of example to facilitate comprehension of the invention and should not be construed to limit the scope thereof.

[0073] Throughout the description and claims of this specification, the word "comprise" and variations of the word, such as "comprising" and "comprises", is not intended to exclude other additives, components, integers or steps.

THE CLAIMS DEFINING THE INVENTION ARE AS FOLLOWS:

1. A stentless support structure comprising:
 - at least one strand braided to form a tubular structure having a first configuration and a second configuration;
 - whereby in the first configuration, the tubular structure includes:
 - a first end and a second end;
 - an elongate body between the first end and the second end;
 - whereby in the second configuration, the tubular structure includes at least one fold creating a section of the body having more than one ply.
2. The stentless support structure of claim 1 wherein said at least one fold shortens the body longitudinally in the second configuration.
3. The stentless support structure of claim 1 or claim 2 wherein said tubular structure comprises a single ply in the first configuration.
4. The stentless support structure of any one of claims 1 to 3 wherein said tubular structure comprises a multi-ply section in the second configuration.
5. The stentless support structure of any one of claims 1 to 4 wherein, in the first configuration, said stentless support structure is capable of being housed with a lumen of a 20Fr catheter.
6. The stentless support structure of any one of claims 1 to 5 wherein said first end comprises an unbraided end.
7. The stentless support structure of any one of claims 1 to 6 wherein said second end comprises a folded end.
8. The stentless support structure of any one of claims 1 to 7 wherein said first end comprises a plurality of commissural attachment points.
9. The stentless support structure of any one of claims 1 to 7 wherein said first end comprises a plurality of unbraided strands combined to form at least one commissural attachment point.
10. The stentless support structure of any one of claims 1 to 9 wherein at least one strand braided together to form a tubular structure comprises a plurality of strands of a first diameter and at least one fiber of a second diameter larger than the first diameter.

11. The stentless support structure of any one of claims 1 to 8 wherein said first end comprises a wire form having a plurality of commissural attachment points.

12. The stentless support structure of any one of claims 1 to 11 further comprising a lining in an inner wall of the tubular structure.

13. The stentless support structure of claim 4 further comprising a lining sandwiched between a first and second ply.

14. A method of implanting a support structure comprising:

(a) percutaneously delivering a support structure in an elongated state inside a catheter to a target site;

(b) retracting said catheter relative to said support structure such that a first portion of said support structure expands against native tissue of the target site;

(c) advancing a second portion of said support structure into said first portion such that a first fold is created between said first and second portions;

(d) retracting said catheter relative to said second portion until said second portion expands against an interior of said first portion, thereby creating a multi-layered support structure;

(e) repeating steps (c) and (d) if additional layers are desired;

(f) releasing the support structure and removing said catheter from the target site.

15. The method of claim 14 wherein step (b) comprises retracting said catheter relative to said support structure such that a first portion of said support structure expands against native tissue of the target site, said first portion including a distal end and a proximal end, the distal end including a cuff.

16. The method of claim 15 wherein step (b) comprises:

retracting said catheter relative to said support structure until said cuff expands and contacts the native tissue of the target site;

pulling said cuff in a proximal direction until the cuff contacts a distal side of a native valve;

retracting said catheter relative to said support structure until said proximal side of said first portion expands and contacts the native tissue of the target site.

17. A method of supporting native tissue of a target site comprising:

introducing material into the target site lacking sufficient structural integrity to support the native tissue;

building a stentless support structure according to any one of claims 1 to 13 using said material in situ.

18. The method of claim 17 wherein introducing material into the target site lacking sufficient structural integrity to support the native tissue comprises introducing a braided, elongate mesh tube.

19. The method of claim 18 wherein introducing a braided, elongate mesh tube comprises introducing a braided, elongate mesh tube of at least one strand of a material selected from the group consisting of super-elastic and shape memory.

20. The method of claim 19 wherein introducing a braided, elongate mesh tube of at least one strand of a material selected from the group consisting of super-elastic and shape memory comprises introducing a braided, elongate mesh tube of a single Nitinol strand having been preformed to a folded configuration.

21. The method of any one of claims 17 to 20 wherein building a supporting structure using said material in situ comprises folding said material upon itself until sufficient structural integrity to support the native tissue is attained.

22. The method of claim 21 wherein folding said material upon itself until sufficient structural integrity to support the native tissue is attained comprises: introducing a delivery catheter to the target site containing said material in an elongated form; exposing a first length of said material, thereby allowing said first length of material to expand; advancing a second length of said material inside said first length; exposing said second length of said material, thereby allowing said second length to expand against an inside surface of said first length.

23. The method of claim 22 further comprising: advancing a third length of said material inside said second length; exposing said third length of said material, thereby allowing said third length to expand against an inside surface of said second length.

24. A stentless support structure comprising: a strand braided to form a tubular structure having a first configuration and a second configuration; whereby in the first configuration, the tubular structure includes: a first end and a second end; an elongate tubular body between the first end and the second end; whereby in the second configuration, the tubular structure includes: at least one fold shortening the body and creating a section of the body having at least twice as many ply as the elongate body in the extended configuration.

25. A method of implanting a support structure comprising:

(a) percutaneously delivering a support structure in an elongated state inside a catheter to a target site;

(b) retracting said catheter relative to said support structure such that a first portion of said support structure expands outside of said catheter;

(c) advancing a second portion of said support structure into said first portion such that a first fold is created between said first and second portions;

(d) retracting said catheter relative to said second portion until said second portion expands against an interior of said first portion, thereby creating a multi-layered support structure;

(e) repeating steps (c) and (d) if additional layers are desired;

(f) releasing the support structure and removing said catheter from the target site.

26. The method of claim 25 wherein step (b) comprises retracting said catheter relative to said support structure such that a first portion of said support structure expands against native tissue of the target site, said first portion including a distal end and a proximal end, the distal end including a cuff.

27. The method of claim 26 wherein step (b) comprises:

retracting said catheter relative to said support structure until said cuff expands and contacts the native tissue of the target site;

pulling said cuff in a proximal direction until the cuff contacts a distal side of a native orifice;

retracting said catheter relative to said support structure until said proximal side of said first portion expands and contacts the native tissue of the target site.

28. The method of claim 25 wherein retracting said catheter relative to said support structure such that a first portion of said support structure expands outside of said catheter comprises retracting said catheter relative to said support structure such that a first portion of said support structure expands outside of said catheter against native tissue of the target site.

29. The method of claim 25 wherein step (b) comprises retracting said catheter relative to said support structure such that a first portion of said support structure expands against native tissue belonging to the group consisting of valve tissue, blood vessel tissue, and heart tissue.

30. A stentless support structure according to claim 1 or claim 24, or a method according to any one of claims 14, 17 and 25, substantially as herein described with reference to any one or more of the figures and/or examples

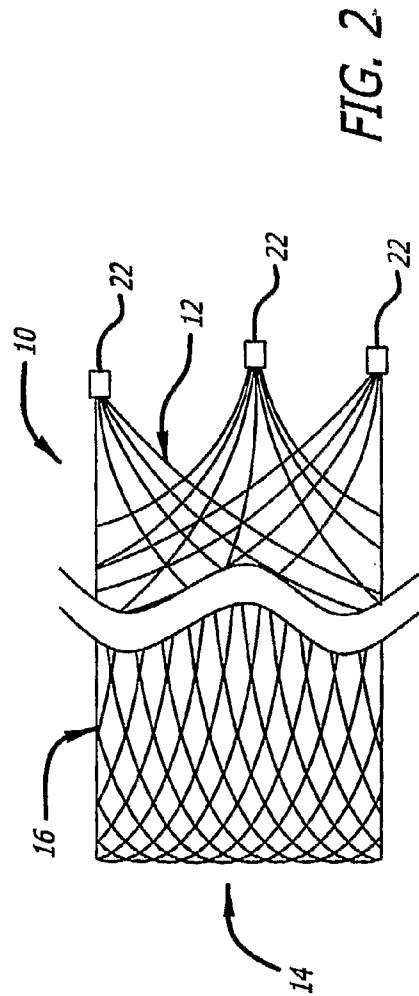
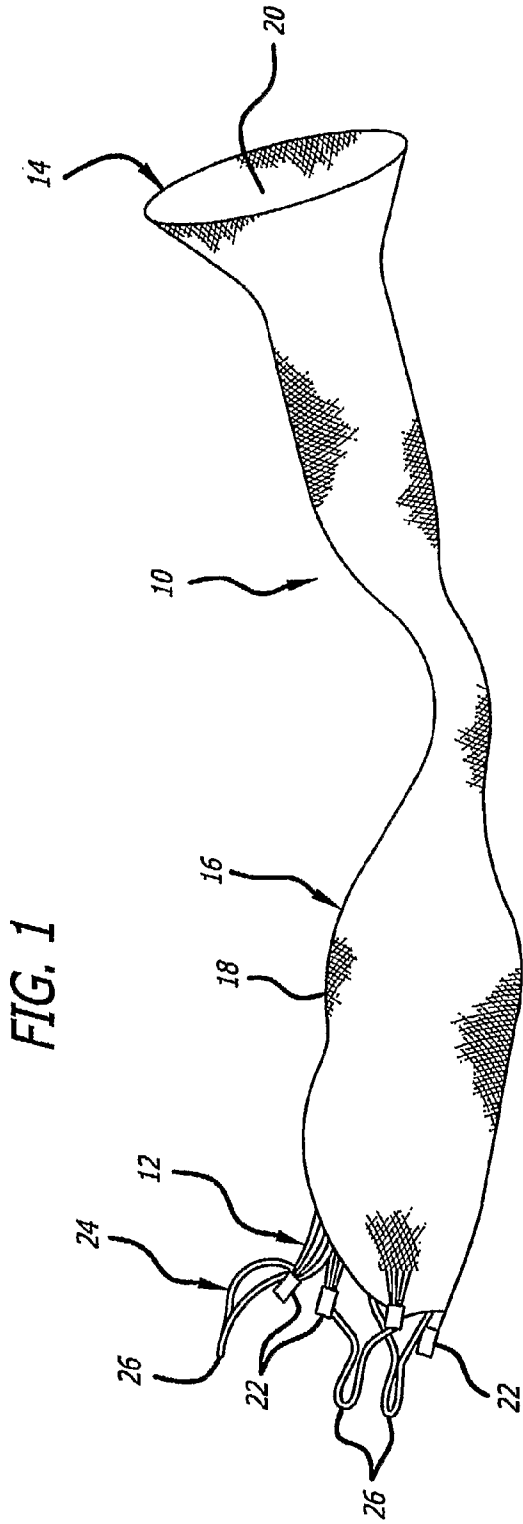

2/18

FIG. 3

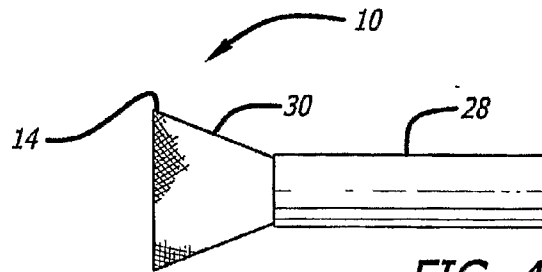
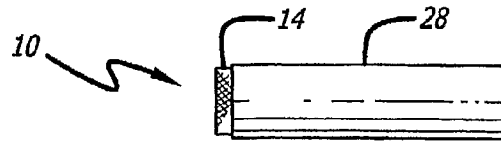

FIG. 4

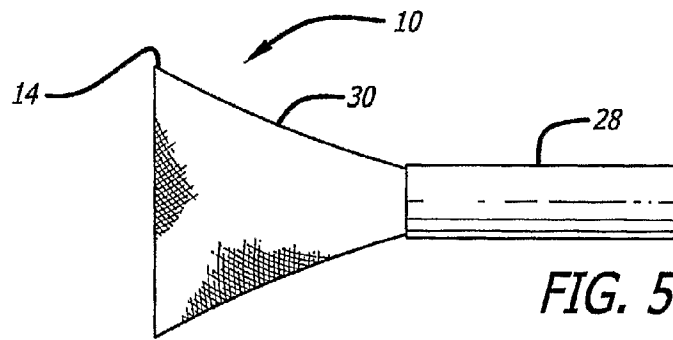

FIG. 5

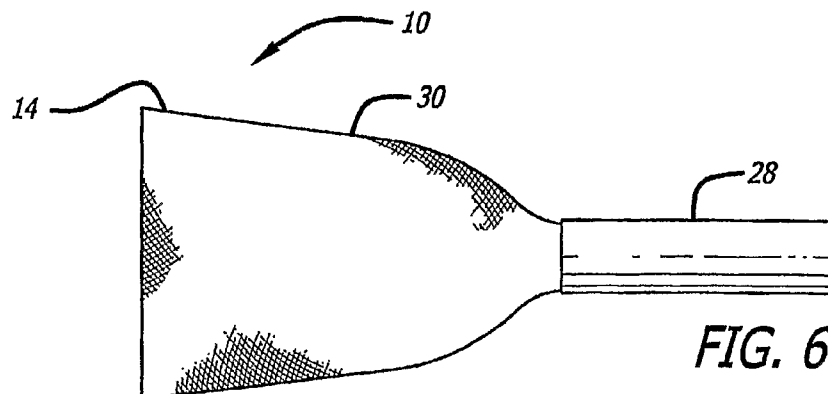

FIG. 6

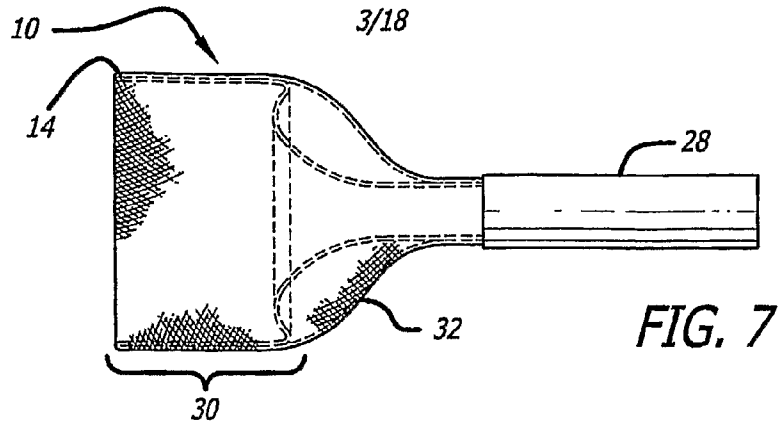

FIG. 7

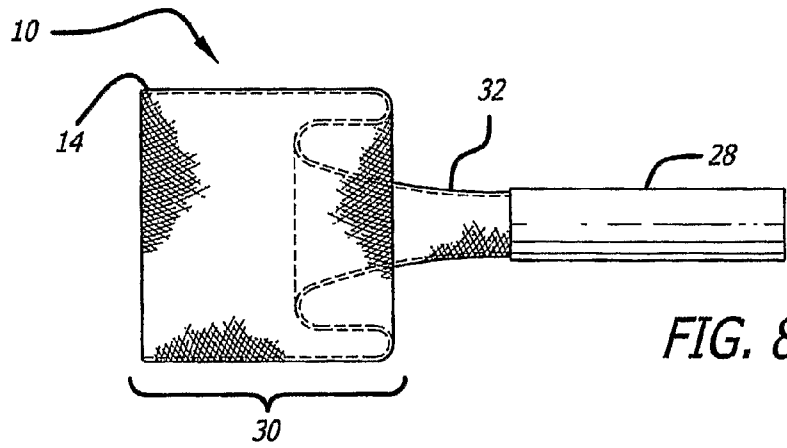

FIG. 8

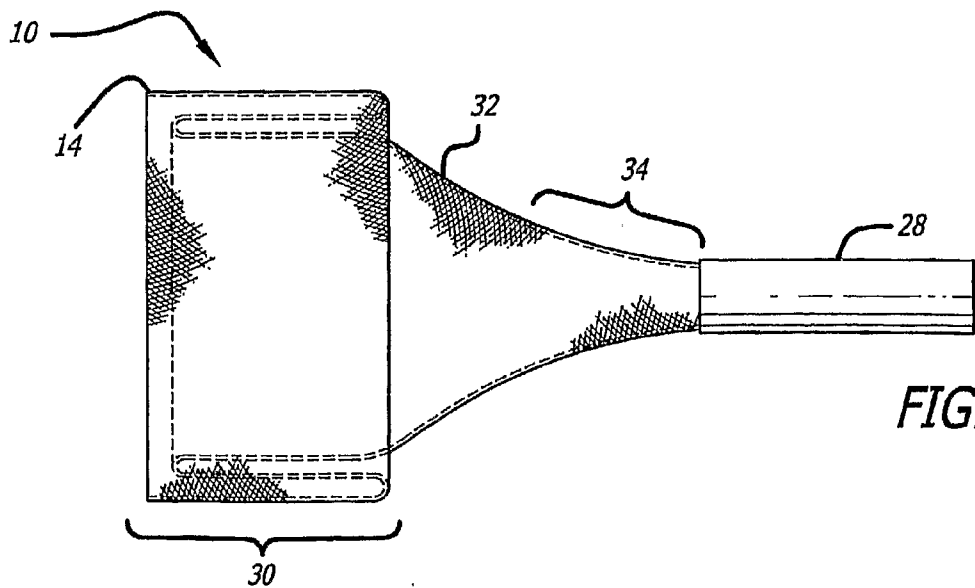
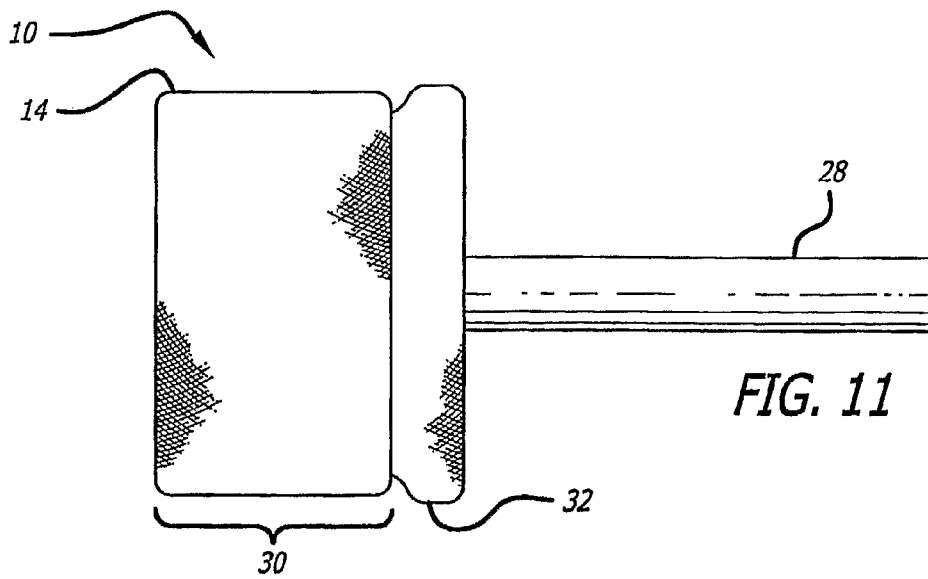
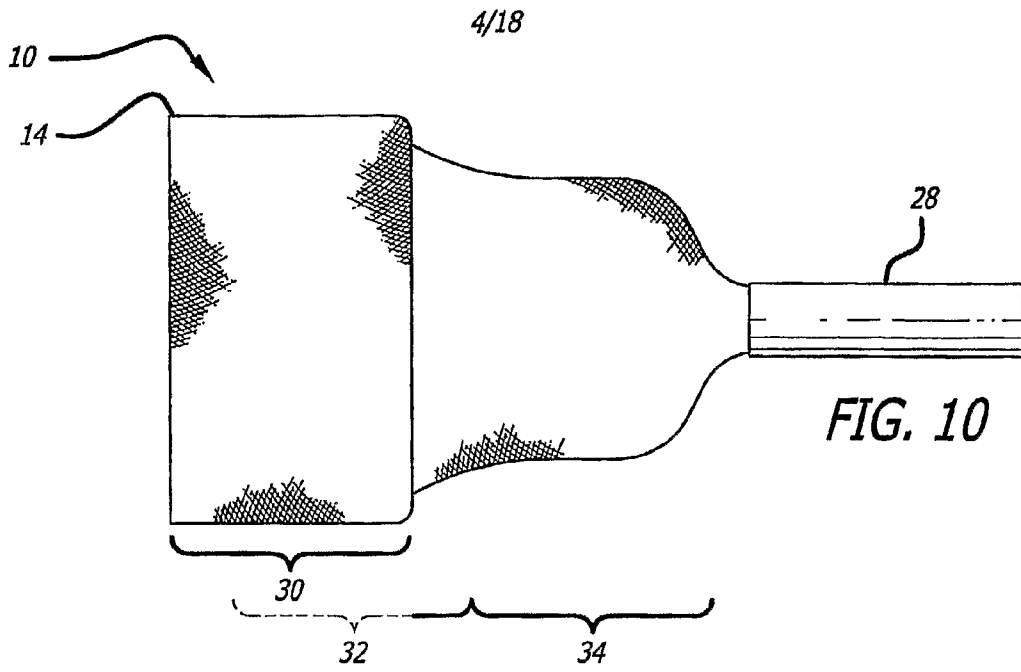

FIG. 9



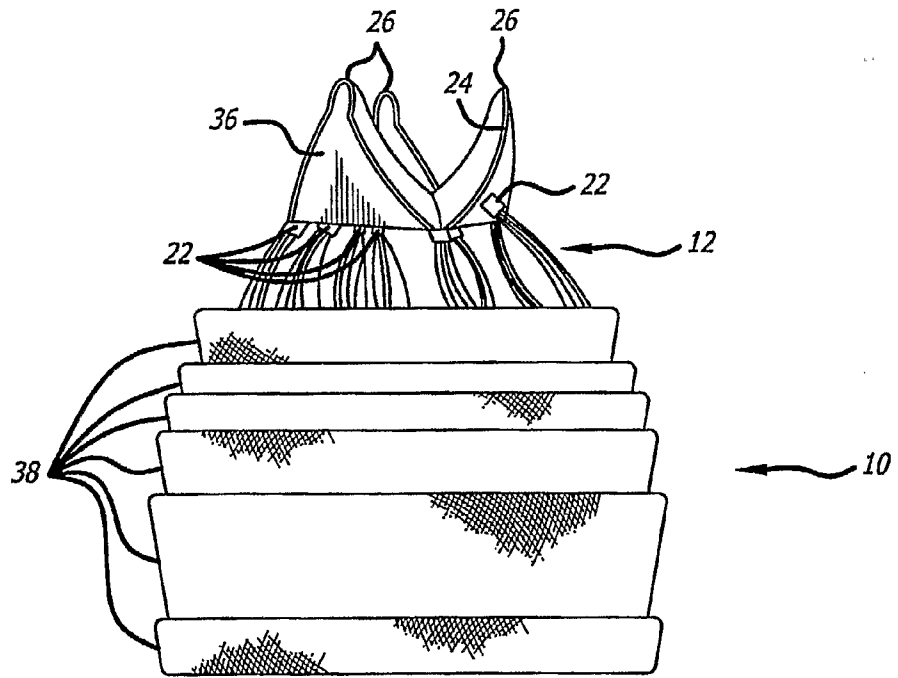
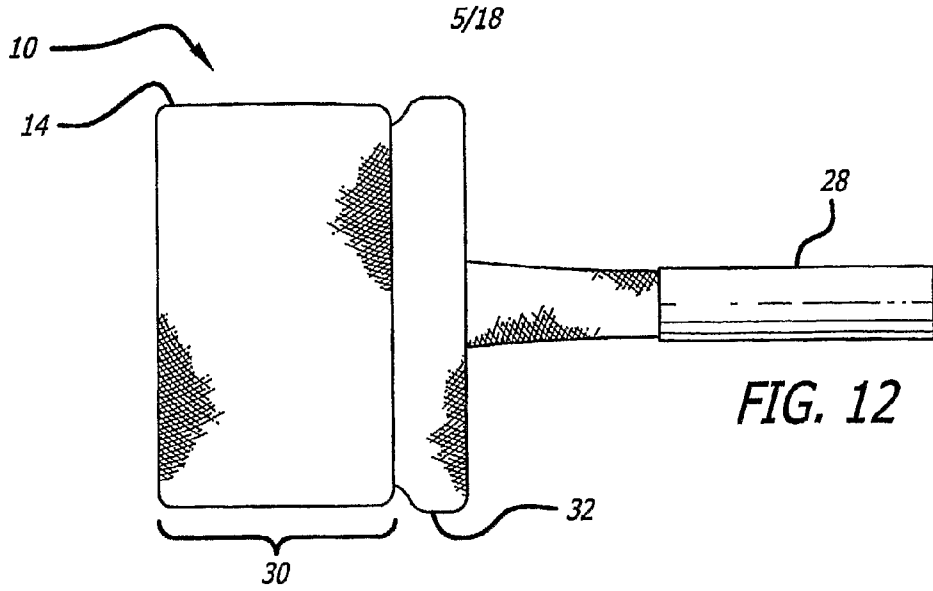

FIG. 13

6/18

FIG. 14

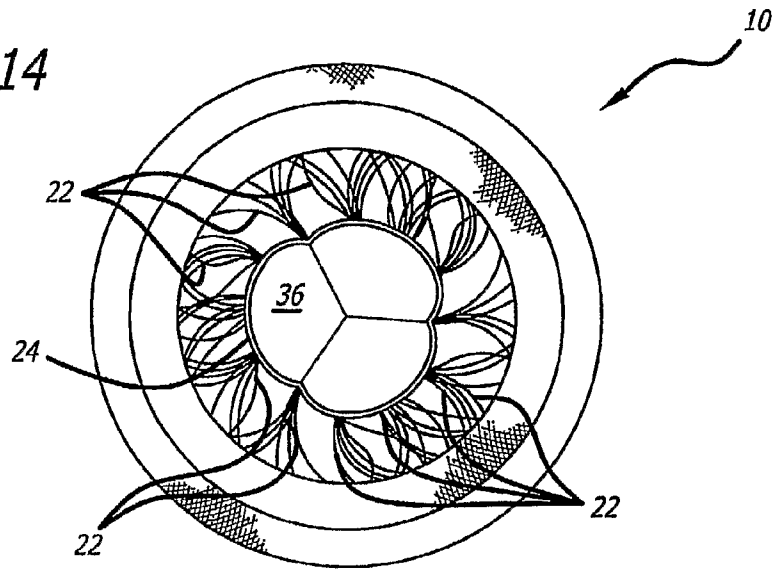
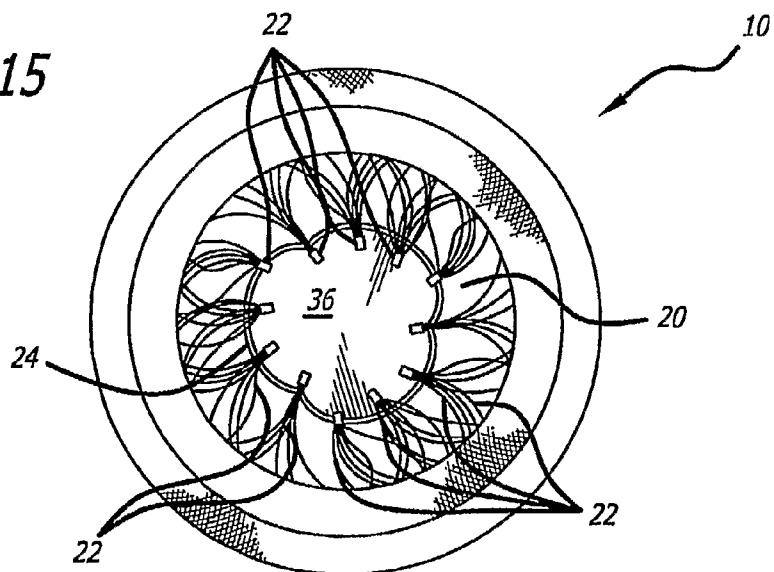

FIG. 15



7/18

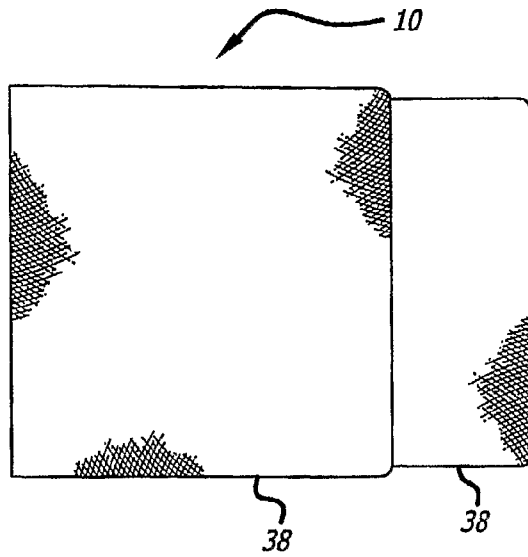

FIG. 16

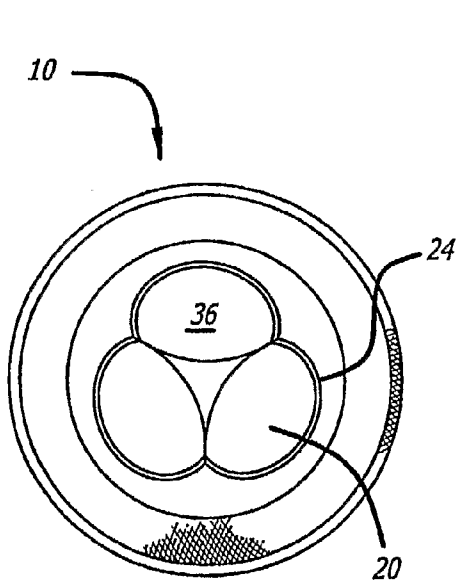

FIG. 17

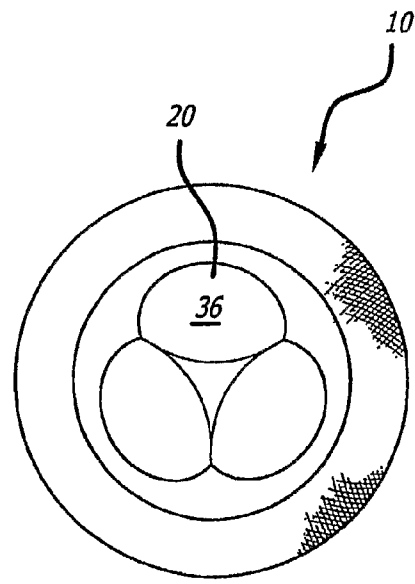

FIG. 18

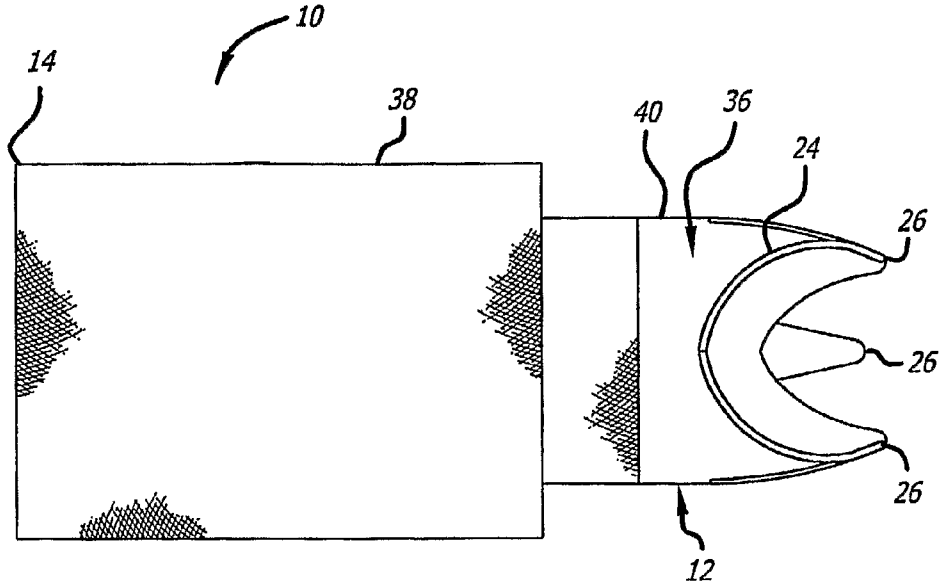

FIG. 19

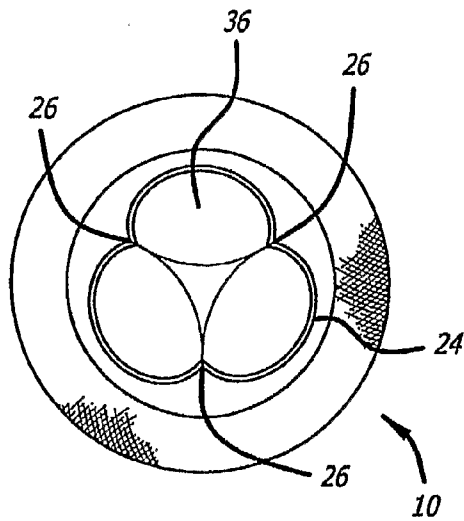

FIG. 20

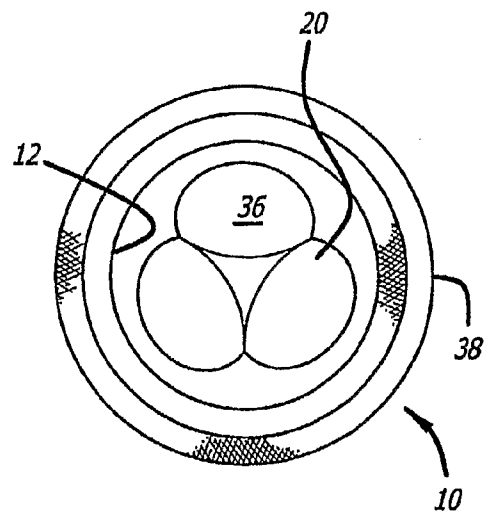

FIG. 21

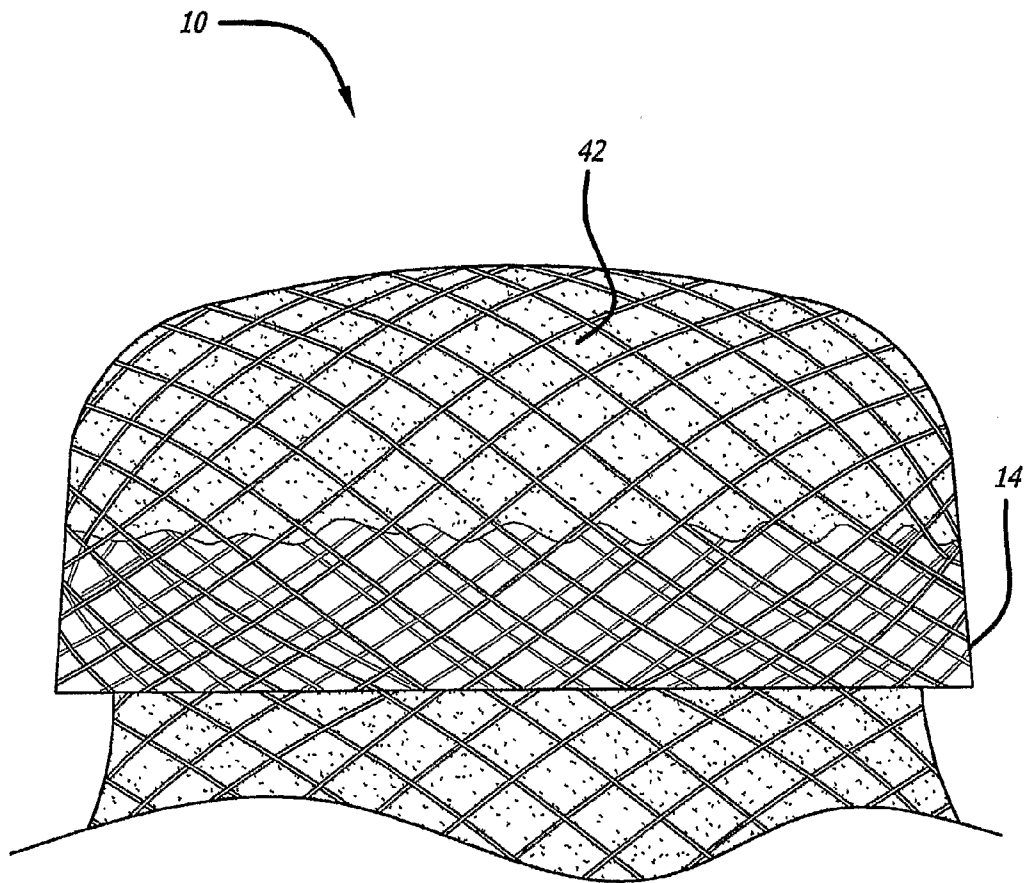

FIG. 22

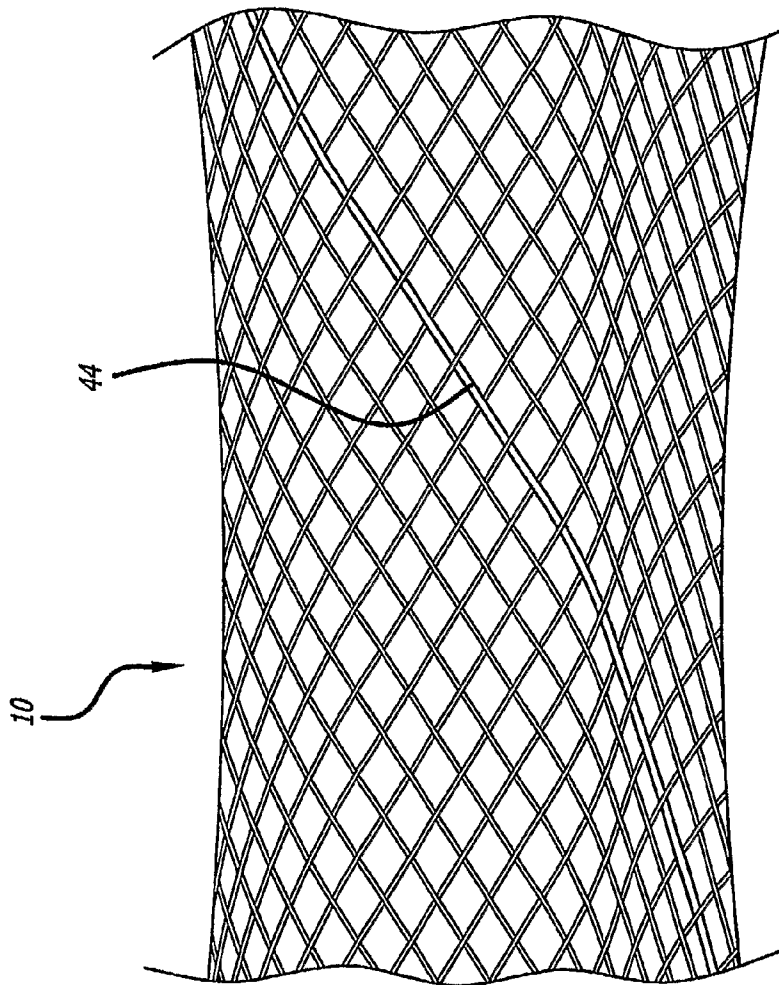

FIG. 23

11/18

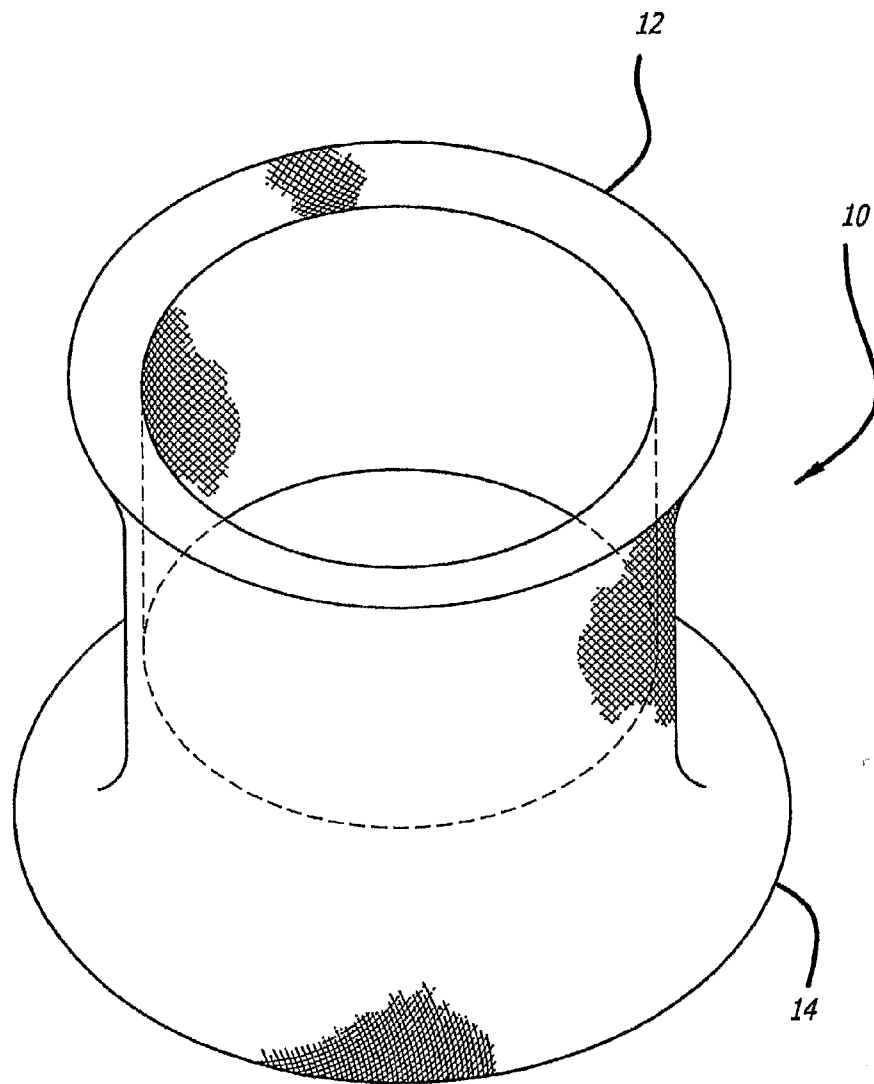

FIG. 24

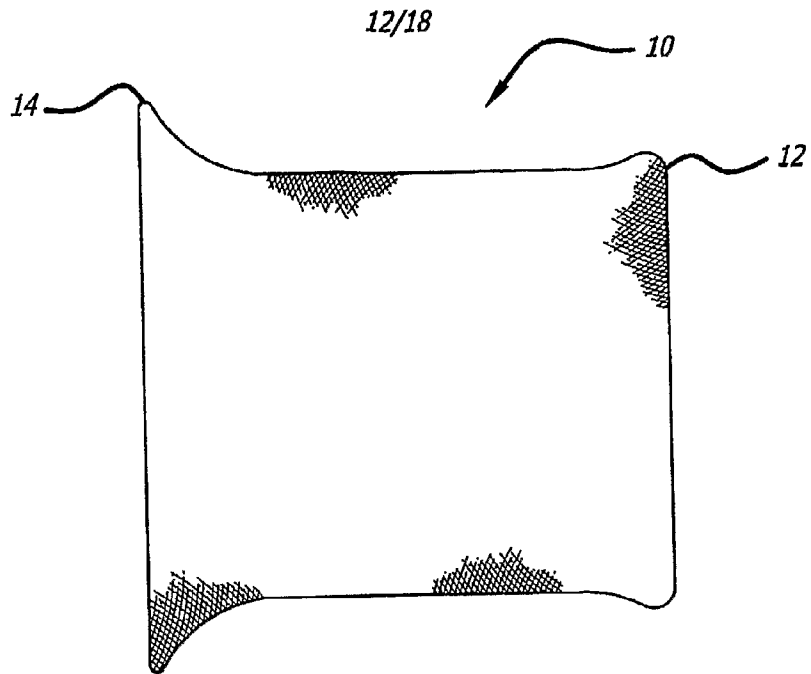

FIG. 25

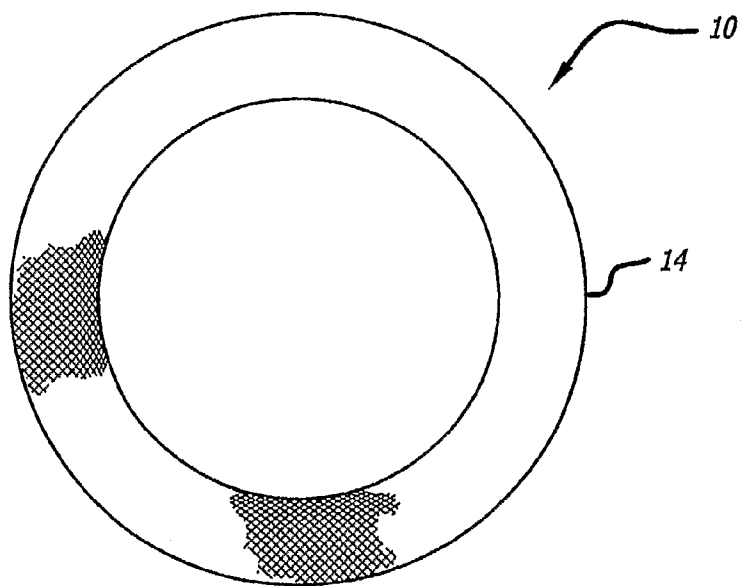

FIG. 26

13/18

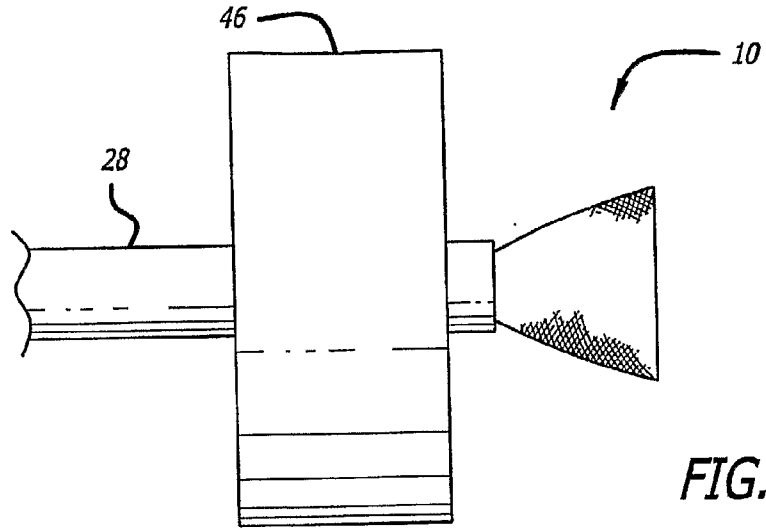

FIG. 27

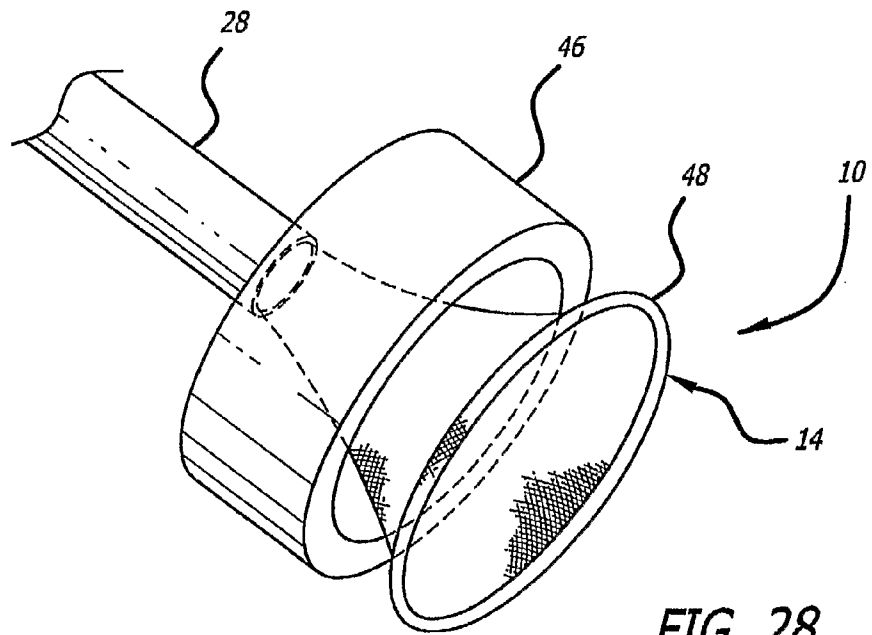
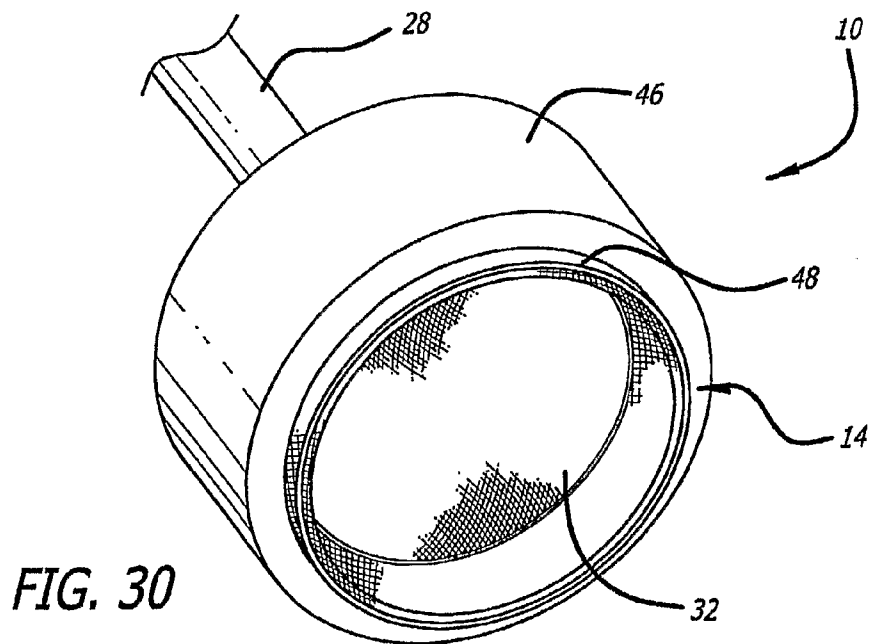
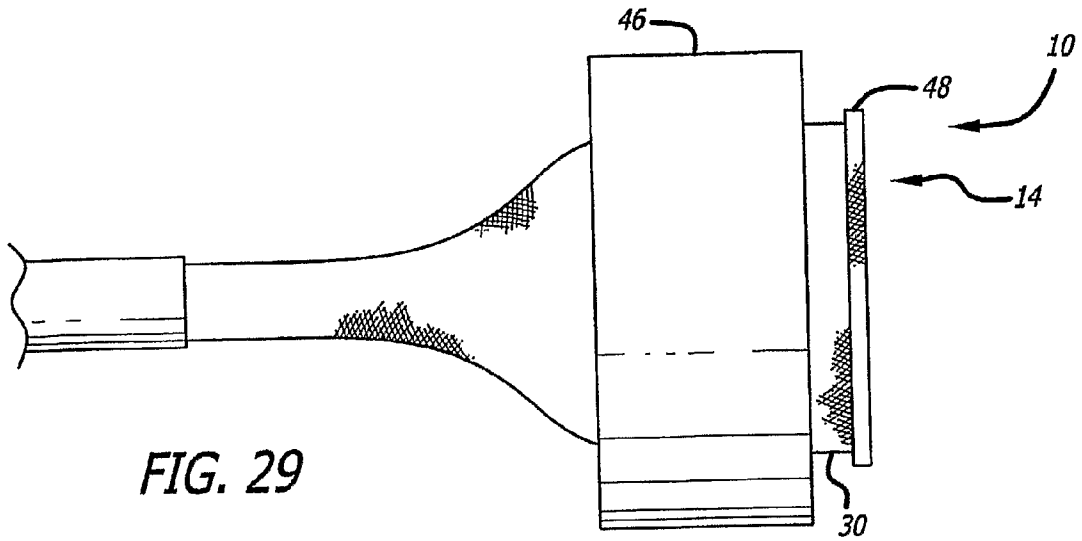
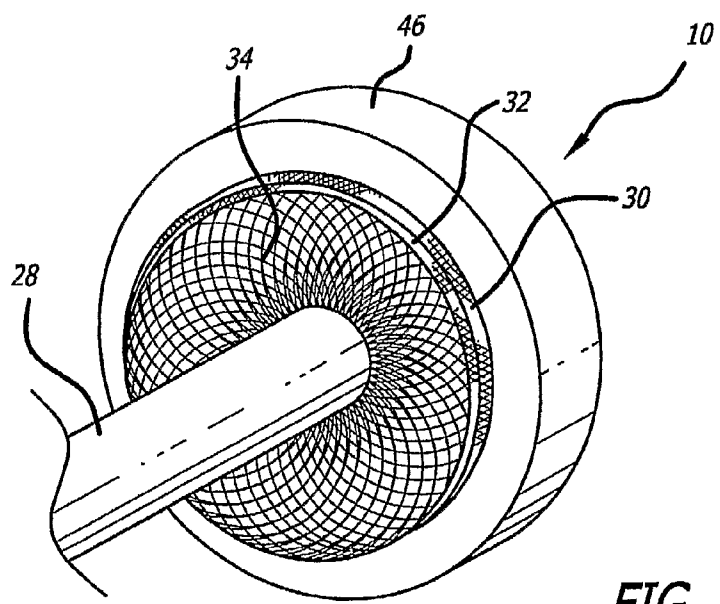
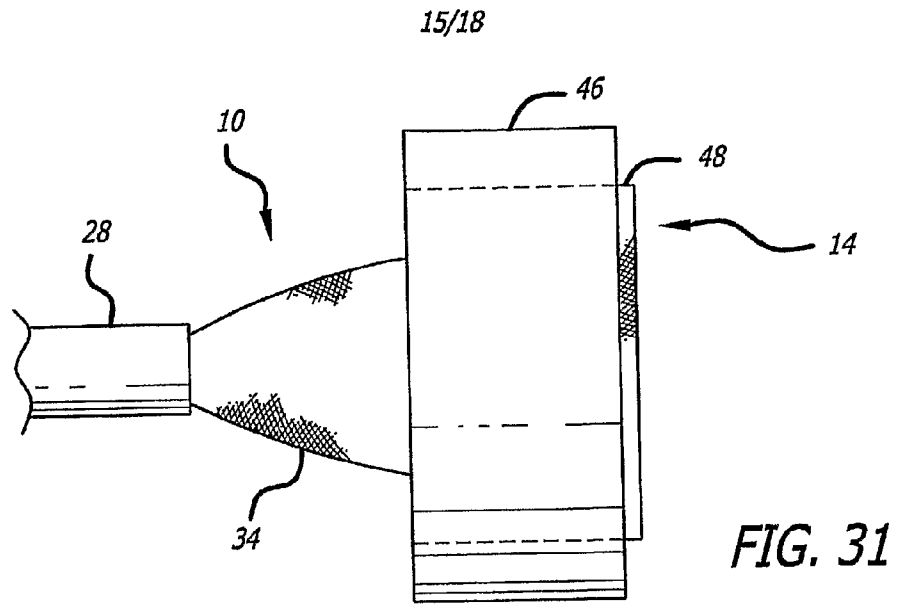
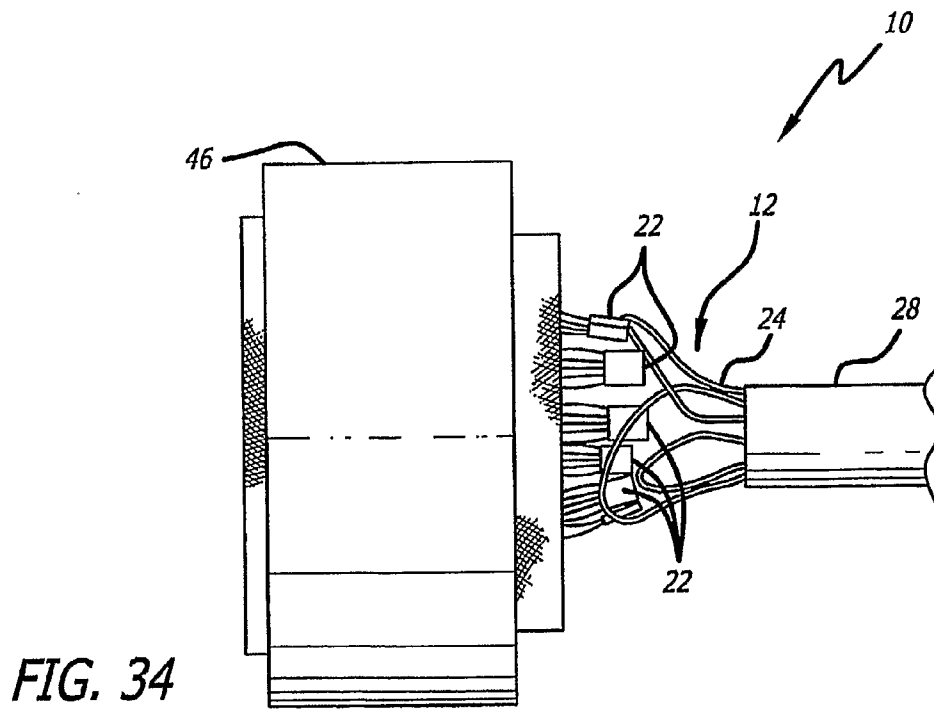
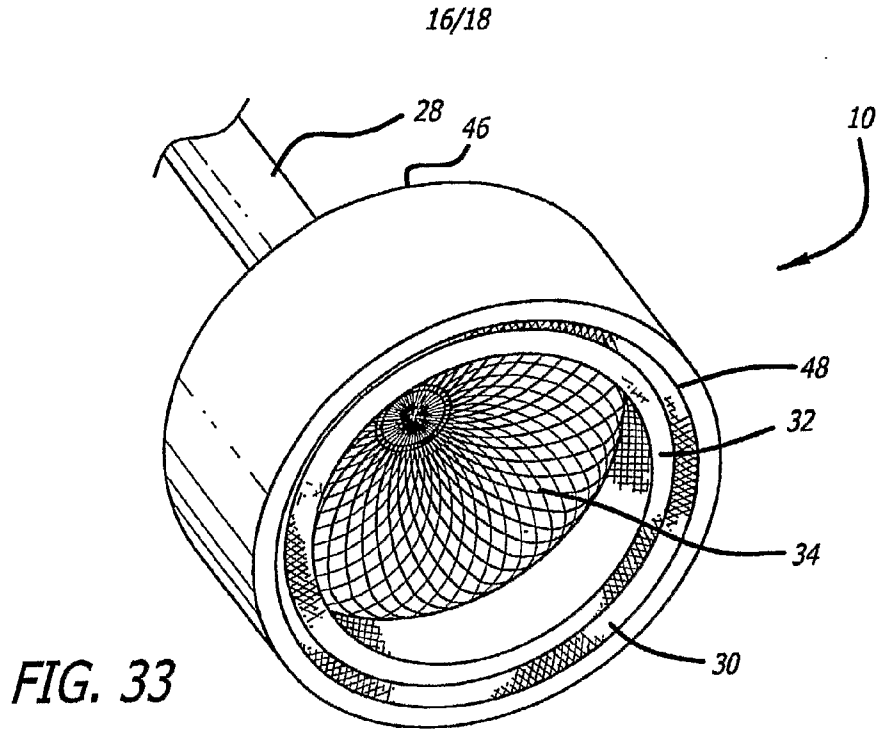

FIG. 28

14/18







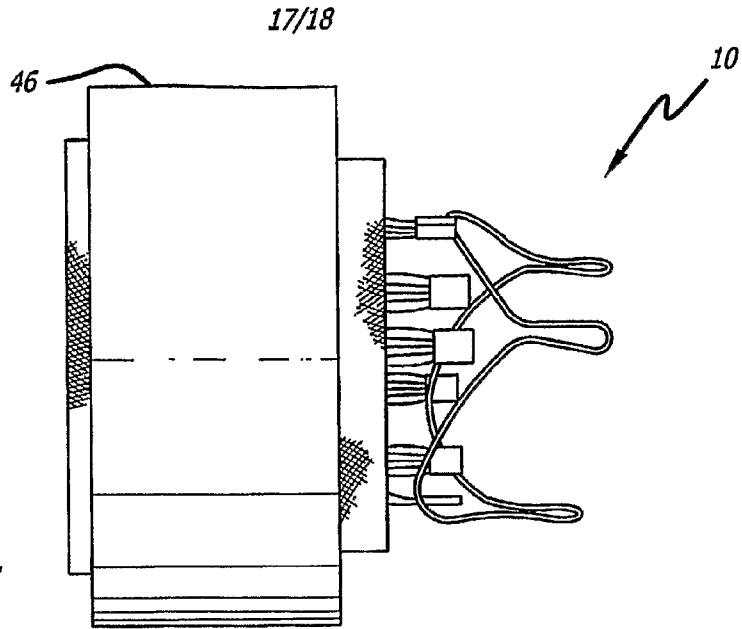

FIG. 35

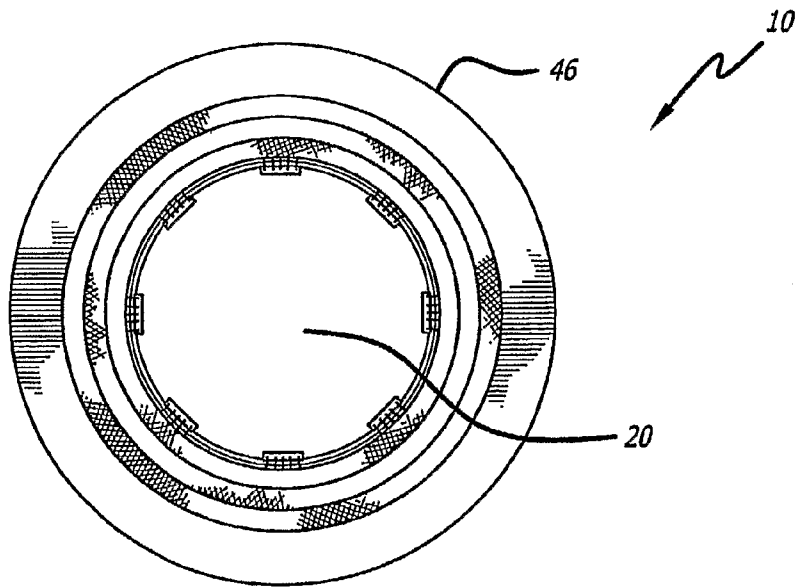

FIG. 36

FIG. 37

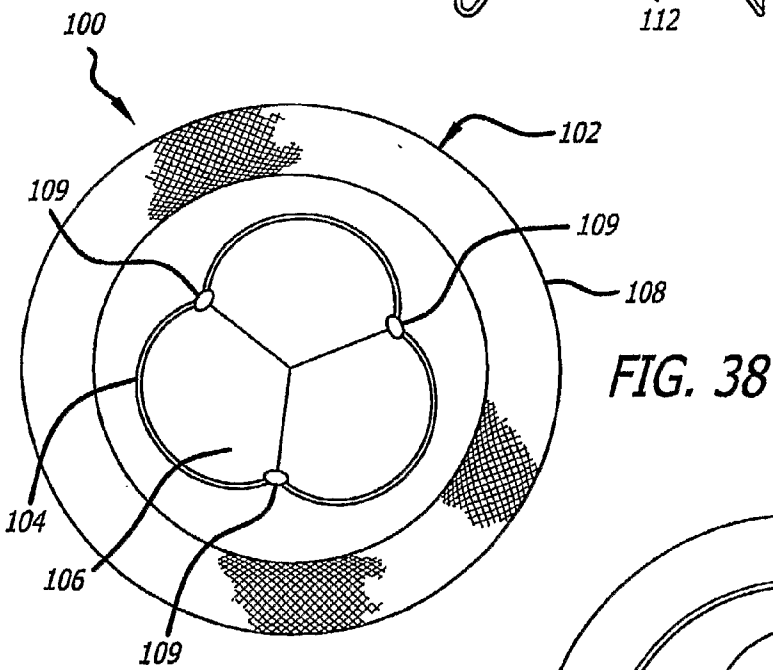
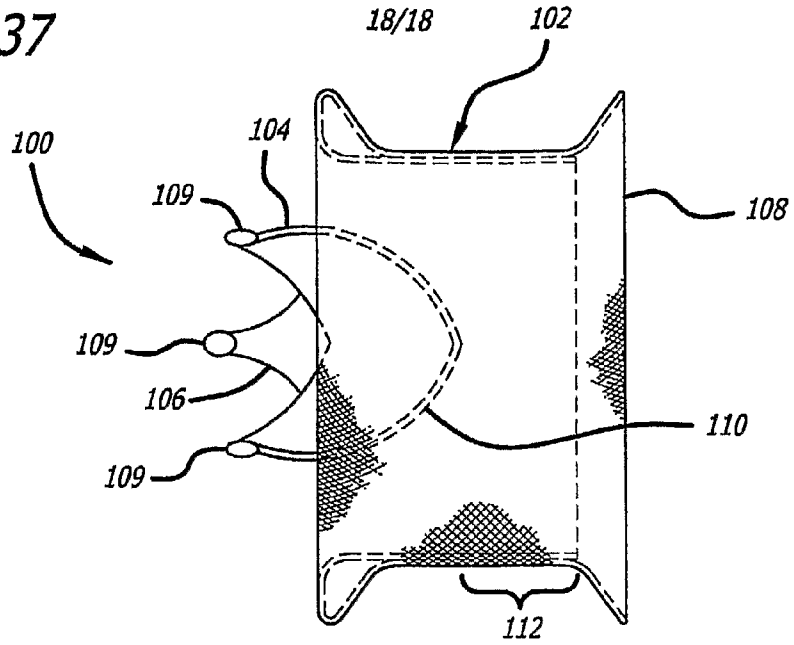

FIG. 38

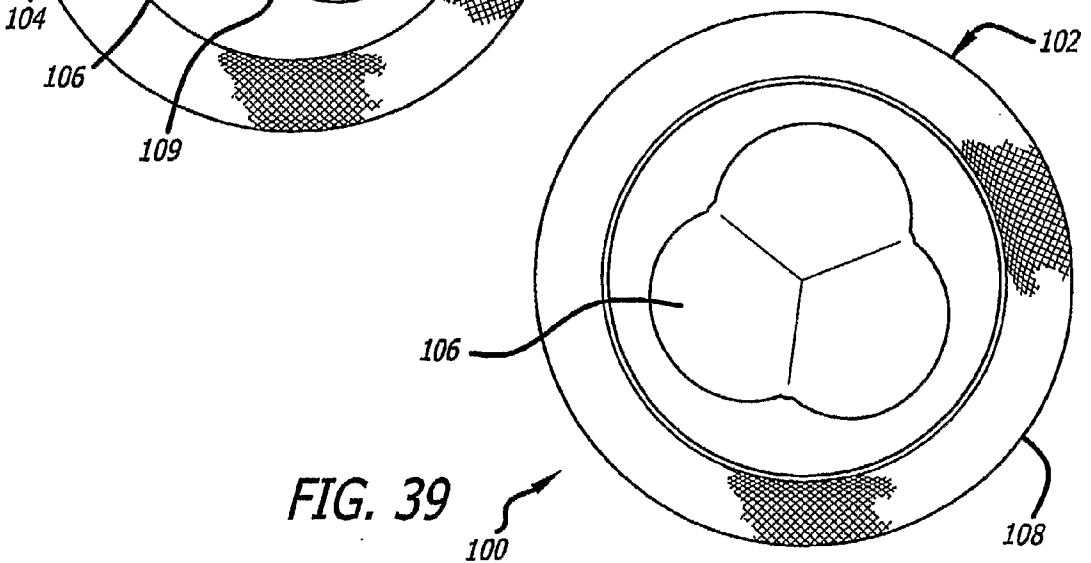

FIG. 39