

July 6, 1948.

A. H. SCHOOLEY

2,444,472

VOLTAGE REGULATOR CIRCUIT

Filed June 19, 1943

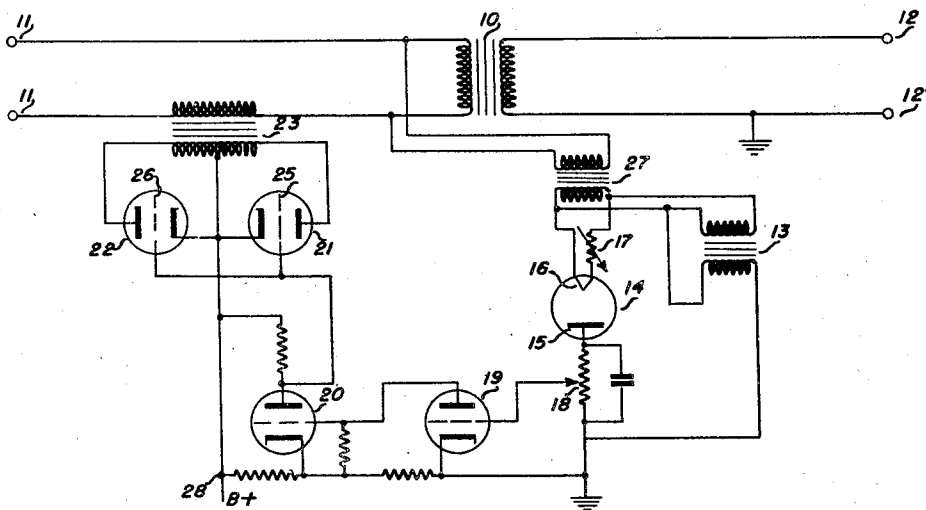
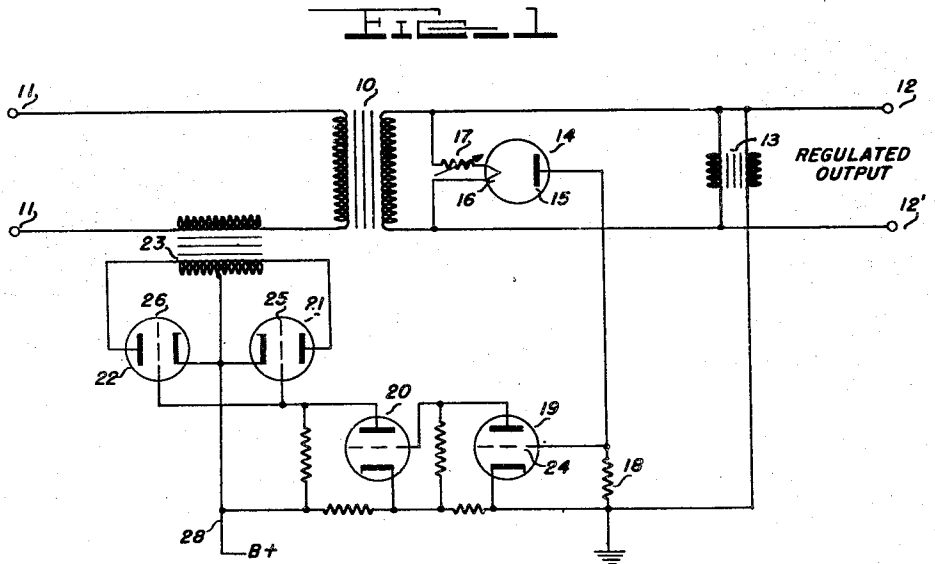

Inventor  
ALLEN H. SCHOOLEY

334

*Stone & Beach*  
Attorney

# UNITED STATES PATENT OFFICE

2,444,472

## VOLTAGE REGULATOR CIRCUIT

Allen H. Schooley, Washington, D. C.

Application June 19, 1943, Serial No. 491,470

1 Claim. (Cl. 323—89)

(Granted under the act of March 3, 1883, as amended April 30, 1928; 370 O. G. 757)

1

This invention relates to a voltage regulator and more particularly to a means for stabilizing the output from a line controlled transformer.

In many of the current radio circuits voltage regulation is of prime importance since minute voltage changes may effect the operating characteristic of the entire circuit. Most voltage regulators provided by the prior art relate to B supply and bias regulation. Filament voltage regulation, however, is also of primary importance since changes in filament voltage will also effect the operating characteristic of the vacuum tubes in the circuits.

It is therefore, an object of this invention to provide a voltage regulator for use in controlling the output of a transformer.

It is another object of this invention to provide a filament voltage regulator.

It is another object of this invention to provide a voltage regulator which is equally responsive at all frequency changes.

Other objects and features of the present invention will become apparent upon a careful consideration of the following detailed description when taken together with the accompanying drawings, the figures of which are designed for the sole purpose of illustration and not as a definition of the limits of the invention, reference being had for the latter to the appended claim.

Fig. 1 is a schematic diagram of a preferred embodiment of the present invention, and

Fig. 2 is a schematic diagram of one modification of the present invention.

It is contemplated by the present invention to provide a means for regulating the output of a transformer by utilizing the change in output voltage to control the exciting current of the transformer, and more particularly to control the impedance in the primary circuit of the transformer. The manner in which I propose to accomplish the foregoing is through the utilization of the output voltage from the transformer as a control means for regulating the thermionic emission of a vacuum tube and consequently the conductivity of the tube, which in turn operates to control a serially connected impedance in the primary circuit of the transformer.

Reference is had more particularly to Fig. 1 wherein there is shown a preferred embodiment of the present invention, comprising a transformer 10 the output voltage of which it is desired to regulate, having a pair of input terminals 11 and 11' and a pair of output terminals 12 and

2

12'. Across this latter pair of terminals there is connected a filamentary heater 16 of the diode 14, which in turn contains a serially connected resistance 17 for use in regulating the heater current. The primary winding of a second transformer 13 is connected in shunt with the heater 16, while one side of the secondary winding thereof is connected to one of the output terminals 12 and the other side through resistance 18 to the plate of diode 14. The latter connection provides the plate of diode 14 with a pulsating positive voltage. As shown in the Fig. 1 the output of diode 14 is fed to the control electrode 24 of the first tube 19 of a pair of serially connected direct coupled amplifiers 19 and 20. Since these amplifiers are direct coupled they are equally responsive at all frequencies. The output of this direct coupled amplifier circuit is fed in parallel to the respective control electrodes 25 and 26 of the tubes 21 and 22. The plates of these last two mentioned tubes are connected in push-pull by way of the secondary winding of transformer 23, the primary winding of which is serially connected to the primary winding of transformer 10. A source of plate potential for the direct coupled amplifier circuit comprising tubes 19 and 20 is supplied at 28.

Normal operation of the circuit is as follows: Resistance 17 is regulated to run heater 16 a little colder than usual i. e. a predetermined amount below rated heater voltage so as to draw a normally fixed plate current and produce the desired voltage drop across resistance 18. This voltage drop provides a source of input to tube 19 and consequently produces the desired bias for the control electrodes 25 and 26 of tubes 21 and 22 by virtue of the amplification of the direct coupled amplifier circuit. The bias on the last mentioned tubes controls the current passage through these tubes and consequently the load on the secondary winding of transformer 23. The load on the secondary of this transformer is reflected to the primary winding thereof to sustain the desired exciting current in transformer 10 and thus maintain a constant voltage drop across the primary winding of the latter in response to the impedance reflected by transformer 23 which in turn is under control of the thermionic emission of the diode heater 16.

I have found that the thermionic emission of diode 14 is very responsive to slight changes in heater voltages especially when the diode heater is operated slightly colder than normal as in the present instance. Thus let it be assumed that for some reason an increase in output volt-

3

age is occasioned, which increases the thermionic emission of heater 16 and thereby increases the voltage drop across resistance 18. This increase in voltage drop appears as a negative bias to the control electrode 24 of tube 19 which causes the plate voltage of this tube to rise and consequently the plate voltage of tube 20 to drop. The drop in plate voltage of tube 20 appears as a negative bias to the control electrodes 25 and 26 of tubes 21 and 22 to decrease the current flow through these tubes which in effect produces a decrease in load on the secondary of transformer 23. The decrease in load of the secondary is reflected into the primary winding of this transformer as a high impedance to reduce the exciting current of transformer 10 and consequently decrease the output voltage thereof. Thus if a decrease in output voltage was occasioned the reverse action of the amplifier circuit and tubes 21 and 22 would result to cause an increase in exciting current to transformer 10 and consequently an increase in output voltage therefrom.

The operation of the circuit shown in Fig. 2 is identical to that circuit shown in Fig. 1, with the exception that this circuit involves the use of an additional transformer 27, and the resistance 18 is made variable in order to regulate the input to the amplifier circuit and hence the magnitude of the bias voltage supplied to tubes 21 and 22. Therefore, further explanation of this circuit is believed to be unnecessary.

Although I have shown and described only certain and specific embodiments of the present invention, I am fully aware of the many modifications possible thereof. Therefore this invention is only to be restricted except insofar as is necessitated by the prior art and the spirit of the appended claim.

The invention described herein may be manu-

4

factured and used by or for the Government of the United States of America for governmental purposes without the payment of any royalties thereon or therefor.

I claim:

A means for regulating the output voltage of a transformer, comprising a thermionic vacuum tube having a filamentary heater and a plate, said heater connected across the output terminals of said transformer in such a manner that its thermal emission varies in accordance with the change in output from said transformer, a resistance means disposed in series with said heater and adjusted to operate said heater at a predetermined value below its rated voltage, an amplifier circuit, means connecting the output of said vacuum tube to the input of said amplifier circuit, a pair of electron discharge devices each having an anode, a cathode and a control electrode, a second transformer having the primary winding thereof connected in series with the input to said first transformer and the secondary winding connecting the anodes of said discharge device in push-pull, and means supplying the output of said amplifier circuit in parallel to the control grids of said discharge devices to thus control the impedance reflected into the primary circuit of said first transformer by said second transformer.

ALLEN H. SCHOOLEY.

#### REFERENCES CITED

The following references are of record in the file of this patent:

#### UNITED STATES PATENTS

Number	Name	Date
1,935,413	Prince	Nov. 14, 1933
2,066,943	Philpott	Jan. 5, 1937