

(19) World Intellectual Property Organization
International Bureau



(43) International Publication Date
7 December 2000 (07.12.2000)

PCT

(10) International Publication Number
WO 00/72907 A1

- (51) International Patent Classification⁷: **A61M 25/00**
- (21) International Application Number: PCT/US00/14269
- (22) International Filing Date: 23 May 2000 (23.05.2000)
- (25) Filing Language: English
- (26) Publication Language: English
- (30) Priority Data:
09/321,973 28 May 1999 (28.05.1999) US
- (71) Applicant: **PRECISION VASCULAR SYSTEMS, INC.**
[US/US]; 360 Wakara Way, Salt Lake City, UT 84108 (US).
- (72) Inventors: **JACOBSEN, Stephen, C.**; 274 South 1200 East, Salt Lake City, UT 84117 (US). **LIPPERT, John, A.**; 9006 North Jeremy Circle, Park City, UT 84098 (US). **DAVIS, Clark, C.**; 4564 Wallace Lane, Salt Lake City, UT 84117 (US).
- (74) Agents: **MCKINNEY, David, R.** et al.; Thorpe, North & Western, L.L.P., P.O. Box 1219, Sandy, UT 84091-1219 (US).
- (81) Designated States (*national*): AE, AL, AM, AT, AU, AZ, BA, BB, BG, BR, BY, CA, CH, CN, CR, CU, CZ, DE, DK, DM, EE, ES, FI, GB, GD, GE, GH, GM, HR, HU, ID, IL, IN, IS, JP, KE, KG, KP, KR, KZ, LC, LK, LR, LS, LT, LU, LV, MD, MG, MK, MN, MW, MX, NO, NZ, PL, PT, RO, RU, SD, SE, SG, SI, SK, SL, TJ, TM, TR, TT, UA, UG, UZ, VN, YU, ZA, ZW.
- (84) Designated States (*regional*): ARIPO patent (GH, GM, KE, LS, MW, MZ, SD, SL, SZ, TZ, UG, ZW), Eurasian patent (AM, AZ, BY, KG, KZ, MD, RU, TJ, TM), European patent (AT, BE, CH, CY, DE, DK, ES, FI, FR, GB, GR, IE, IT, LU, MC, NL, PT, SE), OAPI patent (BF, BJ, CF, CG, CI, CM, GA, GN, GW, ML, MR, NE, SN, TD, TG).

Published:
— With international search report.

For two-letter codes and other abbreviations, refer to the "Guidance Notes on Codes and Abbreviations" appearing at the beginning of each regular issue of the PCT Gazette.

(54) Title: APPARATUS FOR DELIVERING FLUIDS TO BLOOD VESSELS, BODY CAVITIES, AND THE LIKE

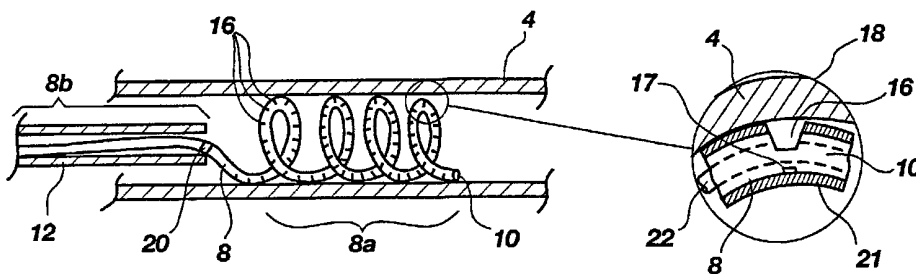

(57) Abstract: An apparatus for delivering fluids to blood vessels, body cavities, and the like, includes a resilient tubular wire (8) for threading lengthwise into the lumen of a catheter (12), out the distal end thereof to a target location of a body passageway to be treated. The tubular wire (8) has a central lumen (10), and a distal end formed into a coil (8a), which, when straightened, may be threaded lengthwise through the catheter (12), but when extended out the distal end of the catheter (12) at the target location, resumes its coiled shape. The tubular wire (8) includes openings (16) at least on the outside of the coils for discharging radially outwardly medication carried in the lumen (10) of the wire (8). In this manner, the medication may be directed toward the wall of the passageway to infuse a diseased area being treated.



WO 00/72907 A1

**APPARATUS FOR DELIVERING FLUIDS TO BLOOD VESSELS,
BODY CAVITIES, AND THE LIKE**

1. Field of the Invention

This invention relates to invasive medical devices for delivering medications and therapeutic agents into blood vessels, body cavities, organs, tumors and the like. More particularly, the present invention relates to devices for concentrating the delivery of such medications and agents to the walls of the blood vessels and cavities.

2. State of the Art

Various vascular diseases involving vessel walls, for example, arterial sclerosis, aneurysm or other weakening of the vessel wall, occlusive lesions, etc., may benefit from the application of medications to the affected area of the vessel wall. This may be done systemically by injecting medication into the vessel and then allowing the blood to carry the medication to the affected area. The problem with this approach is that high dosages of medication are required to ensure that some small portion reaches the affected area, and the high dosage may be harmful to other organs or body parts. This approach is also expensive and not especially effective. Another approach to treating diseases of vessel walls is to place a block before and after the affected area and then inject medications into that portion of the vessel between the two blocks. The problem with this approach is that blood flow is stopped for a certain amount of time and this, in itself, is dangerous; also, it generally cannot be stopped long enough for effective uptake of the medication by the vessel walls.

Another prior art approach is to thread a catheter through the blood vessel to the affected area and then either supply the medication through the catheter to the affected area or supply the medication through a needle which itself is threaded through the catheter, pierce the vessel wall with the needle, and then supply the medication (see U.S. Patent No. 5,354,279).

An additional prior art approach to supplying medication to a vessel wall involves the use of an

inflatable sleeve positioned adjacent the affected area, where the sleeve includes an annular cavity holding the medication. When the sleeve is inflated to expand outwardly, the medication held in the cavity is placed into
5 contact with the vessel walls and released thereinto. The problem with this approach is that the blood vessel again is blocked for a time and thus a gradual therapeutic regimen is not possible. Other approaches to delivering medication to vessel walls are disclosed in U.S. Patent
10 Nos. 5,681,281, 5,364,356, and 5,112,305.

It would therefore be desirable to have a device for delivering medication, therapeutic agents, and the like efficiently and effectively to a blood vessel wall, body cavity wall, etc. which is non-occlusive and substantially
15 non-inhibiting of blood flow. It would also be desirable to have such a device which delivers medication substantially directly to a vessel wall, and may do so for an extended period of time.

20 OBJECTS AND SUMMARY OF THE INVENTION

It is therefore an object of the invention to provide a device for delivering medication, therapeutic agents, and the like efficiently and effectively to a blood vessel wall, body cavity wall, etc.

25 It is also an object of the invention to provide such a device which is non-occlusive and substantially non-inhibiting of blood flow.

It is another object of the invention to provide such a device which may be easily deployed through the vascular system and other body cavities to desired target locations
30 for delivering the medication, therapeutic agents, and the like.

It is also an object of the invention to provide such a device which is capable of delivering medication
35 substantially directly to a vessel or cavity wall.

It is still another object of the invention to provide such a device, in accordance with one aspect thereof, in

which the degree to which blood or other cavity fluid mixes with the medication during administration may be controlled.

The above and other objects are realized in one illustrative embodiment of the invention which includes a resilient tubular wire for threading into a blood vessel or other body passageway to a target wall location which is to be treated with medication or other therapeutic agent. The tubular wire forms a coil at its distal end, and is configured for straightening and threading lengthwise into, through and out the terminal end of a catheter to the target wall location. The wire resumes the coil shape within the blood vessel or body cavity when its distal end exits the terminal end of the catheter. The wire includes a plurality of cuts or openings at least on the outside of the coils for discharging radially outwardly medication carried in the hollow of the wire. Discharge would occur once the coil was in place at the target location by supplying medication through the proximal end of the tubular wire. An occlusive coating formed, for example, by dip coating could be disposed over the wire and openings and then cuts selectively made in the coating to further control discharge of the medication.

In accordance with one aspect of the invention, rather than use a tubular wire, a solid wire could be used, again, having a coil shape at its distal end. A plurality of vesicles would be formed on the outside of the coils for holding fluid or dissolvable solids to be delivered toward the vessel or cavity walls. A sheath or membrane may be disposed over the coil wire to cover the vesicles. Such a membrane may be dissolvable in blood or body cavity fluid to release the contents of the vesicles or the membrane may be made of a permeable material through which the medication could pass.

In accordance with another aspect of the invention, the spacing between adjacent coils may be selectively varied to either increase the mixing of blood or body

cavity fluid with the medication (adjacent coils separated some distance), or decrease the mixing (little or no distance between adjacent coils).

In accordance with yet another aspect of the
5 invention, the coiled portion of the tubular wire may be coated with a soft coating of foam, fuzz, or hydrogel to provide a better seal between adjacent wires in the coil and between the coil and the wall of the body passageway. This coating further reduces mixing of the medication and
10 bodily fluids within the passageway.

BRIEF DESCRIPTION OF THE DRAWINGS

The above and other objects, features and advantages of the invention will become apparent from a consideration
15 of the following detailed description presented in connection with the accompanying drawings in which:

FIG. 1 is a side, partially cross-sectional view of a tubular wire fluid delivery device made in accordance with the principles of the present invention;

20 FIG. 2 is a side, partially cross-sectional view of the device of the present invention shown in place in a blood vessel within a stented vessel or duct;

FIG. 3 is a side, partially cross-sectional view of an hourglass coil configuration of the present invention in
25 which adjacent coils are in contact with one another;

FIG. 4 is a side, partially cross-sectional view of an hourglass coil configuration of the present invention in which adjacent coils are spaced apart;

FIG. 5 is a side, cross-sectional view of a solid-wire
30 embodiment of the present invention; and

FIG. 6 is a side, partially cross-sectional view of a portion of the fluid delivery device of the present invention in which the outer surface of the wire is coated with a thin layer of fuzz, foam, or hydrogel.

35

DETAILED DESCRIPTION OF THE PREFERRED EMBODIMENT

Referring to FIG. 1, there is shown a side, cross-

sectional view the walls of a blood vessel 4 into which has been deployed the coil portion 8a of a tubular wire 8 having a central lumen 10. A non-coil portion 8b of the wire 8 is shown threaded in a catheter 12 which, itself, is shown threaded into the blood vessel 4. The tubular wire shown in FIG. 1 and subsequent figures is round in cross section. However, it will be apparent that tubular wires of other cross sectional shapes may also be used, and because of their different shape and structural properties may provide distinct advantages in certain circumstances. For example, the cross section of the tubular wire 8 may be round, square, hexagonal, octagonal, rectangular, oval, elliptical, or any other desired shape.

The coil portion 8a is initially straightened and inserted lengthwise into the catheter 12 for delivery to the target location in the blood vessel 4, but once the coil portion emerges from the distal end of the catheter, it resumes its coil shape. The threading of catheters into blood vessels and other body cavities, and the threading of wires or other treatment objects through catheters are well known to those skilled in the art.

The coil portion 8a of the tubular wire 8 is formed with a plurality of cuts or openings 16 on the outside of the coils so that at least when the portion 8a is unconstrained to resume the coil shape, the cuts 16 open additionally to allow flow of fluid medications, therapeutic agents, etc from the central lumen 10. Cuts 16 may also be provided on the inside of the coils as well, to help determine the shape and flexibility of the wire 8. (see enlarged section of wire at 18). However, it will be apparent that these inside cuts will preferably not communicate with the central lumen 10 of the wire 8 because any openings on the inside of the coils will tend to provide medication toward the inside of the coil, which is not desired. Otherwise, some or all of the inward cuts should preferably be sealed with an occlusive coating to prevent inward flow of the medication.

The cuts or openings 16, whether on the inside or outside of the coil, may be formed non-uniform in size, shape, or spacing so as to vary the flexibility and stiffness of the wire 8. It will be apparent to those skilled in the art that the shape, size, and spacing of cuts formed on an elongate member will have a direct effect on the ultimate shape, flexibility, and stiffness of the member. For example, widely spaced openings 16 will make the wire 8 less flexible than more closely spaced openings. Similarly, deeper or wider openings 16 will make the wire 8 more flexible. Thus, where a tighter coil is desired, the cuts may be placed closer together, or made deeper or wider, and where it is desired that the coil have a larger diameter, the cuts or openings may be made shallower or at a greater spacing.

It will also be apparent that the geometry of the cuts on the inside of the coil, if any, will preferably vary from that of the cuts or openings on the outside of the coil. As noted above, the cuts on the inside of the coil preferably are not as deep as the cuts on the outside of the coil, and do not communicate with the lumen 10 of the tubular wire. Thus, the spacing, size, and shape, of the cuts or openings may be non-uniform between the outside and inside of the coil, as well as varying along the length of the tubular wire.

Since cuts or openings 16 which communicate with the lumen 10 of the tubular wire are formed on the outside of the coils, when medication is transmitted through the lumen 10 of the tubular wire 8 and out the openings 16, the medication is caused to flow radially outwardly toward the walls of the blood vessel 4. In this manner, medication can be delivered directly toward a diseased portion of the wall of the blood vessel 4 to better infuse the diseased portion with the medication. Of course, if the coil portion 8a has been dimensioned to press outwardly against the walls of the blood vessel 4, any medication emerging from the openings 16 would come in direct contact with the

wall.

Preferably, the tubular wire 8 is made of nickel-titanium alloy, but may also be made of various polymers, stainless steel, composites, or other suitable materials and combinations of these. The cuts or openings 16 are preferably made by saw cutting or grinding (see co-pending U.S. Patent Application, Serial No. 08/714,555, filed September 16, 1996), such as with an abrasive blade, but may also be formed by chemical etching, laser cutting, electro-discharge machining (EDM) or other method suitable for making micro cuts or openings. The preferred saw cutting method uses a micromachining process which allows very accurate longitudinal, depth, width, and angular position control of the cuts on the very fine tubular wire. This method has been found to be superior to other methods in controlling the quality and consistency of cuts, and is also far more economical than other methods, such as EDM.

In use, the catheter 12 is threaded through the blood vessel 4 until the distal end of the catheter reached a target location in the blood vessel to be treated. Then, the tubular wire 8 is threaded through the lumen of the catheter 12 and out the distal end thereof to enable the coil portion 8a to resume the coil shape. The medication may be supplied through the lumen 10 of the tubular wire 8 to exit the cuts or openings 16 and thereby treat the diseased portion of the blood vessel 4.

After delivery of the medication, the tubular wire 8 may then be retracted back through the catheter 12. Alternatively, the tubular wire 8 could include a discontinuity 20 which, when mechanically stressed, would cause severance at the location of the discontinuity. By this means, the substantially linear proximal portion of the tubular wire 8 may be advantageously detached from the distal coiled portion 8a so as to leave it in place in the blood vessel 4 to act as a stent to maintain the blood vessel patency (see co-pending U.S. Patent Application,

Serial No. 09/023,806, filed February 13, 1998).

A polyurethane or similar plastic coating 21 (shown in the enlarged view 18 of FIG. 1) may be applied to selected parts of the coil portion 8a to better control the outflow of medication through the openings 16. For example, if only one side of the vessel wall were to be treated, a polyurethane coating could be applied to all but those portions of the coils which were to be in contact or adjacent to the side of the blood vessel wall to be treated. The coating 21 will block the exit of medication from the openings 16 which are covered, while allowing the exit of medication through openings that are not covered. Alternatively, the entire coil portion 8a could be covered with a plastic coating (for example, by dip coating), and then cuts made selectively in the coating, to allow discharge of medication from the tubular wire 8 only from selected locations along the tubular wire.

Another approach to controlling release of medication through the openings 16 in the tubular wire 8 would be to include in the lumen 10 of the tubular wire 8 an inner liner 22 (shown in the enlarged view 18 of FIG. 1) which itself has very small perforations (or porosity) selectively positioned along its length to control the medication discharge, for example, to provide more uniform distribution of medication discharge along the coil portion 8a. The liner material might illustratively be polysulfone.

FIG. 2 shows a side, partially cross-sectional view of a blood vessel 24 in which is disposed a regular stent 26 for holding the blood vessel or duct open. Shown disposed within the regular stent 26 is the coil portion of a tubular wire 28 through which medication is to be delivered to the walls of the blood vessel 24. Note that the coils of the coil portion of the tubular wire 28 are in intimate contact with one another so that medication released toward the walls of the blood vessel 24 cannot be greatly diluted by blood flowing through the coil interior of the tubular

wire. Rather, the tight coil configuration of the tubular wire 28 tends to hold the medication between the exterior of the coil and the vessel walls to better medicate the target locations of the blood vessel being treated. The presence of the regular stent 26 may also inhibit the flow of blood adjacent to the blood vessel walls and this further inhibits dilution of the medication.

FIG. 3 is a side, partially cross-sectional view of a blood vessel 34 in which is disposed the coil portion of a tubular wire 38, with the coil portion having an hourglass shape as shown. The coils located at the ends of the coil portion have a greater diameter and are in contact with the walls of the blood vessel 34 while the coils located centrally are smaller in diameter and are out of contact with the walls, to define an annular space 40 between the coils of the tubular wire 38 and the walls of the blood vessel. The medication is released into this annular space 40 to contact the walls of the blood vessel 34, with little interference from blood flowing in the blood vessel. In particular, the combination of adjacent coils of the tubular wire 38 being in contact with one another and the end most coils of the coil portion contacting the walls of the blood vessel 34, work to stagnate fluid located in the annular space 40 so that medication released into the space is not washed away.

FIG. 4 shows a similar hourglass configuration of the coil portion of a tubular wire 48 (as in FIG. 3), but here the adjacent coils are spaced apart so that the annular space 50 is less isolated and protected from the flow of blood in the blood vessel 44. In this configuration, of course, more blood would mix with the medication and dilute it. By controlling the spacing between adjacent coils of the coil portion of the tubular wire 48, the amount of mixing of the released medication and blood can be controlled.

FIG. 5 shows an alternative embodiment, in cross-sectional view, of a solid wire 54 delivery device, shown

disposed against a vessel or cavity wall 58. Formed on the side of the wire 54 adjacent the wall 58 are a plurality of vesicles or cavities 62 in which fluid medication, pellets, capsules, or similar medicaments are disposed. By
5 positioning the wire 54 tightly against the wall 58, the medication in the vesicle 62 migrates therefrom to the vessel wall.

Advantageously, a membrane or sheath 64 is disposed about the wire 54 (formed, for example, by dip coating) to
10 hold the medication in place in the vesicles 62 until the wire is deployed to the desired target location. The sheath 64 may be made of a blood dissolvable material such as polyvinyl alcohol or a permeable material such as polysulfone, to allow the discharge of the medication from
15 the vesicles either upon dissolution of the sheath or through the sheath, as the case may be.

Shown in FIG. 6 is yet another alternative embodiment of the fluid delivery device of the present invention. FIG. 6 provides a side, partially cross-sectional view of a
20 portion of the coil section 8a of the tubular wire 8 disposed against the inner surface of a blood vessel wall 4. In this embodiment, the wire 8 having lumen 10 is advantageously coated on its outside with a thin coating 70 of fuzz, foam, or hydrogel to help prevent mixing of blood
25 or other bodily fluids with the therapeutic fluid being delivered. This layer 70 of soft fuzz, foam, or hydrogel provides an improved seal between adjacent coils, and between the coils and the vessel wall 4. With this
30 embodiment, the therapeutic fluid may be more completely isolated from the surrounding bodily fluids, and prevented from mixing therewith, thus improving the efficacy of treatment and reducing the required dosage. It will be apparent that this coating 70 may be included with several
35 of the previous embodiments of the invention as described above.

It is to be understood that the above-described arrangements are only illustrative of the application of

the principles of the present invention. Numerous
modifications and alternative arrangements may be devised
by those skilled in the art without departing from the
spirit and scope of the present invention and the appended
5 claims are intended to cover such modifications and
arrangements.

CLAIMS

What is claimed is:

1. An apparatus for delivering medication to a wall of a body cavity, said apparatus comprising:

5 a resilient tubular wire having a central hollow, at least a portion of said wire being resiliently formed into a coil having an outside surface, said tubular wire being configured to be straightened for threading lengthwise through a catheter, and to resume its coiled shape when
10 extended beyond the distal end of the catheter to a target location; and

said wire including a plurality of openings formed at least on the outside of the coil, at least some
15 of said openings communicating between the outer surface and the central hollow of said tubular wire for discharging radially outwardly medication carried in the central hollow of the wire, to thereby direct medication toward the
20 wall of the cavity.

2. An apparatus as in Claim 1 wherein the coiled portion of said tubular wire comprises the distal end thereof, and said tubular wire further comprises a proximal
25 portion which is generally linear.

3. An apparatus as in Claim 2 wherein said tubular wire includes means for detaching the distal coil portion of the wire from the proximal portion of the wire.
30

4. An apparatus as in Claim 1 wherein the coil formed by the tubular wire is dimensioned to contact the cavity wall around the circumference thereof.

35 5. An apparatus as in Claim 1 wherein the coil formed by the tubular wire is dimensioned to have a diameter approximately equal to the inner diameter of the cavity at

the target location.

6. An apparatus as in Claim 1 further including an occlusive coating disposed over selected openings of the tubular wire to prevent the exit of medication therethrough.

7. An apparatus as in Claim 1 further including an occlusive coating disposed over the tubular wire, with openings selectively formed in the coating, to control the exit of medication from the tubular wire.

8. An apparatus as in Claim 7 wherein said coating is a polymeric material formed by dip-coating.

9. An apparatus as in Claim 1, further including an inner liner disposed in the hollow of the tubular wire, said liner including a plurality of perforations selectively positioned to control exit of medication from the tubular wire through said openings.

10. An apparatus as in Claim 1 wherein the tubular wire is formed such that adjacent coils do not contact one another.

11. An apparatus as in claim 1 wherein the tubular wire is formed such that adjacent coils contact one another.

12. An apparatus as in Claim 1 wherein the coil includes a section in which the end portions of the section have a greater diameter than the central portion.

13. An apparatus as in Claim 12 wherein at least one coil in the central portion of said section has a smaller diameter than the coils at the end portions thereof.

14. An apparatus as in Claim 12 wherein at least one coil at each end of said section has a larger diameter than the coils in the central portion thereof.

5 15. An apparatus as in Claim 1 further including a coil stent disposed at the target location to support the cavity walls, said tubular wire coil being formed for disposition within the coil stent to deliver the medication to the cavity walls therein.

10

16. An apparatus as in Claim 1 further comprising a coating disposed upon the coiled portion of the tubular wire so as to improve the seal between adjacent wires of the coil and between the coil and the wall of the body cavity, so as to discourage the mixing of the medication with bodily fluids in the cavity.

15

17. An apparatus as in Claim 16 wherein said coating material is selected from the group comprising fuzz, foam, and hydrogel.

20

18. An apparatus as in Claim 1 wherein said openings are non-uniform in size, shape, or spacing so as to vary the flexibility and stiffness of said wire.

25

19. An apparatus as in Claim 1 wherein said openings are formed by micromachining.

20. An apparatus as in Claim 19 wherein said openings are formed by saw cutting the surface of said tubular wire.

30

21. An apparatus as in Claim 1 wherein the cross sectional shape of said tubular wire is selected from the group comprising round, square, hexagonal, octagonal, rectangular, oval, and elliptical.

35

22. The apparatus as in Claim 1, further comprising a

plurality of cuts formed on the inside of said coil.

23. An apparatus as in Claim 22 wherein said cuts and said openings are non-uniform in size, shape, or spacing so as to vary the flexibility and stiffness of said wire.

24. The apparatus of Claim 22 wherein said cuts are formed by micromachining.

25. The apparatus of Claim 24 wherein said cuts are formed by saw cutting the surface of said tubular wire.

26. The apparatus of Claim 22 wherein at least some of said cuts formed on the inside of the coil extend from the outside surface of the tubular wire to the inside thereof.

27. The apparatus of Claim 26, further comprising an occlusive coating disposed over at least some of the cuts on the inside of the coil to prevent the exit of medication therethrough.

28. A device for delivering medication toward the walls of a blood vessel, said device comprising:
an elongate resilient tubular wire having a central lumen, the distal portion of said wire being resiliently formed into a coil having an outside surface, said wire being configured to be straightened for threading lengthwise through a catheter, and to resume its coiled shape when extended beyond the distal end of the catheter to a treatment location in the blood vessel;
said wire including a plurality of vesicles formed on the outside surface of the coil for holding fluids or solids to be delivered toward the vessel walls at the treatment location.

29. A device as in Claim 28, further including a sheath disposed over the coil to cover the vesicles.

5 30. A device as in Claim 29 wherein the sheath is made of a material which is dissolvable in blood.

31. A device as in Claim 29 wherein the sheath is made of a permeable material, through which the fluids or solids may pass.

10

32. A device as in Claim 28, further comprising a coating disposed upon the coiled portion of the tubular wire so as to improve the seal between adjacent wires of the coil and between the coil and the wall of the blood vessel, so as to discourage the mixing of the fluids or solids with bodily fluids in the blood vessel.

15

33. A device as in Claim 32 wherein said coating material is selected from the group comprising fuzz, foam, and hydrogel.

20

34. A device as in Claim 28 wherein the coil formed by the tubular wire is dimensioned to have a diameter approximately equal to the inner diameter of the blood vessel at the treatment location.

25

35. A device as in Claim 28 wherein the coil includes a section in which the end portions of the section have a diameter dimensioned to contact the inside surface of the blood vessel, and the central portion of the section has a diameter which is less than the inner diameter of the blood vessel.

30

36. A device as in Claim 28 wherein the cross sectional shape of said tubular wire is selected from the group comprising round, square, hexagonal, octagonal, rectangular, oval, and elliptical.

35

37. An apparatus for delivering medication to a wall of a blood vessel, said apparatus comprising:

5 a resilient tubular wire having a central hollow, at least a portion of said wire being resiliently formed into a coil having an outside surface, said tubular wire being configured to be
10 straightened for threading lengthwise through a catheter, and to resume its coiled shape when extended beyond the distal end of the catheter to a target location in the blood vessel; and
15 said wire including a plurality of openings formed by micromachining at least on the outside of the coil, said openings communicating between the outer surface and the central hollow of said tubular wire for discharging radially outwardly medication carried in the central hollow of the wire, to thereby direct medication toward the wall of the vessel.

20 38. An apparatus as in Claim 37 wherein said openings are formed by saw cutting the surface of said tubular wire.

25 39. A device as in Claim 37 wherein the cross sectional shape of said tubular wire is selected from the group comprising round, square, hexagonal, octagonal, rectangular, oval, and elliptical.

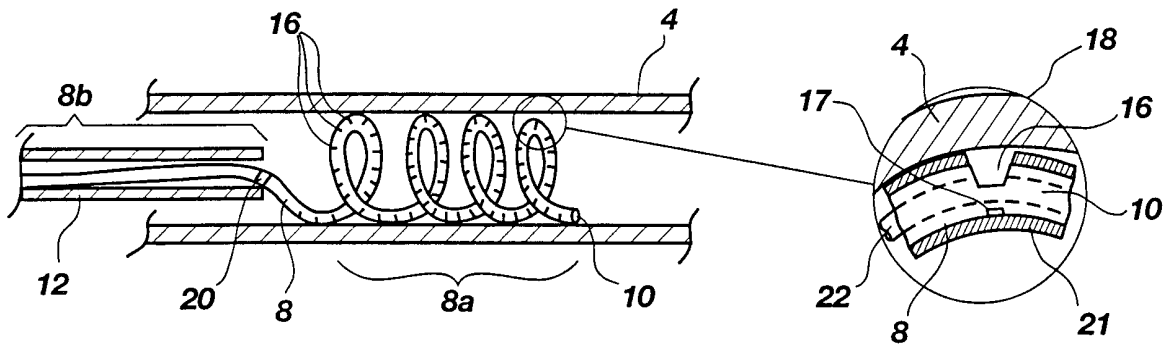

Fig. 1

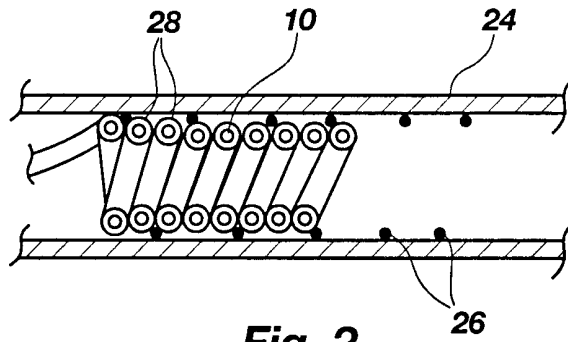

Fig. 2

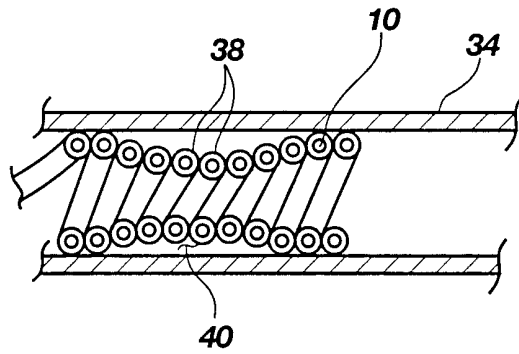

Fig. 3

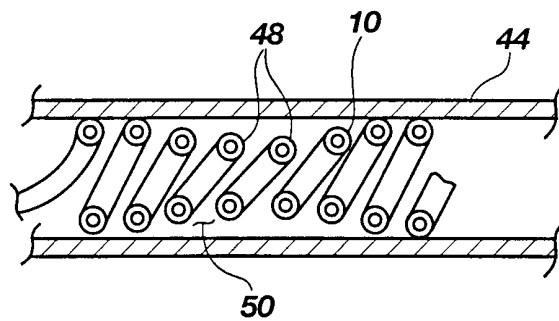

Fig. 4

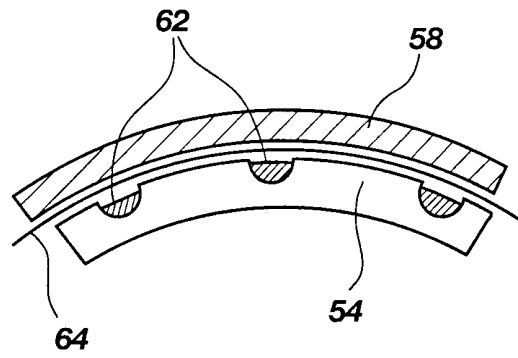

Fig. 5

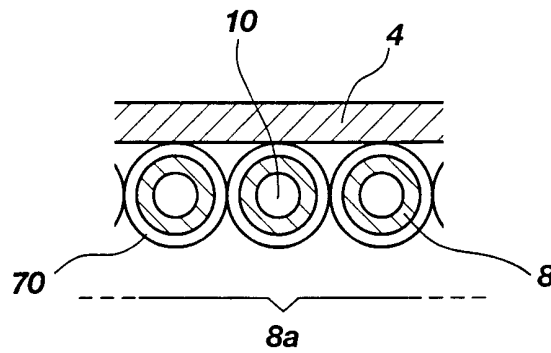

Fig. 6

INTERNATIONAL SEARCH REPORT

International application No.
PCT/US00/14269

A. CLASSIFICATION OF SUBJECT MATTER

IPC(7) :A61M 25/00
US CL :604/530

According to International Patent Classification (IPC) or to both national classification and IPC

B. FIELDS SEARCHED

Minimum documentation searched (classification system followed by classification symbols)

U.S. : 604/264, 507, 523, 526, 530

Documentation searched other than minimum documentation to the extent that such documents are included in the fields searched
WEBSTERS DICTIONARY

Electronic data base consulted during the international search (name of data base and, where practicable, search terms used)

EAST
Search Terms: coil, aperature, catheter

C. DOCUMENTS CONSIDERED TO BE RELEVANT

Category*	Citation of document, with indication, where appropriate, of the relevant passages	Relevant to claim No.
Y, P	US 6,053,900 A (BROWN et al.) 25 April 2000, entire patent.	1-39
Y	US 5,873,865 A (HORZEWSKI et al.) 23 February 1999, entire patent.	1-39
Y	US 5,709,874 A (HANSON et al.) 20 January 1998, entire patent.	1-39
Y	US 4,935,004 A (CRUZ) 19 June 1990, entire patent.	1-39
A	US 4,950,258 A (KAWAI et al.) 21 August 1990, entire patent.	1-39

Further documents are listed in the continuation of Box C. See patent family annex.

* Special categories of cited documents:	"T" later document published after the international filing date or priority date and not in conflict with the application but cited to understand the principle or theory underlying the invention
"A" document defining the general state of the art which is not considered to be of particular relevance	"X" document of particular relevance; the claimed invention cannot be considered novel or cannot be considered to involve an inventive step when the document is taken alone
"E" earlier document published on or after the international filing date	"Y" document of particular relevance; the claimed invention cannot be considered to involve an inventive step when the document is combined with one or more other such documents, such combination being obvious to a person skilled in the art
"L" document which may throw doubts on priority claim(s) or which is cited to establish the publication date of another citation or other special reason (as specified)	"&" document member of the same patent family
"O" document referring to an oral disclosure, use, exhibition or other means	
"P" document published prior to the international filing date but later than the priority date claimed	

Date of the actual completion of the international search

14 AUGUST 2000

Date of mailing of the international search report

05 SEP 2000

Name and mailing address of the ISA/US
Commissioner of Patents and Trademarks
Box PCT
Washington, D.C. 20231

Facsimile No. (703) 305-3230

Authorized officer

MICHAEL M THOMPSON

Telephone No. (703) 305-1619