

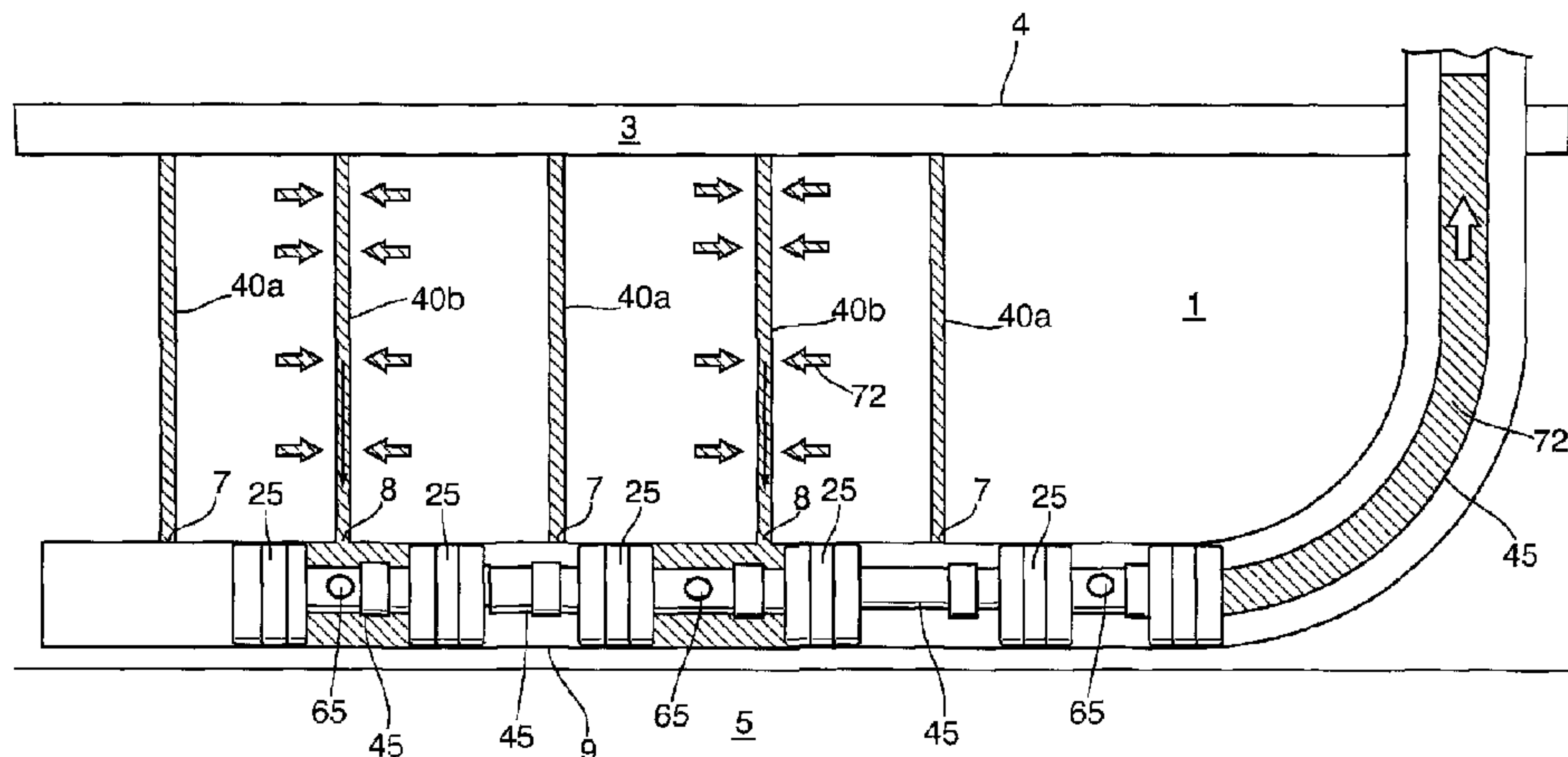

(22) Date de dépôt/Filing Date: 2016/02/05
(41) Mise à la disp. pub./Open to Public Insp.: 2016/04/06
(45) Date de délivrance/Issue Date: 2018/10/02
(62) Demande originale/Original Application: 2 920 201

(51) Cl.Int./Int.Cl. *E21B 43/18* (2006.01),
E21B 33/124 (2006.01), *E21B 43/26* (2006.01),
E21B 43/30 (2006.01)
(72) Inventeur/Inventor:
AYASSE, CONRAD, CA
(73) Propriétaire/Owner:
IOR CANADA LTD., CA
(74) Agent: GOWLING WLG (CANADA) LLP

(54) Titre : METHODE DE BALAYAGE ET RECUPERATION PROGRESSIVE DE PETROLE D'UNE FORMATION SOUTERRAINE
(54) Title: METHOD TO PROGRESIVELY SWEEP AND RECOVER OIL FROM AN UNDERGROUND FORMATION



(57) **Abrégé/Abstract:**

A pressure-up blow-down method for recovering oil from an underground hydrocarbon formation, comprising the steps of: injecting an injection fluid into alternately-spaced multiple -induced fractures which extend radially outwardly and along a horizontal portion of a wellbore in the formation; ceasing injection of said injection fluid; recovering to surface oil which flows from remaining of the multiple induced fractures into the wellbore; and successively repeating the foregoing steps one or more times. Gas preferentially is initially used as the injection fluid and after one successive iteration water is then used. A sliding sleeve or sleeves which may be selectively slid open and closed within the wellbore in accordance with the method to allow and prevent, at various time periods in the method, fluid communication with fluid injection fractures and oil production fractures.

ABSTRACT

A pressure-up blow-down method for recovering oil from an underground hydrocarbon formation, comprising the steps of: injecting an injection fluid into alternately-spaced multiple –induced fractures which extend radially outwardly and along
5 a horizontal portion of a wellbore in the formation; ceasing injection of said injection fluid; recovering to surface oil which flows from remaining of the multiple induced fractures into the wellbore; and successively repeating the foregoing steps one or more times. Gas preferentially is initially used as the injection fluid and after one successive iteration water is then used. A sliding sleeve or sleeves which may be selectively slid open and closed within
10 the wellbore in accordance with the method to allow and prevent, at various time periods in the method, fluid communication with fluid injection fractures and oil production fractures.

METHOD TO PROGRESIVELY SWEEP AND RECOVER OIL FROM AN UNDERGROUND FORMATION

FIELD OF THE INVENTION

The present invention relates to a fluid-drive hydrocarbon recovery process, and more particularly to an fluid drive recovery process which uses fluid injection intermittently and in alternating fractures that have been created in a subterranean hydrocarbon formation, to drive oil in the formation to the remaining adjacent alternating fractures, for subsequent collection from such oil producing fractures and production to surface.

BACKGROUND OF THE INVENTION

Commonly assigned Canadian Patent 2, 855,417 published January 4, 2015 and WO 2016/000068 A1 (corresponding to CA 2,885,146 published January 2, 2016) teach various procedures to exploit induced fractures in multi-fractured horizontal wells, used for, but not limited to, the improved production of oil from tight reservoirs or any consolidated reservoir matrix.

CA '417 and '146 teach the utilization of the fractures as injection or production conduits attached to a horizontal well so that injection fluids can be selectively distributed in a continuous manner to alternate fractures with the remaining fractures employed as production fractures. By eliminating communication between injection and production fractures within the horizontal wellbore, injected fluids are forced to flow through the reservoir matrix from the injection fractures to the production fractures.

One embodiment taught in the above publications teaches the use of a long tubing from the surface running through an isolation actuatable packer placed between the two fractures nearest the toe of the horizontal well. Injectant, which could be but is not limited to water, hydrocarbon gas, CO₂ or mixtures thereof, is conveyed continuously down the long tubing and enters the fracture furthestmost from the heel of the horizontal well (i.e. at the toe

thereof) and penetrates the formation matrix pushing oil towards the adjacent fracture in the direction of the heel and thence into the annulus of the horizontal well, whence it is conveyed to the surface. Once the injectant appears at the surface in sufficient quantity, the packer is deactuated and is moved one fracture closer to the heel of the horizontal well where it is
 5 actuated and continuous injection is resumed. The process continues until the entire reservoir volume delineated by the fractures has been flooded with the injectant. This process has modest cost, but suffers from only a single segment of the reservoir being flooded at one time.

CA 417' and '146 also teach the use of dual-channel tubing or pipe placed in the well liner and having independent flow areas, for example a single tubing or pipe with an internal
 10 divider that that creates independent internal channels or a concentric tubing or pipe having a central channel and an annular channel. The tubing or pipe contain apertures proximate each fracture and an isolation packer around the tubing or pipe between each fracture to prevent communication between the channels within the wellbore. In a continuous process, injectant is conveyed into approximately alternate fractures and oil produced from the other fractures.
 15 Being continuous, this process produces higher oil rates, but also has higher capital costs because of the need for specialized tubing or pipe.

Given the current extremely low oil price (<\$30/bbl) and the high cost of drilling and multi-fracturing long and deep horizontal wells (approximately \$8-million/well) there is a need for a process with low capital cost that can revive existing multi-fractured wells. The
 20 rapid decline rate in tight light oil reservoirs such as the Bakken and Eagle Ford wells can be 70% in the first year and 50% in the second year, however, given sufficient secondary oil recovery, companies could cease drilling new wells without a fall in overall oil production. These existing wells are largely past their 2-year primary recovery prime, however 90-95 % of the original oil-in-place is still there.

25 Other than Fracture Floodingtm, as described in the above-referenced documents, the prospects for secondary oil recovery in light tight oil reservoirs are bleak. Some operators have attempted water flooding or gas flooding from parallel multi-fractured wells, however, communication between fractures short-circuits the flow patterns, undermining reservoir

sweep efficiency. Re-fracturing is expensive and has provided inconsistent results. The process of the present invention holds promise to solve all the major economic and engineering problems concerning secondary oil recovery from light tight oil reservoirs: low capital cost, higher and sustained oil production rates and higher oil recovery factor.

5 **SUMMARY OF THE INVENTION**

The method of the present invention *inter alia* differs from the prior art in that it is an intermittent process that entails periodic re-pressurizing of the reservoir to rejuvenate recovery rates, using fluid injection in alternately-spaced fluid injection fractures, with oil production occurring from remaining alternate (and immediately adjacent) oil production fractures, thereby in such manner most directly applying a fluid drive to the formation to sweep the formation of oil and direct it to the adjacent alternately spaced oil production fractures. Such process is herein referred to as the Fracture Flooding INTtm process or Intermittent Fracture Flooding.

15 Many of existing multi-fractured (i.e. already completed) wells are lined and cemented, and have sliding sleeves already located in the wellbore liner to be able to isolate each fracture.

The present process, where used on an existing well, allows advantage to be taken of this existing equipment, and no other equipment is needed downhole. Accordingly, the method of the present invention may be utilized for a well that has been freshly drilled and completed, or alternatively can be used on a well that is many years into oil production.

20 In the method of the present invention, for new wells, sliding sleeves may be provided at locations along the wellbore where the wellbore is in communication with oil production fractures, to allow such sleeves to isolate/shut in such oil production fractures during a fluid-injection phase of the present method.

In an optional step, where a single conduit/wellbore is used to both inject fluid and produce oil from the wellbore, an additional step may be added to the method whereby the wellbore may be first flushed with injectant prior to the injectant phase, to thereby produce any remaining oil in the wellbore to surface so that such residual oil will not otherwise later enter the reservoir during the fluid injection phase and detrimentally affect relative permeability of the injectant, to say nothing of the loss of the opportunity to recover such residual oil to surface.

As an initial step/phase in the method, fluid injectants are conveyed into an open wellbore liner and enter alternately-spaced open fractures (the fluid injection fractures) where such fluid serves to pressurize the formation and drive oil laterally away from such fluid injection fractures towards adjacent juxtaposed oil production fractures. After a short period, due to such fluid injection which might last a few months, the reservoir will become uniformly re-pressured to the native reservoir pressure or higher. Thereafter, the fluid injection fracture sleeves may be closed, while the remaining sleeves opposite the oil production fractures are then opened. Fluids draining into the wellbore from the oil production fractures are then conveyed to the surface. The oil production period is substantially longer than the injection period, lasting up to 2-years or longer. This completes the first stage of the Intermittent Fracture Flooding process.

Successive iterations/stages of the method of the present invention may be conducted as desired, but preferably, after the initial iteration of the above method, the wellbore is flushed of oil by briefly producing the injectant fractures to the surface, prior to recommencing injectant injection.

The present process therefore differs significantly from the traditional Cyclic or 'Huff and Puff' or Pressure-up-Blow-down processes wherein the near-well region becomes alternately saturated with oil and injectant, and during the injection stage oil is pushed away from the wellbore.

Conversely and by way of contrast, injectant enters the matrix/formation through a dedicated channel – namely the fluid injection fractures, and oil is preferentially produced through separate dedicated channels- namely the oil production fractures (albeit the oil may be produced to surface through the same wellbore as the fluid is injected but this is not detrimental to the reservoir mechanics). In such manner the detrimental effect on fluid injectivity and productivity of the formation caused by decreased oil and water relative permeability when multiple phases are mixed in the reservoir matrix is thereby eliminated.

The method of the present invention and such above particular advantages are thus particularly preferred in tight rocks where its advantages as described herein over the aforesaid methods are particularly acute.

Accordingly, in order to realize the above advantages and achieve some of the advantages over the above methods, in a first broad embodiment of the method of the present invention such method relates to a method for recovering oil from an underground hydrocarbon formation having a lined wellbore therein, said hydrocarbon formation having multiple induced fractures spaced along a portion of a length of said lined wellbore and extending radially outwardly therefrom, by intermittently injecting fluid into alternately-spaced of said fractures and producing hydrocarbons including oil from remaining of said multiple induced fractures, comprising the steps of :

- (i) injecting an injection fluid into said alternately-spaced of said multiple – induced fractures and continuing to do so for a period of time to thereby pressure-up the formation ;
- (ii) ceasing injection of said injection fluid;
- (iii) recovering to surface oil which flows from said remaining of said multiple induced fractures into said lined wellbore at locations of contact of said remaining of said multiple induced fractures with said lined wellbore ; and

(iv) successively additionally repeating the foregoing steps one or more times.

The above method is typically repeated until recovery of said oil in step (iii) ultimately drops below acceptable production rates and quantities.

5 The portion of the length of the wellbore in the methods disclosed herein may be vertical, slant or horizontal, but preferred embodiments the aforesaid portion of the length of the wellbore is substantially horizontal.

10 In a refinement of such above method, the method comprises the further step of flushing oil remaining in the lined wellbore from the lined wellbore, wherein said flushing of said oil is accomplished by briefly producing said injected fluid to surface prior to injecting said injection fluid into the alternately spaced fluid injection fractures in step (i).

15 Specifically, such above method may further be modified by adding after step (vi) but prior to injecting fluid into said alternating multiple induced fractures [i.e. fluid injection fractures) in step (i)], the step of flushing oil remaining in the lined wellbore from the lined wellbore by draining injection fluid remaining in said fluid injection fractures back into said wellbore, and briefly producing said injection fluid and any remaining oil in said wellbore to surface.

20 Alternatively, such method may comprise the further step of flushing oil remaining in said lined wellbore by injecting the injection fluid at a toe of the horizontal portion of the wellbore via a tubing in said lined wellbore extending to said toe thereof, and producing same to surface.

For purposes of nomenclature, alternately-spaced multiple induced fractures along the portion of the length of the wellbore that are injected with fluid are referred to as fluid injection fractures.

Similarly, remaining (alternately spaced) multiple induced fractures from which oil flows into the lined wellbore at locations of contact of such multiple induced fractures and said lined wellbore are hereinafter referred to as oil production fractures.

5 In a further refinement of the above method, a sliding sleeve or sliding sleeves may be provided at the location of contact of the oil production fractures and the lined wellbore to at different times allow and prevent fluid communication of the oil production fractures with the lined wellbore. Accordingly, in such further refinement the present invention, the method comprises an intermittent pressure-up, blow-down method to recover oil from an underground hydrocarbon formation, said hydrocarbon formation having multiple induced
10 fractures spaced along and contacting a portion of a length of a lined wellbore situated in said hydrocarbon formation, said multiple induced fractures extending substantially radially outwardly from said lined wellbore, comprising the steps of:

- 15 (i) closing, via a sliding sleeve or sleeves, alternately-spaced of said multiple induced fractures at locations of contact thereof with said lined wellbore to form a plurality of oil production fractures in the formation which are shut-in from said lined wellbore;
- (ii) injecting an injection fluid into the lined wellbore and causing said injection fluid to flow into remaining of said multiple induced fractures, for a period of time to thereby pressure-up the formation ;
- 20 (iii) subsequently opening said sliding sleeve or sleeves at locations of fluid communication of said oil production fractures with said lined wellbore and allowing fluid communication between said oil production fractures and an interior of said lined wellbore;

- (iv) recovering to surface, and for a period of time, oil which flows into said lined wellbore at locations of contact of said lined wellbore with said oil production fractures; and
- (v) successively repeating each of steps (i)-(iv) one or more times.

5 Again, such above method is typically repeated until recovery of said oil in step (iv) ultimately drops below acceptable production rates and quantities.

 Again, in preferred embodiments, the portion of the length of the lined wellbore in the above method is substantially horizontal.

10 In a preferred embodiment of the above refinement of the method of the present invention, a further step is included, namely the further step, of flushing oil remaining in said lined wellbore from the lined wellbore, wherein said flushing of said oil is accomplished by briefly producing said injected fluid to surface prior to injecting fluid into fluid injection fractures in step (ii).

15 Specifically, such above method may further be modified by adding, after step (v) but prior to injecting said injection fluid in step (ii), the step of flushing oil remaining in the lined wellbore from the lined wellbore by draining injection fluid remaining in said fluid injection fractures back into said wellbore, and briefly producing said injection fluid and any remaining oil in said wellbore to surface.

20 Alternatively, such above method may comprise the further step, after step (v) but prior to again injecting said injection fluid in step (ii), of flushing oil remaining in said lined wellbore by injecting the injection fluid at a toe of the horizontal portion of the wellbore via a tubing in said lined wellbore extending to said toe thereof, and producing same to surface, to thereby avoid such residual oil otherwise being inadvertently (an undesirably) entrained in the injected fluid and re-injected into the formation .

In a further refinement of the method of the present invention, a sliding sleeve or sleeves may be provided at the location of contact of both the fluid production fractures and the oil production fractures with the lined wellbore, and such sleeve or sleeves operated in the following manner.

Specifically, in a further refinement of the method of the present invention, such method comprises an intermittent pressure-up, blow-down method to recover oil from an underground hydrocarbon formation having a lined wellbore and having multiple induced fractures extending radially outwardly from said lined wellbore and longitudinally spaced along a portion of a length of said wellbore, comprising the steps of :

- (i) closing, via a sliding sleeve or sleeves, alternately-spaced of said multiple induced fractures at locations of contact thereof with said lined wellbore to form a plurality of oil production fractures which are shut-in from said lined wellbore;
- (ii) opening, via a sliding sleeve or sleeves, remaining of said multiple induced fractures, at locations of contact thereof with said lined wellbore to form a plurality of fluid injection fractures;
- (iii) injecting an injection fluid into the lined wellbore and causing said injection fluid to flow into said remaining of said multiple induced fractures, for a period of time, to thereby pressure-up the formation ;
- (iv) closing said sliding sleeve or sleeves wellbore at locations of contact of said fluid injection fractures with said lined wellbore, and preventing fluid communication between said fluid injection fractures and an interior of said lined wellbore;

- (v) opening said sliding sleeve or sleeves at locations of contact of said oil production fractures with said lined wellbore, and allowing fluid communication between said oil production fractures and an interior of said lined wellbore;
- 5 (vi) recovering to surface, and for a period of time, oil which flows into said lined wellbore at locations of contact of said lined wellbore with said oil production fractures; and
- (vii) successively repeating each of steps (i)-(v) one or more times.

Again, such above method is typically repeated until recovery of said oil in step (vi) ultimately drops below acceptable production rates and quantities.

10

Again, in preferred embodiments, the portion of the length of the lined wellbore in accordance with the above method is horizontal.

In a refinement of such above method, such method comprises the further step of flushing oil remaining in said lined wellbore from the lined wellbore, wherein said flushing of said oil is accomplished by briefly producing said injected fluid to surface after shutting in the oil production fracture in step (i) and prior to shutting in the fluid injection fractures in step (iv) above.

15

Specifically, such above method may further be modified by adding a step, after step (vi) but prior to shutting in the fluid injection fractures in step (iv), of flushing oil remaining in the lined wellbore from the lined wellbore by draining injection fluid remaining in said fluid injection fractures back into said wellbore and briefly producing said injection fluid and any remaining oil in said wellbore to surface.

20

Alternatively, such above method may comprise the further step after step (vi) of flushing oil remaining in said lined wellbore by injecting the injection fluid at a toe of the horizontal portion of the wellbore via a tubing in said lined wellbore extending to said toe thereof, and briefly producing same to surface.

5 The purpose of the injected fluid in the method of the present invention is as a driving/sweeping fluid to drive oil and hydrocarbons within the formation to the alternately-spaced oil production fractures and thence into the lined wellbore for recovery to surface. It is not necessary that the injected fluid be miscible in oil, but having the injected fluid miscible in oil will advantageously reduce the viscosity thereof and increase the flowability
10 thereof, thereby increasing oil recovery rates from the formation albeit at the slight increased expense of using a fluid miscible in oil, which fluids include, but are not limited to, fluids such as naphtha, diesel, gases which are extracted from oil produced by the present method, carbon dioxide, and other diluents or solvents.

Where a sliding sleeve or sleeves are utilized to open and close the oil production
15 fractures and/or the fluid injection fractures along the wellbore, the step of opening (or closing) the sliding sleeve or sleeves may be carried out by a number of methods, such as:

- (i) using an actuation tool inserted on the end of coil tubing and actuated via pressure supplied to the tool via the coil tubing;
- (ii) using existing fluid-actuated sleeves which have a piston which when
20 pressurized fluid is supplied to the sleeve the piston forces the sleeve to move;
or
- (iii) using ball-actuated sleeves, such as those commercially sold by Packers Plus of Calgary, Alberta, Canada and others as are known in the art, may be used to open or close the sliding sleeves.

As regards ball-actuated sleeves, as described for example in Canadian Patent 2,412,072 a ball may be pumped down the wellbore using injection fluid pressure, which ball engages and slides a respective sleeve to an new (open or closed) position and thereafter disengages therefrom and thereafter progresses down-wellbore to similarly open/close
5 additional downhole sleeves. The ball may be dissolved and the sleeves closed by withdrawing the pumped fluid, with or without the ball, from the wellbore. Thereafter, to successively then re-close (or re-open) the selected sleeves, such may be carried out by insertion in wellbore of an actuation tool at the distal end of coil tubing. The actuation tool is typically inserted to the distal end (toe) of the wellbore. Upon actuation of the actuator tool at the end of the coil tubing
10 typically by supply of a pressurized fluid to the coil tubing and the tool at the end of the coil tubing, the tool will be actuated to then be able to releasably engage a selected sleeve or sleeves, and movement of the coil and affixed actuation tool uphole causes displacement of said selected sleeve or sleeves to a position so as to re-open (or re-close) the sleeves.

Other known and commonly employed methods of selectively actuating sliding
15 sleeves so as to successively open or close said sleeve or sleeves will now occur to persons of skill in the art. Such alternative methods for actuating the sliding sleeves are likewise contemplated for use in the method of the present invention.

In accordance with methods herein, the injection fluid may be a gas.

Alternatively, or in addition, the injection fluid may be a gas selected from the group
20 of gases comprising natural gas, gases contained within and obtained from the produced oil, CO₂, and mixtures thereof.

In a further embodiment, where the injection fluid is a gas, such gas is miscible in oil.

In addition, where the injection fluid is a gas, the injection fluid may be obtained from a gaseous fraction recovered from the produced oil, and may be recycled/re-used in the method
25 of the present invention to assist in increasing the motility of oil in the formation.

In a preferred embodiment, the gas fraction obtained from the produced oil is obtained by subjecting the produced oil when produced to surface to increased temperature and/or reduced pressure to thereby flash a small portion of volatile gaseous components within said produced oil, for subsequent use as the injection fluid in one or more of the methods of the present invention.

In a further or alternative embodiment the injected fluid is a gas which is entrained in, or produced from, from the produced oil, and is enriched in C2-C5 components. Such higher-carbon gaseous components/compounds assist when injected into the formation as the injected fluid, in increasing the motility of oil in the formation and thereby better sweeping such oil to the oil production fractures for subsequent collection and production to surface.

In a still-further embodiment, oil which is produced in accordance with one or more of the methods disclosed herein is heated and used to provide additional gaseous components for the injected fluid.

The injected fluid may be water, with or without additives, and/or may comprise both water and gas.

The above methods may be used for previously-unworked hydrocarbon formations, or hydrocarbon formations which have been worked but never previously been fracked to produce multiple induced fractures along the length of a wellbore therein.

Alternatively, the methods of the present invention may be used on hydrocarbon formations which have been previously worked and fracked, but which have not previously had the methods of the present invention applied to them. Stated otherwise, the methods herein may be applied when working of a hydrocarbon formation is first commenced or at any time in a lifecycle of the working and completion of a hydrocarbon reservoir.

With any of the above methods, , the period of time for said injecting of said injection fluid and pressuring up said formation will typically need to be carried out over a period extending from one day to 1 year, depending on formation porosity, permeability, and general length of fractures which are created in a formation.

5 Likewise, with any of the above methods, the period of time for recovering of said produced fluids (oil) will often need to be carried out over a period extending from one month to 10 years, considering typical formation porosity, permeability, and formation temperatures and pressures as often encountered, exemplars of which are specifically set out later in this specification.

10 In all embodiments of the present method, the fluid pressure of the injected fluid when injected from the lined wellbore is preferably equalized over its length to thereby uniformly inject injection fluid at a substantially constant pressure over the length of a horizontal portion the lined wellbore.

One manner of achieving equal pressure application of injection/driving fluid to the
15 fluid injection fractures is to provide the wellbore liner with a perforated tubing inserted within and extending substantially over a horizontal length of said portion of the wellbore, and having perforation patterns or sizes therein configured so as to equalize fluid pressure applied to said fluid injection fractures along the portion of the length of the lined wellbore. Specifically, for example, the cross-sectional area of apertures in said perforated tubing in said wellbore or the
20 cross-sectional area of apertures in said wellbore liner (which apertures are each in fluid communication with said fluid injection fractures) may be made larger in cross-sectional area at the distal (toe) end of the wellbore as opposed to at the heel or more proximate the surface, to account for the reduced fluid pressure of the injected fluid at the toe of the wellbore as opposed to the heel, so that the resultant pressure differential applied by the injected fluid will
25 be equalized.

Similarly, one manner of achieving equal pressure drawdown of recovered oil from the various oil production fractures along the length of a wellbore is to provide the wellbore liner with a perforated tubing inserted within and extending substantially over a horizontal length of said portion of the lined wellbore, and having perforation patterns and/or sizes therein configured so as to equalize fluid pressure of fluid draining into said wellbore over said length of said lined wellbore, to thereby allow uniform flow (recovery) rates from the individual oil production fractures. Specifically, for example, the cross-sectional area of apertures in said perforated tubing in said wellbore or the cross-sectional area of apertures in said wellbore liner (which apertures are each in fluid communication with said oil production fractures) may be made larger in cross-sectional area at the distal (toe) end of the wellbore as opposed to at the heel or more proximate the surface, to account for the more reduced pressure differential at such location as compared to the heel of the wellbore (where such oil is being withdrawn to surface typically under a negative (suction) pressures thus giving rise to an increased pressure differential that the oil production fractures are exposed to at the heel) , so that the resultant pressure differential applied at each oil production fractures at both the toe and heel is more approximately equal.

The foregoing summary of the invention does not necessarily describe all features of the invention. For a complete description of the invention, reference is to further be had to the drawings and the detailed description of some preferred embodiments, read together with the claims.

BRIEF DESCRIPTION OF THE DRAWINGS

Further advantages and other embodiments of the invention will now appear from the above along with the following detailed description of the various particular embodiments of the invention, taken together with the accompanying drawings each of which are intended to be non-limiting, in which:

FIG. 1 is a schematic diagram showing the initial step in one embodiment of the Intermittent Fracture Flooding process of the present invention, where fluid communication between the wellbore and the alternately-spaced multiple induced fluid injection fractures has initially been established, and fluid communication between alternately-spaced fluid
5 production fractures and the wellbore has been prevented/shut-in by movement of associated sliding sleeves within the wellbore;

FIG. 2 is a schematic diagram depicting a subsequent step in the Intermittent Fracture Flooding process of **Fig. 1**, wherein communication between the wellbore and the alternately-spaced multiple induced oil production fractures is established, and fluid
10 communication between alternately-spaced fluid injection fractures and the wellbore is prevented/shut-in, again by movement of sliding sleeves in the wellbore;

FIG. 3 is a schematic diagram showing of an initial step in a second embodiment in the Intermittent Fracture Flooding process of the present invention, wherein communication between the wellbore and the alternately-spaced multiple induced fluid injection fractures
15 is established, and fluid communication between alternately-spaced oil production fractures and the wellbore is prevented, by sliding movement of a single sliding sleeve situated at the respective locations of contact of all of the alternately-spaced fluid injection fractures and oil production fractures along the wellbore;

FIG. 4 is a schematic diagram depicting a subsequent step in the Intermittent Fracture
20 Flooding process of **Fig. 3**, wherein communication between the wellbore and the alternately-spaced multiple induced oil production fractures is established, and fluid communication between alternately-spaced fluid injection fractures and the wellbore is prevented/shut-in, again by movement of the single sliding sleeve in the wellbore;

FIG. 5 is a schematic diagram depicting a further optional step in any of
25 aforementioned methods of the present invention, wherein after producing for a time oil from the alternately-spaced oil production fractures, a coiled tubing may be inserted to the toe of the wellbore and a flushing fluid injected via said coil tubing into the toe of the wellbore to

thereby flush oil within the wellbore and recover same to surface, prior to injecting the injection/driving fluid in the wellbore for injection into the alternately-spaced fluid injection fractures;

FIG. 6 is a schematic diagram depicting an initial step in another embodiment of the method of the present invention, which method employs a series of sliding sleeves regulating fluid communication only between the wellbore and the oil production fractures, wherein the sliding sleeves are initially in the closed position preventing injection of injection fluid into the oil production fractures and wherein such injected fluid supplied to the wellbore flows into the fluid injection fractures;

FIG. 7 is a schematic diagram of the embodiment of the method shown in Fig. 10, wherein supply of injection fluid to the wellbore has been ceased, and the sliding sleeves have now been moved to the open position and oil is flowing into the wellbore from the oil production fractures and being produced to surface;

FIG. 8 is one example of a sliding sleeve within the casing for allowing and preventing, when in an open and closed position respectively, oil flowing into the wellbore from the oil production fractures within the formation, showing such sliding sleeve in the closed position;

FIG. 9 is a depiction of the sliding sleeve as shown in Fig. 8, but in the open position uncovering a port in the wellbore liner;

FIG. 10 is a schematic diagram depicting an initial step in another embodiment of the method of the present invention which employs a series of packers and two separate and distinct coil tubings, wherein a fluid injectant is supplied via a first tubing to alternately-spaced of the multiple induced injection fractures isolated from remaining alternately-spaced fractures;

FIG. 11 is a schematic diagram depicting a subsequent step in the Intermittent Fracture Flooding process of **Fig. 10**, wherein supply to fluid injectant via the first tubing is halted, and oil is allowed to flow from remaining alternating fractures into the second of the coil tubing, and produced to surface;

5 **FIG. 12** is a schematic diagram of the initial fluid injection step in another embodiment of the method of the present invention, which employs a series of packers and a single coil tubing, wherein a fluid injectant is supplied via the coil tubing to areas bounded by a series of packers and thus into the fluid injection fractures, and oil production fractures are shut-in /isolated;

10 **FIG. 13** is a schematic diagram of the subsequent oil production step in the method of FIG. 12, wherein the coil tubing and packers are move slightly uphole (or downhole) to thus align apertures in the coil tubing (and intermediate the packers) with the oil production fractures, and shut in the fluid injection fractures; and

Fig. 14 is a single combined series of graphs comparing oil recovery factor as a
15 function of time for a hydrocarbon formation, for:

a) continuous water Fracture Flooding (prior art);

b) continuous gas Fracture Flooding (prior art);

c) primary oil recovery (prior art);

d) Intermittent Fracture Flooding in accordance with a the method of the present
20 invention, using gas only as the injection fluid;

e) Intermittent Fracture Flooding for the first stage, then Intermittent water Fracture Flooding; and

f) Intermittent Fracture Flooding using only water as the injection fluid.

In obtaining each of the aforementioned results a)-e), two (2) years of primary production were undertaken, followed by [with the exception of curve (c)] with injection of gas or water, as the case may be, for a period of 4 months, continuously or intermittently, as
5 the case may be.

DETAILED DESCRIPTION OF SOME PREFERRED EMBODIMENTS

Fig. 1 shows a schematic diagram of an initial step, and **Fig. 2** a subsequent step, of in one embodiment of the intermittent pressure-up blow-down method 100 of the present invention for recovering oil from an underground hydrocarbon formation **1** having a lined
10 wellbore **9** therein.

Fig. 3 similarly show a schematic diagram of an initial step, and **Fig. 4** a subsequent step, of another embodiment of the intermittent pressure-up blow-down method **100** of the present invention.

In all embodiments, method **100** of the present invention is adapted to be worked in a
15 hydrocarbon formation **1**, namely a hydrocarbon-bearing deposit **1** typically situated between an upper non-hydrocarbon-containing layer **3**, and a lower non-hydrocarbon-containing layer **5** typically consisting of cap rock. Hydrocarbon formation **1** may have a pre-existing wellbore **9** or a newly-drilled lined wellbore **9**, and has such formation **1** has been fractures along a portion (preferably but not necessarily a horizontal portion) of the wellbore **9** been completed
20 by any of the known hydraulic fracturing methods so as to have created multiple induced fractures **40a**, **40b** spaced along a portion of a length of wellbore **9** having liner **10** therein. Multiple induced fractures **40a**, **40b** extend radially outwardly from such lined wellbore **9**.

In the embodiment of the method shown in **Fig. 1 & 2**, a series of sliding sleeves **30a**, **30b** are provided installed along a portion of the length of a lined wellbore **9**, namely along the wellbore casing.

5 An actuator tool, as commonly known in the art (not shown), may be inserted down the wellbore **9** at the end of coil tubing (not shown) so as to initially actuate/move sliding sleeves **30a** to an open position. Alternatively sliding sleeves **30a** may be initially installed along lined wellbore **9** in an open position when such wellbore casing is inserted in the well, to initially allow fluid communication between wellbore **9** and fluid injection fractures **40a**.

10 Similarly, as regards sliding sleeves **30b** which regulate fluid communication between wellbore **9** and oil production fractures **40b**, such sliding sleeves **30b** may be initially installed along lined wellbore **9** in a closed position when such wellbore casing is inserted in the well, to initially prevent fluid communication between wellbore **9** and oil production fractures **40b**, and may be subsequently opened when desired by the insertion downhole of an actuation tool as discussed.

15 Alternatively, sliding sleeves **30b** may be of the type shown in **Figs. 8 & 9**, wherein supply of a high pressure fluid within wellbore lining **9** enters port **20** and cavity **18**, causing compression of spring **15** in cavity **14** and movement of sliding sleeve **30b** to cover port **8** thereby shutting in oil production fractures **40b** from fluid communication, as shown **Fig. 8** and in **Fig. 1**.

20 Injectant fluid **70**, under relative pressure ΔP , can then be supplied to fluid injection fractures **40a** for a time sufficient to pressure up formation **1** by injectant fluid **70** driving oil and associated hydrocarbons in such formation **1** towards alternately spaced oil production fractures **40b**.

25 Thereafter, at a time when formation **1** has become sufficiently pressured up, the supply of injectant fluid to wellbore **9** and fluid injection fractures **40a** is ceased. Cessation

of fluid pressure in wellbore **9**, if sliding sleeves **30b** are of a type shown in **Fig. 9**, by operation of spring **14** in cavity **15**, causes sliding sleeves to then be moved so as to uncover associated ports **8** thereby allowing oil to flow from the hydrocarbon formation **1** into wellbore **9** via oil production fractures **40b** so as to then be capable of being flowed to surface **4** via wellbore **9**.
 5 Alternatively, sliding sleeves **30b**, if not of the type shown in **Figs. 8, 9** and requiring physical manipulation, may likewise be moved to the open position by the same actuation tool inserted down the wellbore **9** to close sliding sleeves **30a**, to then allow the wellbore **9** to receive oil from oil production fractures **40b**.

10 Thereafter, upon the rate of recovery of oil **72** from wellbore **9** falling off as oil is produced, the above method may be repeated, so as to re-pressure the formation **1** and again drive additional oil and hydrocarbons to oil production fractures for subsequent recovery.

15 **Figs. 3 & 4** show another embodiment of the above method, wherein as shown in **Fig. 3** the initial opening of ports **7** allowing supply of injectant fluid to fluid injection fractures **40a** and the initial shutting-in of oil production fractures **40b**, is accomplished by initially positioning a sliding sleeve **30** having ports **30a'** and **30b'** therein in a first position allowing fluid communication between wellbore **9** and fluid injection fractures **40a** via ports **30a'** therein, and simultaneously isolating oil production ports **40b** by preventing from fluid communication by closing ports **30b'** and thereby preventing fluid communication with wellbore **9**.

20 To transition to the oil recovery phase of the Intermittent Recovery Process of the present invention, sleeve **30** is slidably moved (via an actuation tool as described above being inserted downhole) to a second position, as shown in **Fig. 4**, wherein sliding sleeve **30** then prevents fluid communication via ports **30a'** therein with fluid production channels **40a** but allows fluid communication of oil production channels **40b** with wellbore **9** via ports **30b'**
 25 therein.

Fig. 5 shows an optional additional step in the method of the present invention, wherein after completion of the oil production phase (**Fig. 2**, **Fig. 4**, **Fig. 7**, **Fig. 11** & **Fig.**

13) but prior to the re-injection of fluid injection phase (**Fig. 1, Fig. 3, Fig. 6, Fig. 10 & Fig. 12**), residual oil remaining in wellbore **9** is flushed by injecting the injectant fluid **70** at the toe **80** of the wellbore **9** via a coil tubing **82** extending to toe **80**, and re-producing such injectant fluid back to surface **4**. In such manner residual oil is produced to surface **4**, rather
5 than being intermingled with injection fluid **70** and being re-injected into formation **1** during the subsequent fluid injection phase.

Each of the embodiment shown in **Figs. 1 & 2** and the embodiment shown in **Figs. 3 & 4** employ a shut-in means such as sliding sleeves **30a, 30b** shown in **Fig. 1, 2** or a single sliding sleeve **30** having ports **30'** thereon as shown in **Figs. 3 & 4**, for shutting in (when
10 desired) each of the associated fluid injection fractures **40a** and oil production fractures **40b**, respectively, and preventing fluid communication of each with wellbore **9**.

It is not necessary, however, in order to practice the method of the present invention, for there to be installed sliding sleeves **30a, 30b** or a single sliding sleeve **30** to regulate fluid communication between both the fluid injection fractures **40a** and the oil production fractures
15 **30b**.

Rather, in a further embodiment of the method of the present invention, as shown in **Figs. 6** (fluid injection) & **Fig. 7** (oil production), sliding sleeves **30b** or a sliding sleeve **30** may simply be provided to regulate flow of fluid only through ports **8** in lined wellbore **9** so as to thereby only regulate fluid communication of the oil production fractures **40b** with the
20 wellbore **9**.

No regulation of fluid communication of wellbore fluids with fluid injection fractures **40a** in this particular method is thus required.

In such embodiment/method, sliding sleeves **30b** or sliding sleeve **30** may be of the type which are opened/closed by means of an actuation tool (not shown).

Alternatively, sliding sleeves **30b** may be of the type as shown in **Fig.'s 8, 9** wherein when fluid injectant under a fluid pressure **P** is supplied to wellbore **9** associated sliding sleeves **30b** are caused to move in the manner described above so as to cover ports **8** and thereby prevent injectant fluid being injected into oil production fractures **40b**. In such
5 manner the injectant fluid is only supplied via the open ports **7** in wellbore liner **9** to the fluid injection fractures **40a** during the pressure-up phase of the method.

Upon cessation of the first pressuring-up phase of this refined method, and the transition to the second blow-down phase wherein supply of pressurized injectant fluid **70** is ceased, such absence of pressure causes springs **14** (ref. **Fig. 9**) to return sliding sleeve to an
10 open position uncovering port **8** in wellbore liner **9**, thereby allowing oil **72** to flow into wellbore **9** via oil production fractures **40b** and be produced to surface **4**.

The multiple sliding sleeves **30a, 30b** (**Figs. 1, 2**) and the single sliding sleeve **30** of **Fig. 3, 4**, and the further single series of sliding sleeves **30b** of **Figs 6 & 7** regulating fluid communication only with oil production fractures **40b**, are all simply one manner of isolating
15 respectively at least the oil production fractures **40b** from wellbore **9** when injecting injectant fluid **70**.

The present invention further embodies and encompasses methods of intermittently and repeatedly pressuring up and blowing down a reservoir, in the manner described herein, without using a sliding sleeve or sleeves.

20 In this regard, **Figs. 10-11** and **Figs. 12-13** each show two further alternative embodiments of the method **100** of the present invention where no sliding sleeves are used, and instead a series of packer **25** are used to effect isolation of the oil production fractures **40b** from the fluid injection fractures **40a**.

Figs. 10 & 11 show a method using a series of (preferably expandable) packer
25 elements **25** through which separate dual tubing, namely a fluid injectant coil **43** and a

separate oil production coil 44 passes. As seen from **Fig. 10** (the initial fluid injectant phase of the method), the packer elements 25 and coils 43, 44 are placed downhole in lined wellbore 9, with packer elements 25 on opposite sides of ports 7 and 8 along wellbore liner 9. Injectant fluid is first injected into coil 43, and flows out apertures 63 and thus into fluid injection fractures 40a via ports 7 in wellbore liner 9.

Upon pressuring up of formation, injection of injectant fluid 70 is ceased (**Fig. 11**). Thereafter, as seen from **Fig. 11** (i.e. the second production phase of the method), produced oil 72 flows into ports 68 in coil 44 via ports 8 in lined wellbore 9, and is produced to surface 4. Upon the rate or quantity of oil 72 from formation 1 dropping below a predetermined rate, the aforementioned steps are again repeated.

Fig.'s 12 & 13 similarly show another method using a series of (preferably expandable) packer elements 25 through which passes a single coil 45, which single coil 45 is alternately used first as a fluid injectant conduit and subsequently as an oil production conduit. No sliding sleeves are needed in this embodiment.

As seen from **Fig. 12** (the initial fluid injectant phase of the method), the packer elements 25 and single coil 45 are initially run downhole in lined wellbore 9, with packer elements 25 positioned along the lined wellbore 9 on opposite sides of ports 7 and 8 along wellbore liner 9.

As seen from **Fig. 12**, injectant fluid is first injected into coil 45 and flows out apertures 65 therein and thus into fluid injection fractures 40a via ports 7 in wellbore liner 9.

After a time and upon pressuring up of formation 1, injection of injectant fluid 70 is ceased.

The series of packer elements **25** and coil **45** are together pulled slightly uphole, to now align apertures **65** in coil **45** with ports **8** in lined wellbore **9**, thereby allowing oil **72** to flow into ports **65** in coil **45**, and thereafter is produced to surface **4**.

Examples

5 Example 1

Gas was employed as the injection fluid for all four stages, as described below.

A first stage comprising a primary depletion stage of 2 years and a period of 4 months where gas was injected into the formation.

Specifically, after a period of 2-years of primary depletion, and with reference to **Figs.**
 10 **1 & 2**, sliding sleeves **30b** were closed, isolating associated oil production fractures **40b** from the horizontal wellbore **9**. Then the sliding sleeves **30a** were opened and gas (methane) was injected into the wellbore **9** from the surface **4**, which gas entered thus-opened fluid injection fractures **40a** and penetrated the adjacent reservoir matrix **5**, thus moving oil forward and pressurizing the reservoir **6** to a target maximum value, limited so as to not fracture the rock
 15 further. After 4-months of injection, when the gas injection rate had fallen to a pre-determined minimum, injection is deemed complete and fluid injection fractures **40a** were shut-in by closing associated sliding sleeves **30a**, while the oil production fractures **40b** were opened to the wellbore **9** by moving sliding sleeves **30b** to the open position, for a period of 2-years.

The second stage (stage 2) was begun by closing sleeves **30b** thereby isolating the oil
 20 production fractures **40b**, and opening sliding sleeves **30a** to allow fluid communication between wellbore **9** and fluid injection fractures. For a brief period, the fluid injection fractures **30a** were produced through sleeves **30a** into the wellbore **9** and to surface **4** in order to flush the wellbore **9** of production fluids. Thereafter, gas was injected into the fluid injection fractures **40a** via wellbore **9** for a period of 4 months. Sliding sleeves **30a** were subsequently

closed thereby isolating the associated fluid injection fractures **40a**, followed by opening of sleeves 30b to allow oil to flow into wellbore **9** via oil production fractures 40b now opened to fluid communication with wellbore **9**, to allow wellbore to produce and flow such oil to surface 4.

- 5 The above procedures of stage 2 were repeated for two more stages (stages 3 & 4), with stages 3 & 4 each being a successive iteration of above stage 2.

Example 2

The procedures of Example 2 were the same as for Example 1, except that the injection fluid was gas for the first stage and water for the next 3 stages.

10 Example 3

The procedures of Example 3 were the same as for Example 1, except that the injectant was water for all stages.

Numerical simulations of Examples 1-3 and additional Examples for Comparative Purposes

- 15 In order to demonstrate the efficacy of the intermittent injection methods of the present invention over the prior art, six (6) cases of numerical simulations were conducted using the Computer Modelling Group's STARS reservoir modeling software starting with a standard CMG model as modified, with the parameters of Table 1.

- 20 Above Examples 1-3 were simulated using the above computer modelling software, as well as three(3) prior art cases: primary recovery, continuous gas injection, and continuous water injection, using the software parameter inputs and conditions set out in **Table 1** below:

Table 1. - Numerical simulation parameters

| Reservoir | Value | Units |
|---------------------------------|--------------|------------------|
| Temperature | 73 | Degree Celsius |
| pressure | 17,000 | kPa |
| Maximum safe injection pressure | 23,000 | kPa |
| Horizontal permeability | 0.50 | mD |
| Vertical permeability | 0.05 | mD |
| Oil saturation | 50 | % |
| Water saturation | 50 | % |
| Fracture permeability | 2000 | mD |
| Oil density | 45 | Degree API |
| Gas-oil-ratio | 64 | Dissolved in oil |
| Model Parameters | | |
| Grid block size, I, j, k | 1, 5, 1 | meters |
| Number Grid blocks, I, j, k | 200, 10, 40 | number |

| | | |
|---------------------------|--------|--------------|
| (1/4 element of symmetry) | | |
| Full model volume | 1.6E06 | Cubic meters |
| Bottom-hole pressure | 100 | kPa |

A generic “tight” reservoir having light oil (Oil density of 45°API) was assumed, and the model employed an element of symmetry representing ¼ of the affected reservoir.

For all simulations, the reservoir was first produced under primary production for 2-years. Then 4-stages of injection and production were conducted. The injection periods were 4-months duration and the production periods were 2-years duration. This is not to limit the possible injection or production intervals, which will depend upon the availability of injection fluids, the spacing of the fractures, the fluid injection rates, reservoir permeability and other factors familiar to those knowledgeable in the art. The present Intermittent Fracture Flooding Process can be applied at any time during the life of the well, including at start-up.

The results of the aforesaid simulated scenarios are graphically displayed in **Fig. 6**.

In a preferred embodiment of the method of the present invention and referring to line e) in **Fig. 6**, a first stage of gas injection is conducted because this provides the largest increase in oil rate and oil recovery factor relative to the primary recovery factor.

However, as may be seen from **Fig. 6**, in subsequent stages the advantage of gas injection over water injection is only slight [cf. line ‘a’ as compared to line ‘b’, respectively]] and indeed in later stages water injection has a higher oil recovery factor. Accordingly, since gas compression costs are considerably higher than for water injection with a pump, it is more economical to switch to water injection after the first stage.

In a more preferred embodiment, the option of miscible gas injection for all stages can be undertaken. This can be accomplished with the produced fluids in at least two ways. Firstly, the produced gas can be re-cycled to establish multiple-contact miscibility, and secondly, the produced light oil (e.g. Bakken oil: 42 degrees, 7.2% C2-C5) can be heated to an appropriate
5 temperature, and/or subjected to decreased pressure to provide light hydrocarbons to the re-injected gas, so that a miscible injection gas flood can be established faster or even immediately.

While it might seem imprudent to deliberately flash off some of the oil product, it should be recalled that light tight oil from the Bakken and Eagle Ford formation is problematic
10 from the perspective of shipping safety as demonstrated by at least two recent devastating rail car explosions that were attributed to the high Reid vapor pressure of oil from those formations. The removal of light components from the sales oil would reduce the oil vapor pressure and improve transportation safety. In a further embodiment the Intermittent Fracture Flooding Process can also be enhanced by including within the horizontal well pressure-
15 equalizing equipment such as a perforated injection and production tubing with holes strategically designed to equalize pressure within the annular space.

The above description of some embodiments of the present invention is provided to enable any person skilled in the art to make or use the present invention.

For a complete definition of the invention and its intended scope, reference is to be
20 made to the summary of the invention and the appended claims read together with and considered with the detailed description and drawings herein on a purposive interpretation thereof.

CLAIMS

I claim:

1. A pressure-up, blow-down method to sweep oil from an underground hydrocarbon formation and recover same to surface, said hydrocarbon formation having at least four
5 uniformly-spaced induced fractures spaced along and contacting a portion of a length of lined or unlined horizontal wellbore situated in said hydrocarbon formation, said induced fractures extending substantially radially outwardly and upwardly from said wellbore, comprising the steps of :
- 10 (i) providing a coil tubing having proximate a distal end thereof at least two apertures therein, said apertures spaced along a longitudinal length thereof in accordance with spacing of alternating of said induced fractures along said horizontal wellbore;
- (ii) providing a plurality of pairs of actuatable packer members, each member of each pair positioned on said coil tubing so as to bound each aperture on respectively opposite sides thereof;
- 15 (iii) positioning said coil tubing, apertures therein, and pairs of packer members bounding said apertures along said horizontal wellbore such that said apertures in said coil tubing are each simultaneously aligned with alternatingly spaced of said induced fractures and further simultaneously positioned so as to prevent remaining of said induced fractures from having fluid communication with an interior of said coil tubing via said apertures therein;
- 20 (iv) actuating said packers within said horizontal wellbore so as to prevent fluid communication along said wellbore and between remaining of said induced fractures other than via said coil tubing;

(v) injecting a fluid within said coil tubing, and allowing said fluid to flow into said alternately spaced of said induced fractures, so as to pressure up said hydrocarbon formation;

(vi) de-actuating said packers;

5 (vii) moving said coil tubing and apertures therein bounded by said pairs of packers either uphole or downhole so as to simultaneously re-align said apertures in said coil tubing with remaining of said induced fractures along said horizontal wellbore; and

10 (viii) collecting oil which drains downwardly from said remaining induced fractures and passes into said coil tubing via said at least two apertures therein and producing same to surface.

2. The method as claimed in claim 1, further comprising the step, after step (viii), of successively additionally repeating each of steps (iii)-(vii) one or more times.

15 3. The method as claimed in claim 2, wherein said steps (v)-(viii) are initially conducted using a gas as the injection fluid, and successive iterations of steps (v)-(viii) are carried out using water as the injection fluid.

4. The method as claimed in claims 1, 2, or 3, wherein the injection fluid is a gas.

5. The method as claimed in claim 4, wherein said gas is miscible in oil.

6. The method as claimed in claim 1, wherein the injection fluid is a gaseous fraction which is obtained from said produced oil.

20

7. The method as claimed in claim 6, wherein said gas fraction is obtained from said produced oil by subjecting said produced oil to increased temperature and/or reduced pressure, to thereby flash volatile gaseous components within said produced oil for use of such volatile gaseous components as the injection fluid.
- 5 8. The method as claimed in claim 6 or 7, wherein the gas fraction is enriched in C2-C5 components.
9. The method as claimed in claim 4, wherein the injection fluid comprises a gas selected from the group of gases consisting of natural gas, gases contained within and obtained from said produced oil, CO₂, and mixtures thereof.
- 10 10. The method as claimed in any one of preceding claims 1-9, wherein a portion of oil which is produced in accordance with one or more of such methods is heated and used to flash volatile gaseous components therein to thereby provide additional gaseous components to the injected fluid.
11. The method as claimed in claim 1, wherein the injected fluid is water with or without
15 chemical additives.
12. The method as claimed in claim 1, wherein the injected fluid includes both water and gas.
13. The method as claimed in any one of preceding claims 1-12, wherein said method is first commenced at any time in a lifecycle of a completed hydrocarbon reservoir.
- 20 14. The method as claimed in any one of preceding claims 1-13, said injecting of said injection fluid and pressuring up said formation in step (v) is carried out over a period extending from one day to 1 year.

15. The method as claimed in any one of preceding claims 1-14, wherein said period of time in step (viii) for said recovering of said produced fluids is carried out over a period extending from one month to 10 years.

5

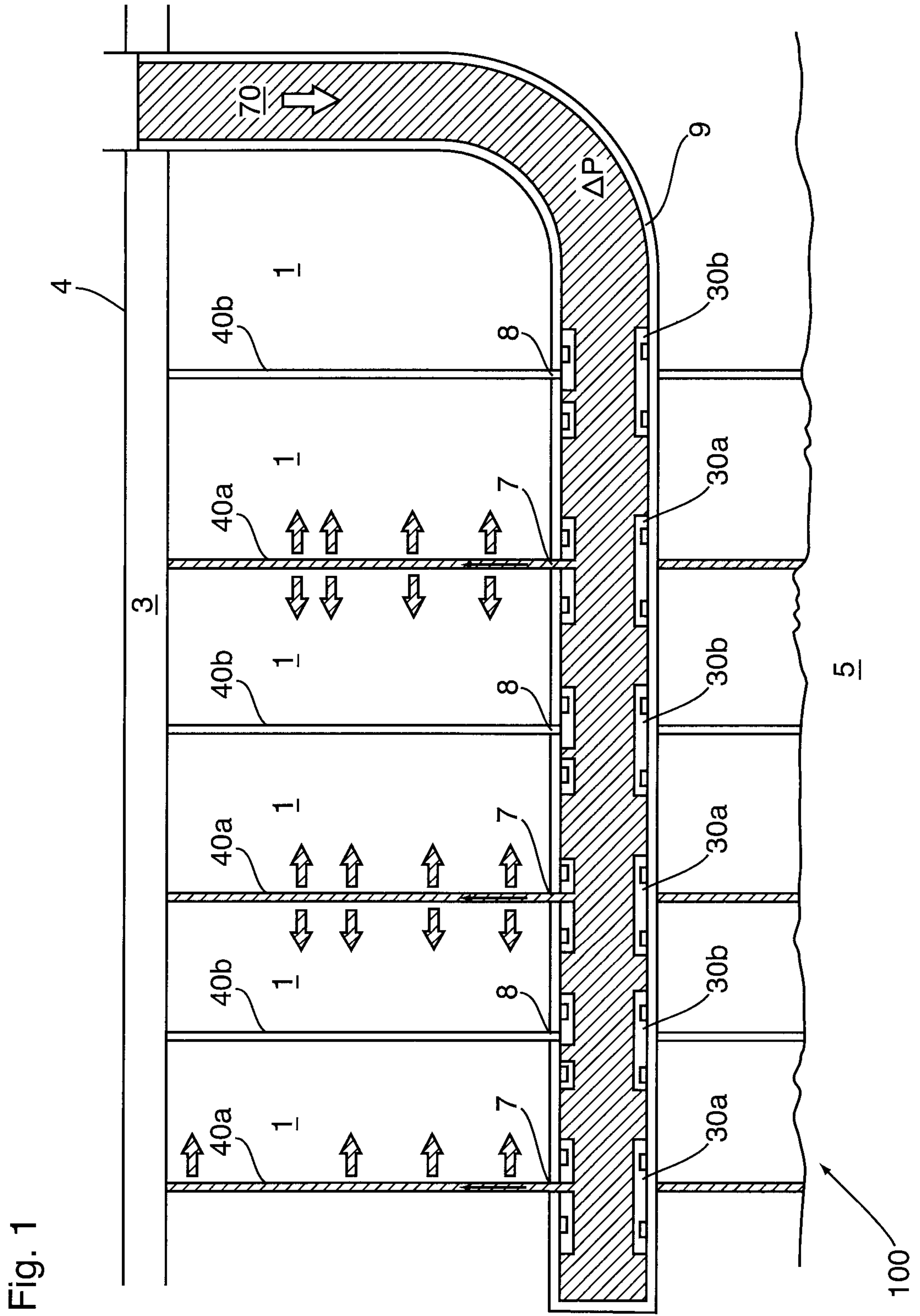

Fig. 1

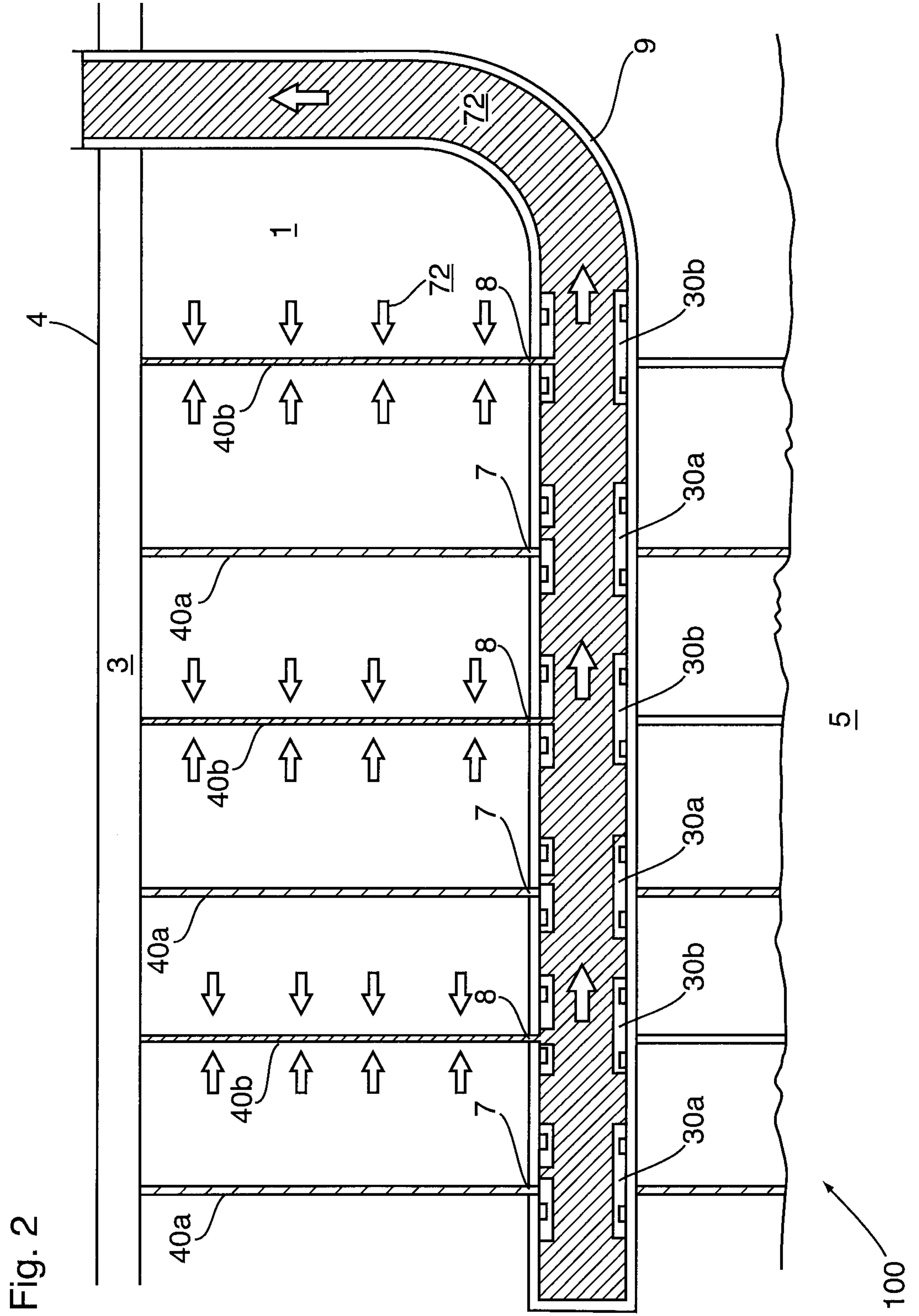

Fig. 2

100

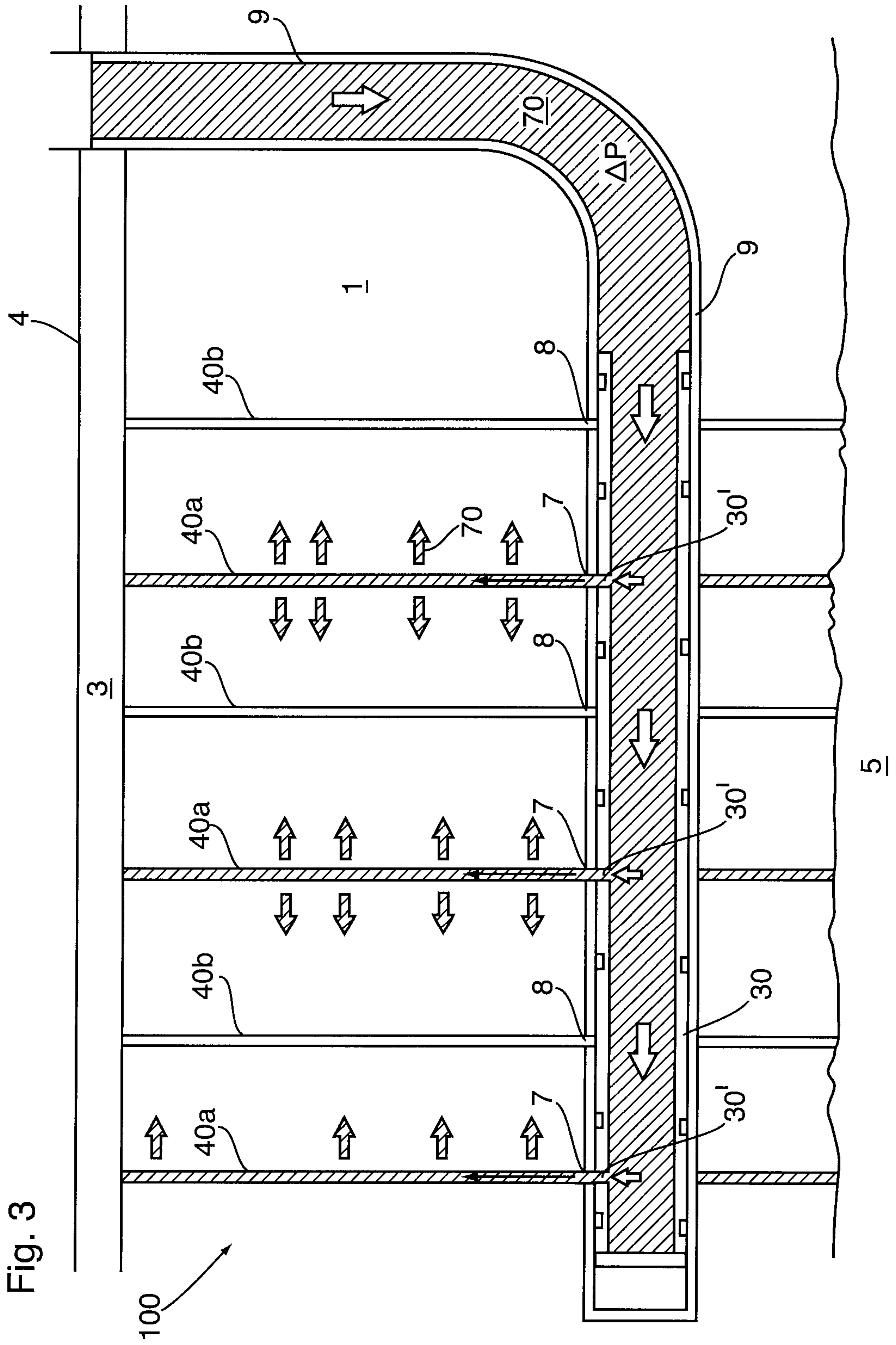

Fig. 3

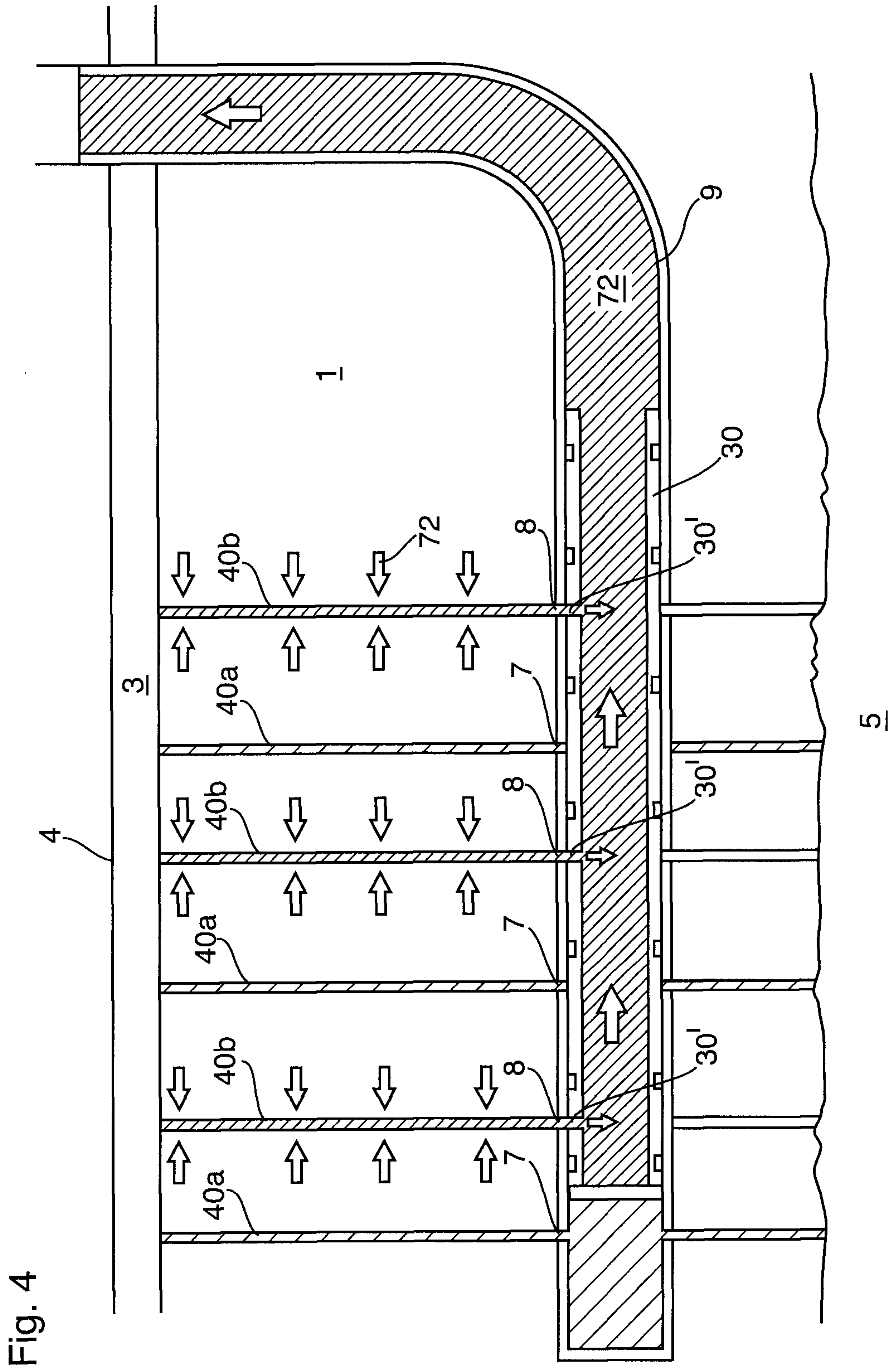

Fig. 4

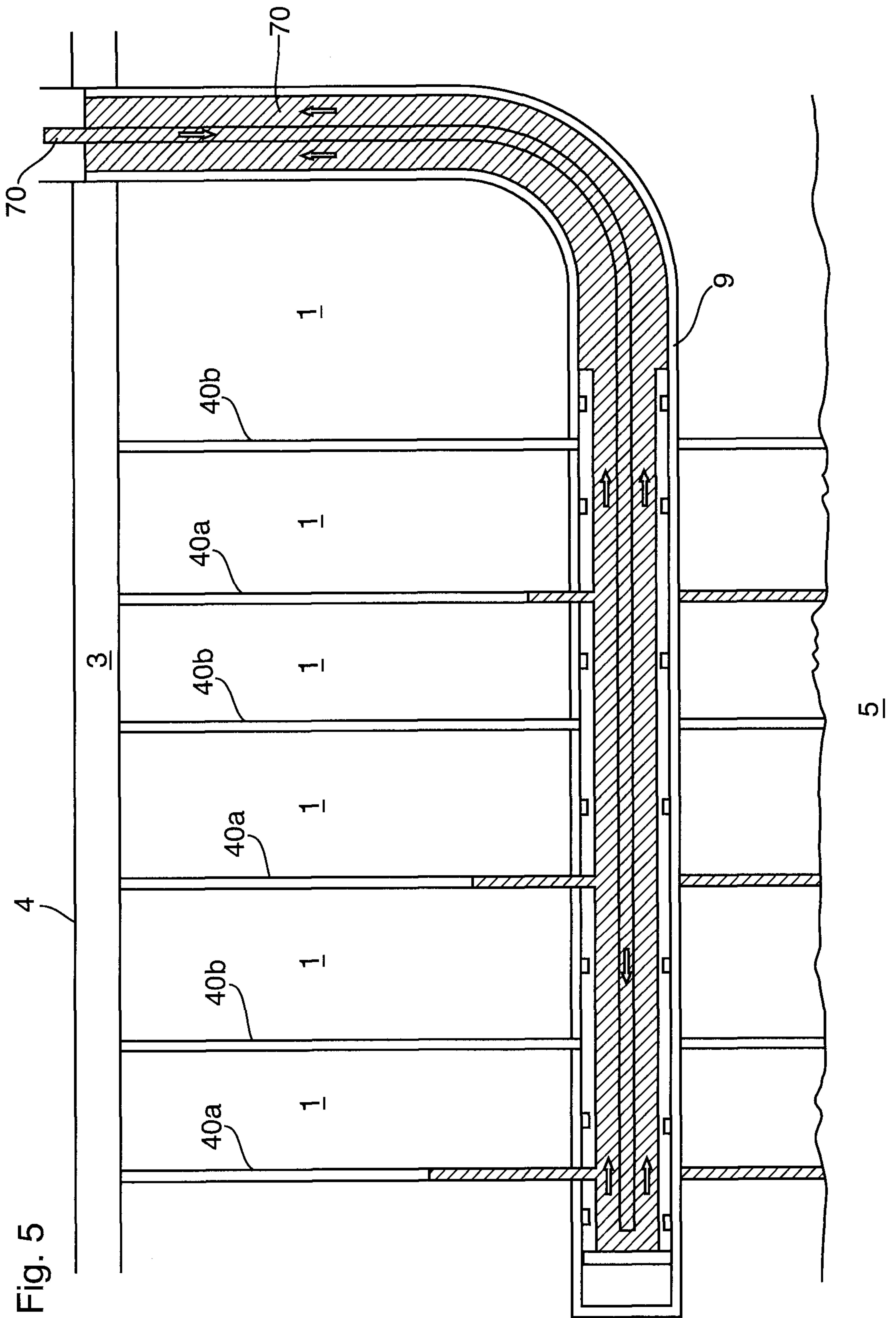

Fig. 5

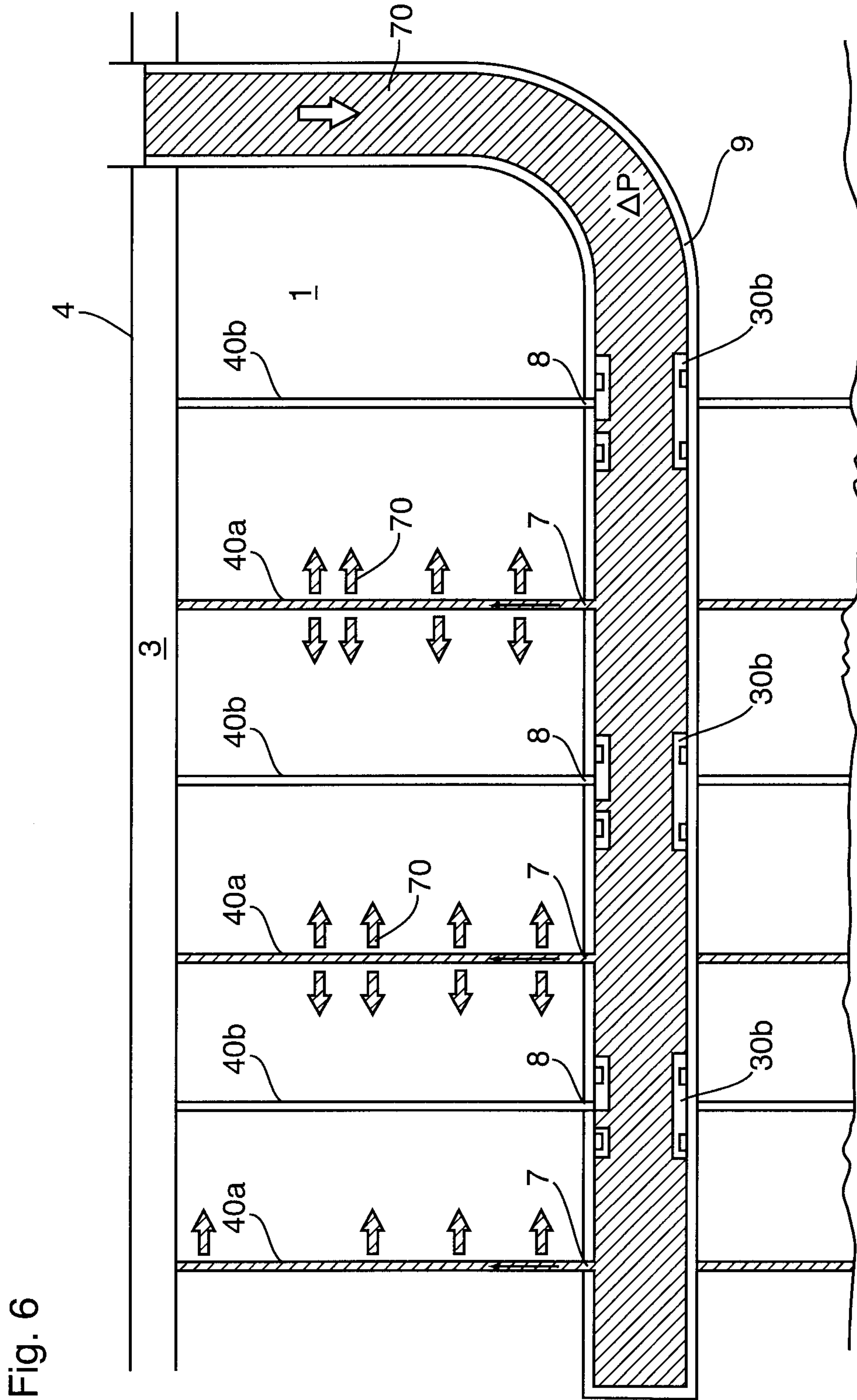
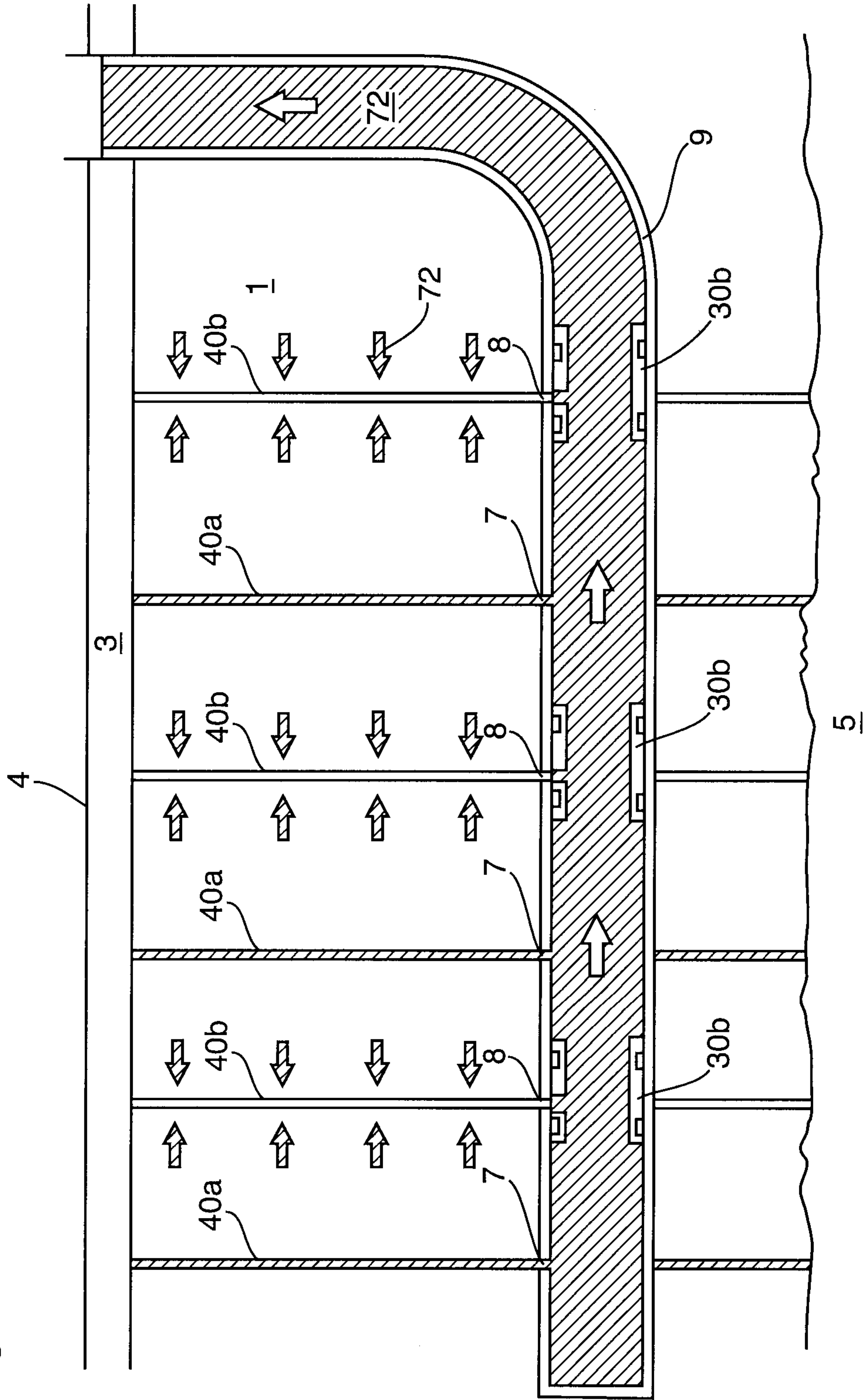
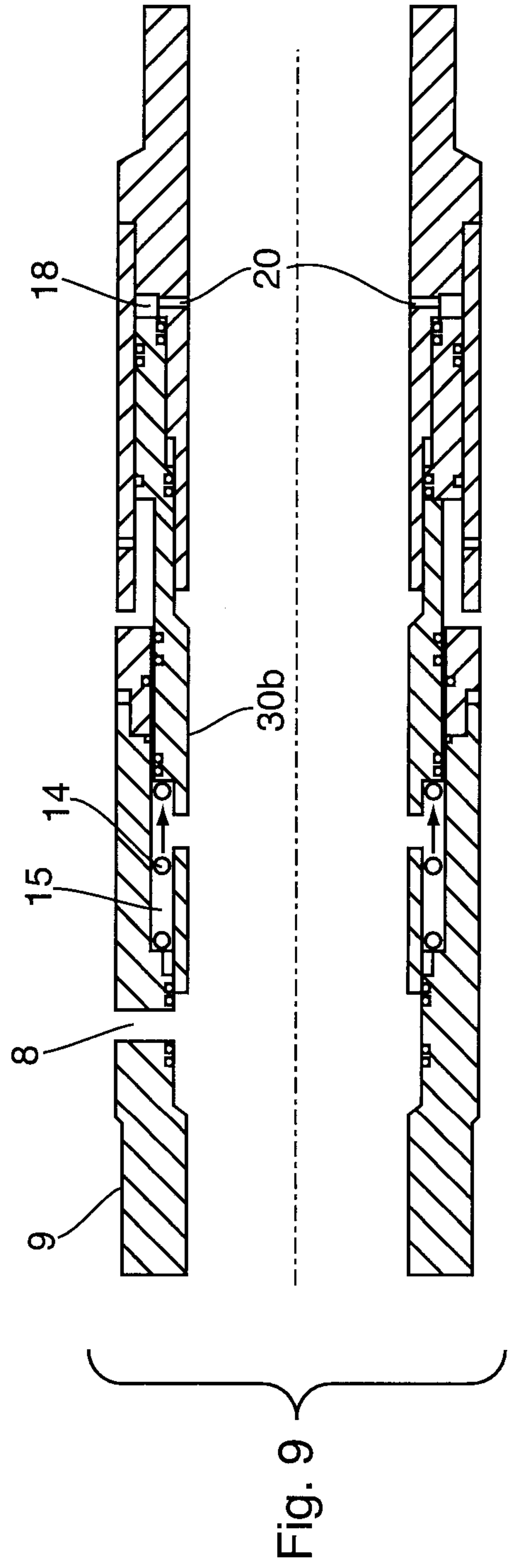
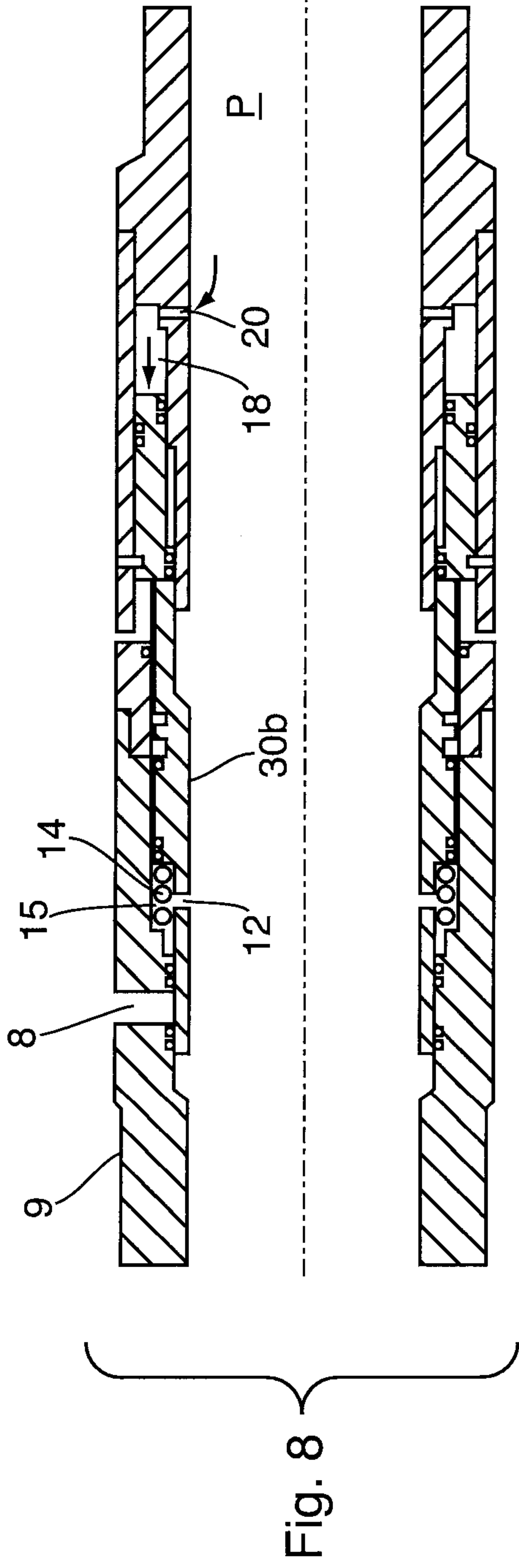

Fig. 6

Fig. 7





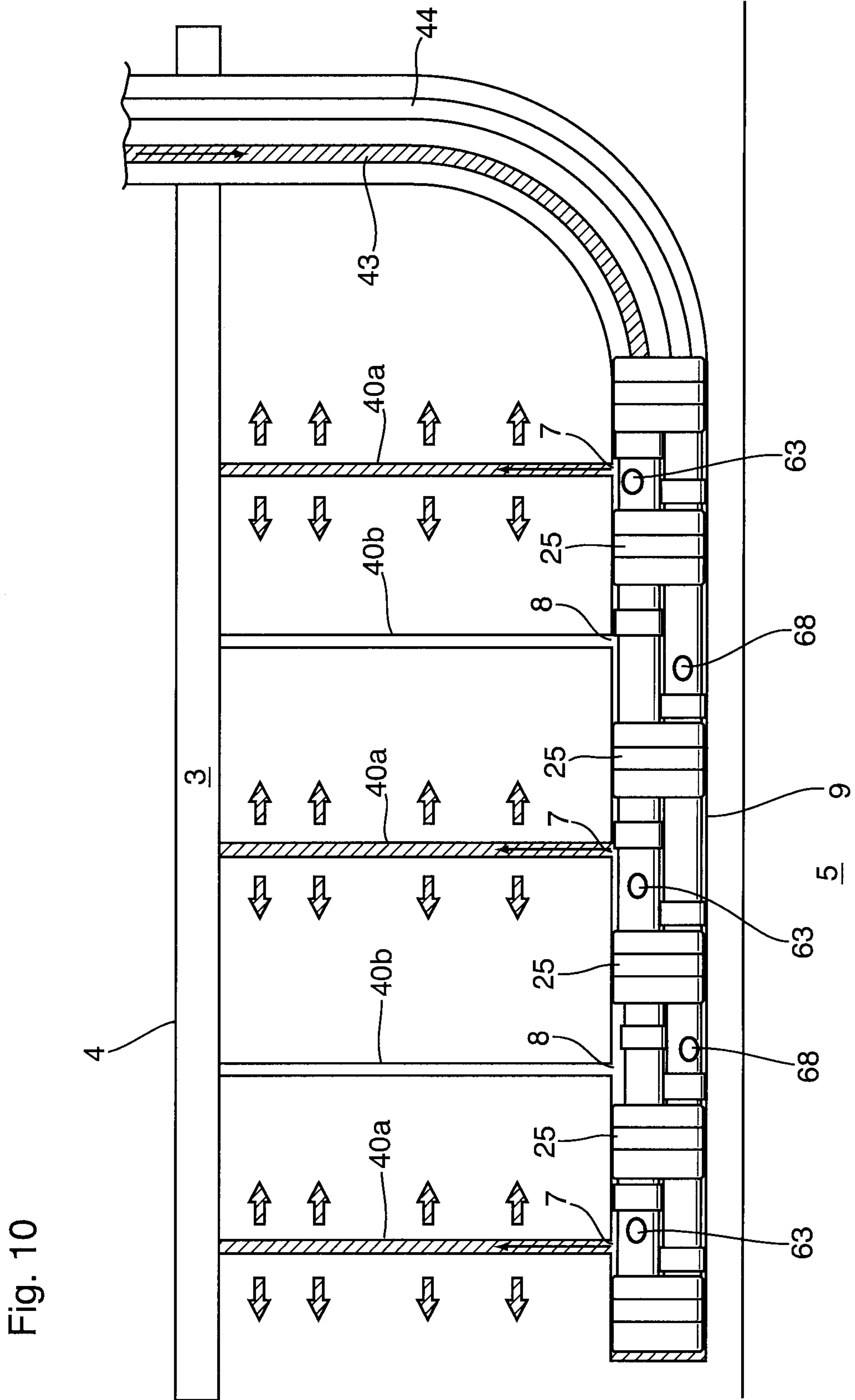

Fig. 10

Fig. 11

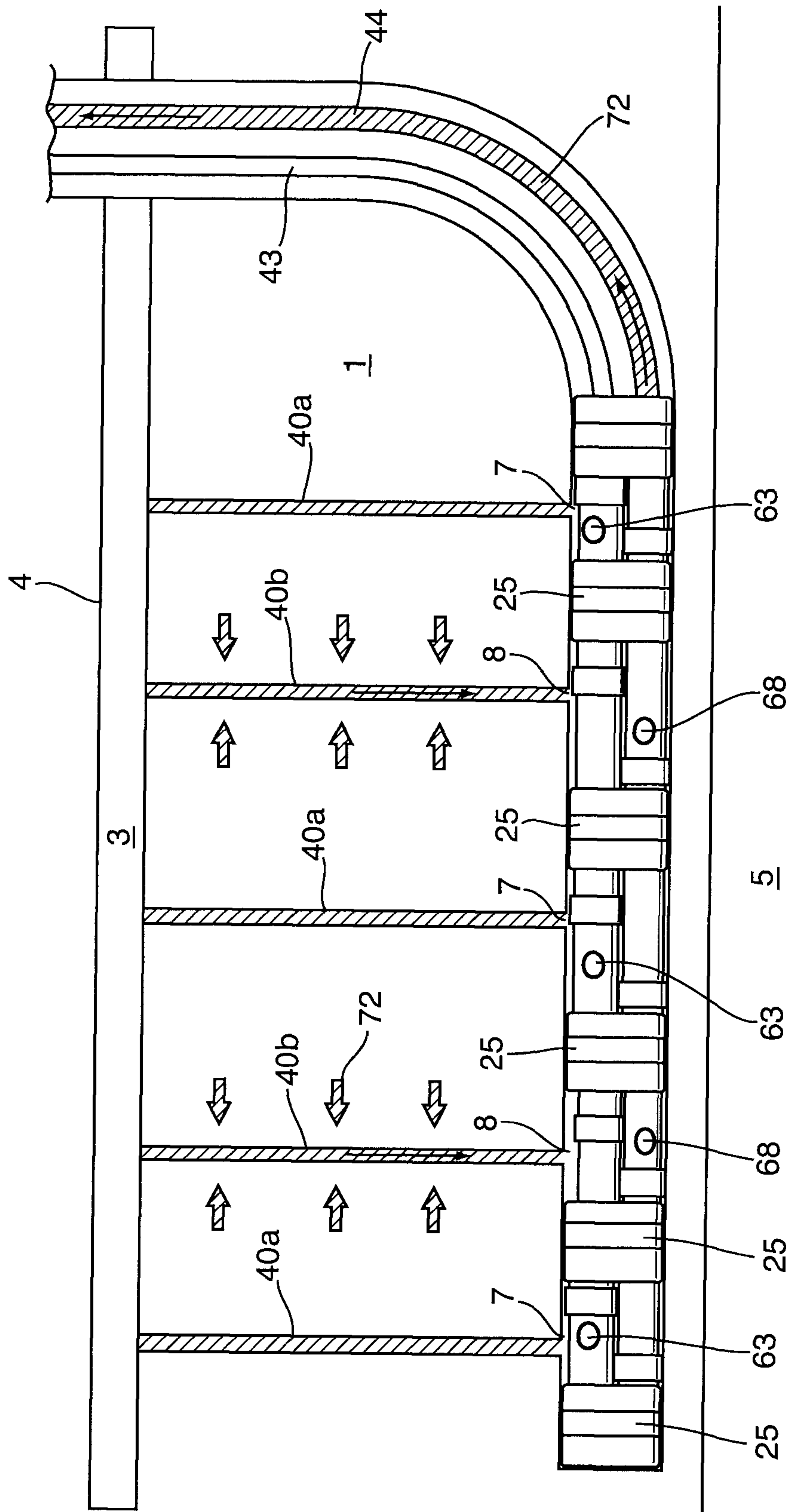
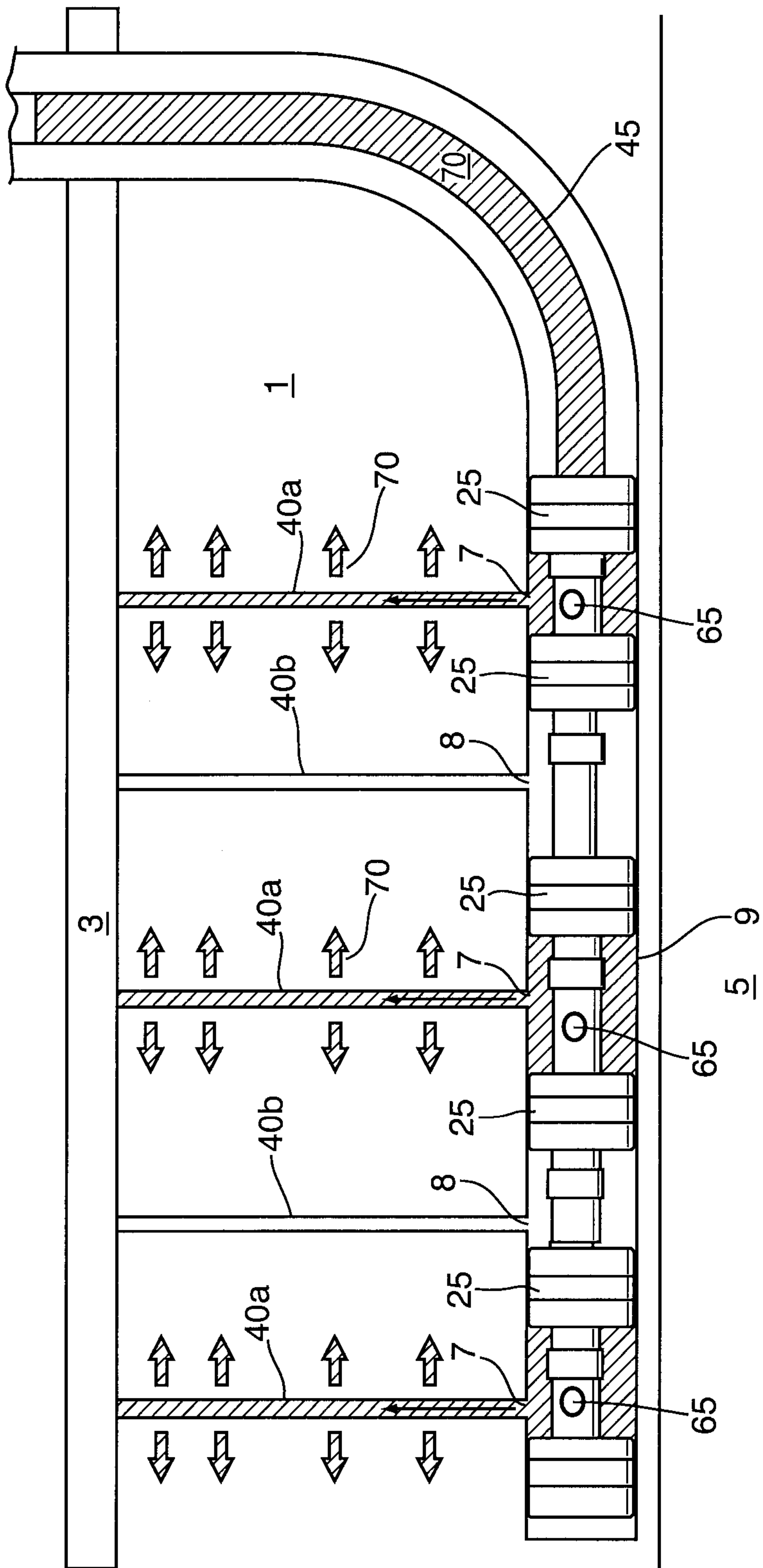

Fig. 12



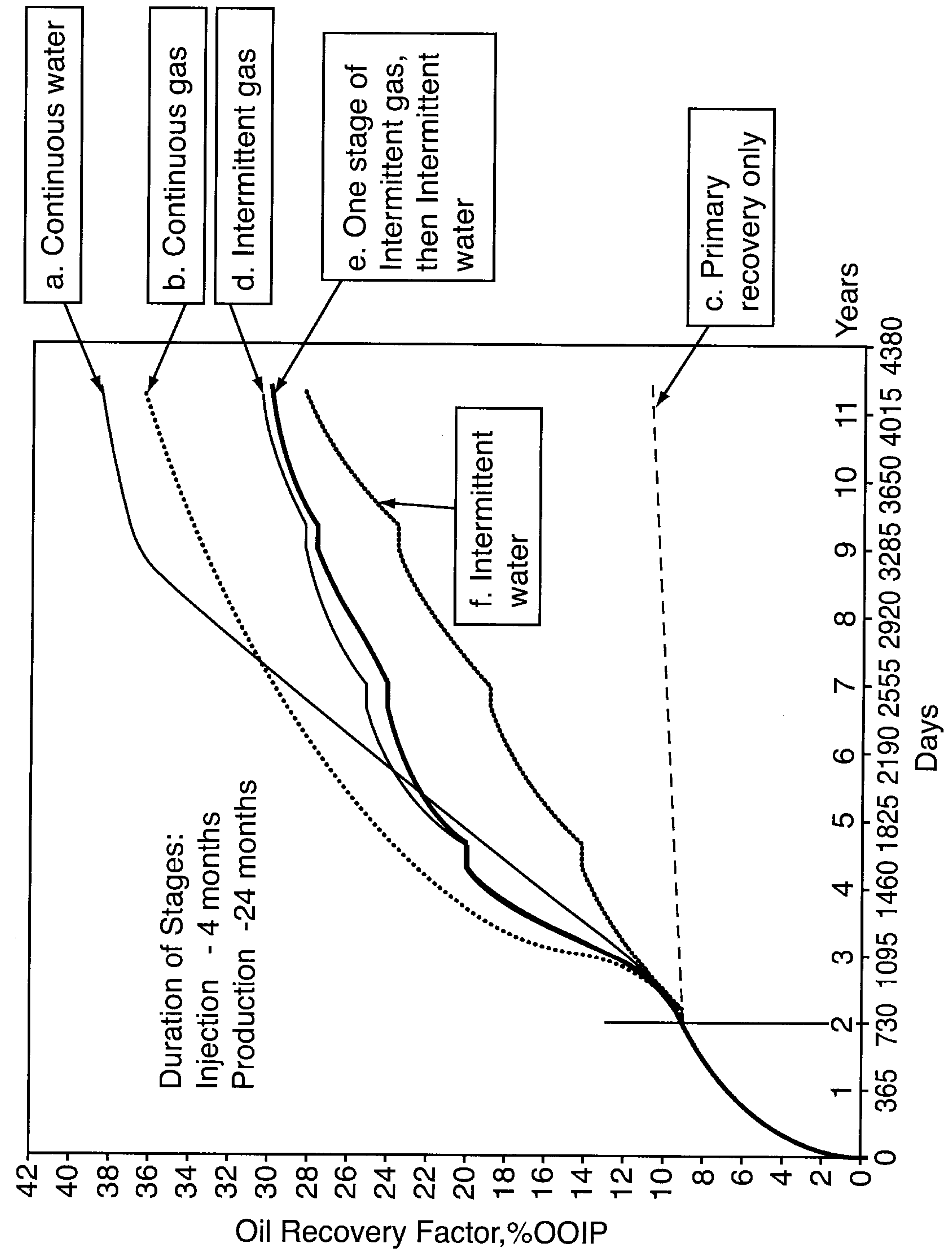

Fig. 14

