



(86) Date de dépôt PCT/PCT Filing Date: 2009/09/09
 (87) Date publication PCT/PCT Publication Date: 2010/04/01
 (85) Entrée phase nationale/National Entry: 2011/03/23
 (86) N° demande PCT/PCT Application No.: DE 2009/001282
 (87) N° publication PCT/PCT Publication No.: 2010/034286
 (30) Priorité/Priority: 2008/09/26 (DE10 2008 049 170.5)

(51) Cl.Int./Int.Cl. *F01D 21/00* (2006.01)
 (71) Demandeur/Applicant:
 MTU AERO ENGINES GMBH, DE
 (72) Inventeurs/Inventors:
 KNODEL, EBERHARD, DE;
 BORUFKA, HANS-PETER, DE;
 ARRIETA, HERNAN VICTOR, PL
 (74) Agent: MILLMAN IP

(54) Titre : DISPOSITIF ET PROCEDE POUR LE CONTROLE DE LA DUREE DE VIE
 (54) Title: DEVICE AND METHOD FOR SERVICE-LIFE MONITORING

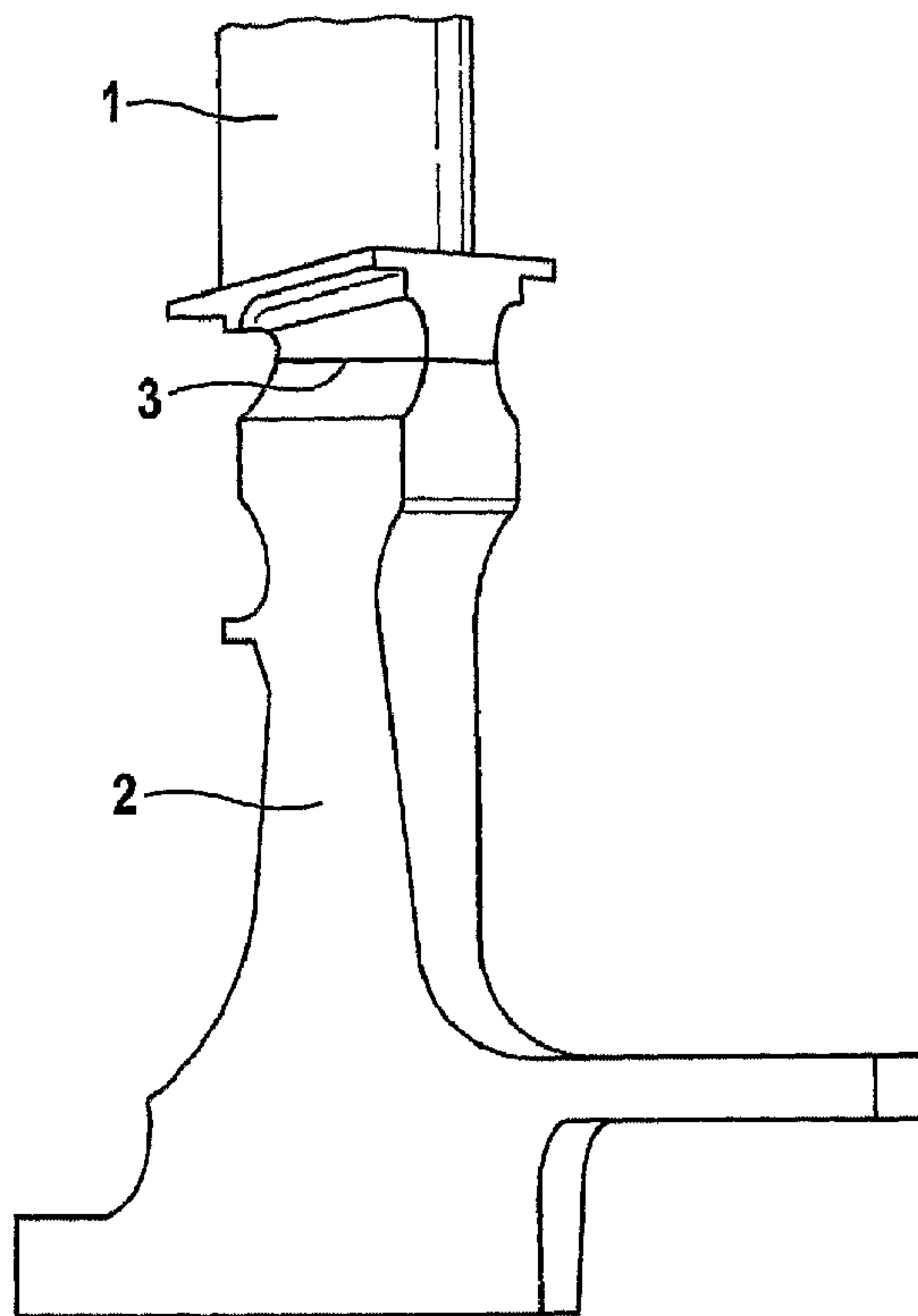

Fig. 1

(57) Abrégé/Abstract:

In an apparatus and a method for monitoring the service life of a power unit or a turbine having a compressor or turbine blisk, current stresses of the substructures of the blisk, such as the blade (1), the disk (2) and the connecting region (3) between the

(57) **Abrégé(suite)/Abstract(continued):**

blade (1) and the disk (2), are calculated on the basis of operating parameters measured during the ongoing operation of the power unit or the turbine, and cumulative damage to the individual substructures caused by the current stresses is estimated.

ABSTRACT

In the case of a device and a method for monitoring the service life of an engine or of a turbine having a compressor blisk and/or a turbine blisk, momentary stresses of blisk substructures, such as the blade (1), the disk (2), and the join region (3) between the blade (1) and the disk (2), are calculated on the basis of operating parameters that are measured in the course of engine or turbine operation; and accumulated damage to the individual substructures, that was caused by the momentary stresses, is estimated.

10

DEVICE AND METHOD FOR SERVICE-LIFE MONITORING

5 [0001] The European Patent Application EP 1 835 149 A1 describes a device and a method for monitoring the operation of a turbine. For this purpose, temperature sensors are used to monitor a component at various locations with respect to its tensile stress condition.¹ The finite method is used to further process the measured temperatures into a characteristic quantity in order to describe the tensile stress condition.

10 [0002] The U.S. Patent Application 2004/0148129 A1 is concerned with diagnosing a damage condition of a stationary power turbine. The diagnostic accuracy is improved in that both operating information, as well as process information are processed during turbine operation. Operating information is understood to be the service life, in particular.

15

[0003] The present invention relates to a device and a method for monitoring the service life of engines or turbines having a compressor blisk and/or a turbine blisk.

20 [0004] Aircraft engines and stationary turbines must regularly undergo maintenance and be examined for any damage that occurred during operation. This regular monitoring can be supplemented by a service-life monitoring during operation in order to estimate in advance the stress level and the damage condition of the engine or the turbine and to facilitate a condition-based maintenance.

25 [0005] Such an on-board, service-life monitoring of aircraft engines during operation has been known for quite some time and was developed by the Applicant for the RB199 jet engines of the Tornado and EJ200 of the Eurofighter and the MTR390 turboshaft engine of the Tiger helicopter. This service-life monitoring employs different algorithms in order to calculate the momentary stresses of critical

¹ **Translator's note:** The published English Abstract of this European Patent Application has translated "Spannungssituation" as "voltage situation." In my opinion, it is "tensile stress condition" that is meant here, not "voltage situation." Of course, "Spannung" in German can mean both "voltage" and "stress or strain," so it is easy to see how this could have been mixed up.

engine components on the basis of operating parameters that are measured during operation of the engine. The accumulated damage to the engine component, that is caused by the momentary stresses, is subsequently estimated, and the service life that has been consumed to that point is ascertained.

5

[0006] Compressor blisks and turbine blisks are used in modern engines. The word 'blisk' is an abbreviated form in English of "blade integrated disk," which is composed of the words 'blade' and 'disk.' As the word indicates, in the case of one blisk, the blade and disk form one unit. This eliminates the need for assembly costs,
10 and a weight reduction is achieved.

10

[0007] Blisks can be manufactured by machining the blade profile from the outer contour of a forged disk or of a disk segment, or by permanently joining a blade, for example, by friction welding, to a disk or a disk segment. The enclosed drawing
15 shows a turbine blisk for a high-pressure turbine, where a blade 1 is joined via a welded joint 3 to a disk segment 2.

15

[0008] Depending on the type of engine and the position of the blisk, the design of the blisk may also include a supporting segment, which is also referred to in
20 English as a "shroud." U.S. Patent 5,562,419 describes an example of a compressor blisk that is provided with shrouds.

20

[0009] It is an object of the present invention to improve the service-life monitoring during ongoing operation of engines or turbines having a compressor
25 blisk and/or a turbine blisk.

25

[0010] In accordance with a first embodiment of the present invention, the objective is achieved by a device for monitoring the service life of an engine or of a turbine having a compressor blisk and/or a turbine blisk, as defined in claim 1. This
30 device has a read-in device for inputting operating parameters measured during the course of engine or turbine operation; a stress calculator for calculating the momentary stresses of substructures of the blisk on the basis of the measured

30

operating parameters; and a damage estimator for estimating the accumulated damage to the individual blisk substructures caused by the momentary stresses **[the stress condition at a given instant of time]**.

5 **[0011]** In accordance with a second embodiment of the present invention, a method for monitoring the service life of an engine or a turbine having a blisk is provided, as defined in claim 5. This method includes the steps of measuring the operating parameters in the course of engine or turbine operation, calculating the momentary stresses of substructures of the blisk on the basis of the measured
10 operating parameters, and estimating the accumulated damage to the individual blisk substructures caused by the momentary stresses.

[0012] The device according to the present invention and the method according to the present invention are distinguished in that calculations are not only made of
15 the momentary stresses of one single critical part of the blisk, but **[also]** of at least two blisk substructures. Moreover, the accumulated damage to the blisk is not estimated as a single total value; rather, the accumulated damage to the individual substructures is estimated. In this manner, it is possible to estimate the potential service life of the individual substructures, making possible a substantially more
20 accurate estimation of the total service life consumption of the blisk.

[0013] In the case of the present invention, included among the substructures for which the momentary stresses are calculated, are preferably at least two of the substructures: blade, disk, and, to the extent that it is present, the join region
25 between the blade, disk and shroud. These substructures are subject to greatly varying stress conditions during operation, which is why it is useful to differentiate among the individual stress conditions of these substructures and the individual, thus associated accumulated damage in these substructures.

30 **[0014]** In the case of the present invention, included among the momentary stress conditions which are calculated, are preferably at least two of the stress conditions: thermomechanical fatigue, creep, low-cycle fatigue, fatigue at high-cycle fatigue, as

well as hot-gas corrosion. These stress conditions are the most frequent failure mechanisms that limit the service life of the blisk, which is why it is advisable that they be taken into consideration when calculating the stress conditions and in the subsequent estimation of the accumulated damage.

5

[0015] Finally, damage tolerances are preferably used when estimating damage. This generally known concept provides that any damage that occurred during operation, from which cracks or other defects may arise and which may remain undiscovered for a defined period of time (for example, until the next mandatory
10 scheduled maintenance), be included in the calculation. In other words, a time buffer is included in the calculation to ensure that the blisk is never able to reach the danger zone.

[0016] In this manner, the present invention makes it possible for the operating
15 parameters measured during operation to be used to estimate the accumulated damage in the individual substructures of the blisk **[to enable]** an individual and risk-minimized utilization of the potential service life of the blisk. This makes it possible to improve the planning of maintenance work and to lower operating costs. Therefore, the device according to the present invention and the method according to the
20 present invention are especially suited for developing an optimized maintenance strategy, which may include both repairing, as well as replacing the damaged blisk.

[0017] To illustrate the inventive principle, further details and features of the present invention are described in the following.

25

[0018] In the case of aircraft engines, it turns out that the service life consumption and the damage progression are only roughly dependent on the total flight time. Thus, in particular, the starting and stopping of the engine and individual flight maneuvers, which lead to power peaks during the flight, substantially influence the
30 service life of the individual engine components. A change in the control software or modification to the hardware of the engine may likewise affect the service life. For that reason, it is useful to monitor the service life consumption of the critical

components of an engine, for instance, of compressor blisks and turbine blisks, during operation.

[0019] Included among the operating parameters of the engine that may be measured during operation, are, in particular, the intake conditions, the rotational speeds, as well as the temperatures and pressures prevailing in the gas channel and the cooling-air channels.

[0020] Among the factors that stress the engine components are, first and foremost, the thermal stresses due to the temperature distribution in the component, and mechanical stresses due to the tensile and compressive forces acting on the component, but also chemical stresses, such as hot-gas corrosion, for example.

[0021] When calculating the thermal stress, the temperature distribution in the component is calculated. Based on the initial temperature distribution, which is dependent on the most recent temperature distribution during the previous operational use, the instantaneous ambient temperature, and the time that has elapsed since the most recent operational use, the development of the temperature distribution is calculated over the entire operational use based on the measured operating parameters.

[0022] When calculating the mechanical stresses, the acting total load is calculated for each monitored region. The total load is composed of thermal stresses, which are induced by the momentary temperature distribution, the centrifugal stresses, which are derived from the rotational speed, and of additional stresses resulting from the gas pressure, assembly forces, etc.

[0023] Included among the service life-critical substructures of a compressor disk or turbine blisk are the blades and the disk or disk segments. Moreover, the join region between the blades and the disk may be critical, particularly in the case of friction-welded blisks, in the case of which the blades and the disk are made of different materials. In the case of blisks having a shroud, damage in the shroud may

also limit the service life.

5 [0024] The stresses acting on the individual substructures of the blisk are calculated on the basis of special algorithms which are fast enough to permit an on-board, real-time calculation. To calculate the stresses acting on the blades, five algorithms are preferably used which calculate the thermomechanical fatigue, creep, low-cycle fatigue, high-cycle fatigue and hot-gas corrosion, respectively. To calculate the stresses acting on the blade and the shroud, two algorithms are preferably used in each case which calculate creep and low-cycle fatigue. To calculate the stresses acting on the join region between the blade and the disk, two algorithms are preferably used which calculate the thermomechanical fatigue and the low-cycle fatigue.

15 [0025] The stresses, which are calculated for the individual substructures of the blisk, are subsequently assessed in terms of the relevant damage mechanism with the aid of suitable algorithms in order to estimate on the basis thereof, the added damage that occurs in the substructures during operation. This damage is accumulated with **[added to]** the already existing damage in the particular case, so that an increase in service life consumption may be calculated for each substructure relative to the total service life of the substructure.

25 [0026] The remaining service life of the particular substructure may be estimated from the difference between the potential service life and the service life consumption of the individual substructures. In this context, damage tolerances are preferably used to include a time buffer in the calculation, to ensure that the accumulated damage of the substructures is never able to reach the danger zone before the next **[scheduled]** maintenance. The remaining service life of the entire blisk is then determined by the remaining service life of the substructure having the highest service life consumption.

30

[0027] A suitable condition-dependent maintenance strategy may then be developed as a function of the remaining service lives calculated in this manner.

However, if the service-life monitoring of the blisk reveals that the damage to the blades is already quite advanced, while the service life consumption of the disk is not yet considerable, one possible maintenance strategy could be to replace the blades at the end of their remaining service life, however, to continue to use the disks following a repair or reconditioning. On the other hand, should it turn out that the service-life consumption of the two substructures has advanced to approximately the same level, replacing the complete blisk may be the more economical alternative. In the first case, following the maintenance, only the accumulated damage of the blades would be reset to zero, while the remaining substructures retained their accumulated damage, whereas, in the second case, the accumulated damage of all substructures would be reset to zero.

[0028] The result, therefore, is that the service-life monitoring according to the present invention renders possible a blisk maintenance that is better suited for meeting the requirements and is more cost-effective. Moreover, the data acquired from the service-life monitoring may also be used for other purposes, such as for further developing the engine or for adapting the engine hardware and engine software to the individual application prototype of the engine.

[0029] It is understood that the service-life monitoring according to the present invention is not only useful for aircraft engines, but also for stationary turbines, such as gas turbines, for example, that are not continuously driven at a constant operating power. Thus, other possible uses and exemplary embodiments that were not explicitly addressed may also fall under the scope of protection of the patent claims.

25

PATENT CLAIMS

1. A device for monitoring the service life of an engine or of a turbine having a compressor blisk and/or a turbine blisk, comprising:
- 5 a read-in device for inputting operating parameters measured during the course of engine or turbine operation;
- a stress calculator for calculating the momentary stresses of blisk substructures on the basis of the measured operating parameters; and
- 10 a damage estimator for estimating the accumulated damage to the individual blisk substructures caused by the momentary stresses **[the stress condition at a given instant of time]**,
- at least two of the substructures: blade (1), disk (2), and, to the extent that it is present, the join region (3) between the blade (1), disk (2) and the shroud being included among the substructures of the blisk for which the stress calculator
- 15 calculates the momentary stresses.
2. The device as recited in claim 1, at least two of the stress conditions: thermomechanical fatigue, creep, low-cycle fatigue, high-cycle fatigue and hot-gas corrosion counting among the momentary stresses which are calculated by the
- 20 stress calculator.
3. The device as recited in one of claims 1 through 2, the damage estimator using damage tolerances.
- 25 4. A method for monitoring the service life of an engine or of a turbine having a compressor blisk and/or a turbine blisk, comprising the steps of:
- measuring the operating parameters in the course of engine or turbine operation;
- calculating the momentary stresses of substructures of the blisk on the basis
- 30 of the measured operating parameters; and
- estimating the accumulated damage to the individual blisk substructures caused by the momentary stresses,

the momentary stresses of at least two of the substructures blade (1), disk (2), and, to the extent that it is present, the join region (3) between the blade (1), disk (3) and the shroud being calculated in the step of calculating the momentary stresses.

5 5. The method as recited in claim 4, at least two of the stress conditions: thermomechanical fatigue, creep, low-cycle fatigue, high-cycle fatigue and hot-gas corrosion being calculated in the step of calculating the momentary stresses.

6. The method as recited in one of claims 4 through 5, damage tolerances being
10 used in the step of estimating the accumulated damage.

7. A use of the device according to one of the claims 1 through 3 or of the method according to one of the claims 4 through 6 for developing a maintenance strategy.

15

1/1

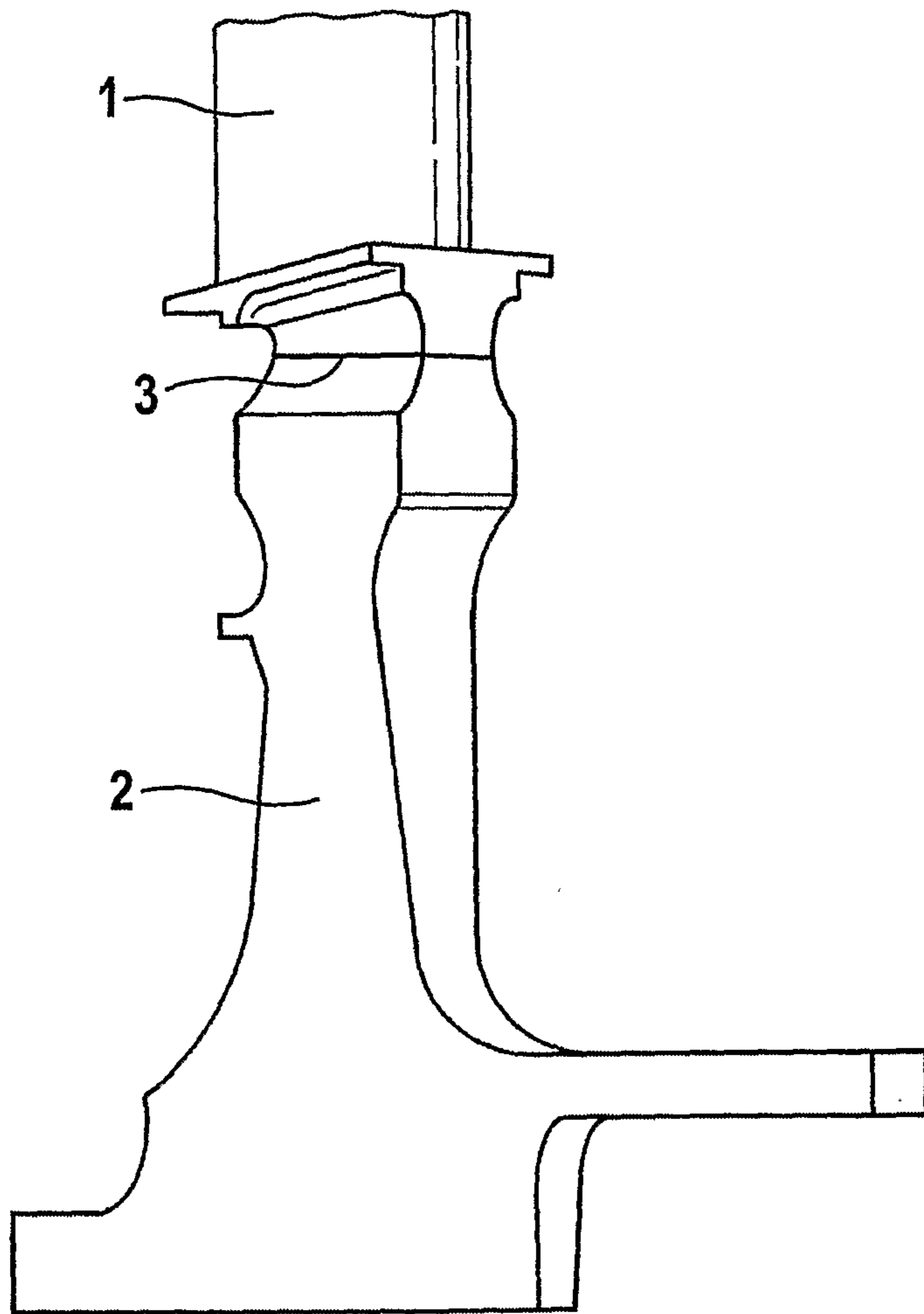

Fig. 1

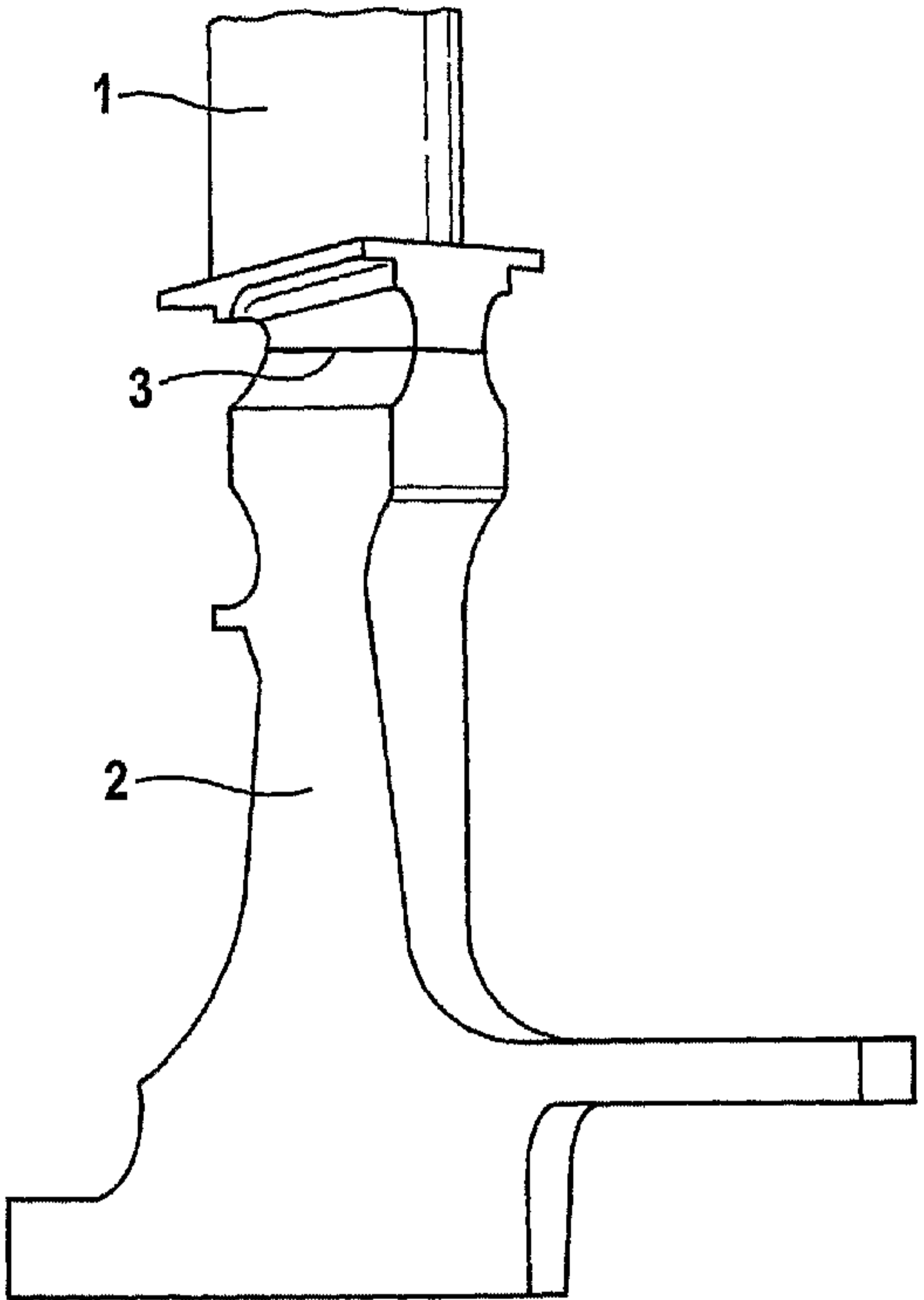

Fig. 1